

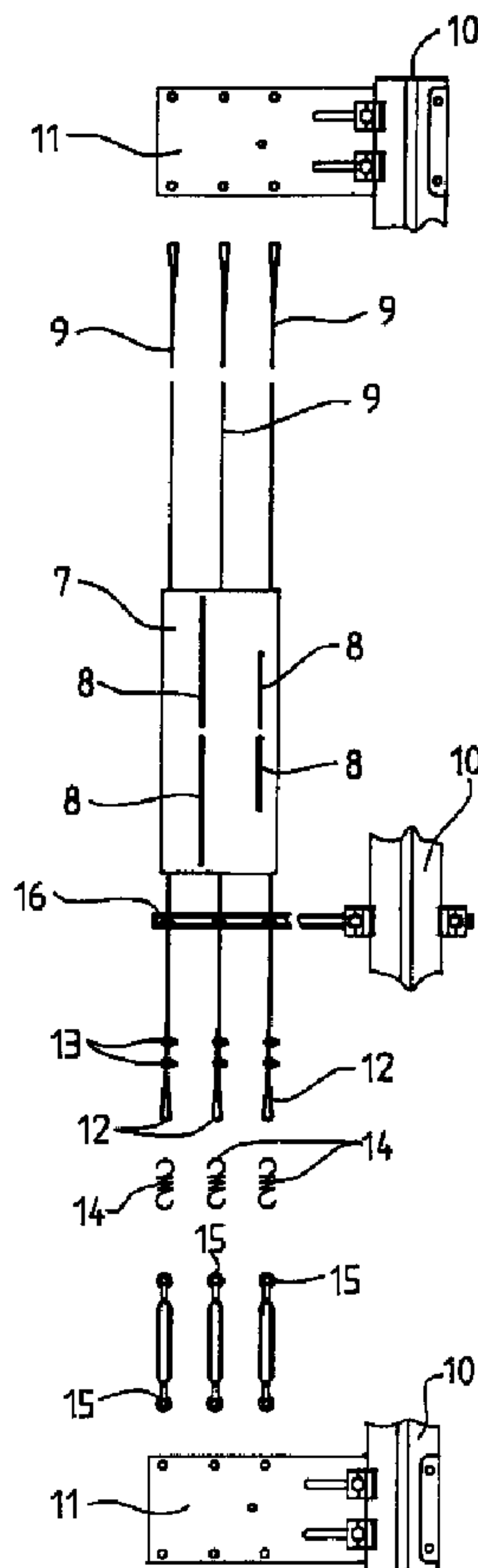

(22) Date de dépôt/Filing Date: 1999/09/14
 (41) Mise à la disp. pub./Open to Public Insp.: 2000/03/14
 (45) Date de délivrance/Issue Date: 2007/12/18
 (30) Priorité/Priority: 1998/09/14 (EP98 810910.4)

(51) Cl.Int./Int.Cl. *B66B 3/00* (2006.01),
B66B 1/50 (2006.01)
 (72) Inventeurs/Inventors:
FOLLI, STEFANO, CH;
SCHERRER, ALAIN, CH;
MILIMATTI, PAOLO, CH
 (73) Propriétaire/Owner:
INVENTIO AG, CH
 (74) Agent: RICHES, MCKENZIE & HERBERT LLP

(54) Titre : EQUIPEMENT DE FIXATION DE TRANSMETTEURS D'INFORMATION RELATIVE A UN PUIT D'ASCENSEUR
 (54) Title: FASTENING EQUIPMENT FOR SHAFT INFORMATION TRANSMITTERS OF A LIFT INSTALLATION



(57) Abrégé/Abstract:

In this fastening equipment for shaft information transmitters (4), two to three carriers (7) with shaft information transmitters (4) are arranged in different height positions at cables (9) stretched over the entire height of the shaft for each storey. A respective bracket

(57) **Abrégé(suite)/Abstract(continued):**

(11) arranged at a guide rail (10) is provided at each of the lower and upper shaft ends. A cable end is formed as cable thimble (12). The cable thimbles (12) of the upper cable ends are connected directly with the upper bracket (11). Tension springs (14), which are connected at one end each with a respective shackle (15), are connected at the cable thimbles (12) of the lower cable ends. The cable (9) can be prestressed by the shackle (15) arranged at the lower bracket (11) at one end. In the illustrated embodiment, three cables (9) are provided, a respective outer one and a middle one, wherein the middle cable (9) is slightly displaced relative to the outer cables (9) towards the rear in the depth and the outer cables (9) are slightly displaced inwardly in the width of the carrier (7). For larger lift installations, a retaining rail (16), which is arranged at the guide rail (10) and by means of which the cables (9) are held fast, is provided for each three to four storeys. The retaining rail (16) damps cable oscillations initiated manually in particular during the assembly.

Abstract:

In this fastening equipment for shaft information transmitters (4), two to three carriers (7) with shaft information transmitters (4) are arranged in different height positions at cables (9) stretched over the entire height of the shaft for each storey. A respective bracket (11) arranged at a guide rail (10) is provided at each of the lower and upper shaft ends. A cable end is formed as cable thimble (12). The cable thimbles (12) of the upper cable ends are connected directly with the upper bracket (11). Tension springs (14), which are connected at one end each with a respective shackle (15), are connected at the cable thimbles (12) of the lower cable ends. The cable (9) can be prestressed by the shackle (15) arranged at the lower bracket (11) at one end. In the illustrated embodiment, three cables (9) are provided, a respective outer one and a middle one, wherein the middle cable (9) is slightly displaced relative to the outer cables (9) towards the rear in the depth and the outer cables (9) are slightly displaced inwardly in the width of the carrier (7). For larger lift installations, a retaining rail (16), which is arranged at the guide rail (10) and by means of which the cables (9) are held fast, is provided for each three to four storeys. The retaining rail (16) damps cable oscillations initiated manually in particular during the assembly.

(Fig. 2)

Description:

Fastening equipment for shaft information transmitters of a lift installation

The invention concerns a fastening equipment for shaft information transmitters of a lift installation consisting of cables, which are stretched over the height of the shaft and at which the shaft information transmitters provided for the production of shaft information are arranged, wherein the shaft information is produced by means of the shaft information transmitters and a sensor unit arranged at a lift cage.

A lift shaft with non-magnetic cables, which are stretched over the height of the shaft and at which magnetisable segments are arranged, has become known from patent specification US 4 203 506. At least one segment is provided for each storey. Sensors for the scanning of the magnetisable segments are provided at the lift cage movable in the lift shaft. The signals of the sensors are used for the production of control signals for the lift cage.

A disadvantage of the known equipment lies in that expensive non-magnetic cables are necessary for the magnetisable segments. The segments arranged directly at the cables are moreover no longer displaceable. Furthermore, additional segments are mountable only with great effort.

Here, the invention is to provide a remedy. The invention solves the problem of avoiding the disadvantages of the known equipment and creating a fastening equipment, by means of which the shaft information transmitter is mountable without great effort and positionable accurately at any time.

In one aspect, the present invention provides fastening equipment for shaft information transmitters of a lift installation consisting of cables, which are stretched over the height of the shaft and at which the shaft information transmitters provided for the production of shaft information are arranged, wherein the shaft information is produced by means of the shaft information transmitters and a sensor unit arranged at a lift cage, wherein at least one carrier, which is arranged to be displaceable at the cables, for the carrying of at least one shaft information transmitter is provided.

1a

The advantages achieved by the invention are to be seen substantially in that great savings in the assembly time are possible. The shaft information transmitters of a lift installation with, for example, five storeys can be mounted in at most two hours. It is furthermore of advantage that all shaft information transmitters of one shaft position are displaceable at the same time without the relative position of the shaft information transmitters one to the other changing. It is furthermore advantageous that the shaft information transmitters can be preassembled at the factory and the shaft information transmitters of one shaft position can be positioned accurately relative to each other.

Then, only the entire transmitter unit need be arranged at the corresponding shaft height on location.

The invention is explained more closely in the following by reference to drawings which illustrate an embodiment and in which:

- Fig. 1 shows a fastening equipment for shaft information transmitters of a lift installation,
- Fig. 2 shows a side elevation of the fastening equipment,
- Fig. 3 shows a three-dimensional illustration of a carrier for shaft information transmitters,
- Fig. 4 shows a section along the line A-A of Fig. 3,
- Fig. 5 shows a section along the line B-B of Fig. 3,
- Fig. 6 shows a shaft information transmitter arranged at the carrier and
- Fig. 7 shows a three-dimensional illustration of the carrier arranged at cables.

A lift cage movable in a lift shaft 2 is denoted by 1 in Figs. 1 to 7. A sensor unit 3, by means of which the position of shaft information transmitters 4 arranged in the lift shaft 2 is detectable, is arranged at the lift cage 1. Each transmitter 4 is arranged at a carrier 7 with longitudinal slots 8 by means of a screw 5 and a nut 6. For each storey, two to three carriers 7 are arranged in different height positions at cables 9 stretched over the entire height of the shaft. In the embodiment, three cables 9 are shown. Only two, or more than three, cables 9 could also be provided. A respective bracket 11 arranged at a guide rail 10 is provided at each of the lower and the upper shaft end. A cable end is formed as cable thimble 12 and fixed by means of cable clamps 13. The cable thimbles 12 of the upper cable ends are connected directly with the upper bracket 11. Tension springs 14, which are connected at one end each with a respective shackle 15, engage at the cable thimbles 12 of the lower cable ends. The cable 9 can be prestressed by the shackle 15 arranged at one end at the lower bracket 11. In the illustrated embodiment, three cables 9 are

provided, a respective outer one and a middle one, wherein the middle cable 9 is displaced relative to the outer cables 9 slightly to the rear in the depth and the outer cables 9 are slightly displaced inwardly in the width of the carrier 7. For larger lift installations, a retaining rail 16, which is arranged at the guide rail 10 and by means of which the cables 9 are held fast, is provided for each three to four storeys. The retaining rails 16 damps cable installations in particular initiated manually during the assembly. Cable oscillations are hardly produced during the movement of the lift cage 1 in the lift shaft 2.

Fig. 3 shows the carrier 7 as seen from the rear side as in three-dimensional illustration. The carrier 7 consists of a carrier plate 17 with longitudinal slots 8, which are surrounded by grooves 18 at the rear, of an outer web 19 for each narrow side and a middle web 20, wherein the outer webs 19 are formed to be somewhat higher than the middle web 20. The webs 19 and 20 are connected by means of longitudinally extending ribs 21. The outer webs 19 have guide slots 22 at each corner facing a carrier plate. A respective clamping slot 23 is arranged centrally at each edge of the outer webs 19, which lies opposite the carrier plate 17, wherein the direction of one clamping slot 23 is opposite to the direction of the other clamping slot 23. Clamping slots 23 corresponding with the slots 22 and 23 of the outer webs 19 are arranged at the middle web 20. The position of the clamping slots 23 of the middle web 20 together with the position of the slots 22 and 23 of the outer webs 19 results in a cable guide, as shown in Fig. 7.

Fig. 6 shows a shaft information transmitter 4, which is arranged at the carrier plate 17 by means of the screw 5 and the nut 6 guided in the groove 18. The illustrated shaft information transmitter 4 is, for example, a magnet which for the production of shaft information changes the switching state, for example, of a magnetic switch of the sensor unit 3 when the lift cage 1 travels past. By reason of the switching state of the magnetic switch, the lift control knows the position of the lift cage 1 in the lift shaft 2 and can, for example, control the drive appropriately. Other transmitters, operating for example on the inductive or capacitive principle, with the associated sensors can also be used. The magnets 4 are mounted correctly in position on the carrier in the factory. On location, the middle cable 9 is clamped correctly in position at the middle clamping slots 23 of the carrier 7. Thereafter, the outer cables 9 are clamped in the corresponding clamping slot 23 or laid into the corresponding guide slots 24. The carrier 7 is retained firmly by the cables 9. With a certain force effort, the carrier 7 can, however, be displaced upwardly or downwardly along the cables 9.

cables 9. With a certain force effort, the carrier 7 can, however, be displaced upwardly or downwardly along the cables 9.

Fig. 7 shows the cable guide after installation of the carrier 7. The middle cable is deflected to the front by the clamping slot 23 of the middle web 20 and the outer cables 9 are slightly deflected inwardly by the clamping slots 23 of the middle web 20. The carrier 7 is stiffened and additionally fixed within the carrier 7 by the illustrated cable guide.

What is claimed is:

1. Fastening equipment for shaft information transmitters (4) of a lift installation consisting of cables (9), which are stretched over the height of the shaft and at which the shaft information transmitters (4) provided for the production of shaft information are arranged, wherein the shaft information is produced by means of the shaft information transmitters (4) and a sensor unit (3) arranged at a lift cage (1), wherein at least one carrier (7), which is arranged to be displaceable at the cables (9), for the carrying of at least one shaft information transmitter (4) is provided.
2. Fastening equipment according to claim 1, wherein the carrier (7) is arranged at the cables (9) free of extraneous fastening means.
3. Fastening equipment according to claim 1 or 2, wherein the carrier (7) comprises at least one web (19, 20), at which guide slots (22) and/or clamping slots (23) for the reception of the cables (9) are provided.
4. Fastening equipment according to claim 3, wherein the carrier (7) has at least one longitudinal slot (8) for the displaceable arrangement of at least one shaft information transmitter (4).
5. Fastening equipment according to claim 3, wherein ribs (21) extending between the webs (19, 20) are provided for stiffening the carrier (7).
6. Fastening equipment according to any one of claims 1 to 5, wherein the shaft information transmitter (4) is a magnet which for the production of shaft information changes the switching state of a magnetic switch of the sensor unit (3) on the lift cage (1) when travelling past.
7. Fastening equipment according to any one of claims 1 to 6, wherein the brackets (11) arranged at a guide rail (10) are provided for the fastening of the cable ends, wherein at least one respective shackle (15) and/or tension spring (14) is or are provided for tensioning each cable (9).

8. Fastening equipment according to claim 7, wherein a retaining rail (16), which is arranged at the guide rail (10) and by means of which the cables (9) are held fast, is provided for the avoidance of cable oscillations.

Fig. 1

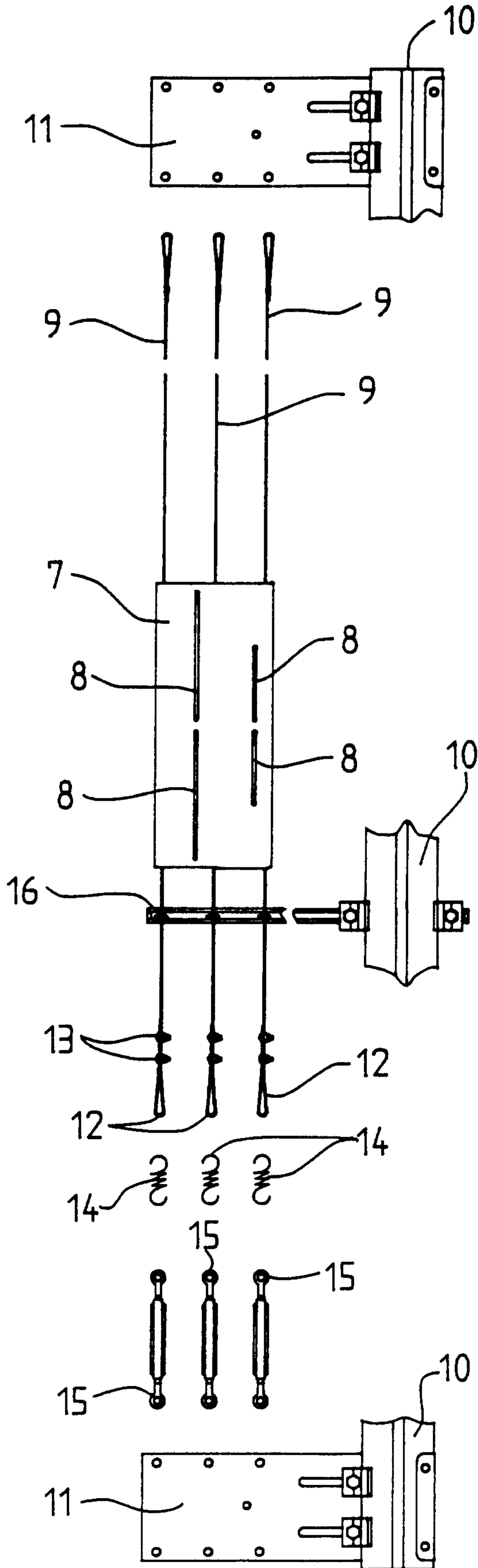

Fig. 2

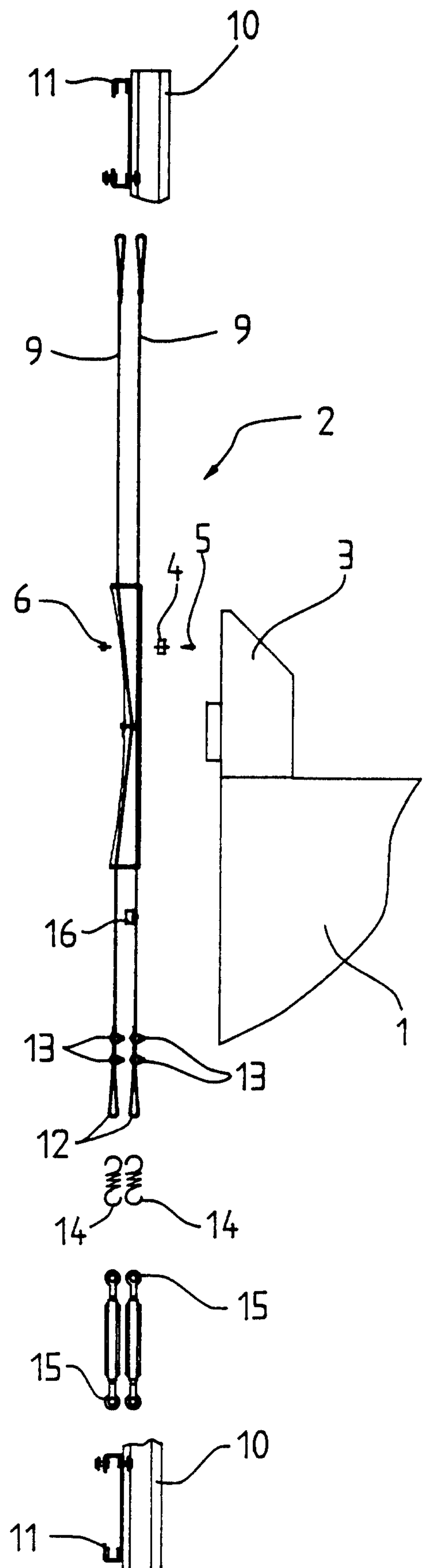

Fig. 3

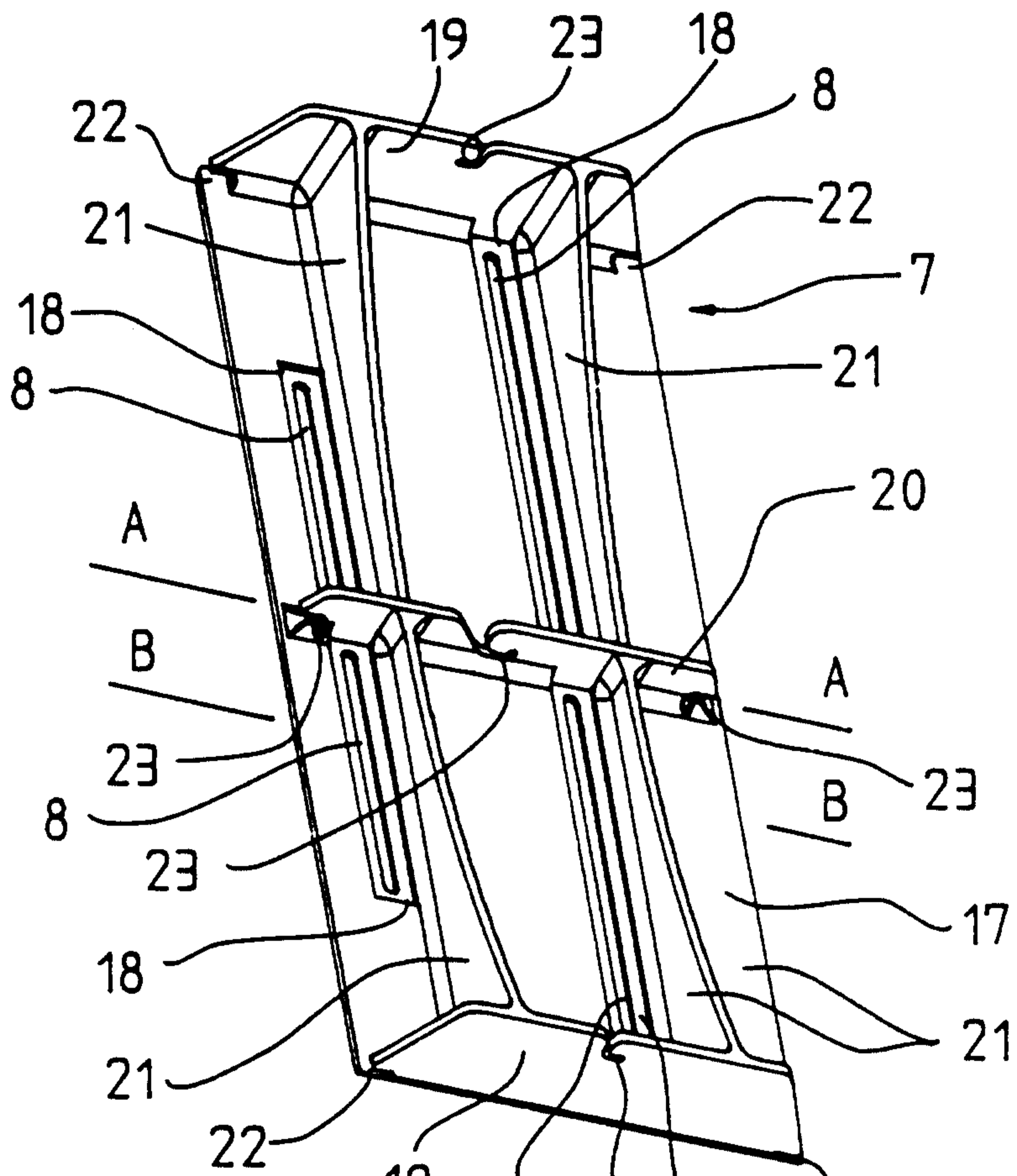

Fig. 4

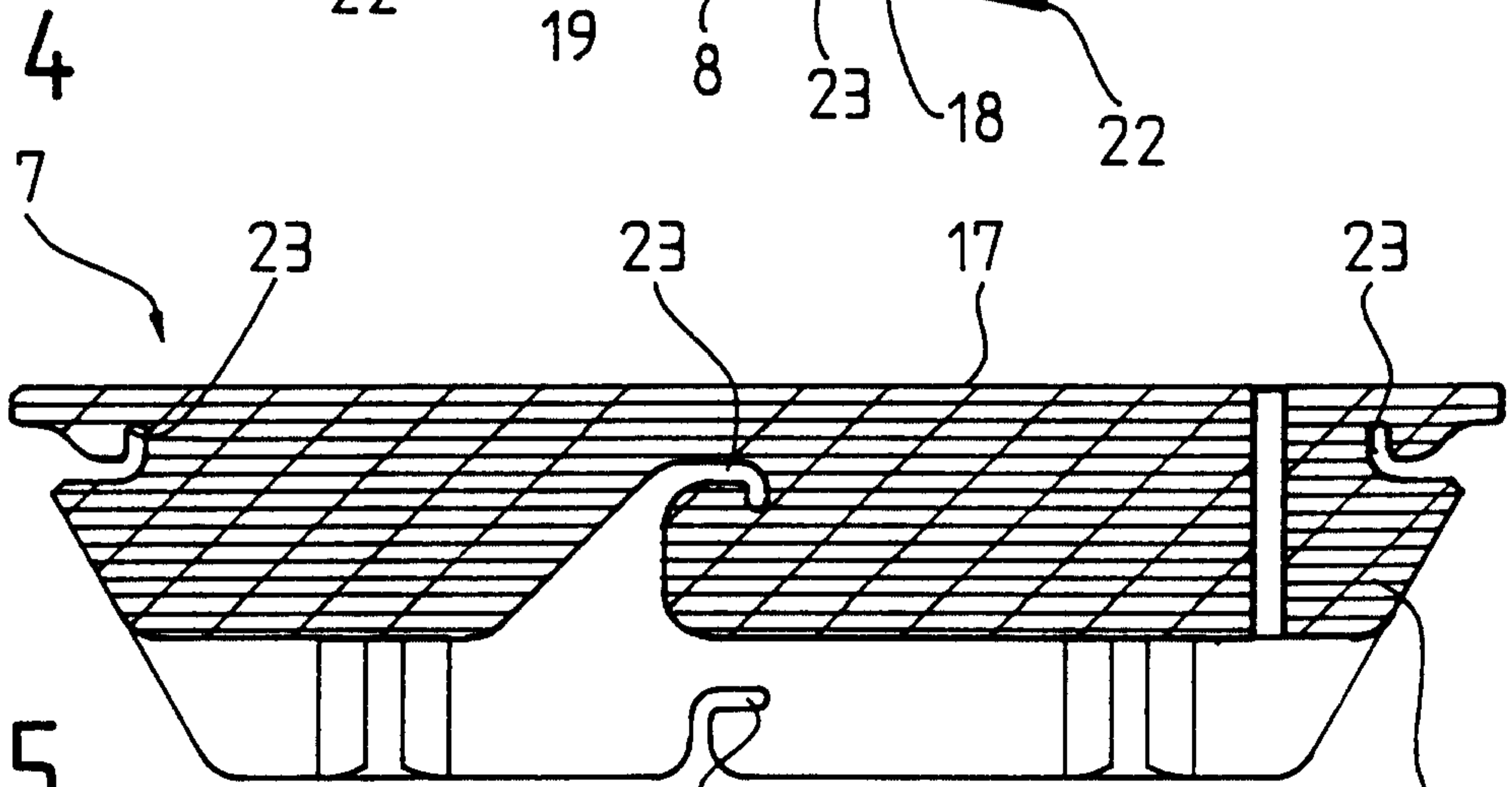

Fig. 5

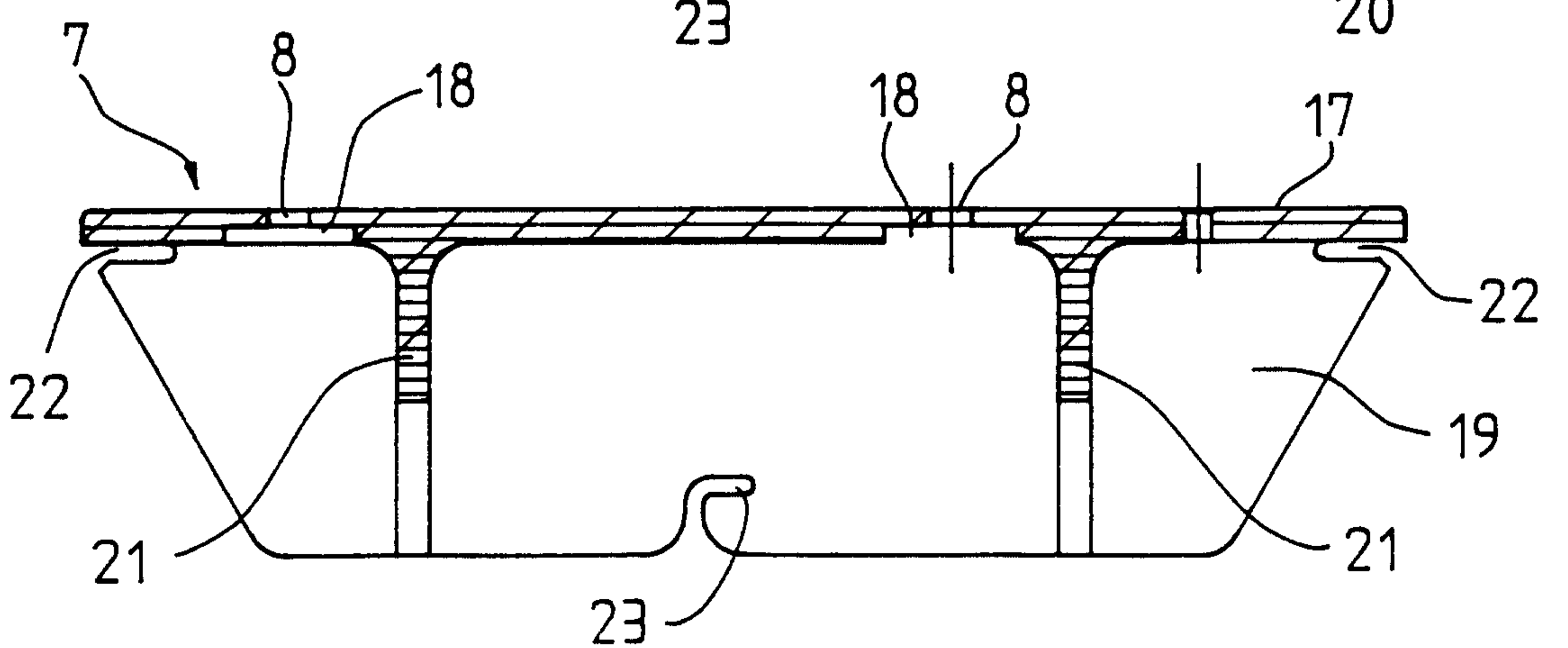

Fig. 6

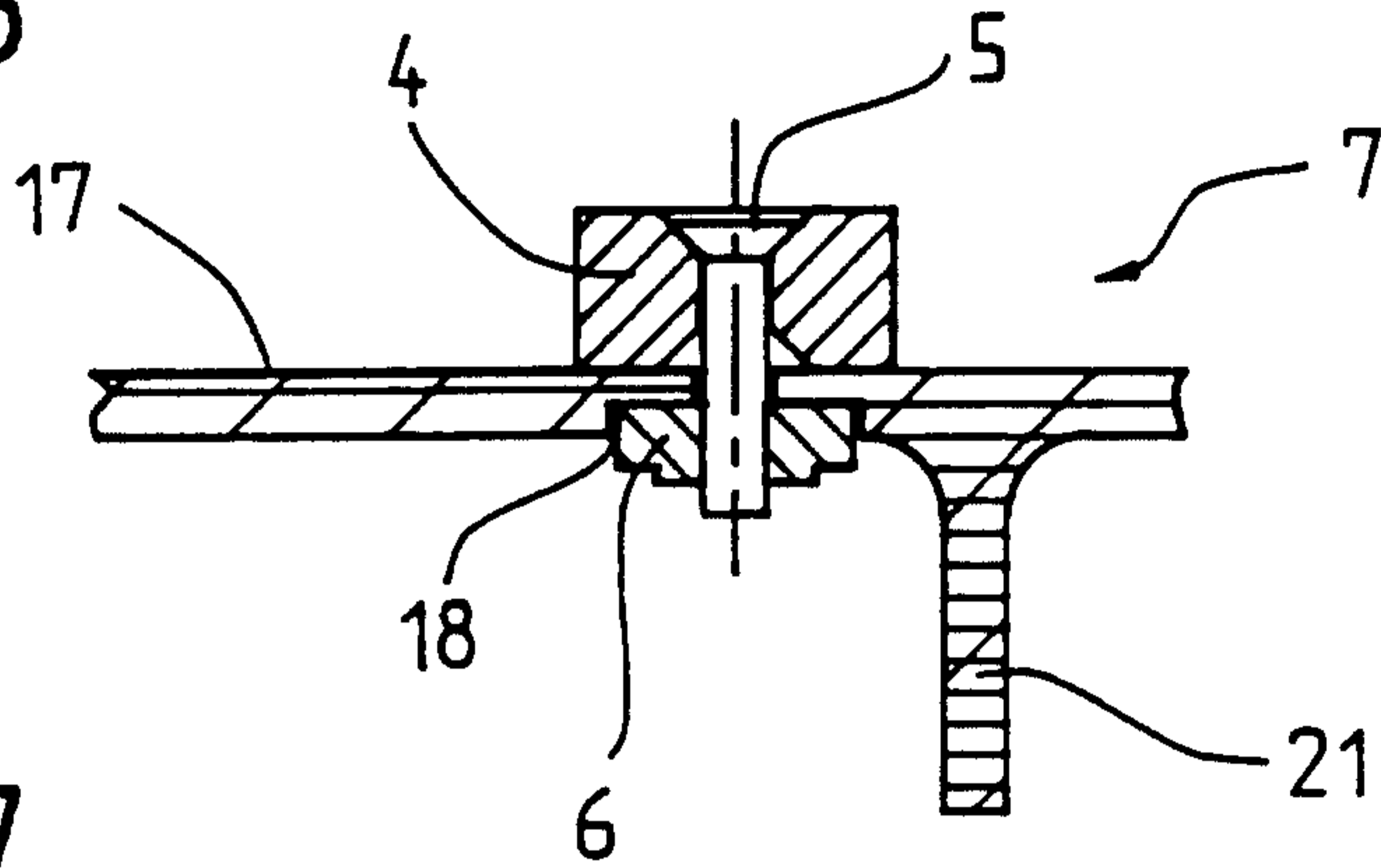

Fig. 7

