

(19) World Intellectual Property Organization
International Bureau



(43) International Publication Date
9 November 2006 (09.11.2006)

PCT

(10) International Publication Number
WO 2006/119381 A2

- (51) International Patent Classification:
B65D 73/00 (2006.01)
- (21) International Application Number:
PCT/US2006/017026
- (22) International Filing Date: 4 May 2006 (04.05.2006)
- (25) Filing Language: English
- (26) Publication Language: English
- (30) Priority Data:
11/122,686 5 May 2005 (05.05.2005) US
11/206,608 18 August 2005 (18.08.2005) US
11/225,904 14 September 2005 (14.09.2005) US
11/369,360 7 March 2006 (07.03.2006) US
- (71) Applicant (for all designated States except US): **BRAD-FORD COMPANY** [US/US]; 13500 Quincy Street, P.O. Box 1199, Holland, MI 49422-1199 (US).
- (72) Inventors; and
- (75) Inventors/Applicants (for US only): **NYEBOER, Calvin, D.** [US/US]; 3580 N. 160th Avenue, Holland,

MI 49424 (US). **FEENSTRA, Mark, J.** [US/US]; 12517 124th Avenue, Grand Haven, MI 49417 (US). **BRAD-FORD, Judson A.** [US/US]; 3400 Elderwood Avenue, Holland, MI 49424 (US). **BAZANY, Donald, J.** [US/US]; 17649 Tamarack Lane, Grand Haven, MI 49417 (US). **BUBLITZ, Timothy, A.** [US/US]; 12988 Ail Drive, Grand Haven, MI 49417 (US). **DOBRINSKI, Brian, T.** [US/US]; 5983 Sandy Way, Zeeland, MI 49464 (US).

(74) Agents: **POFFENBERGER, J., Dwight, Jr.** et al.; WOOD, HERRON & EVANS, L.L.P., 2700 Carew Tower, Cincinnati, OH 45202 (US).

(81) Designated States (unless otherwise indicated, for every kind of national protection available): AE, AG, AL, AM, AT, AU, AZ, BA, BB, BG, BR, BW, BY, BZ, CA, CH, CN, CO, CR, CU, CZ, DE, DK, DM, DZ, EC, EE, EG, ES, FI, GB, GD, GE, GH, GM, HR, HU, ID, IL, IN, IS, JP, KE, KG, KM, KN, KP, KR, KZ, LC, LK, LR, LS, LT, LU, LV, LY, MA, MD, MG, MK, MN, MW, MX, MZ, NA, NG, NI, NO, NZ, OM, PG, PH, PL, PT, RO, RU, SC, SD, SE, SG, SK, SL, SM, SY, TJ, TM, TN, TR, TT, TZ, UA, UG, US, UZ, VC, VN, YU, ZA, ZM, ZW.

[Continued on next page]

(54) Title: CONTAINER HAVING MOVABLE SUPPORT MEMBER ASSEMBLIES FOR SUPPORTING DUNNAGE

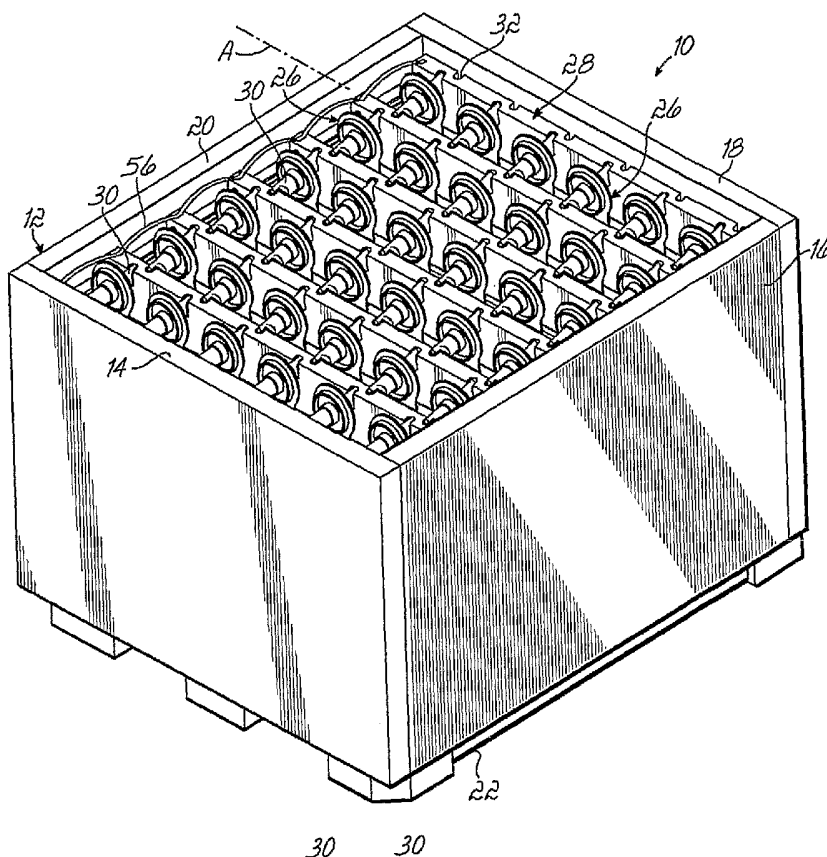

(57) Abstract: The present invention provides a container (10) for holding product (26) therein during shipment and being returned for reuse that has a body (12), tracks (52) supported by the body (12), and a plurality of support member assemblies (35), each having a pair of end members (50) engaged with and moveable along the tracks (26) and a support member (28) extending between and connected to the end members (50). The support member may be a straight tubular member (90) or a flexible cable (126) or a non-linear member (194). The support member assemblies (35) support dunnage (66) for supporting products for storage or shipment. The support members (28) may have product receptacles (32) for receiving and retaining portions of products (26). The container (10) may have multiple layers or levels of support member assemblies (35) and associated dunnage (66).

WO 2006/119381 A2



(84) **Designated States** (*unless otherwise indicated, for every kind of regional protection available*): ARIPO (BW, GH, GM, KE, LS, MW, MZ, NA, SD, SL, SZ, TZ, UG, ZM, ZW), Eurasian (AM, AZ, BY, KG, KZ, MD, RU, TJ, TM), European (AT, BE, BG, CH, CY, CZ, DE, DK, EE, ES, FI, FR, GB, GR, HU, IE, IS, IT, LT, LU, LV, MC, NL, PL, PT, RO, SE, SI, SK, TR), OAPI (BF, BJ, CF, CG, CI, CM, GA, GN, GQ, GW, ML, MR, NE, SN, TD, TG).

Published:

— *without international search report and to be republished upon receipt of that report*

For two-letter codes and other abbreviations, refer to the "Guidance Notes on Codes and Abbreviations" appearing at the beginning of each regular issue of the PCT Gazette.

CONTAINER HAVING MOVABLE SUPPORT MEMBER ASSEMBLIES FOR SUPPORTING DUNNAGE**Cross-Reference to Related Applications**

[0001] This application is a continuation-in-part of U.S. patent application Serial No. 11/225,904 filed September 14, 2005 entitled "Container Having Sliding Support Member Assemblies For Supporting Dunnage" which is a continuation-in-part of U.S. patent application Serial No. 11/122,686, filed May 5, 2005 entitled "Container Having Sliding Support Members", with each of these applications fully incorporated by reference herein.

Field of the Invention

[0002] The present invention relates to containers for use in shipping, and more particularly, to containers with movable members for supporting product.

Background of the Invention

[0003] A large number of different container structures are utilized by manufacturers to ship a variety of different products to end users, which may be, for

example, assembly plants. In the automobile industry for example, an assembly plant assembling a particular automobile might utilize a number of different parts from different manufacturers. These manufacturers ship their respective parts to the assembly plant in container structures where the parts are then removed from dunnage or support members inside the container structure and assembled into a finished automobile.

[0004] Access to the product in the containers is of particular concern. Specifically, in the automotive industry, the containers full of product are positioned on an assembly line adjacent to a work area, which is associated with a particular product to be installed on a manufactured vehicle. For example, a container full of interior door panels is usually positioned next to a particular station on an assembly line where interior door panels are installed so that a line worker may easily access the door panels inside the container. The product or part is taken directly from the container and used on the line. Some existing containers are difficult to access which makes removal of the parts therein difficult and time consuming. For example, some containers are configured so that a line worker must walk around the container to remove parts or products from opposite ends of the container. As may be appreciated, a line worker only has a certain amount of time to install a part. Any delay in access and removal of the part from the container is undesirable.

[0005] In many containers, a line worker or employee must insert or remove parts from a distal or rear part of the container. The size and/or weight of the parts or work pieces may cause stress or strain on the line worker, and more particularly on the back of the worker when inserting or removing parts from such a container. Such ergonomically unfriendly movements may cause physical trauma, pain, and other injuries that may lead to lost production time.

[0006] In some situations, in order to alleviate such stress and/or strain on his or her body, the line worker may move to the rear or opposite end of the container to remove parts from inside the container. This requires space around the container, which may not be available, depending on the physical layout of the plant or facility. The length (front to back) of certain containers may be limited because the container manufacturer needs to eliminate the need for a line worker to walk around the container to remove product from inside the container. Such containers having a reduced length reduce the number of parts or products, which may be shipped and/or stored in the container. The more containers needed to ship a predetermined number of parts, the greater the cost to the shipper.

[0007] In other containers, such as containers having multiple layers or level of parts, a line worker or employee must lean forward and bend down into the container to insert or remove a part or work piece from the bottom of the container. This movement by the line worker is ergonomically unfriendly because the line worker must lean forward and bend down into the container to insert or remove a part or work piece from the bottom of the container. This movement is necessary with many top loading containers.

[0008] Depending upon the number of times the line worker repeats this unnatural motion into the interior of the container, strain in the back, legs and arms may result. The size and/or weight of the parts or work pieces may increase the strain on the line worker. Thus, simply removing multiple parts during a work day may cause physical trauma, pain, and other injuries that may lead to lost production time.

[0009] Accordingly, there is a need for a container which prevents employees from walking around the container to insert or remove product from inside the

container.

[0010] There is further a need for a container, which prevents employees from having to perform difficult or straining repetitive reaching motions.

[0011] There is further a need for a container, which brings product into an ergonomically friendly area or zone for insertion or removal of the product.

[0012] There is further a need for a container, which may be designed for a particular application with increased product density.

Summary of the Invention

[0013] The present invention provides a container for holding product therein during shipment that has a body, tracks or retainers supported by the body, and a plurality of support members or support member assemblies that are supported by the tracks or retainers. For purposes of the present invention, the terms "support member" and "support member assembly" may be used interchangeably; either may be a unitary member or include multiple components secured together. For example, a "support member" may comprise in combination a wooden bar and a fabric cover surrounding the wooden bar or a multiple piece assembly having slidable members which move or slide inside tracks or retainers. Any number of such combinations is possible with the present invention.

[0014] Similarly, for purposes of the present invention, the terms "track" and "retainer" may be used interchangeably; either may be a unitary member or multiple components secured together. The present invention is not intended to be limited to the tracks like those illustrated and described below. For example, a "track" may comprise a groove in one or more walls of a container or a linear rod secured to one or more walls of a container. The terms "tracks" and "retainers" are intended to

include any number of objects along which support members or support member assemblies as defined or illustrated in the present document may slide or move.

[0015] The container may be collapsible such as the containers illustrated in U.S. Patent Nos. 5,725,119; 6,062,410; 6,230,916; and 6,540,096, all of which are fully incorporated by reference herein. Alternatively, the container may be non-collapsible, such as what is known in the industry as a pallet box. Furthermore, the container may have any number of wall structures including four wall structures or only two opposed wall structures.

[0016] In at least one embodiment, at least some of the support members have rollers attached to their ends. The rollers are adapted to roll in the tracks or retainers. The support members also have a plurality of product receptacles whereby products may be suspended between the support members. Typically, a portion of the product resides in or is secured in the product receptacles. These product receptacles or notches may be particularly sized and located as to mate or correspond with a portion of a particular product or a particular appendage of a product. Due to the location and/or orientation of these product receptacles, more parts or products may fit inside the container because the distance between adjacent support members may be reduced. Increased product density inside a container increases efficiency in transporting more parts and therefore reduces shipping costs.

[0017] The container may also include at least one space limiter attached to the support members to limit the distance adjacent support members may be moved or separated from each other. One acceptable space limiter is a plastic strap or like component that can flex when the distance between the support members is minimized and yet only allow the support members to move a predetermined

distance apart from each other. Another space limiter may be the fabric of the dunnage itself, as will be described in more detail below. Other materials may be used if desired.

[0018] In certain embodiments, the container further comprises stabilizers, which act on the support members to prevent their rotation. These stabilizers, which may be solid rods or hollow tubes or like components. In one embodiment of the present invention, the stabilizers pass through apertures or holes in the support members and allow the support members to freely slide along or over the stabilizers. However, the stabilizers, while allowing the support members to move along or over them, prevent the support members from rotating relative to a horizontal axis. Hence, the stabilizers insure that the support members remain in a desired generally vertical orientation at all times so that product does not fall between adjacent support members due to rotation of one or more of the support members. In alternative embodiments, the stabilizers may not pass through the support members, but rather be operatively coupled to them in any desired manner or fashion. For example, the stabilizers may pass through clips or retainers secured to the support members.

[0019] The container of the present invention is adapted so that an operator located at the front of the container may pull product to be emptied from the rear of the container forwardly to a more ergonomically friendly position after a row of products suspended by and contacting the two forward most support members, named proximal and medial support members for purposes of this document, have been unloaded or removed. Thus, a person unloading the container from the front or proximal location of the container will not have to stretch or reach to the back of the container to unload remaining product.

[0020] Similarly, a person loading the container from the front of the container need not stretch or reach to the back of the container to insert or load product into the container. The loader of the container may push the support members already loaded with rows of product rearwardly and load additional product in a more ergonomically friendly position or manner. For example, after a row of products is loaded between two support members, i.e. a distal or first and second or medial support member, these support members are pushed rearwardly to enable the loader to load an additional row of product between the medial support member and a third or proximal support member. Thus, the present invention allows product to be more efficiently and safely removed from these containers or inserted therein without unnecessary stress or strain on the unloader or loader.

[0021] Moreover, because the product receptacles are located at or near the top of the support members, products may be easily accessed. In other words, the product receptacles keep the product in an optimum location for removal by an unloader or insertion by a loader.

[0022] In an alternative embodiment of the present invention, the rollers are omitted from the support member assemblies. In this embodiment, the sides of the container body need not have tracks or retainers. The support members slide along stabilizers, which are preferably secured to opposed sides of the container body but may be located in the container in any desired manner.

[0023] In another embodiment of the present invention, preferably used in collapsible containers, support member assemblies comprise elongate flexible supports and sliders at the ends thereof. The supports, in one embodiment, are cables, but may be made of any other flexible material. The sliders are preferably made of plastic but may be made of any desired material. In this embodiment, the

sides of the container have tracks or retainers in which the sliders slide to move dunnage supported by the support members closer to the user for loading or unloading product from inside the dunnage. Each slider has at least one head located inside the interior of the track so the slider remains engaged with the track or retainer. The slider may have another head outside the track for preventing the dunnage material from entering the interior of the track or retainer.

[0024] In another embodiment of the present invention, preferably used in non-collapsible containers, support member assemblies comprise elongate tubular supports secured to sliders at the ends thereof. The tubular supports, in one embodiment, are made of metal, but may be made of any other suitable material such as plastic. The sliders are preferably made of plastic but may be made of any desired material. In this embodiment, the sides of the container have tracks or retainers in which the sliders slide to move dunnage supported by the support members closer to the user for loading or unloading product from inside the dunnage. Each slider has at least one head located inside the interior of the track so the slider remains engaged with the track or retainer. The slider may have another head outside the track for preventing the dunnage material from entering the interior of the track or retainer. The tracks may have openings therein and removable caps for covering and/or closing the openings. If one or more of the supports or support member assemblies needs to be removed, a person may remove the support member assemblies via the openings in opposed tracks.

[0025] According to another aspect of the present invention, a plurality of tracks or retainers are attached to the container at different heights. In such embodiments multiple layers or levels of product may be shipped in a single reusable and returnable container. The container may be collapsible such as the

containers illustrated in U.S. Patent Nos. 5,725,119; 6,062,410; 6,230,916; and 6,540,096 or the container may be a non-collapsible container. Multiple levels allows for maximizing the number of parts which may be shipped in a container, as well as ensuring that the product will be able to be moved to an ergonomically friendly area or zone within the container prior to its removal by an unloader and/or insertion by a loader.

[0026] For example, once an upper layer of product is removed, all the support members of the upper layer may be pushed to the rear of the container thus exposing a lower layer of product supported by a lower set of slidable support members. The lower layer of product may be removed and the lower support members continually moved toward the unloader to insure that the lower layer of product remains as close as possible to the unloader prior to it being unloaded. Similarly, once a lower layer of products is loaded or inserted into the container, another upper layer of products may be loaded in a manner which does not cause unnecessary stress or strain on the body of the individual loading the container. The container of the present invention is not limited to two layers, the container may have any number of such layers.

[0027] In another embodiment using multiple layers of dunnage, the number of parts that may be used in a container of a given size, referred to as product density, may be enhanced or increased further by using non-linear support member assemblies as compared to using linear support member assemblies. In this embodiment, the dunnage can include a plurality of pouches that extend continuously between each pair of end members of each support member assembly. Alternatively, the dunnage can comprise first and second pluralities of pouches which are spaced apart from one another, resulting in a cost savings.

[0028] According to the method of the present invention for unloading a product from a container, an unloader first removes product suspended between opposing product receptacles, a first product receptacle being located in a proximal support member and a second product receptacle being located in a medial support member. Once all the product that is suspended between the proximal and medial support members has been removed, the medial support member is rolled or moved alongside the proximal support member so that both members are located nearest to the front of the container, i.e., where the unloader is positioned. The unloader then removes the next row of product that is suspended between product receptacles in the medial member and product receptacles of a distal member. Once all the product in this row is removed, the distal member is rolled or moved to position nearest to the unloader, i.e., alongside the medial member. If the container contains additional support members, the process continues until all rows of the container have been unloaded.

[0029] Similarly, product may be easily and quickly loaded into a reusable and returnable container using the present invention. A loader first loads product so that the product is suspended between opposing product receptacles, the first product receptacle being located in a distal support member and the second product receptacle being located in a medial support member. Once a row of product has been suspended between the distal and medial support members, the distal and medial support members are rolled or moved away from the loader so that another row of products may be loaded into the receptacles of the next two support members, a proximal support member and the medial support member. The loader then inserts the next row of product so that it is suspended between product receptacles of the proximal and medial support members. Once all the product in

this row is inserted, the proximal and medial support members are rolled or moved away from the loader, i.e., to the rear of the container. If the container contains additional support members, the process continues until all support members of the container have been loaded with product being suspended therefrom.

[0030] In an alternative embodiment of the present invention that contains multiple layers of product, after the upper layer or level of products have been removed or unloaded, the unloading process continues by moving all of the upper support members, i.e., the proximal, medial, and distal members, to a position that is farthest from the unloader. A lower layer of product is thus exposed and an unloader may remove additional product that is suspended between product receptacles in a lower proximal support member and product receptacles of a lower medial support member. Once all product in this lower row is removed, the lower medial member is rolled alongside the lower proximal member so that both members are positioned nearest to the unloader. The unloader may then remove additional product suspended between product receptacles of a lower medial member and product receptacles of a lower distal member. The unloader continues the process of unloading rows of product and sliding, rolling or moving the support members towards the unloader until all product in that particular layer has been unloaded. Any number of layers of product may be unloaded in such a manner.

[0031] The method of loading the container that contains multiple layers of product comprises loading one layer at a time. The process begins by moving all of the upper support members, i.e., the proximal, medial, and distal support members for supporting the upper layer of product to a position that is farthest from the unloader so they don't interfere with loading the lower layer. A lower layer of support members is thus exposed and a loader may insert product between the support

members of the lower layer so that the product is suspended between product receptacles of these lower support members. Once all of the product receptacles in the support members of this lower layer have been fully loaded or filled, the upper support members are moved to the front of the container proximate the loader. The loader may then insert additional product between the upper support members, the additional products being suspended by product receptacles formed in the upper support members. The loader continues the process of loading rows of product and sliding, rolling or moving the support members away from the loader until all product in that particular upper layer has been loaded. Any number of layers of product may be loaded in such a manner. The methods of loading and unloading product may be used with any embodiment of the present invention including those incorporating dunnage hanging from support members.

[0032] These and other advantages of the present invention shall be made apparent from the accompanying drawings and the brief description thereof.

Brief Description of the Drawings

[0033] The accompanying drawings, which are incorporated in and constitute a part of this specification, illustrate embodiments of the invention and, together with a general description of the invention given above and the detailed description of the embodiments given below, serve to explain the principles of the invention.

[0034] FIG. 1 is a perspective view of a preferred embodiment of the reusable and returnable container of the present invention showing product being suspended by a plurality of support members;

[0035] FIG. 1A is a cross-sectional view of the reusable and returnable container shown in FIG. 1 with the product shown in dashed lines;

[0036] FIG. 2 is a perspective view of the reusable and returnable container shown in FIGS. 1 and 1A showing a product being removed from the container;

[0037] FIG. 3 is a perspective view of the reusable and returnable container shown in FIGS. 1-2 after all product has been removed between two adjacent support members and the remaining support members have been moved toward the front of the container;

[0038] FIG. 4 is a perspective view of the reusable and returnable container shown in FIGS. 1-3 after all but one row of product has been removed and the support member assemblies have been moved to the front of the container;

[0039] FIG. 5A is a partially disassembled perspective view of a portion of one of the support member assemblies shown in FIGS. 1-4;

[0040] FIG. 5B is a partially disassembled perspective view of the support member assembly shown in FIG. 5A including rollers at each end of the support member;

[0041] FIG. 5C is a perspective view of a portion of the support member assembly shown in FIGS. 5A and 5B showing the roller at the end of the support member being in a track attached to the body of the container;

[0042] FIG. 5D is a perspective view of a portion of an alternative support member assembly showing a different type of roller at the end of the support member, the roller being in a track attached to the body of the container;

[0043] FIG. 6 is a cross-sectional view of an alternative embodiment of a reusable and returnable container having multiple layers of product;

[0044] FIG. 7 is a perspective view of another embodiment of the reusable and returnable container having multiple layers of product;

[0045] FIG. 8 is a perspective view of another embodiment of the reusable

and returnable container having no rollers;

[0046] FIG. 9 is a perspective view of a collapsible reusable and returnable container showing dunnage suspended by a plurality of slidable support member assemblies;

[0047] FIG. 10 is an enlarged perspective view of the encircled area 10 of FIG. 9;

[0048] FIG. 10A is an enlarged perspective view of an alternative slider for use in a container;

[0049] FIG. 11 is a perspective view of the reusable and returnable of FIG. 9 being collapsed;

[0050] FIG. 12 is a perspective view of the reusable and returnable of FIG. 9 fully collapsed;

[0051] FIG. 13 is a perspective view of another embodiment of a collapsible reusable and returnable container showing multiple layers of dunnage suspended by a plurality of support member assemblies;

[0052] FIG. 13A is a perspective view of another embodiment of a collapsible reusable and returnable container showing dunnage suspended by a plurality of support member assemblies;

[0053] FIG. 14 is a perspective view of a non-collapsible container showing multiple layers of dunnage suspended by a plurality of support member assemblies having tubular supports;

[0054] FIG. 15 is an enlarged view of the encircled area 15 of FIG. 14;

[0055] FIG. 15A is a view taken along the line 15A-15A of FIG. 15;

[0056] FIG. 16 is an enlarged view of the encircled area 16 of FIG. 14;

[0057] FIG. 17 is a perspective view of another embodiment of a collapsible,

reusable and returnable container showing dunnage suspended by a plurality of support member assemblies;

[0058] FIG. 18 is a perspective view of another embodiment of a reusable and returnable container showing dunnage suspended by a plurality of support member assemblies;

[0059] FIG. 19 is a perspective view of the container shown in FIG. 18 with two of the container walls partially removed to illustrate the multiple layers of support member assemblies and associated dunnage;

[0060] FIG. 20 is an exploded perspective view illustrating one support member assembly and one layer of dunnage of the container shown in FIGS. 18 and 19;

[0061] FIG. 21 is a perspective view illustrating a plurality of non-linear support member assemblies and associated dunnage, of one layer of the container shown in FIGS. 18-20;

[0062] FIG. 22 is a side elevational view, partially in cross-section, further illustrating the container shown in FIGS. 18 and 19;

[0063] FIG. 23 is a cross-sectional view similar to FIG. 22, but illustrating linear support members and associated dunnage of another embodiment, showing the increased product density that is achieved using non-linear support member assemblies compared to linear support member assemblies in certain applications;

[0064] FIG. 24 is a side elevational view, partially in cross-section, illustrating the container shown in FIGS. 18 and 19 fully loaded with three layers of product;

[0065] FIG. 25 is a view similar to FIG. 24 but with the upper layer of product unloaded and the support member assemblies and associated dunnage pushed rearward in the container to provide access to the middle layer of product;

[0066] FIG. 26 is a view similar to FIGS. 24 and 25, but with the upper and middle layers of product removed and the support member assemblies and associated dunnage of these layers pushed rearward in the container to provide access to the bottom layer of product;

[0067] FIG. 27 is a view similar to FIGS. 24-26, but with the product of all three layers unloaded from the container;

[0068] FIG. 28 is a perspective view illustrating another embodiment of dunnage and non-linear support member assemblies; and

[0069] FIG. 29 is an enlarged fragmentary view, partially in cross-section, of one of the support member assemblies shown in FIG. 28.

Detailed Description of the Invention

[0070] Referring to FIG. 1, there is illustrated a reusable and returnable container 10 according to one embodiment of the present invention. The reusable and returnable container 10, as shown, comprises a body 12 having a front wall 14, a side wall 16, a rear wall 18 and another side wall 20, all extending upwardly from a base 22. Although one type of container is illustrated, the present invention may be used with any type or configuration of box or container. For example, the present invention may be used in a container in which one or more of the walls of the container is hinged for the container to be more easily erected and/or compacted for storage. The present invention may also be used in a rack type of container which has four corner posts extending upwardly from a base. A cover (not shown) may also be included to enclose the container 10 and further protect and secure product 26 during shipment.

[0071] Products 26 are suspended by and supported by a plurality of support

members 28. Although one configuration of support member 28 is illustrated, the present invention may be used with any type or configuration of support member. A portion or appendage 30 of the product 26 is specifically received in and/or secured in a product receptacle 32 in one support member 28 and another portion or appendage 30 of the same product 26 is located in a product receptacle 32 of an adjacent support member 28. See FIG. 2. These product receptacles or notches 32 are particularly machined or sized and located to receive, mate, and/or hold the portion or appendages 30 of the product 26. The product receptacles furthermore are located and sized so that a specific number of products may fit snugly inside the container 10 without moving or shifting during shipment. Although one configuration of product 26 is illustrated and described, the present invention may be used to store and ship other configurations of products not shown or described. Similarly, depending on the configuration of the product, the product receptacles or notches formed in the support members may be shaped or configured differently than those shown and described.

[0072] As shown in FIGS. 1A, 5A, 5B and 5C, a support member assembly 35 includes a divider 34 attached to the bottom 36 of the support member 28 and suspended therefrom. As shown in FIG. 5A, the divider 34 may be mounted to the lower end 36 of the support member 28 by being inserted into a longitudinally extending groove 38 formed in the support member 28 and secured therein with a plurality of fasteners 40 such as screws, rivets, nails, or the like. An adhesive, such as glue, may also be used to help secure the divider 34 to the support member 28, if desired. Any other suitable means of securing the divider 34 to the support member 28 may be used as desired. The dividers 34 prevent adjacent products 26 from contacting one another and being dented or otherwise damaged.

[0073] As also shown in FIG. 5A, tubes 42 are inserted in holes 43 formed in opposed ends 44, 46 of the support member 28 to further complete the support member assembly 35. As shown in FIG. 5B, these hollow tubes 42 are used as receptacles for rotatably receiving the axles 48 of the rollers 50. As shown in FIG. 5C, rollers 50 are adapted to roll or move in channels or tracks 52 attached to the interior surfaces 54 of the side walls 20, 16 of the container 10. FIG. 5C illustrates one roller 50 at end 44 of the support member 28 rotatably received in a track 54 secured to side wall 20. A roller 50 at the other end 46 of the support member 28 is likewise supported in a track 52 which is attached to side wall 16 of the container 10. Although one configuration of track 52 and roller 50 is shown and described, other types of rollers and tracks may be used if desired such as the one illustrated in FIG. 5D.

[0074] According to another aspect of the present invention, the reusable and returnable container 10 may also have at least one space limiter 56 which, as shown in FIGS. 1, 2 and 3, limits the distance the support members 28 may be moved away from one another due to the fact that each space limiter 56 is secured to each support member 28. Typically, the length or distance of the space limiter 56 between locations where the space limiter 56 is secured to the support members 28 will be fixed to prevent the support members 28 from moving farther apart than necessary for the insertion of product 26 between adjacent support members 28. The space limiter 56 may be secured to the upper surfaces 31 of the support members 28 in any suitable fashion including but not limited to gluing, fastening, etc. Of course, when the support members 28 are moved or rolled to a position adjacent to one another, i.e. in contact, as shown in FIG. 4, the flexibility of the space limiters 56 allows for such movement. The space limiter 56, as shown, is preferably comprised

of a plastic strap, but may be made of any other suitable material.

[0075] The embodiment of the container 10 shown in FIG. 1A also has a pair of stabilizers 58. Each stabilizer 58 passes through an aperture or opening 60 in each of the support members 28. The stabilizers 58 are positioned within the apertures 60 of the support members 28 so that the support members 28 may freely slide back and forth relative to the stabilizers 58. See FIG. 5A. The stabilizers 58 may or may not be attached to the walls of the container 10. The stabilizers 58 prevent the support members 28 from rotating relative to a horizontal axis A. See FIG. 1. If one or more of the support members 28 were to rotate the distance between adjacent product receptacles 32 could decrease due to such rotation, thereby allowing product 26 to become dislodged from the support members 28 and fall between adjacent support members 28 inside the container 10. In the embodiment shown, each stabilizer 58 comprises a rod or a tube, or the like. However, it may be any other mechanism which prevents or inhibits rotation of the support members 28.

[0076] An alternative embodiment of container 10a having a front wall 14a, a side wall (not shown), a rear wall 18a and another side wall (not shown), all extending upwardly from a base 22a is shown in FIG. 6. This container 10a has multiple layers of product suspended from support members 28a', 28a" having product receptacles (not shown), the support members 28a', 28a" being supported by sets of parallel tracks 52a', 52a" as described above. In this embodiment, a lower layer 70 of support members 28a' are adapted to move from back to front inside the interior of the container 10a in a manner described above. Lower stabilizers 58a' pass through holes in the support members 28a' as described above. Dividers 34a' are secured to and extend downwardly from the support

members 28a' as described above. Lower space limiters 56a' limit the distance the support members 28a' may separate from each other. A lower layer 72 of products 26a' are supported from the lower support members 28a' in a manner described hereinabove.

[0077] An upper layer 74 of support members 28a" are adapted to move from back to front inside the interior of the container 10a in a manner described above. Upper stabilizers 58a" pass through holes in the support members 28a" as described above. Dividers 34a" are secured to and extend downwardly from the support members 28a" as described above. Lower space limiters 56a" limit the distance the support members 28a" may separate from each other. An upper layer 76 of products 26a" are supported from the upper support members 28a" in a manner described hereinabove.

[0078] In any of the embodiments of the present invention, at least one wall of the container may be configured so as to allow an upper portion thereof to open outwardly, thereby furthering access to the products therein. Such an adaptation may be particularly helpful in gaining access to products in embodiments having multiple layers of product. Additionally, if desired, a portion of any of the walls of the container may be omitted or collapsible.

[0079] FIG. 7 shows an alternative embodiment of container 10b having a front wall 14b, a side wall 16b, a rear wall 18b and another side wall 20b, all extending upwardly from a base 22b. This container 10b, like container 10a shown in FIG. 6, has multiple layers of support members 28b which are supported by sets of parallel tracks 52b. In this embodiment, the support members 28b preferably lack product receptacles, but may have them if desired or necessary. Product (not shown) is located in hanging pouches 66 secured to the support members 28b

rather than suspended from the support members in the manner described above. The hanging pouches may assume other shapes or configurations if desired and may be suspended from the support members in any desired manner.

[0080] In this embodiment, a lower layer 78 of support members 28b' are adapted to move from back to front inside the interior of the container 10b in a manner described above. Lower stabilizers 58b' pass through holes 80 in the support members 28b' as described above. Lower space limiters 56b' limit the distance the lower support members 28b' may separate from each other. A lower layer 82 of products (not shown) are supported from the pouches 66 extending downwardly from the lower support members 28b'.

[0081] Referring to FIG. 7, an upper layer 84 of support members 28b" are adapted to move from back to front inside the interior of the container 10b in a manner described above. Upper stabilizers 58b" pass through holes 80 in the support members 28b" as described above. Upper space limiters 56b" limit the distance the support members 28b" may separate from each other. An upper layer of products (not shown) are supported from the pouches 66 extending downwardly from the upper support members 28b". Although pouches are shown, other forms of known dunnage may be used in accordance with any of the embodiments of the present invention.

[0082] FIG. 5D shows another alternative embodiment of the present invention in which each support member 90 has a pair of opposed end members or rollers 92 (only one being shown) secured at opposed ends of a support 91. The end members 92 are preferably made of injection molded plastic, but may be made of any suitable material. A pouch 94, like pouch 66 shown in FIG. 7, is supported by two adjacent support members 90. The fabric of the pouch 94 is sewn or otherwise

secured together to make a pocket 95 in which is located the support 91 of the support member 90.

[0083] As seen in FIG. 5D, tracks 96 are secured to opposed side walls 98 of the body 100 of the container 102. Each track 96 has an upper wall 104, a lower wall 106 joined to the upper wall 104 by a side wall 108 and a lip 110 extending downwardly from the upper wall 104 and another lip 110 extending upwardly from the lower wall 106 defining an interior 109 of the track 96. Each end member 92 of each support member 90 is adapted to engage and move along one of the tracks 96. Each end member 92 has a first or inside portion 112 and a second or outside portion 114 with a groove 116 therebetween. The end members 92 preferably rotate along the length or width of the tracks 96; however, the end members 92 may slide rather than rotate along the tracks 96. The outside portion 114 of the end member 92 preferably rotates inside the interior 109 of the track 96 and the inside portion 112 rotates outside of the interior 109 of the track 96, the groove 116 of the end portion 92 contacting the lips 110 of the track 96.

[0084] Although the particular track and roller arrangement or configuration illustrated in FIG. 5D is described above with respect to a hanging pouch embodiment, like the one shown in FIG. 7, it may be used in any embodiment of the present invention including the embodiment illustrated in FIG. 1.

[0085] FIG. 8 shows another alternative embodiment of container 10c having a body 12c including a front wall 14c, a side wall 16c, a rear wall 18b and another side wall 20c, all extending upwardly from a base 22c. This container 10c, like container 10 shown in FIG. 1, has a single layer of support members 28c which are supported by stabilizers 58c and slidable thereon. In this embodiment, the support members 28c lack rollers or their equivalent because they are not necessary.

Product 26c is suspended from product receptacles 32c formed in the support members 28c. Space limiters 56c limit the distance the support members 28c may separate from each other in the manner described above.

[0086] Although the embodiment shown in FIG. 8 has a single layer or level of support member assemblies, this embodiment of the present invention in which the support member assemblies lack rollers may be used in a multi-level container such as the containers shown in FIGS. 6 and 7. In such embodiments, one or more levels of support member assemblies may slide on stabilizers as shown in FIG. 6 without any rollers or tracks.

[0087] Operationally, the method of unloading product from the container 10 comprises the steps of removing a first row of products 26, as shown in FIG. 2, suspended between a first or proximal support member 80 (see FIGS. 3 and 4) and a second or medial support member 82. The second support member 82 is then moved or rolled alongside the first support member 80 so that the first and second support members 80, 82, as shown in FIG. 3, are positioned nearest to the unloader (not shown). The unloader may then remove a second row of products 26 suspended between the product receptacles of the second support member 82 and the product receptacles of a third or distal support member 84. This process continues until all product has been removed from the container 10 and all of the support members 28 are pulled forwardly and resting against one another proximate the front wall 14 of the container 10. As shown in FIG. 4, to remove the last or rearmost row of products, the operator need only reach a limited distance over the container or into the container.

[0088] In an embodiment where the container has multiple layers of product, as shown in FIGS. 6 and 7, when all product is removed from the upper layers, the

upper support members may then be moved to a position farthest from the unloader exposing a lower layer of products suspended or supported, at least in part, by support member assemblies, whereby the process of removing product and moving a new row of product closer to the unloader is repeated.

[0089] FIGS. 9, 10, 11 and 12 illustrate a collapsible reusable and returnable container 10d according to another embodiment of the present invention. The reusable and returnable container 10d, as shown, comprises a body 12d having a front wall 14d, a side wall 16d, a rear wall 18d and another side wall 20d, all extending upwardly from a base 22d. The walls 14d, 16d, 18d and 20d of container 10d are hinged to the bottom 22d of the container 10d to be more easily erected and/or compacted for storage. See FIGS. 11 and 12. Although one type of collapsible container is illustrated, the present invention may be used with other types or configurations of collapsible containers. This embodiment of the present invention may also be used in a rack type of container which has corner posts extending upwardly from a base. See FIG. 13A. The term "wall" for purposes of this document is not intended to be limited to a solid wall. For example, each wall may comprise two vertical posts joined together in any desired manner. A cover (not shown) may also be included to enclose the container 10d and further protect and secure product (not shown) during shipment. If desired one or more walls may be partially or entirely omitted, for example in a horizontal dispensing container.

[0090] Tracks 52d are secured to opposed side walls 16d, 20d of the body 12d of the container 10d in any desired manner. As best illustrated in FIG. 10, each track 52d has an upper wall 104d, a lower wall 106d joined to upper wall 104d by a side wall 108d and lips 110d extending downwardly from the upper wall 104d and upwardly from the lower wall 106d, thereby defining an interior 109d of the track 52d.

[0091] Dunnage 120 in the form of a plurality of pouches 90d are suspended by and supported by a plurality of support member assemblies 122. Although the dunnage 120 shown comprises pouches, the dunnage may assume other shapes or configurations. A pouch 90d shown in FIG. 9, is supported by two adjacent support member assemblies 122. The fabric of the pouch 90d is sewn or otherwise secured together along a seam 123 to make a pocket 125 in which is located a flexible support 126 of the support member assembly 122. See FIG. 10.

[0092] As shown in FIG. 10, a support member assembly 122 includes a pair of sliders 124 and a flexible support 126 extending therebetween. The sliders 124 are preferably made of injection molded plastic, such as nylon, but may be made of any other material. The flexible support 126 is preferably a cable but may be made of nylon or other suitable material. As shown in FIG. 10, the ends of the flexible support 126 are tied or otherwise secured to the sliders 124.

[0093] As shown in FIG. 10, each slider 124 preferably has a first portion 128 having an X-shaped cross-sectional configuration and a second portion 130 having a circular cross-sectional configuration. Although one configuration of slider 124 is illustrated, any type or configuration of slider may be used with the present invention. In this embodiment, each slider 124 has a pair of heads 132, 134 at the end of the slider 124. Head 132 is furthest from the first portion 128 of the slider 124 and head 134 is spaced inwardly from head 132. The heads 132, 134 are spaced from one another to define a groove 136 therebetween which receives and retains the lips 110d of the track 52d. As shown in FIG. 10, head 132 is located inside the interior 109d of track 52d and head 134 is located outside the interior 109d of track 52d. Head 132 keeps the slider 124 engaged with the track 52d while head 134 keeps the material of pouch 90d out of the interior 109d of the track 52d, thereby ensuring

that the sliders 124 may move smoothly along the tracks 52d. Although one configuration of support member assembly 122 is illustrated, the present invention may be used with any type or configuration of support member assembly for supporting dunnage so the dunnage may slide or move inside the container.

[0094] FIG. 10A shows another alternative embodiment of the present invention in which each slider 124' has only one head 132', rather than a pair of heads (as shown in FIG. 10). Head 132' remains inside the interior 109' of the track 52d' and keeps the slider 124' engaged with the track 52d'.

[0095] FIG. 11 illustrates the container 10d of FIG. 9 being collapsed or partially collapsed. More specifically, wall 16d is disengaged from erected walls 14d and 18d and swung inwardly towards the interior of the container 10d. As shown in FIG. 12, after walls 16d, 20d are collapsed, walls 14d, 18d are collapsed. Due to the nature of the dunnage 120 and support member assemblies 122, the dunnage is collapsed and shipped with the container.

[0096] FIG. 13 illustrates a collapsible container 10e, like the collapsible container 10d shown in FIG. 9. The collapsible container 10e collapses in the same manner as the container 10d of FIG. 9. See FIGS. 11 and 12. The reusable and returnable container 10e, as shown, comprises a body 12e having a front wall 14e, a side wall 16e (only a portion being shown), a rear wall 18d and another side wall 20e, all extending upwardly from a base 22e and hingedly secured to the base 22e for purposes of collapsing the walls. The front wall 14e has a drop down door 137 hinged to the remainder of the front wall 14e with hinges 139. The door 137 is movable between an erect position (not shown) and a open position shown in FIG. 13 to allow easy access to the interior of the container 10e. Any of the walls or sides of any of the containers described or shown herein may have lockable doors like

door 137 shown in FIG. 13 of any desired size or configuration. Such access doors are particularly useful in a multi-layer or multi-level container for access to the lower layer or level of dunnage and/or product.

[0097] Although one type of collapsible container is illustrated, this embodiment may be used with other types or configurations of collapsible containers. For example, this embodiment may also be used in a rack type of container having corner posts extending upwardly from a base. See FIG. 13A. A cover (not shown) may also be included to enclose the container 10e and further protect and secure product (not shown) during shipment. If desired, in this embodiment, one or more walls may be partially or wholly omitted, for example in a horizontal dispensing container.

[0098] Container 10e has multiple layers of dunnage 120e in the form of pouches 90e for supporting product (not shown) suspended therefrom. Although each layer or level of dunnage 120e is shown as being multiple pouches 90e formed or created from one piece of material draped or laying over and secured to the support member assemblies 122 as shown in FIG. 10 and described above, it is within the present invention that each pouch be made from its own piece of material in which case the pouches would not be interconnected. However, one advantage of having multiple pouches 90e being formed of one piece of material and secured to support member assemblies 122e as shown in FIG. 13 is that an operator (not shown) may pull an entire layer or group of pouches 90e by pulling only one support member assembly 122e or more towards the operator. Thus, the fabric of the pouches 90e acts like the space limiter 56 shown in FIG. 1 and described above. This is true for any of the embodiments described in this document.

[0099] Multiple tracks 52e are secured to opposed walls 16e, 20e in any

desired manner at different spaced vertical heights, levels or locations. Although two layers of dunnage are illustrated in FIG. 13, any number of layers of tracks may be incorporated into collapsible container 10e. In this embodiment, a lower layer 136 of support members 122e supporting pouches 90e are adapted to move from back to front inside the interior of the container 10e in a manner described above. Similarly, an upper layer 138 of support members 122e supporting pouches 90e are adapted to move from back to front inside the interior of the container 10e in a manner described above.

[00100] FIG. 13A illustrates a collapsible container 10f which collapses in a similar manner as the other containers illustrated and described above. The reusable and returnable container 10f, as shown, comprises a body 12f having a opposed side walls or structures 14f extending upwardly from a base 16f and hingedly or pivotally secured to the base 16f for purposes of collapsing the walls 14f. Each side structure 14f comprises a pair of corner posts 17f joined together with structural members 18f and/or rails or tracks 20f. Although FIG. 13A illustrates only one set of rails or tracks 20f, multiple layers of tracks may be incorporated into such a container to create a multi-level container like those shown and described above.

[00101] Container 10f has a single layer of dunnage 120f in the form of pouches 90f for supporting product (not shown) suspended therefrom. Multiple tracks 20f are secured to corner posts 16f in any desired manner at any desired vertical height, level or location. Although one layer of dunnage is illustrated in FIG. 13A, any number of layers of tracks may be incorporated into collapsible container 10f. In this embodiment, support member assemblies 122f supporting pouches 90f are adapted to move from back to front inside the interior of the container 10f in a manner described above. If desired, in this embodiment, depending on the

dunnage, the container may be a horizontal dispensing container, rather than a vertical dispensing container.

[00102] FIGS. 14, 15, 15A and 16 illustrate a container 10g, similar to the collapsible container 10e shown in FIG. 13. The container 10g, as shown, comprises a body 12g having a front wall 14g, a side wall 16g (only a portion being shown), a rear wall 18g and another side wall 20g, all extending upwardly from a base 22g. Although one type of non-collapsible container is illustrated, this embodiment may be used with other types or configurations of containers. For example, this embodiment may also be used in a rack type of container having corner posts extending upwardly from a base. A cover (not shown) may also be included to enclose the container 10g and further protect and secure product (not shown) during shipment. If desired, in this embodiment, one or more walls may be partially or wholly omitted, for example in a horizontal dispensing container.

[00103] Container 10g has multiple layers of dunnage 120g in the form of pouches 90g for supporting product (not shown) suspended therefrom. Multiple tracks 52g are secured to opposed walls 16g, 20g in any desired manner at different spaced vertical heights, levels or locations. Like tracks 52d shown in FIG. 10, each track 52g has an upper wall 104g, a lower wall 106g joined to upper wall 104g by a side wall 108g and lips 110g extending downwardly from the upper wall 104g and upwardly from the lower wall 106g, thereby defining an interior 109g of the track 52g. Other configurations or shapes of track may be used if desired.

[00104] Although two layers of dunnage are illustrated in FIG. 14, any number of layers of tracks may be incorporated into container 10g to create multiple levels or layers of dunnage. In this embodiment, a lower layer 140 of support member assemblies 122g supporting pouches 90g are adapted to move from back to front

inside the interior of the container 10g in a manner described above. Similarly, an upper layer 142 of support member assemblies 122g supporting pouches 90g are adapted to move from back to front inside the interior of the container 10g in a manner described above.

[00105] As best shown in FIGS. 15 and 15A, a support member assembly 122g includes a pair of sliders 124g like sliders 124 shown in FIG. 10 and described above. The support member assembly 122g further comprises a tubular support 144 having a hollow interior 146 extending therebetween. The tubular support 144 is preferably made of metal, but may be made of other suitable material such as plastic. As shown in FIG. 15, each end of tubular support 144 fits over at least one portion 128g of a slider 124g. An end surface 148 of tubular support 144 abuts head 134g of slider 124g.

[00106] As best shown in FIG. 15A, some of the support member assemblies 122g' used in the container 10g include a pair of sliders 124g' as shown in FIG. 15A which are slightly different than sliders 124g described above. The only difference between sliders 124g and 124g' is that sliders 124g' have a groove 150 formed in a portion 130g' therein. See FIG. 15A. Support member assemblies 122g' further include a tubular support 144' having a hollow interior 146' extending therebetween. The tubular support 144' is preferably made of metal, but may be made of other suitable material such as plastic. As shown in FIG. 15A, each end of tubular support 144' fits over at least one portion 128g' of a slider 124g'. An end surface 148' of tubular support 144' abuts head 134g' of slider 124g'. As shown in FIG. 15A, tubular support 144' has holes 152 therethrough which receive fasteners 154. Although fasteners 154 are shown as screws, they may be any other type of fasteners. The fasteners 154 prevent separation of the tubular support 144' from the sliders 124g'

while allowing some movement therebetween as the fastener 154 moves within the groove 150 formed in the sliders 124g'.

[00107] As one skilled in the art will appreciate, the increased number of parts of support member assemblies 122g' increases the cost and time of assembly of support member assemblies 122g' when compared to support member assemblies 122g. Consequently, only a few support member assemblies used inside a container like container 10g need have the tubular support 144' secured to the sliders 124g' like in support member assemblies 122g'. The remaining support member assemblies may be like support member assembly 122g, with no fasteners 154. For example, FIG. 14 illustrates three of the nine support member assemblies having fasteners 154 like in support member assembly 122g' shown in FIG. 15A.

[00108] FIG. 16 illustrates another support member assembly 122g', exactly like the one shown in FIG. 15A used to support one of the pouches 90g. However, FIG. 16 illustrates another innovative feature or aspect of the present invention. Rail 52g has an opening or cutout 156 formed therein. A pair of holes 158 are formed in the upper wall 104g of rail 52g which are sized and threaded to receive fasteners 158. Although fasteners 158 are illustrated to be screws, they may be any other desirable fastener. A cap 160 is removably secured to the rail 52g to cover the opening or cutout 156 formed in an upper portion of rail 52g. As best seen in FIG. 16, cap 160 has a generally inverted U-shaped cross-sectional configuration including a top portion 162 and side portions 164 extending downwardly from the top portion 162. Holes 166 are formed through the top portion 162 of the cap 160 and sized to receive fasteners 158 as shown in FIG. 16. The fasteners 158 are adapted to pass through the holes 166 in the cap 160 and into the holes 159 in the upper wall 104g of the rail 54g.

[00109] When one of the sliders 124g, 124g' or any part of support member assemblies 122g, 122g' are damaged or need to be replaced for any reason, one may remove cap 160 after loosening fasteners 158, thereby exposing the opening or cutout 156 of rail 52g. The support member assemblies 122g, 122g' are then removed as necessary to fix the damaged part or parts. The opening in the rail 52g may be at any desired location and may or may have an associated cap or cover. This is true with any of the rails described in this document.

[00110] FIG. 17 illustrates a collapsible container 10h comprising a body 12h having a front wall 14h, opposed side walls 16h and a rear wall 18h, all extending upwardly from a base 22h. Although one type of collapsible container is illustrated in FIG. 17, this embodiment may be used with other types or configurations of containers. For example, this embodiment may also be used in a rack type of container having corner posts extending upwardly from a base as shown in FIG. 13A. A cover (not shown) may also be included to enclose the container 10h and further protect and secure product (not shown) during shipment. If desired, in this embodiment, one or more walls may be partially or wholly omitted, for example in a horizontal dispensing container.

[00111] As shown in FIG. 17, the front wall 14h has a drop down door 160 hinged to the remainder of the front wall 14h with hinges 164. The door 160 is movable between an erect position (not shown) and a open position shown in FIG. 17 to allow easy access to the interior of the container 10h. Any of the walls or sides of the container may have lockable doors like hinged door 160 shown in FIG. 17 of any desired size or configuration. This is true for any of the containers or embodiments described herein.

[00112] Container 10h has multiple layers of dunnage 120h in the form of

pouches 90h for supporting product (not shown) suspended therefrom. Multiple tracks 52h are secured to opposed walls 16h in any desired manner at different spaced vertical heights, levels or locations. Each track 52h may be like track 52g shown in FIG. 16 or track 52f shown in FIG. 15. Other configurations or shapes of track may be used if desired.

[00113] Although three layers of dunnage are illustrated in FIG. 17, any number of layers of tracks may be incorporated into container 10h to create multiple levels or layers of dunnage. In this embodiment, a lower layer 162 of support member assemblies 122h supporting pouches 90h are adapted to move from back to front inside the interior of the container 10h in a manner described above. Similarly, a middle layer 166 and an upper layer 170 of support member assemblies 122h supporting pouches 90h are adapted to move from back to front inside the interior of the container 10h in a manner described above.

[00114] FIGS. 18-22 and 24-27 illustrate a non-collapsible container 10i according to another aspect of the present invention. The container 10i, as shown, comprises a body 12i having a front wall 14i, side walls 16i and a rear wall 18i, all secured to a base 22i and extending upwardly above base 22i. Although one type of container is illustrated, this embodiment may be used with other types or configurations of containers. For example, this embodiment may also be used in a rack type of container having corner posts extending upwardly from a base. A cover (not shown) may also be included to enclose the container 10i and further protect and secure product (not shown) during shipment. If desired, one or more walls may be partially or wholly omitted, for example in a horizontal dispensing container. For purposes of this document, the term "wall" may include any structure and is not intended to be limited to solid walls made of any particular material.

[00115] As shown in FIGS. 19, 22 and 24-27, container 10i has multiple layers of dunnage 120i in the form of pouches 90i for supporting product 26i (shown in FIGS. 22 and 24-27) suspended therefrom. The dunnage 120i of each layer is supported by a plurality of support member assemblies 190, discussed subsequently in detail. For purposes of this document, the terms support member assembly and support may be used interchangeably. Both are intended to be supports for different forms of dunnage in any manner known to those skilled in the art.

[00116] Multiple tracks 52i are secured to opposed walls 16i in any desired manner at different spaced vertical heights, levels or locations. Like tracks 52d shown in FIG. 10 and tracks 52f shown in FIG. 16, tracks 52i comprise an upper wall 104i, a lower wall 106i joined to upper wall 104i by a side wall 108i and lips 110i extending downwardly from the upper wall 104i and upwardly from the lower wall 106i, thereby defining an interior 109i of the track 52i, as shown in FIG. 19. If desired, one or more tracks 52i may have an opening or cutout with or without a removable cap like track 52g shown in FIG. 16. The openings in the tracks 52d aid in removing the support member assemblies 190 and may be located at any desired location. Other configurations or shapes of track may be used.

[00117] Although three layers of tracks 52i are illustrated in FIGS. 19, 22 and 24-27, any desired number of layers of tracks may be incorporated into container 10i at desired locations. Any number of the tracks may be utilized to create multiple levels or layers of dunnage 120i. In this embodiment, a lower layer 180 of support member assemblies 190 supporting dunnage in the form of a plurality of pouches 90i are adapted to move from back to front inside the interior of the container 10i in a manner described above. Similarly, a middle layer 182 and an upper layer 184 of support member assemblies 190 each supporting a layer of dunnage in the form of

pouches 90i are adapted to move from back to front inside the interior of the container 10i in a manner described above. See FIGS. 20 and 22.

[00118] As shown in FIGS. 18, 19, 22 and 24-27, the support member assemblies 190 are disposed within the body 12i of container 10i. Referring now to FIGS. 20 and 21, the features of support member assemblies 190 and pouches 90i are discussed in greater detail. The support member assemblies 190 of this embodiment are generally non-linear as shown in FIGS. 20 and 21.

[00119] As best illustrated in FIG. 20, each support member assembly 190 includes a pair of end members 192 and a non-linear support member 194 extending between the end members 192. Also contemplated within the present invention is a one-piece support in which the support has end portions engaged with the tracks.

[00120] Support member 194 is generally or substantially U-shaped as shown in FIGS. 20 and 21. Each of the end members 192 includes a head 196 adapted to move in the interior 109i of one of the tracks 52i and a guard 197 spaced apart inwardly from head 196 that prevents dunnage 120i from entering tracks 52i. Each end member 192 also includes a portion 198 adapted to be received and/or retained in a tubular end portion 200 of a support member 194. Each end member 192 may be a unitary member or made of several parts. For example, head 196, guard 197 and portion 198 can be integrally formed from injection molded plastic like the sliders 124 shown in FIG. 10. Each end member 192 may be made of any suitable materials and may be made with or without the use of injection molding. The non-linear support member 194 is preferably made of aluminum, but may be made of other suitable material such as plastic. The non-linear support member 194 usually has a hollow interior but may be partially or wholly solid.

[00121] A portion of each end member 192 may be rotatable relative to the support member 194 and rotatable within one of the tracks 52i. The end members 192 may alternatively be slidable or non-rotatable within tracks 52i.

[00122] As best shown in FIG. 20, the non-linear support member 194 comprises outer portions 200, sloping portions 202 and a bottom portion 206. Each sloping portion 202 slopes downwardly away from one of the outer portions 200 to the bottom portion 206. The two outer portions 200 may or may not be co-linear with one another. For purposes of this document, non-linear means any configuration which is not straight. Therefore, not only is the support member 194 non-linear, but each support member assembly 190 is non-linear as it extends across the interior of the container.

[00123] As shown in FIG. 20, each layer of dunnage 120i includes a plurality of pouches 90i. The dunnage layer 120i may be made of one piece of material, such as a woven or non-woven fabric, or may be made of multiple pieces of material sewn or otherwise secured to one another. Dunnage layer 120i also includes a plurality of pockets 95i for receiving and retaining the support members 194. Each of the support members 194 resides inside one of the pockets 95i as shown in FIG. 20, with a plurality of support member assemblies 190 supporting the dunnage layer 120i. FIG. 21 illustrates a layer of dunnage 120i after a plurality of support members 194 have been inserted in pockets 95i of dunnage layer 120i and non-linear support members 194 have been incorporated into support member assemblies 190.

[00124] The use of container 10i, incorporating non-linear support members 194, results in an increase in product density as compared to containers of like size incorporating linear support members, where product density is the number of product units per volume of container, as is known in the art. Greater product

density results in lower shipping costs and is therefore advantageous. The resultant increase in product density using container 10i is illustrated by a comparison of FIGS. 22 and 23.

[00125] FIG. 22 illustrates container 10i with three layers of dunnage 120i supported by corresponding support member assemblies 190. FIG. 23 illustrates a container 10j, which is the same size as container 10i illustrated in FIG. 22. For purposes of illustration, containers 10i and 10j have the same vertical height, i.e. sides 16i of container 10i have the same vertical height as sides 16j of container 10j, and containers 10i and 10j have the same inside volume.

[00126] The vertical distance between vertically adjacent non-linear support members 194 of container 10i is illustrated as dimension 210 in FIGS. 22 and 23. Likewise, the vertical distance between vertically adjacent linear support members 122j of container 10j is illustrated as dimension 212 in FIG. 23. As shown in FIG. 23, dimension 210 is substantially smaller or less than dimension 212. Such spacing permits three layers of support members 194 and associated dunnage 120i for product 26i in container 10i compared to two layers of dunnage 120j of product 26i in container 10j, for the same size containers 10i and 10j. Even though the internal volume of containers 10i and 10j are the same, the number of layers of dunnage 120i and consequently product which may be packed inside container 10i is greater than the number of layers of dunnage 120j and product which may be packed inside container 10j. This increased product density is due, at least in part, to the non-linear configuration of the support members 194. Consequently, use of support member assemblies 190 having irregular or non-linear shaped support members 194 in container 10i results in a fifty percent increase in product density compared to the product density of container 10j using the linear support members

122j, resulting in significantly lower shipping costs. This same advantage can be achieved with other product having configurations different from the configuration of product 26i.

[00127] One method of unloading product 26i from container 10i is illustrated in FIGS. 24-27. FIG. 24 illustrates three layers 180, 182 and 184 of dunnage 120i, each layer containing product 26i, and corresponding movable support member assemblies 190. The unloading process is initiated by removing product 26i residing in the upper layer or row 184 of dunnage 120i. More particularly, a single product 26i, residing in a pouch 90i supported by a proximal support member assembly 190a and a second, adjacent support member assembly 190b is removed. The second support member assembly 190b is then moved or rolled forward alongside the first support member assembly 190a so that the first and second support member assemblies 190a, 190b, are positioned nearest to the unloader (not shown) at the front of the container 10i. The unloader may then remove a second product 26i suspended in a pouch 90i supported by the second support member assembly 190b and a third support member assembly 190c. This process continues until all of the product 26i has been removed from the upper layer 184 of dunnage 120i and all of the support member assemblies 190 of layer 184 have been pulled forwardly and rest against one another proximate the front wall 14i of container 10i. To remove the last or rearmost row of product 26i, the unloader only needs to reach a limited distance over or into the container 10i. This is ergonomically beneficial to the employee or unloader. The support member assemblies 190 and associated dunnage 120i of the upper layer 184 are then pushed rearwardly as shown in FIG. 25, thereby exposing product 26i suspended by the middle layer 182 of dunnage 120i.

[00128] The previously discussed process is then repeated to unload the product suspended by the middle layer 182 of dunnage 120i. FIG. 26 illustrates container 10i after all of the product 26i has been unloaded from the middle layer 182 of dunnage 120i and the dunnage 120i and associated support member assemblies 190 have been moved rearward in container 10i.

[00129] The process is repeated again to unload product 26i from the bottom layer 180 of dunnage 120i. FIG. 27 illustrates container 10i after all product 26i has been removed from layer 180 and the dunnage 120i and associated support member assemblies 190 have been moved rearward within container 10i.

[00130] FIGS. 28 and 29 illustrate support member assemblies 220 and dunnage 240 according to another embodiment of the present invention. Dunnage 240 is supported by a plurality of the support member assemblies 220. Support member assemblies 220 and dunnage 240 may be elements of a variety of containers including containers having a single layer of dunnage or multiple layers of dunnage. For example, support member assemblies 220 and dunnage 240 may be used in lieu of support member assemblies 190 and dunnage 120i, respectively, of container 10i. Each non-linear support member assembly 220 includes a non-linear support member 194, also included in support member assemblies 190 of container 10i and discussed previously with reference to FIGS. 18-27. Support member assemblies 220 include a pair of end members 222 secured to the non-linear support member 194 as previously discussed.

[00131] As shown in FIG. 28, dunnage 240 includes a plurality of innerconnected or integral pouches 242 and a second plurality of innerconnected or integral pouches 246 that are laterally spaced apart from the first plurality of pouches 242. Each pouch 242, 246 includes a pocket 248 adapted to received and

retain a portion of a support member 194. A portion of each non-linear support member 194 and a portion of each of the corresponding end members 222 reside within one of the pockets 248, with the support member assemblies 220 supporting the pouches. Each pouch 242 has an inner end 245 and an opposed outer end 247. Similarly, each pouch 246 has an inner end 245 and an opposed outer end 247. The inner ends 245 of the pouches 242 are adjacent to and spaced apart from the inner ends 245 of the pouches 246. Each pouch 242, 246 is attached to a respective one of the support member assemblies 220 as subsequently discussed.

[00132] As also shown in FIG. 28, each of the pouches 242, 246 joins one of the end portions 200, one of the sloping portions 202 and part of the bottom portion 206 of two non-linear support members 194. Since no pouches are suspended from a substantial portion of the span of the bottom portion 206 of support member 194, significantly less material is required to make dunnage 240 as compared to that required to make dunnage 120i of container 10i discussed previously, resulting in a cost savings. A product (like product 26i) may be supported by one of the pouches 242 and a corresponding and aligned pouch 246.

[00133] As shown in FIG. 29, each end member 222 includes a head 250 adapted to move within the interior of one of the tracks of the corresponding container, such as the interior 109i of one of the tracks 52i of container 10i shown in FIGS. 18, 19, 22 and 24-27. Each end member 222 also includes a guard 252 spaced apart inwardly from head 250 that prevents dunnage 240 from entering the tracks of the corresponding container, such as tracks 52i. Each end member 222 also includes a portion 254 sized to fit in a tubular end portion 200 of support member 194. Each end member 222 may be made as a one-piece, unitary construction of injection molded plastic. However, head 250, guard 252 and portion

254 may be made of other suitable materials and may be made without the use of injection molding. As discussed previously with respect to container 10i, the non-linear support member 194 is preferably made of aluminum, but may be made of other suitable material. Also, as discussed previously, the non-linear support member 194 usually has a hollow interior but may be partially or wholly solid.

[00134] If desired, end members 222 may be identical to sliders 124 shown in FIG. 10 or may be slightly different in configuration.

[00135] The dunnage 240 is attached to the support member assemblies 220 as follows. Dunnage 240 includes a plurality of openings in the form of grommets 256, each grommet 256 being secured to one of the pouches 242, 246. A conventional fastener, such as screw 258 passes through an aperture 257 formed in grommet 256, then through an aperture 260 formed in the end portion 200 of support member 194 and into groove 262 formed in end member 222, thereby securing pouch 244 to support member 194. Each of the pouches 244 of the first 242 and second 246 pluralities of pouches 244 are attached to the support members 194 of support member assemblies 220 in this manner. However, other methods or forms of attachment may be used.

[00136] The fasteners 258 prevent separation of the end members 222 from the corresponding support members 194 while allowing some linear movement therebetween as the fasteners 258 move within the corresponding grooves 262. However, the end members 222 can not rotate relative to the corresponding support member 194. Accordingly, the heads 250 of end members 222 slide within the tracks of the corresponding container, such as tracks 52i of container 10i.

[00137] In any of the embodiments described herein, the tracks or retainers need not be located on the side walls or structures. They may be located on the

front and rear walls or structures, as long as two opposed walls or side structures support them. Similarly rails or retainers having openings covered with removable caps as shown in FIG. 16 may be used in any of the embodiments described herein.

[00138] While various embodiments of the present invention have been illustrated and described in considerable detail, it is not the intention of the applicant to restrict or in any way limit the scope of the claims to such detail. Additional advantages and modifications will readily appear to those skilled in the art. The invention in its broader aspect is, therefore, not limited to the specific details, representative system, apparatus, and method, and illustrative example shown and described. Accordingly, departures may be made from such details without departing from the spirit or scope of the applicant's general inventive concept.

What is claimed is:

1. A container for holding product therein during shipment, the container comprising:

a body having a bottom and at least two walls;

tracks supported by the body;

a plurality of support member assemblies inside the body, each of said support member assemblies comprising a pair of end members engaged with and moveable along said tracks and a support member having extending between and connected to said end members, at least some of said support members having product receptacles, wherein products may be suspended between support members, portions of the products residing in the product receptacles.

2. The container of claim 1 further comprising dunnage supported by said support member assemblies.

3. The container of claim 1 further comprising stabilizers acting on the support members to prevent rotation of the support members.

4. The container of claim 1 further comprising at least one space limiter attached to the support members for limiting the distance two of the support members may be spaced from each other.

5. The container of claim 1 wherein the end members of the support member assemblies are rollers.

6. The container of claim 1 wherein the tracks are at different vertical heights.
7. A container for holding product therein during shipment, the container comprising:
 - a body;
 - tracks supported by the body;
 - multiple levels of support member assemblies, each of said support member assemblies comprising a pair of end members engaged with and moveable along said tracks and a support member extending between said end members, wherein at least some of said support members have product receptacles for receiving portions of products suspended between two of the support members.
8. The container of claim 7 further comprising dunnage supported by the support member assemblies.
9. The container of claim 8 wherein the dunnage is pouches.
10. The container of claim 7 further comprising stabilizers for prevention rotation of the support members.
11. The container of claim 7 further comprising at least one space limiter attached to two support members for limiting the distance the two support members may be spaced from each other.

12. A container for holding product therein during shipment, the container comprising:

a body;

a plurality of tracks supported by the body at different heights;

a plurality of support member assemblies, each of said support member assemblies comprising a pair of end members engaged with and moveable along said tracks and a support member extending between and connected to said end members;

and

dunnage supported by said support member assemblies.

13. The container of claim 12 wherein at least some of said support members are straight.

14. The container of claim 12 wherein the dunnage comprises pouches.

15. The container of claim 12, wherein the dunnage comprises a single piece of material.

16. The container of claim 12 wherein at least some of the tracks have openings for removal of at least some of the support member assemblies.

17. The container of claim 12 wherein at least some of support members are tubular.

18. The container of claim 12 wherein at least some of support members are non-linear.
19. The container of claim 12 wherein said dunnage is attached to at least some of support member assemblies.
20. The container of claim 12 wherein each of said end members includes a head engaged with and moveable along one of said tracks.
21. The container of claim 20 wherein each of said end members further comprises a guard spaced from said head for preventing said dunnage from entering said tracks.
22. The container of claim 12 wherein the container is collapsible.
23. A container for holding product therein during shipment, the container comprising:
a body;
multiple levels of support member assemblies, each of said support member assemblies comprising a pair of end portions engaged with and moveable along said tracks; and
dunnage supported by said support member assemblies.

24. The container of claim 23 wherein at least some of said support member assemblies have product receptacles for receiving portions of products suspended between two of the support member assemblies.
25. A method of unloading product from a container comprising the steps of:
removing product suspended by a proximal support member and a medial support member;
moving the medial support member alongside the proximal support member;
and
removing additional product suspended by the medial support member and a distal support member.
26. The method of claim 25 further comprising moving the distal support member towards the medial support member.
27. The method of claim 25 further comprising the steps of:
moving the proximal, medial and distal support members to a position farthest from the unloader, thereby exposing a lower layer of suspended products;
removing more product suspended between a lower proximal support member and a lower medial support member;
moving the lower medial support member alongside the lower proximal support member; and
removing more product suspended between the lower medial support member and a lower distal support member.

28. A method of loading product into a container comprising the steps of:
inserting products between a distal support member and a medial support member so the products are suspended therefrom;
moving the medial and distal support members having products suspended therefrom away from a loader; and
inserting additional products between the medial support member and a proximal support member so the additional products are suspended therebetween.
29. The method of claim 28 further comprising moving the proximal support member and medial support members having products suspended therefrom away from the loader so additional products may be loaded in the container.
30. A container for holding product therein during shipment, the container comprising:
a body having a bottom and at least two side walls coupled to the bottom, the side walls being moveable between an erected position and a collapsed position;
tracks secured to the side walls of the container;
support member assemblies inside the container, each of said support member assemblies comprising a pair of end members engaged with and moveable along said tracks and a support member extending between said end members; and
dunnage supported by the support member assemblies, said dunnage being collapsed when said side walls are in said collapsed position and erected when said side walls are in said erected position.

31. The container of claim 30 wherein the container has multiple levels of tracks and support member assemblies.
32. The container of claim 30 wherein said end members are plastic sliders.
33. The container of claim 30 wherein said dunnage comprises pouches.
34. The container of claim 30 wherein at least some of the tracks have openings for removal of at least some of the support member assemblies.
35. A container for holding product therein during shipment, the container comprising:
- a collapsible body;
 - tracks supported by the body at different heights;
 - support member assemblies engaged with the tracks, each of the support member assemblies comprising a pair of end members engaged with and moveable along said tracks and a flexible support member extending between said end members; and
 - dunnage supported by the support member assemblies.
36. The container of claim 35 wherein said dunnage comprises pouches.
37. The container of claim 35 wherein the end members are plastic sliders.

38. The container of claim 35 wherein at least some of the tracks have openings for removal of at least some of the support member assemblies.
39. A container for holding product therein during shipment, the container comprising:
- a body;
 - tracks supported by the body at different heights;
 - support member assemblies engaged with the tracks, each of the support member assemblies comprising a pair of end members engaged with and moveable along said tracks and a tubular support member extending between said end members; and
 - dunnage supported by the support member assemblies.
40. The container of claim 39 wherein said dunnage comprises pouches.
41. The container of claim 39 wherein the container has multiple levels of support member assemblies and dunnage.
42. The container of claim 39 wherein at least some of the tracks have openings for removal of at least some of the support member assemblies.
43. The container of claim 42 wherein said openings are covered with removable caps.

44. A container for holding product therein during shipment, the container comprising:

a body having a bottom and at least two walls;

a plurality of tracks supported by the body;

a plurality of support member assemblies inside the body, each of said support member assemblies comprising a pair of end members engaged with and moveable along said tracks and a non-linear support member extending between and connected to said end members;

dunnage supported by said support member assemblies.

45. The container of claim 44 wherein said support member includes a pair of outer portions, first and second sloping portions and a bottom portion, said first sloping portion sloping downwardly away from one of said outer portions to said bottom portion, said second sloping portion sloping downwardly away from the other of said outer portions to said bottom portion.

46. The container of claim 44 wherein each of said end members comprises a head and a guard spaced from said head for preventing said dunnage from entering said tracks.

47. The container of claim 44 wherein said dunnage comprises a plurality of pouches.

48. The container of claim 47 wherein said pouches are attached to said support member assemblies with fasteners.

49. The container of claim 44 wherein said dunnage comprises a single piece of material.
50. The container of claim 44 wherein said support members are at least partially hollow.
51. The container of claim 44 wherein some of tracks have openings therein.
52. A container for holding product therein during shipment, the container comprising:
a body having at least two walls extending upwardly from a bottom;
a plurality of tracks on opposed walls of said container;
a plurality of non-linear support member assemblies, each of said support member assemblies being slidable along said tracks; and
dunnage supported by said support member assemblies.
53. The container of claim 52 wherein portions of said support member assemblies are at least partially hollow.
54. The container of claim 52 wherein each of said support member assemblies includes end members and a non-linear support member extending between said end members.
55. The container of claim 52 wherein said dunnage comprises pouches.

56. The container of claim 52 wherein dunnage comprises multiple pouches supported by a pair of said support member assemblies.
57. The container of claim 55 wherein at least some of said pouches are secured to said support member assemblies.
58. The container of claim 55 wherein said pouches are spaced from each other.
59. The container of claim 52 wherein said dunnage is secured to said support member assemblies with fasteners.
60. A container for holding product therein during shipment, the container comprising:
a body having at least two walls extending upwardly from a bottom;
a plurality of tracks on opposed walls of said container;
a plurality of generally U-shaped supports, each of said supports being slidable along said tracks; and
dunnage supported by said supports.
61. The container of claim 60 wherein each of said supports includes end members and a non-linear support member extending between said end members.
62. The container of claim 60 wherein said dunnage comprises pouches.

63. The container of claim 60 wherein said dunnage comprises multiple pouches supported by a pair of said supports.

1/27

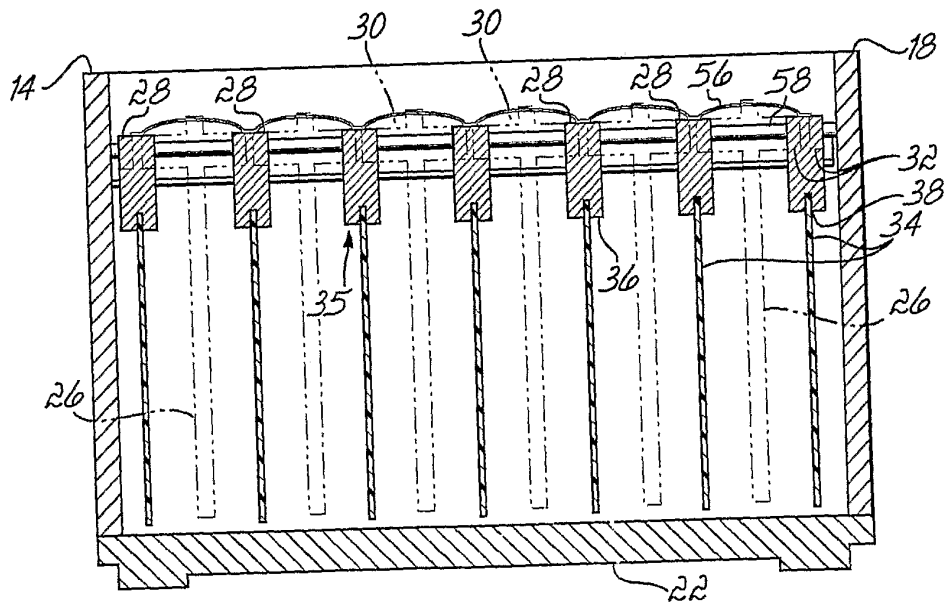
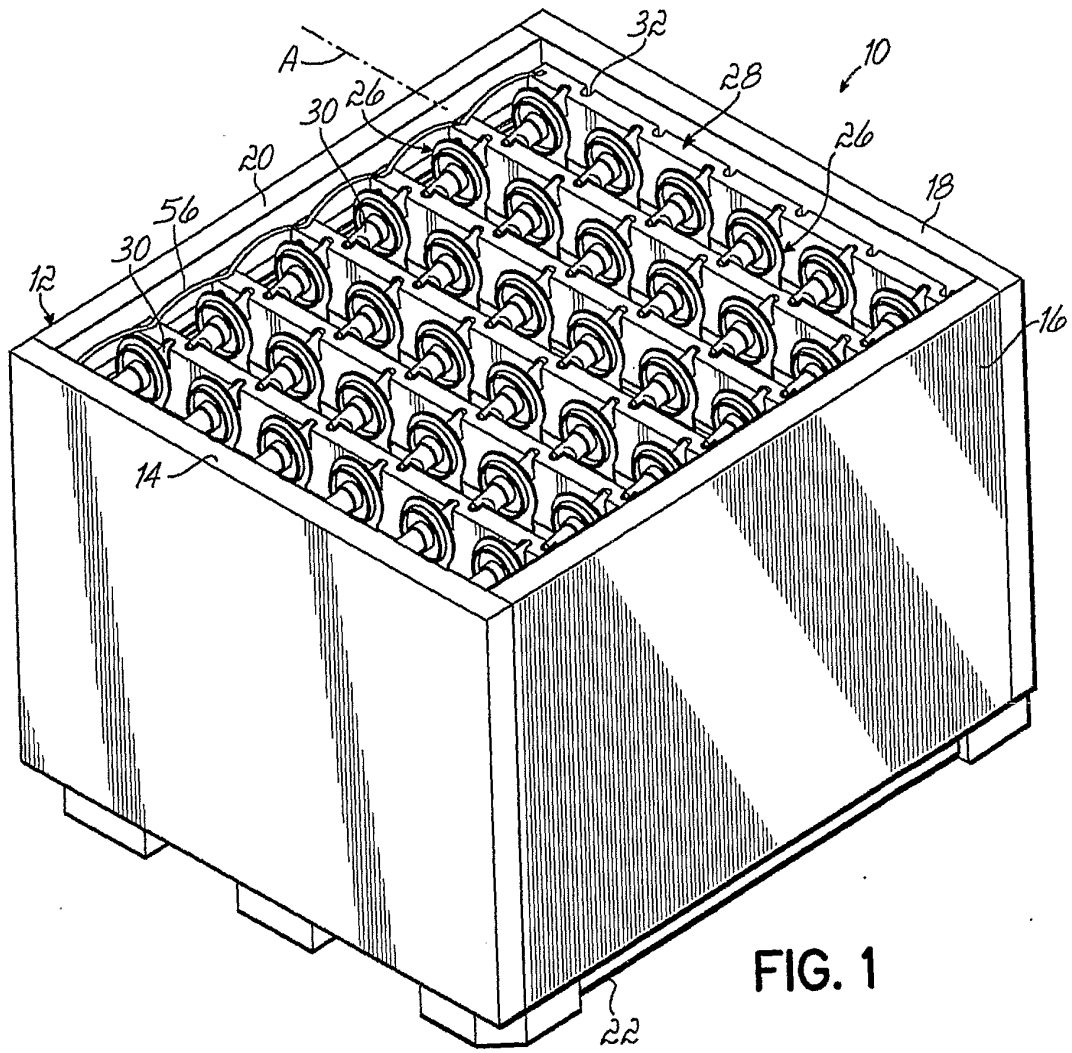

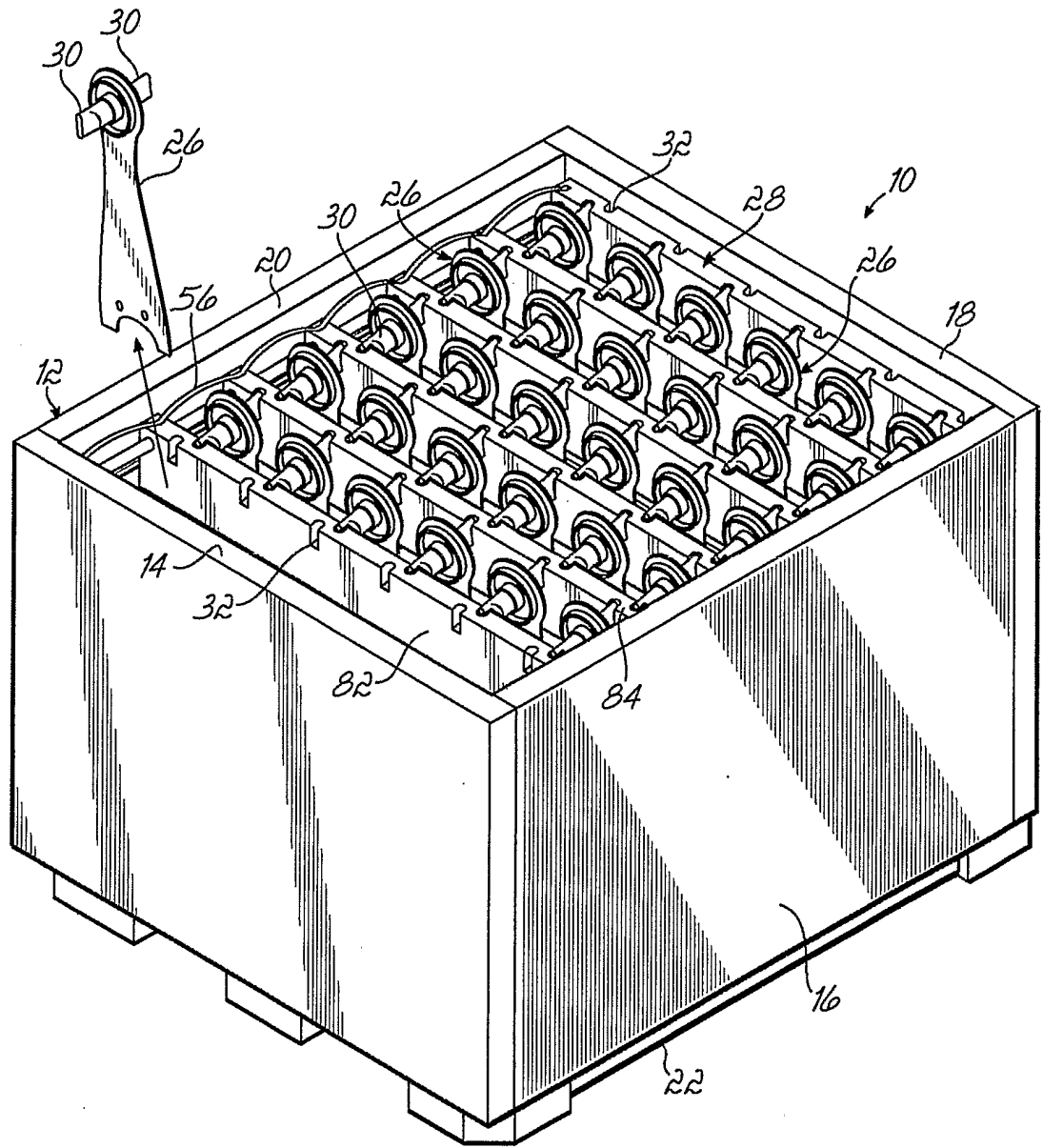

FIG. 2

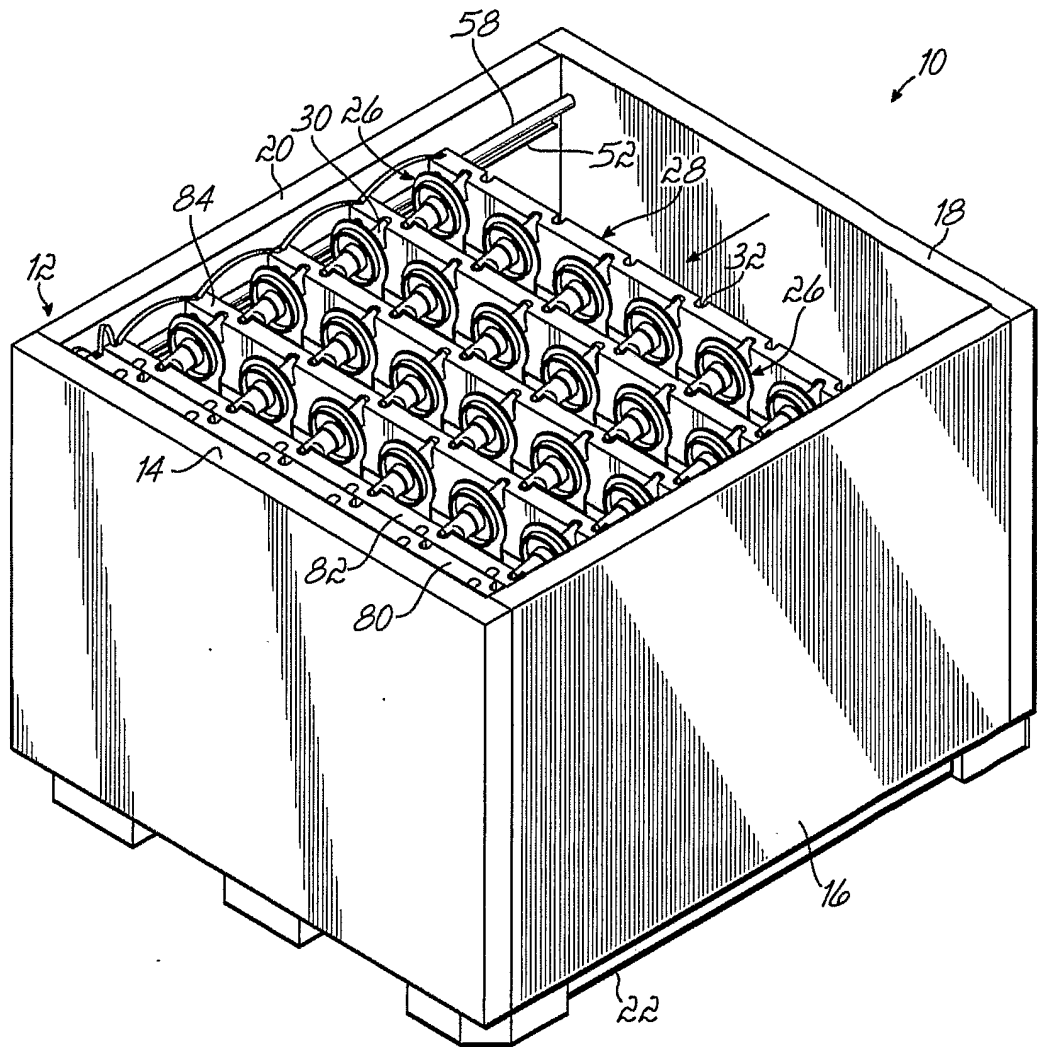

FIG. 3

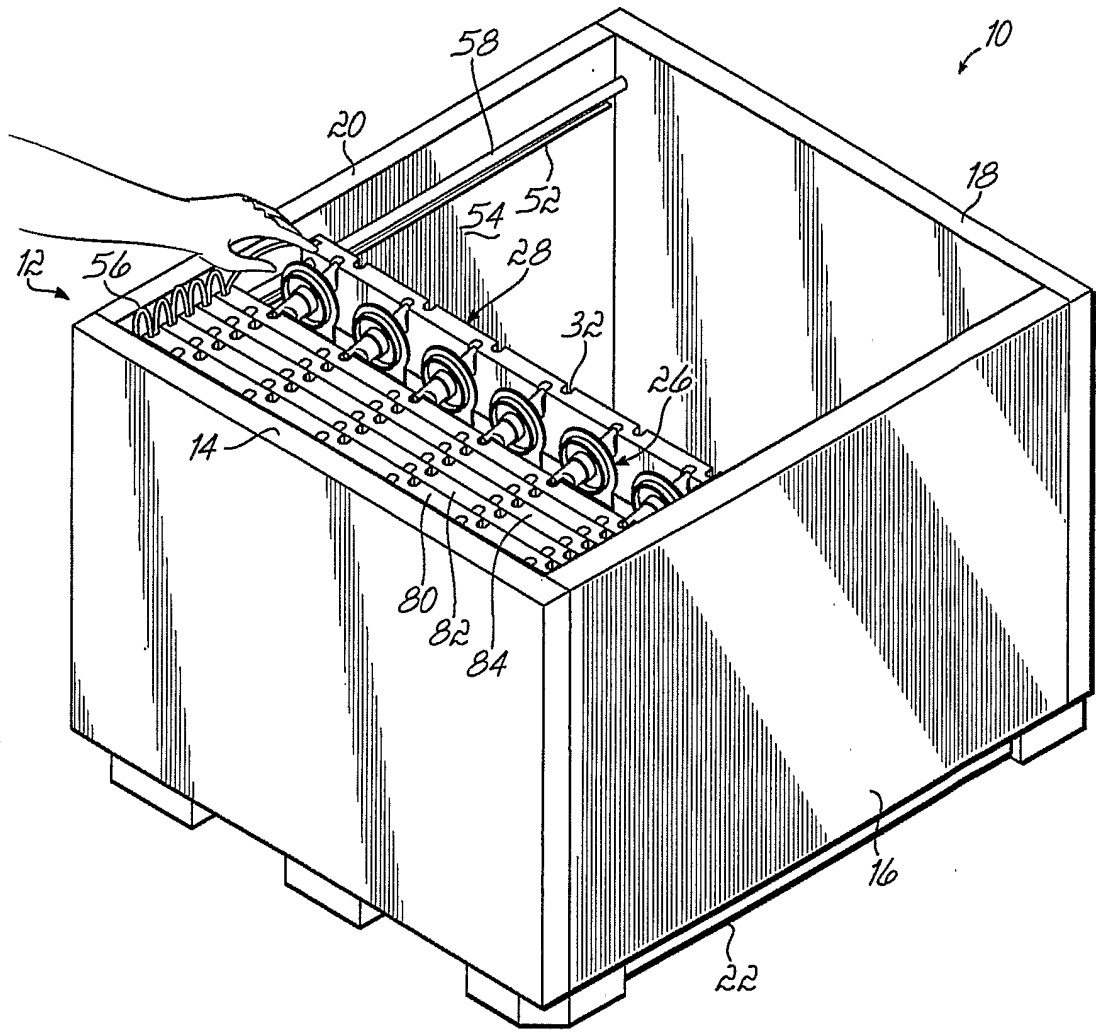

FIG. 4

5/27

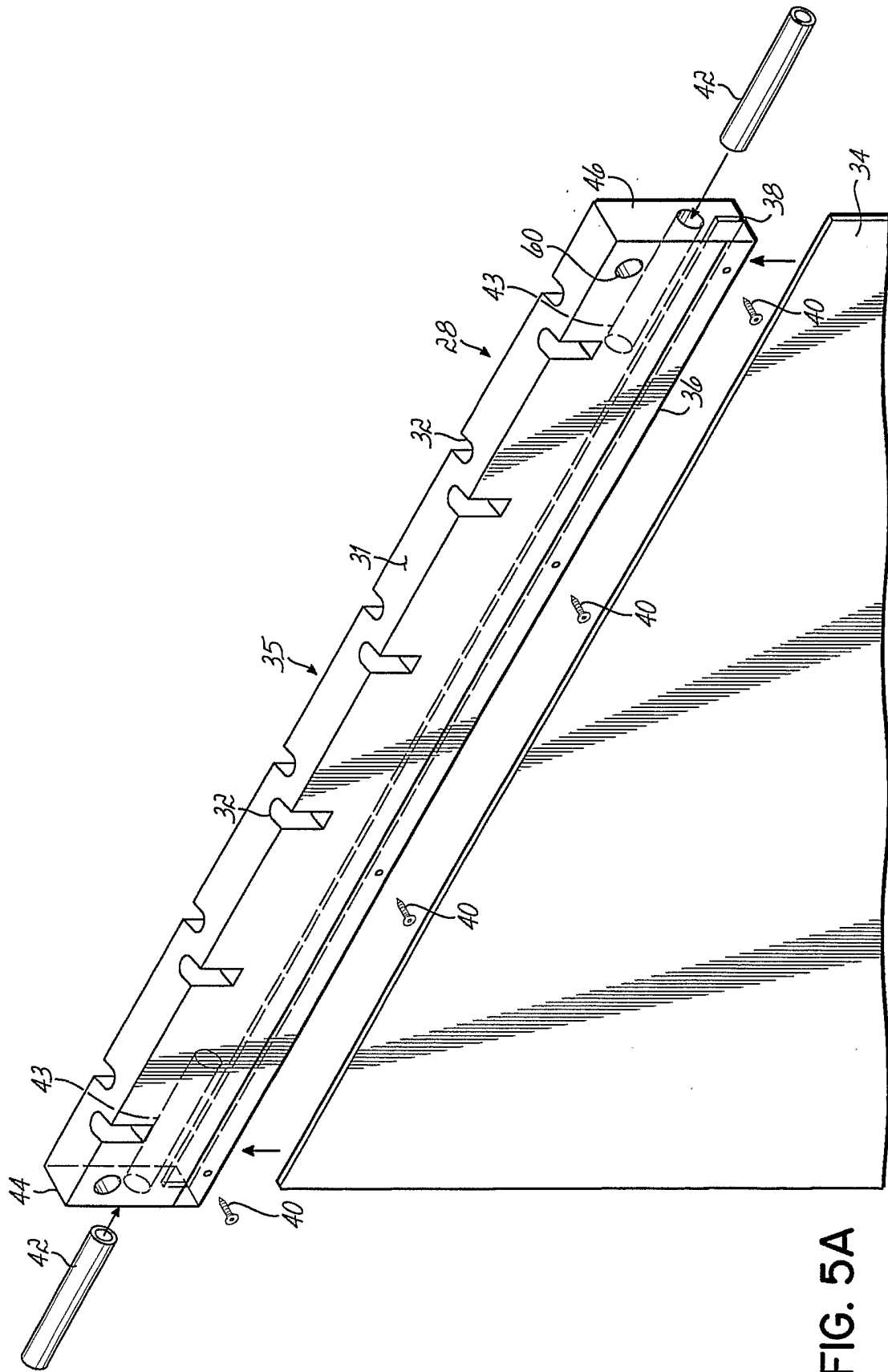

FIG. 5A

6/27

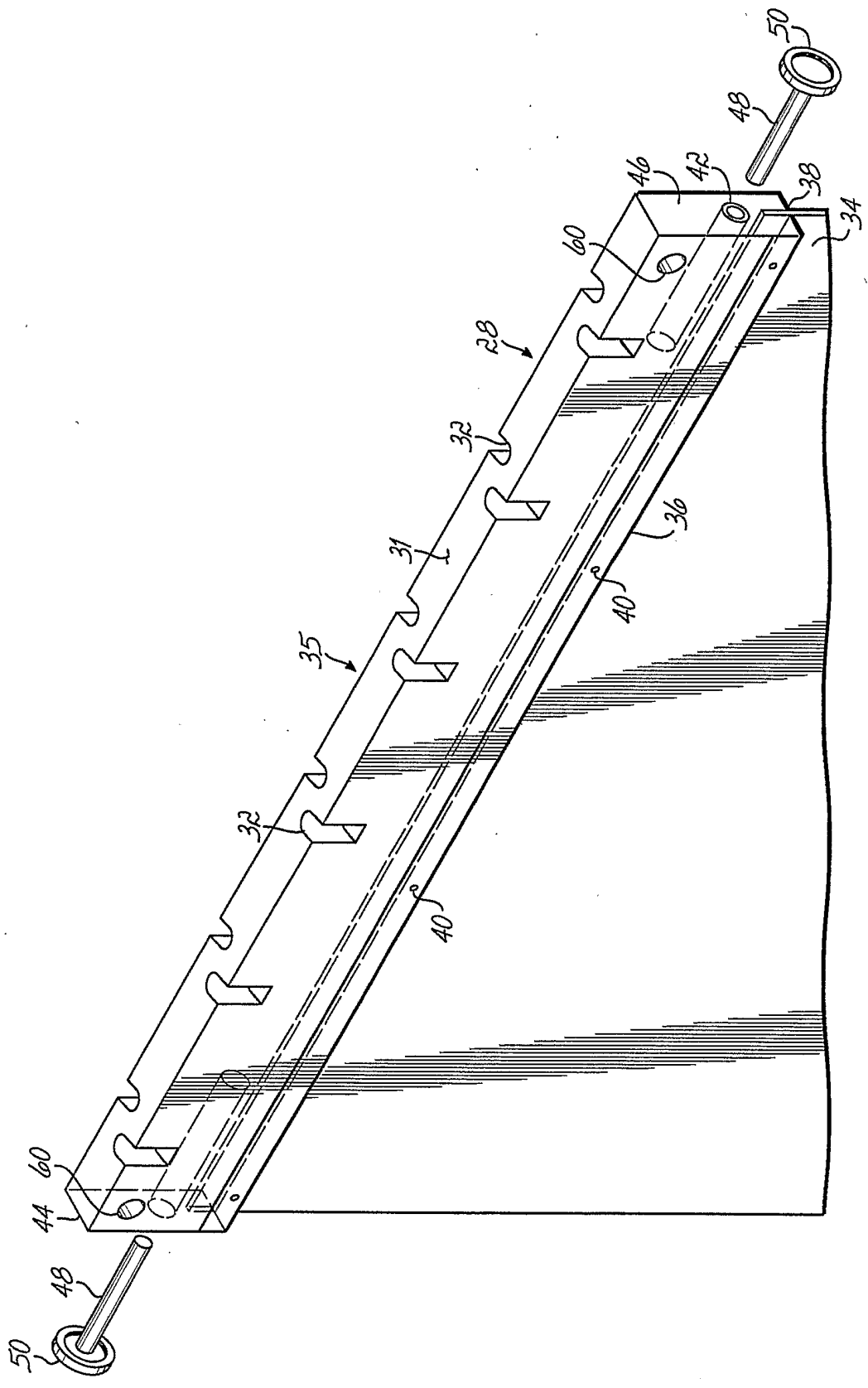

FIG. 5B

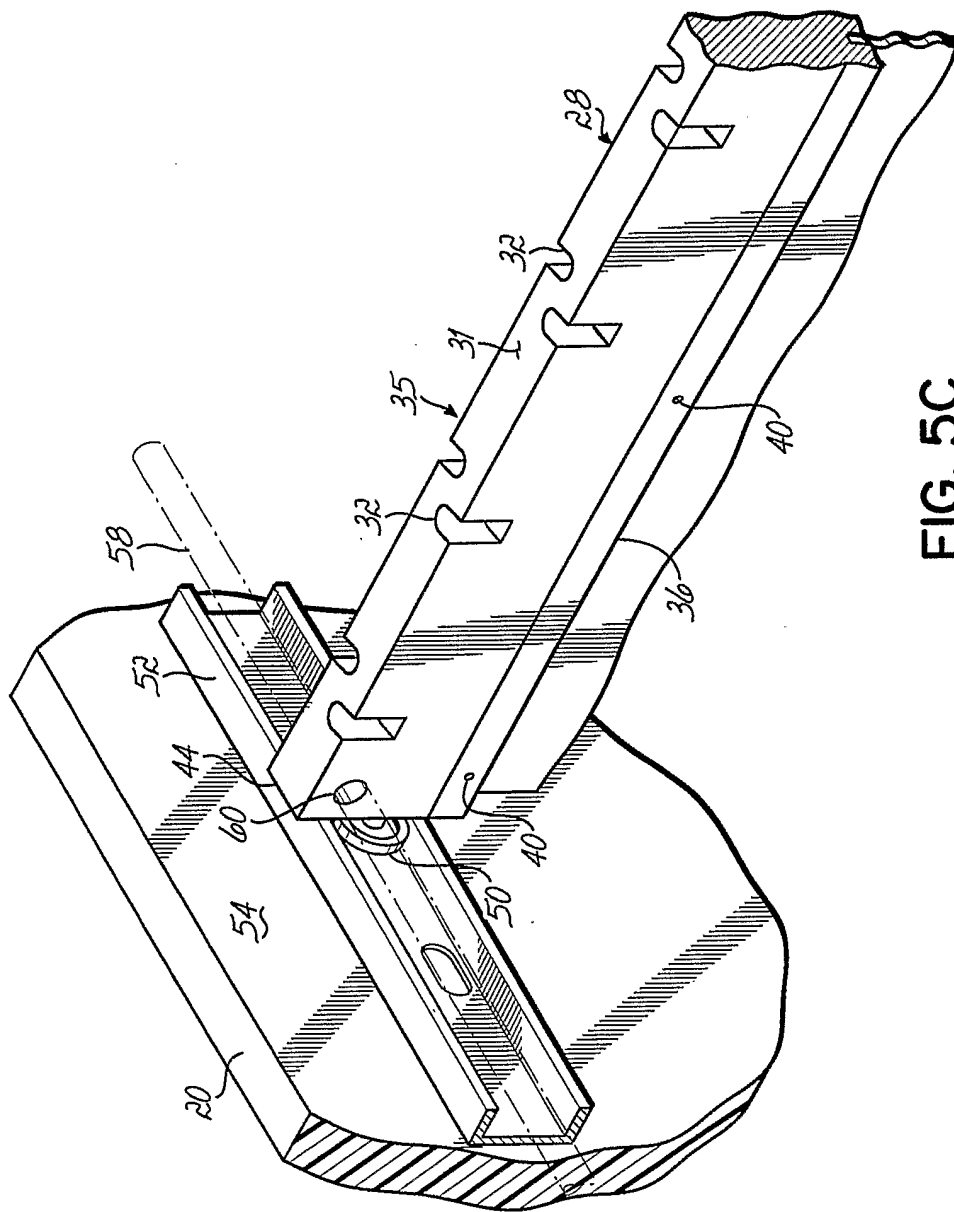

FIG. 5C

8/27

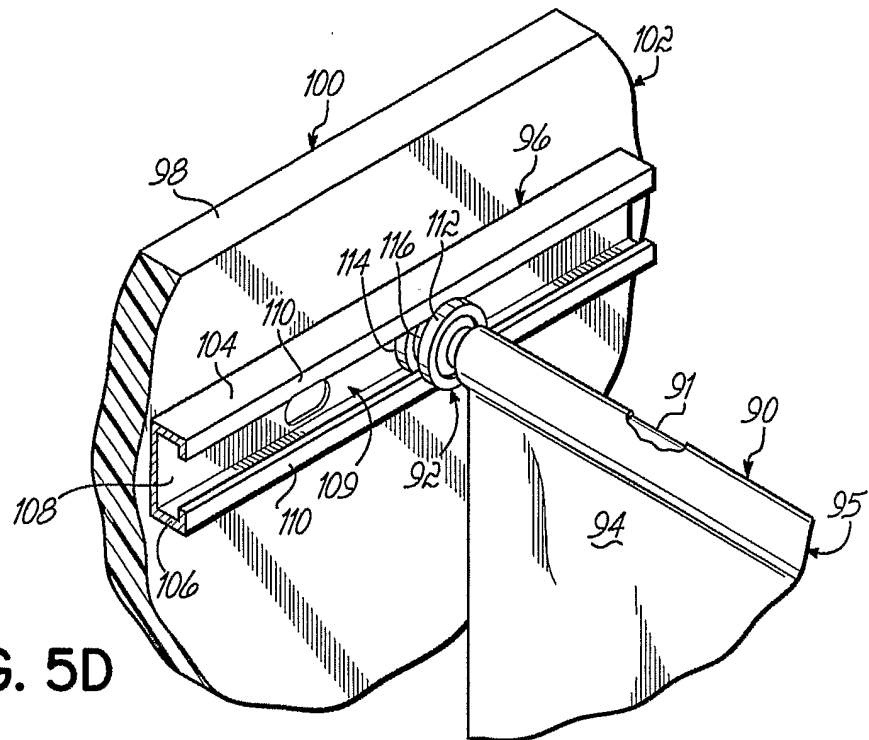

FIG. 5D

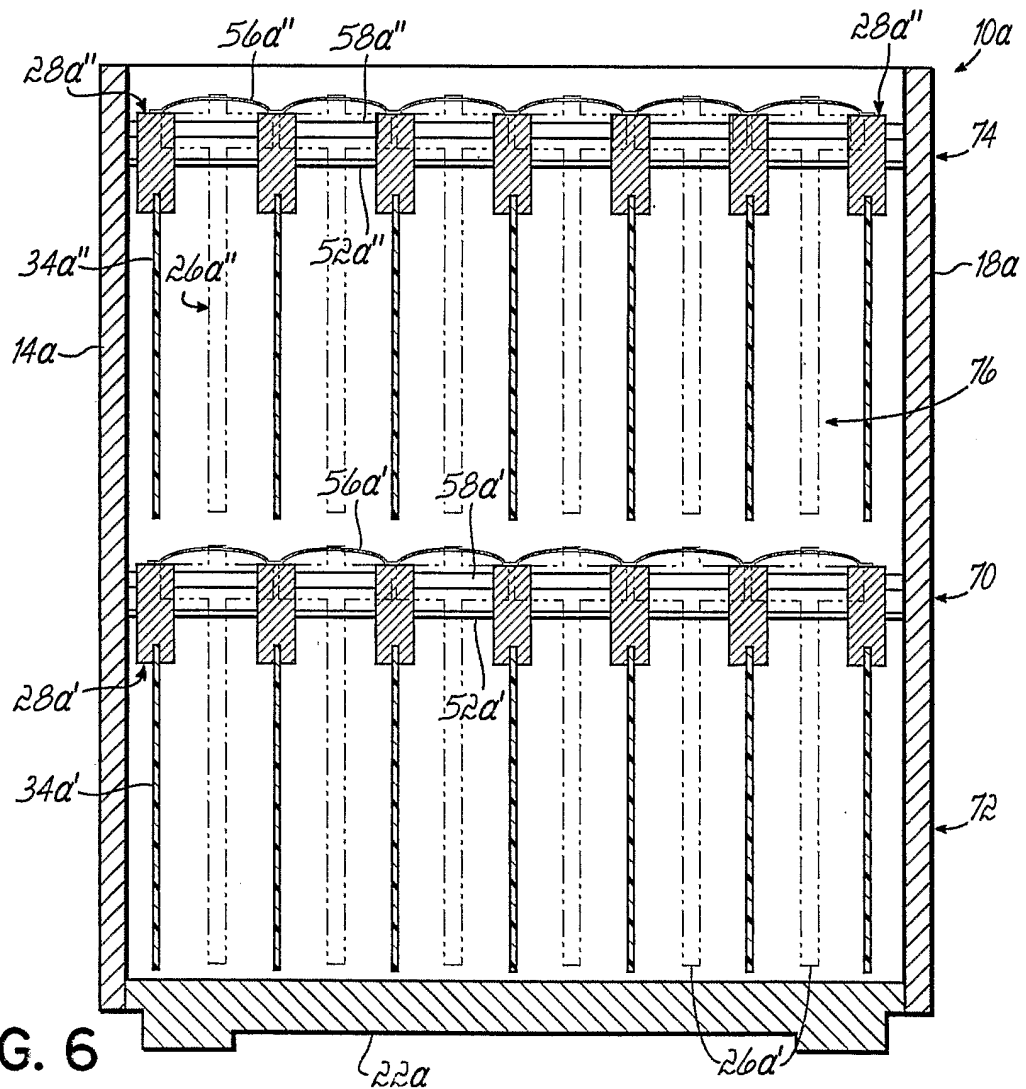

FIG. 6

9/27

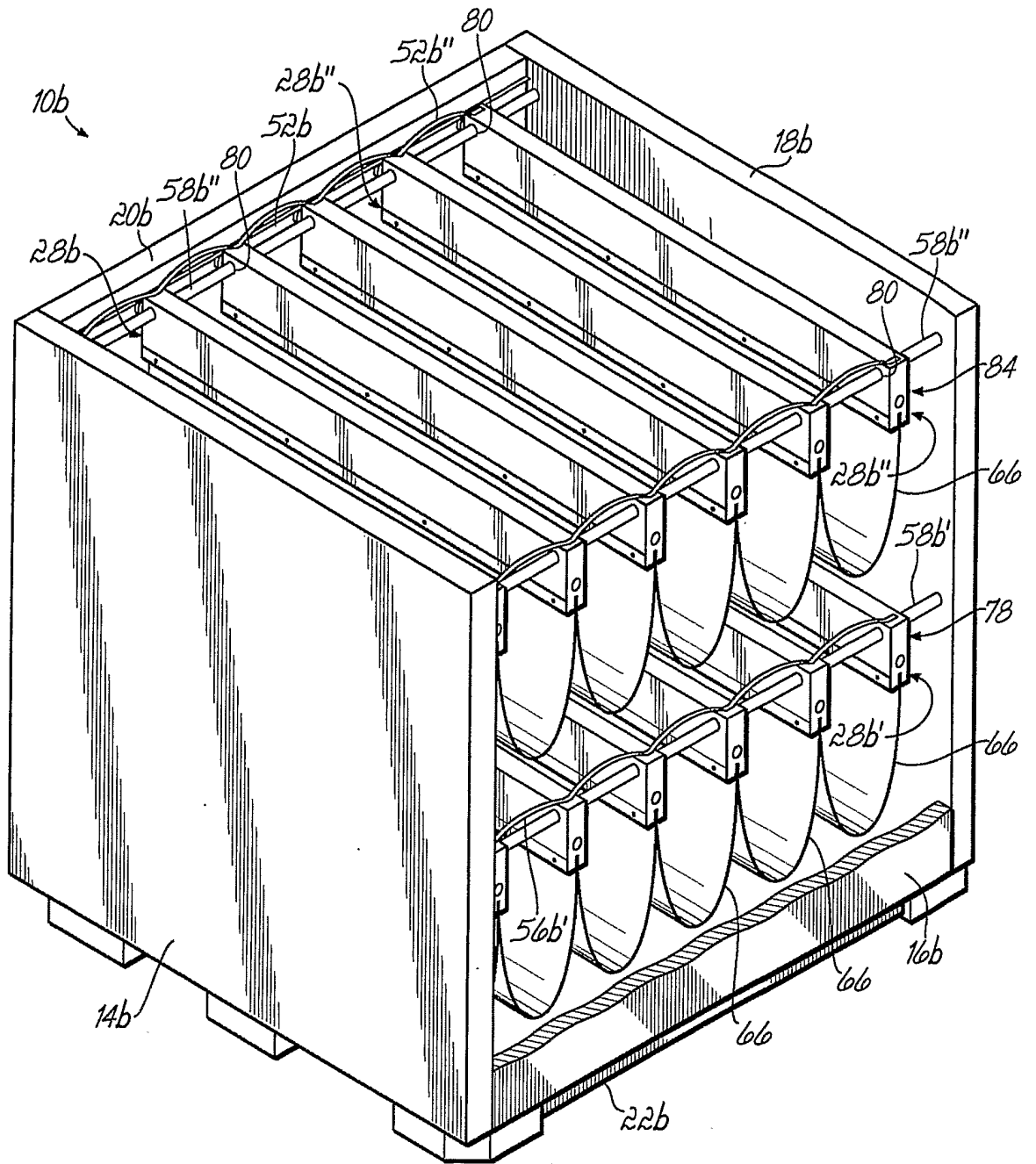

FIG. 7

10/27

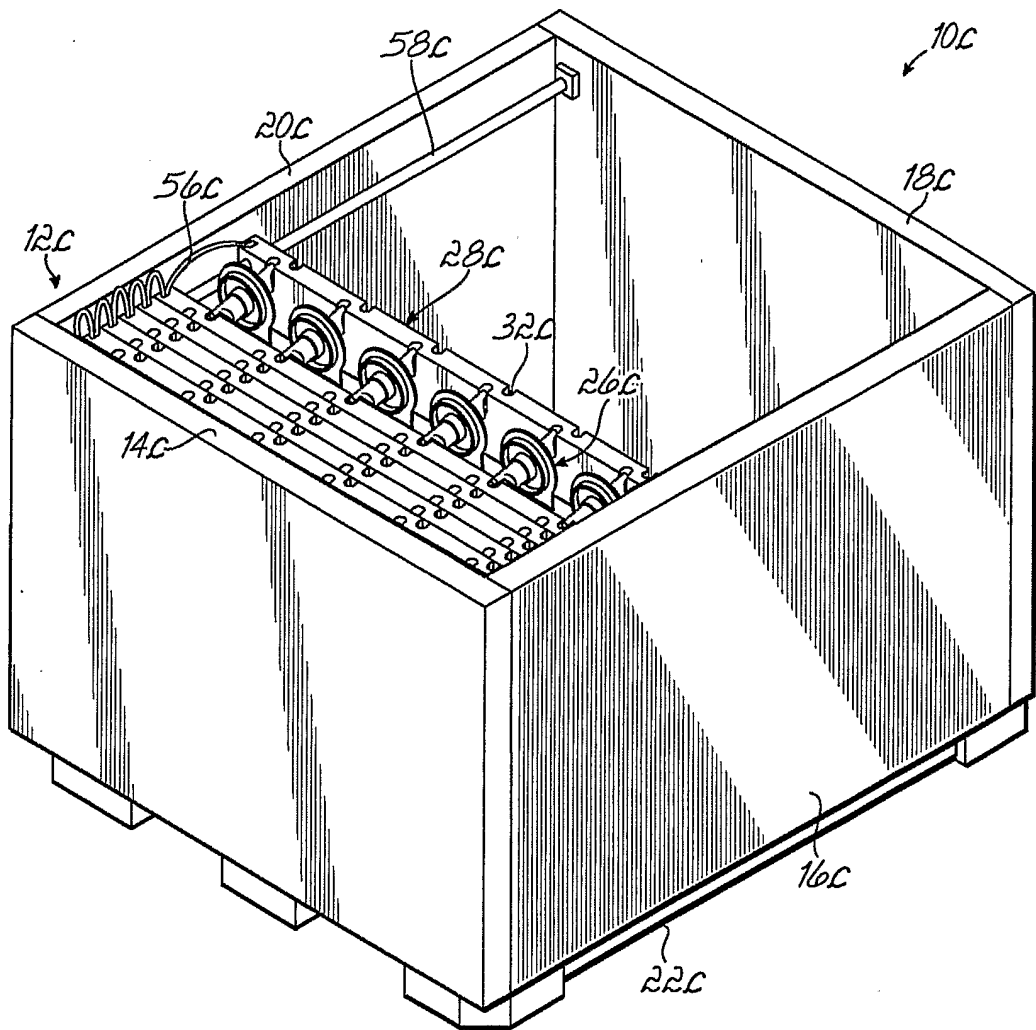

FIG. 8

11/27

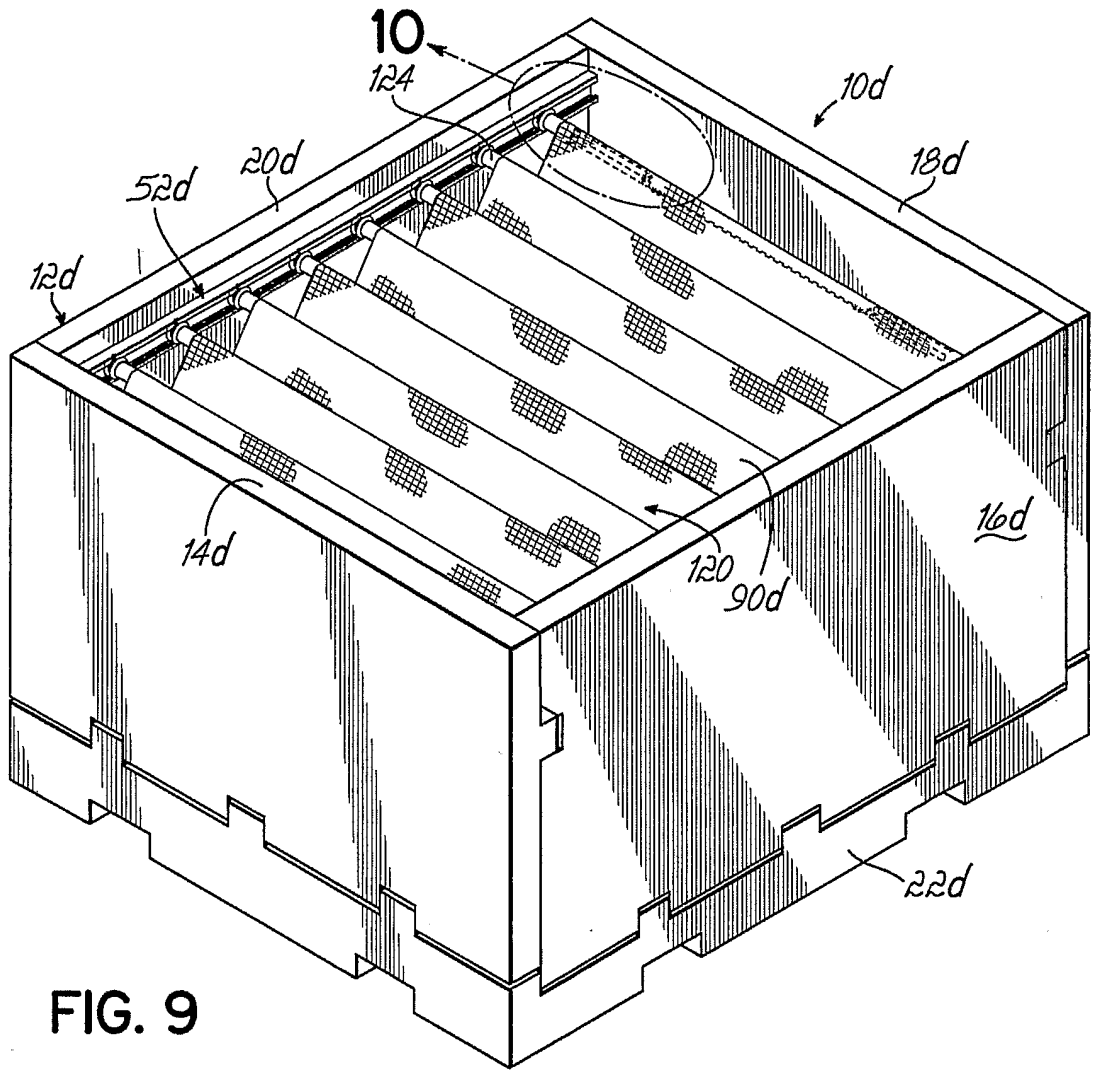

FIG. 9

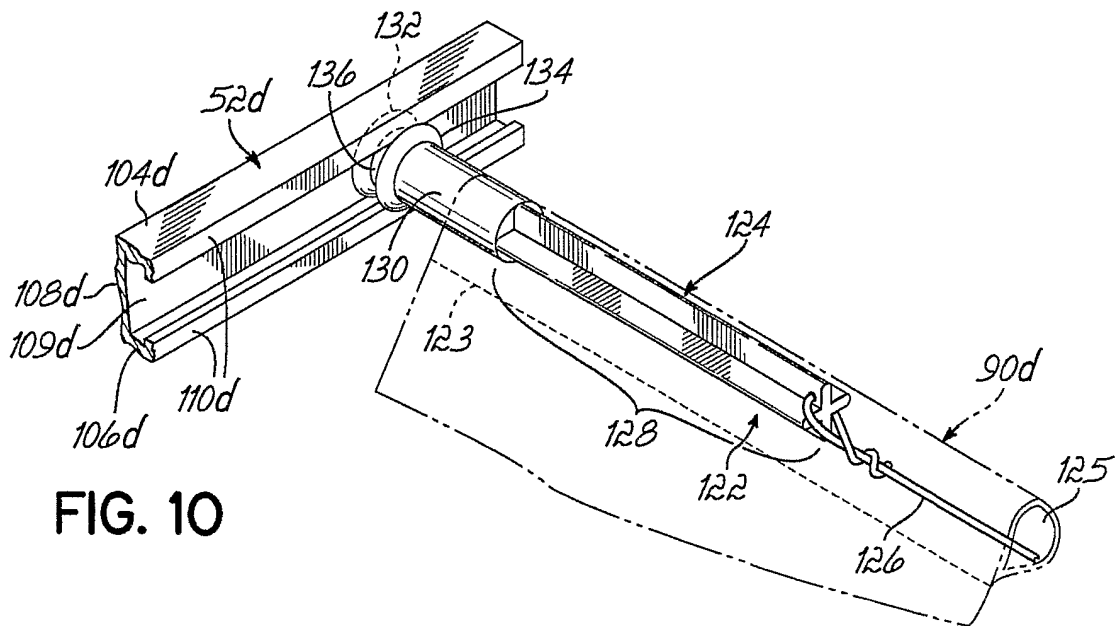

FIG. 10

12/27

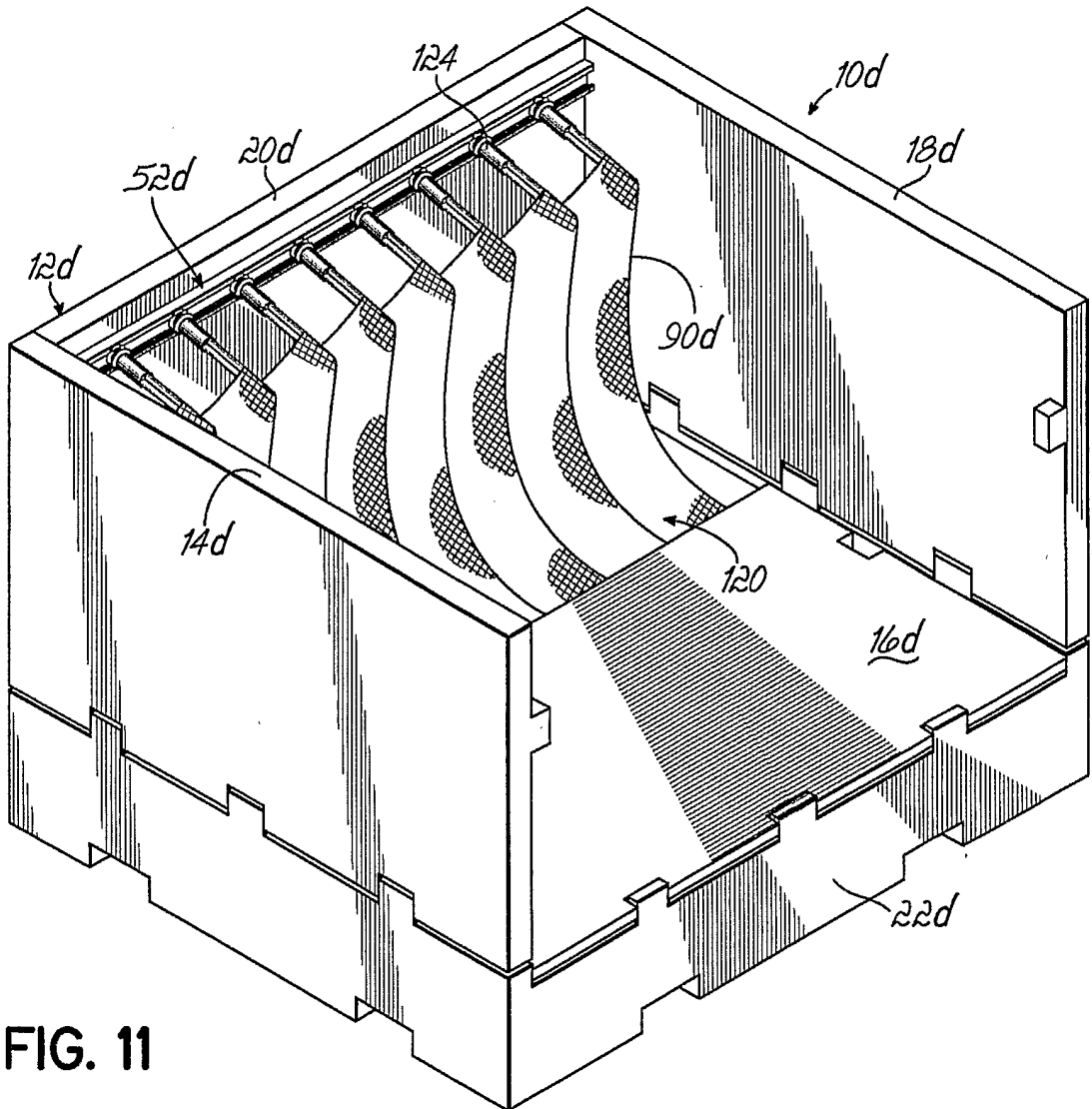

FIG. 11

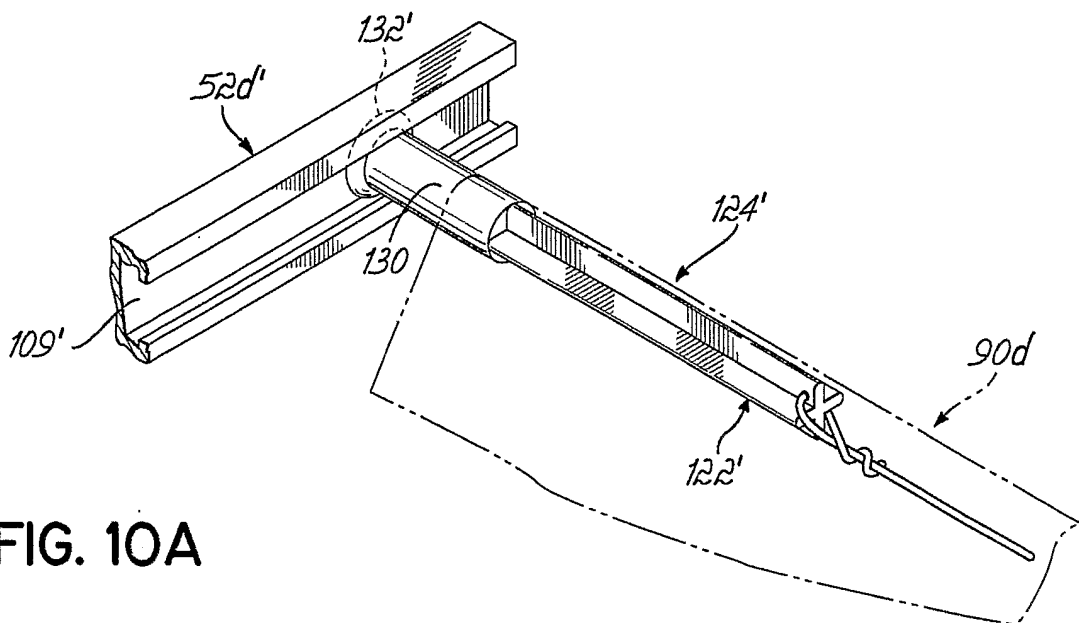

FIG. 10A

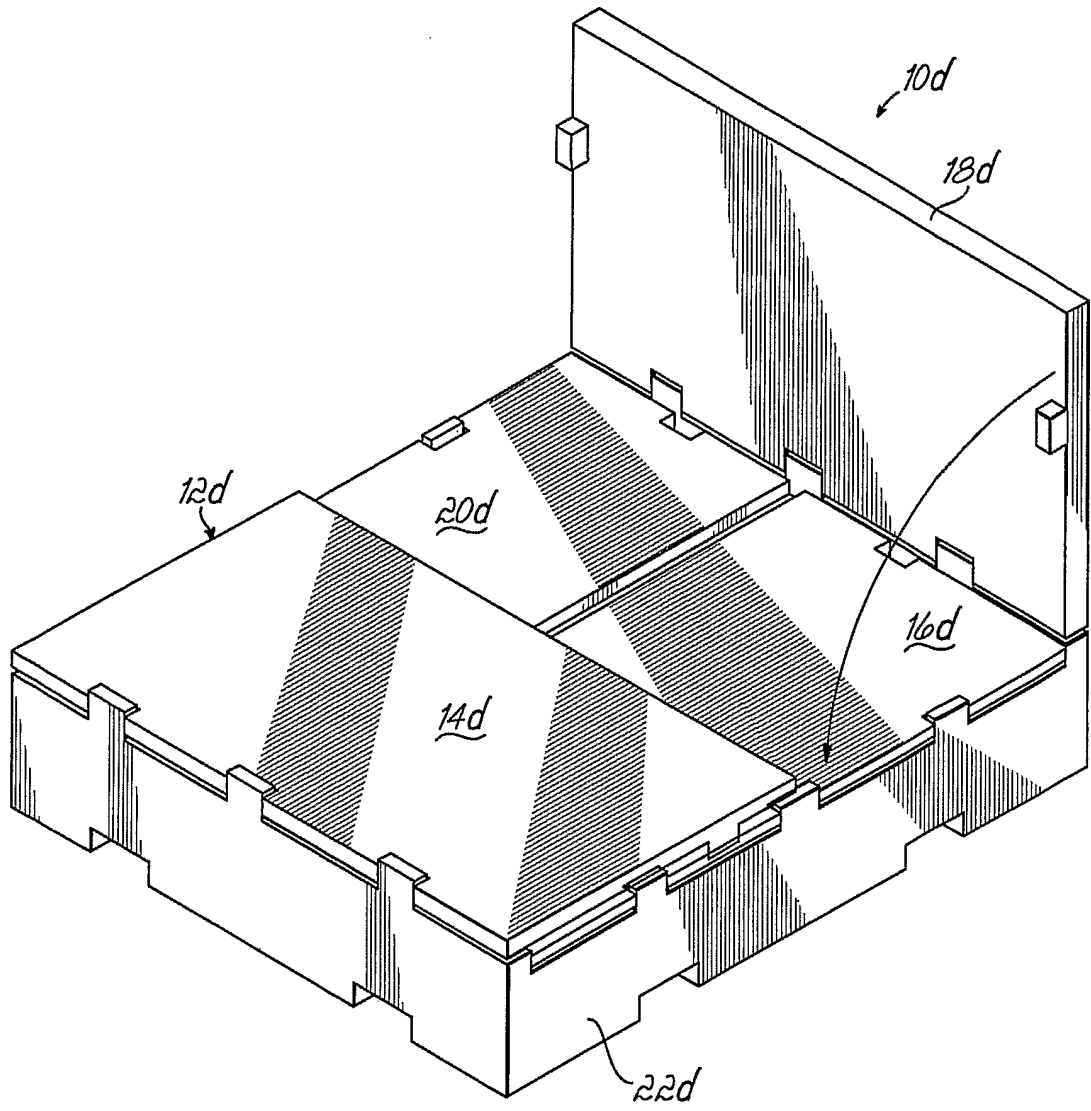

FIG. 12

14/27

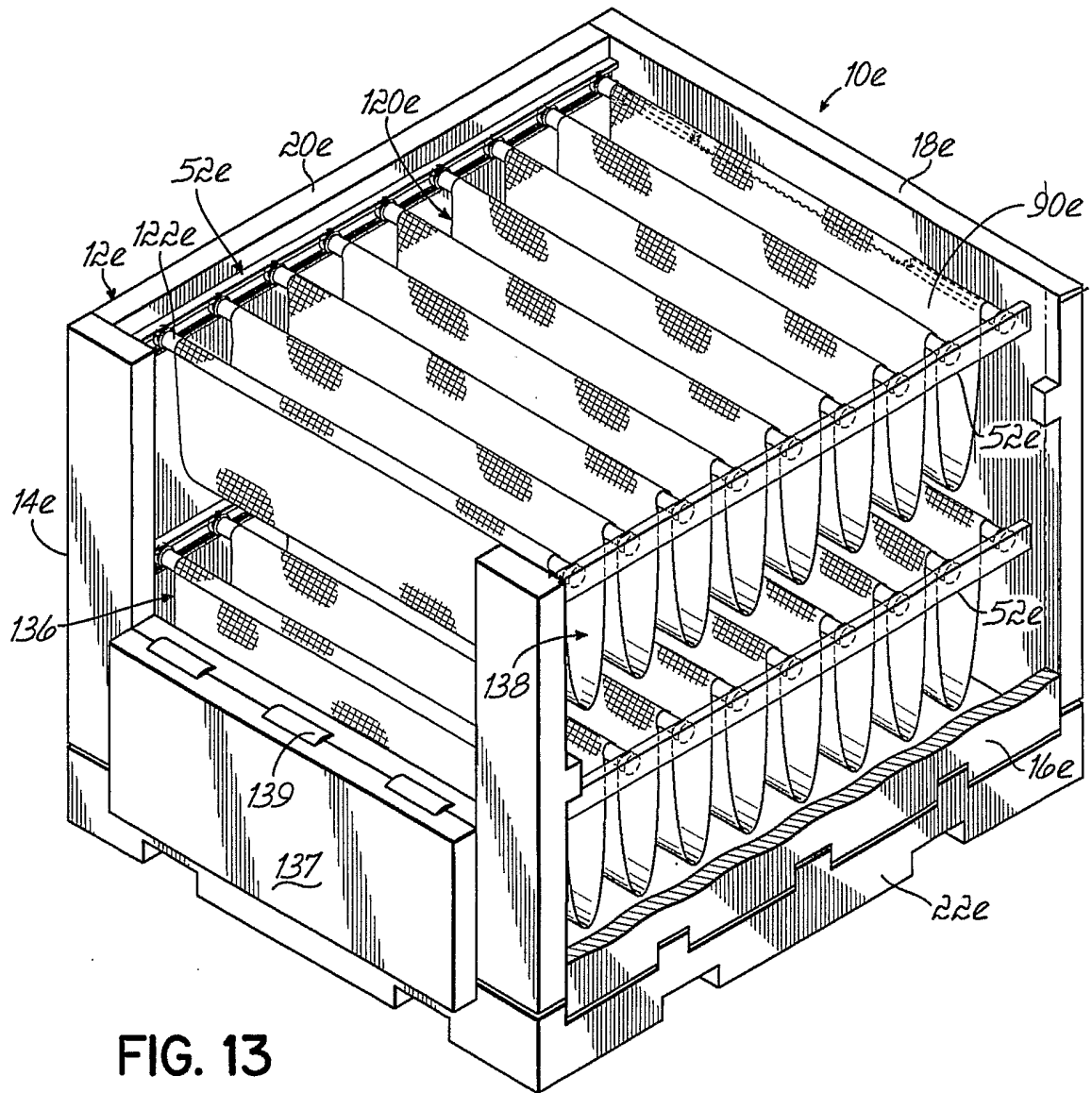

FIG. 13

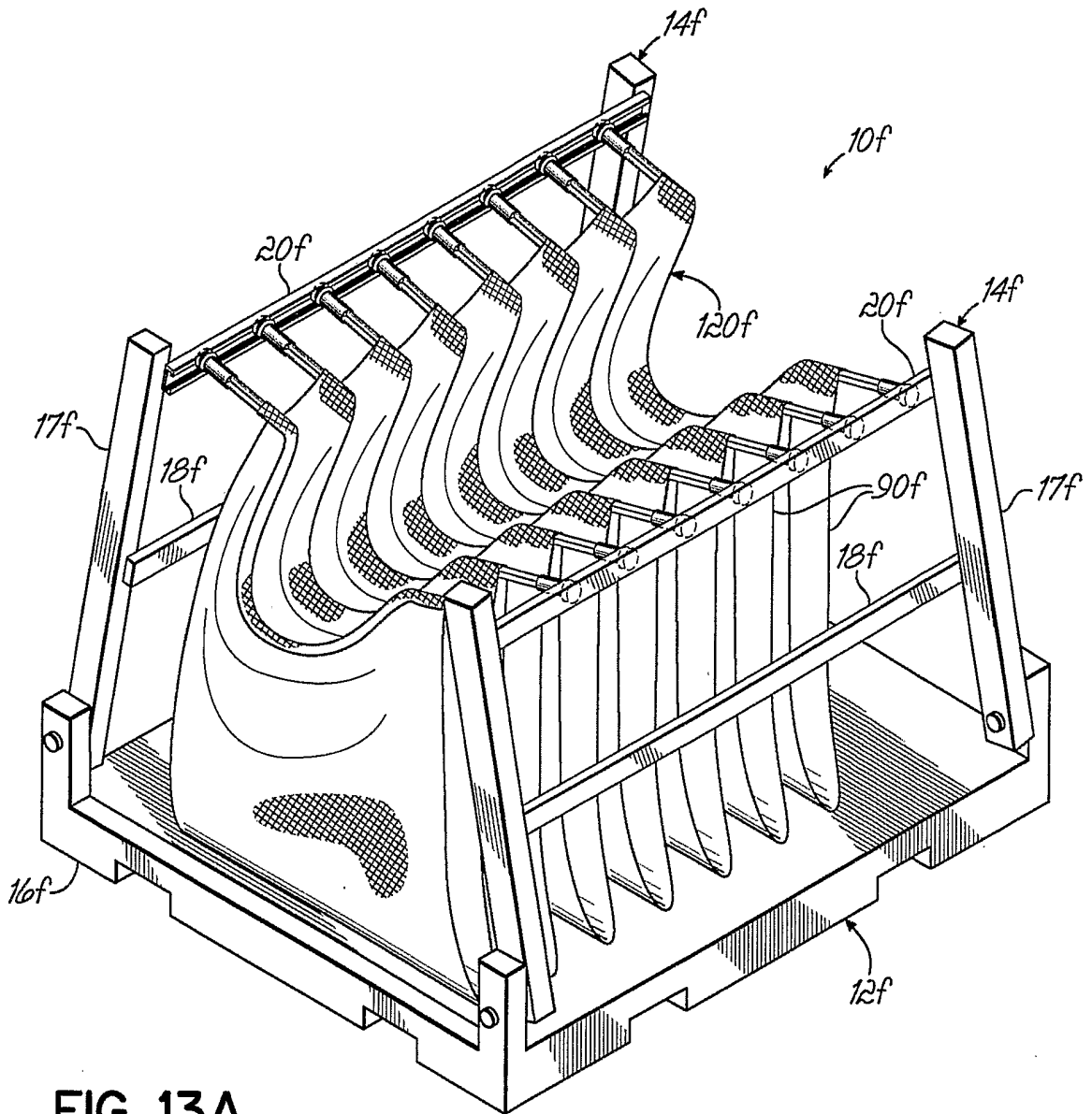

FIG. 13A

16/27

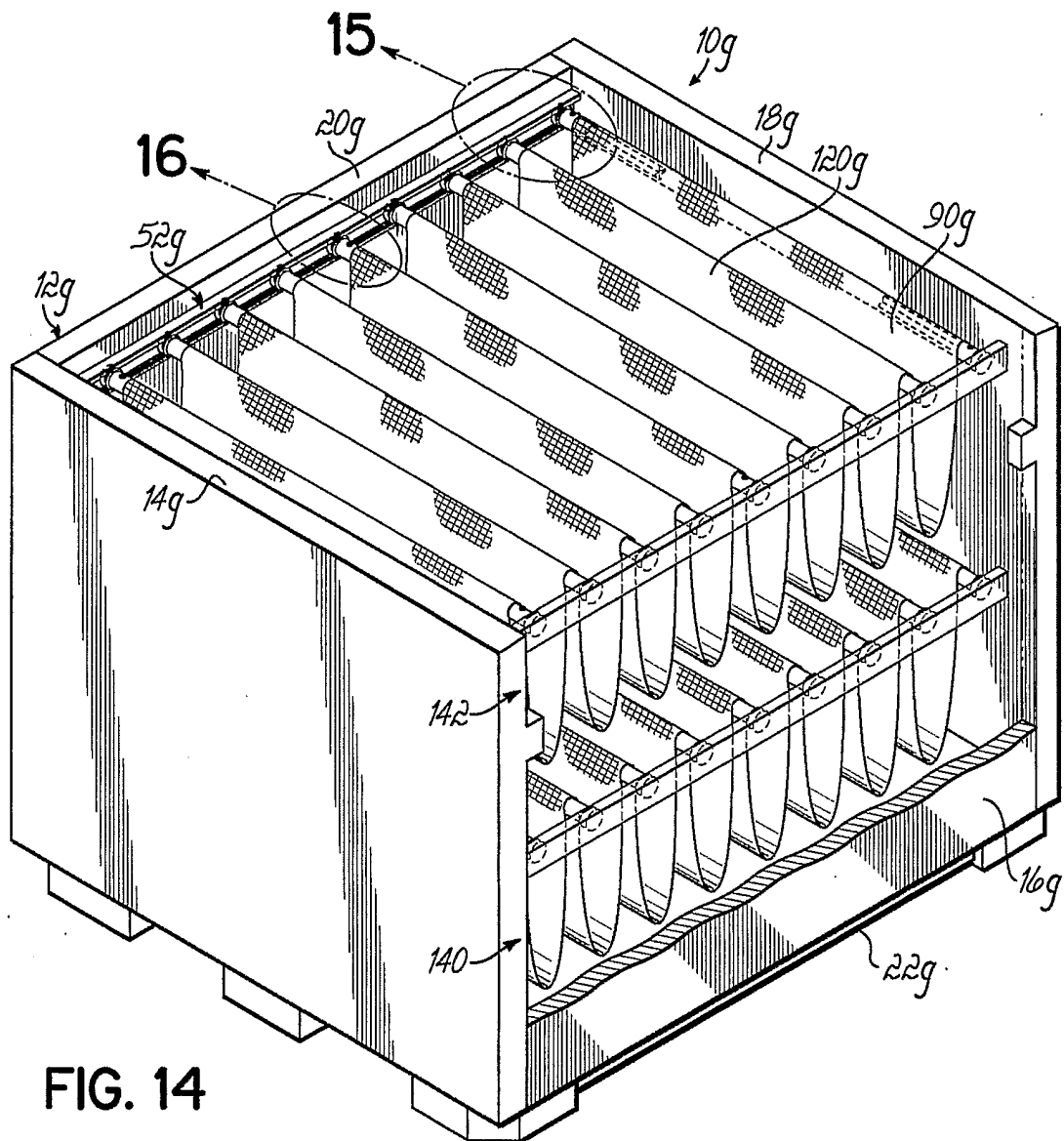

FIG. 14

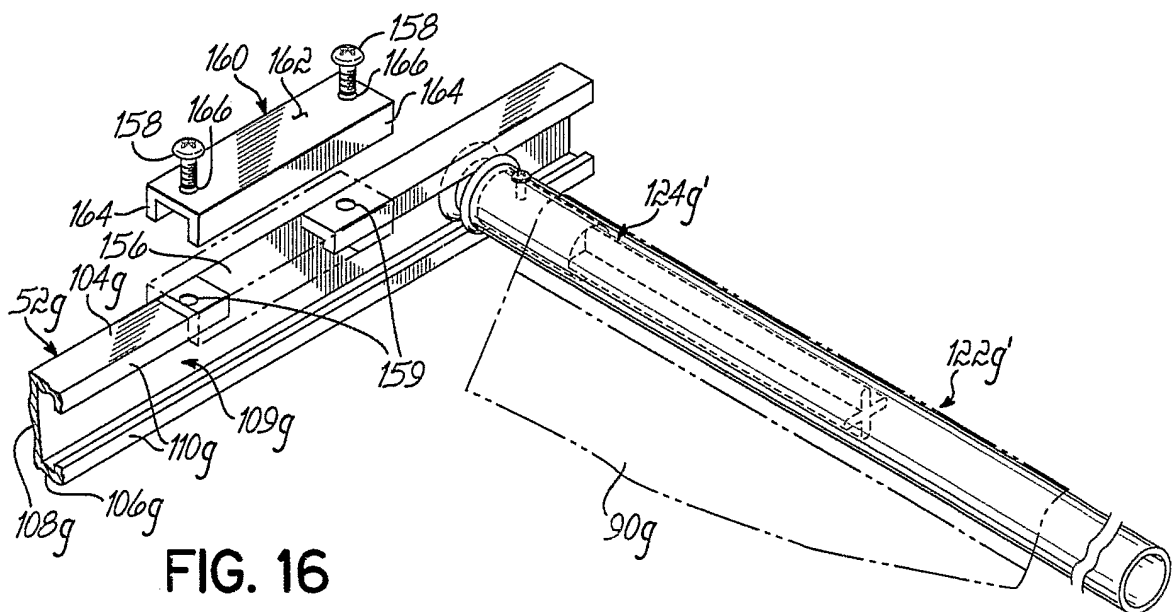

FIG. 16

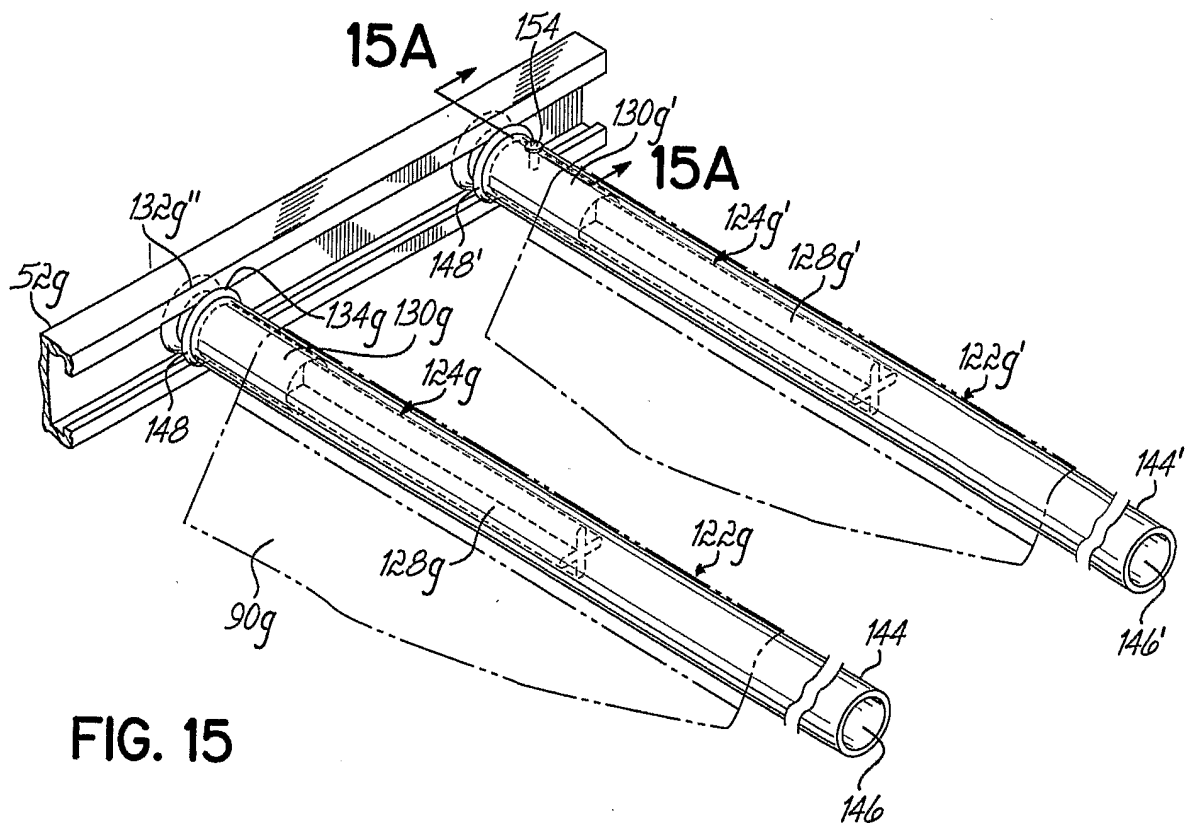

FIG. 15

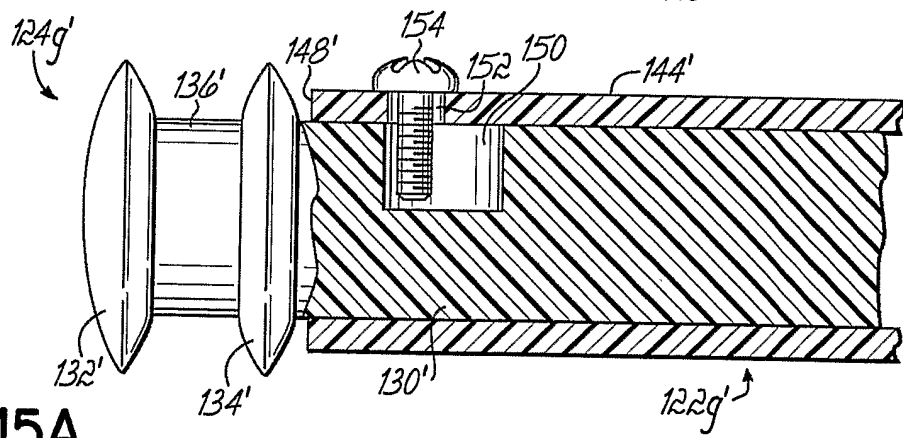

FIG. 15A

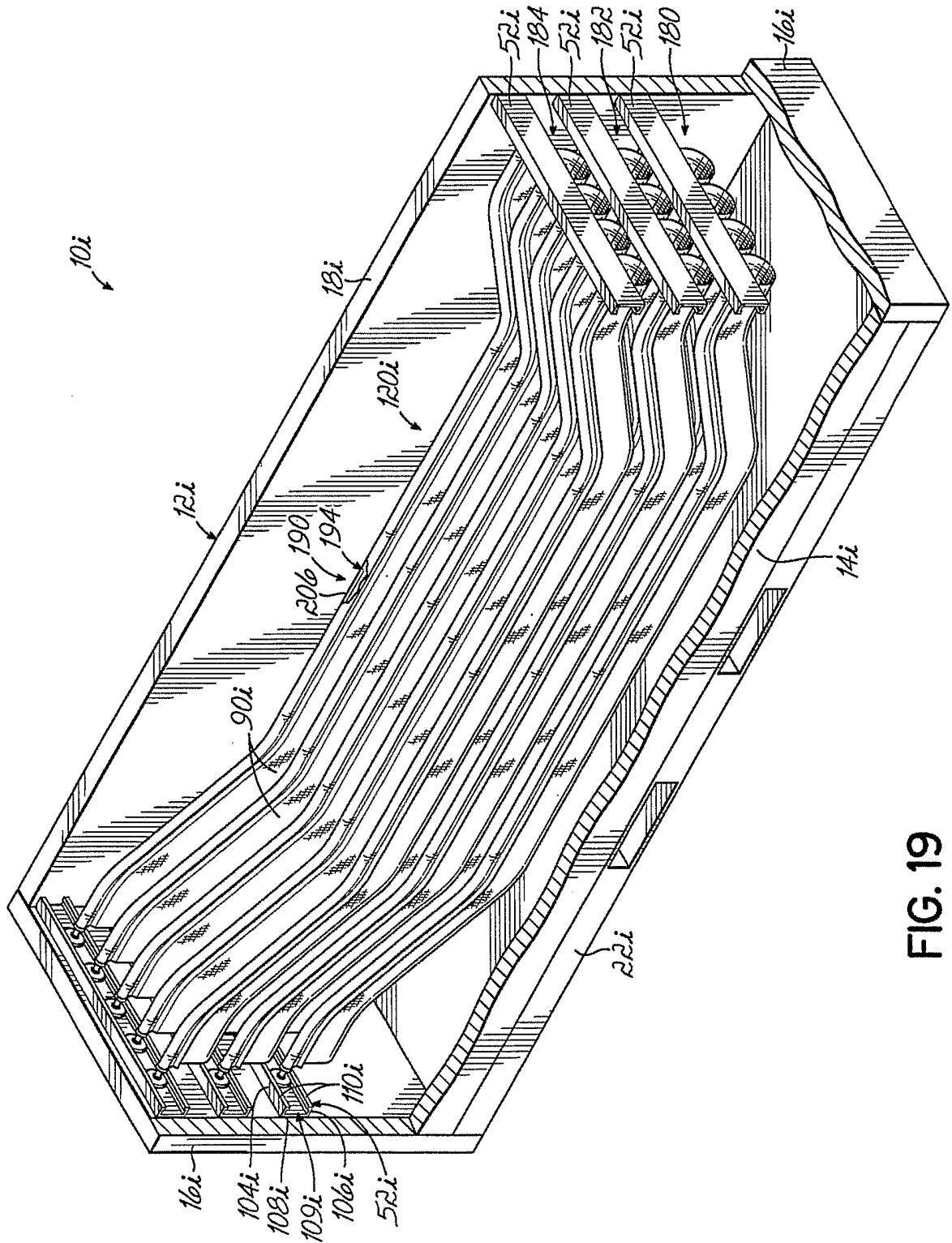

FIG. 19

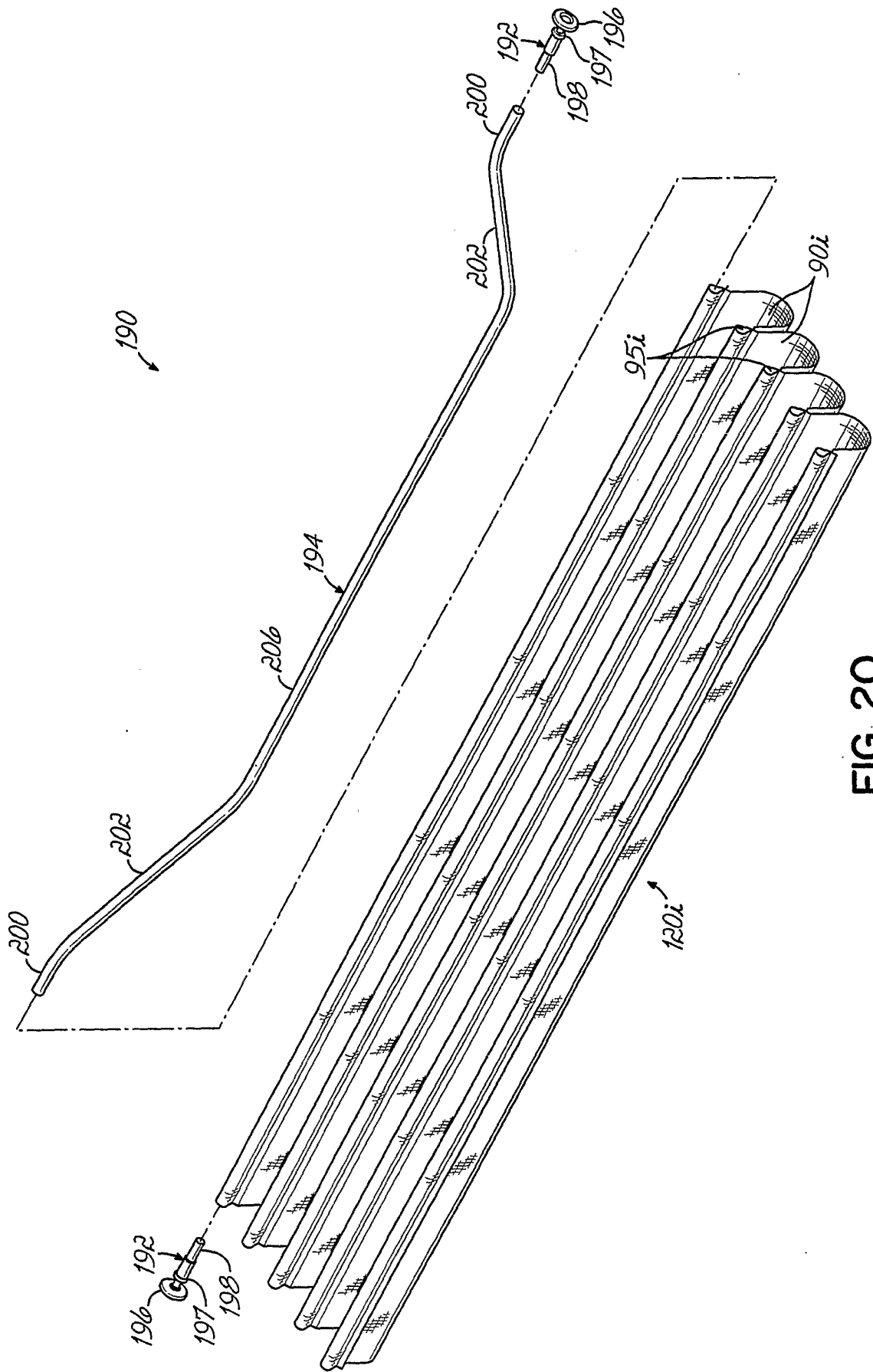

FIG. 20

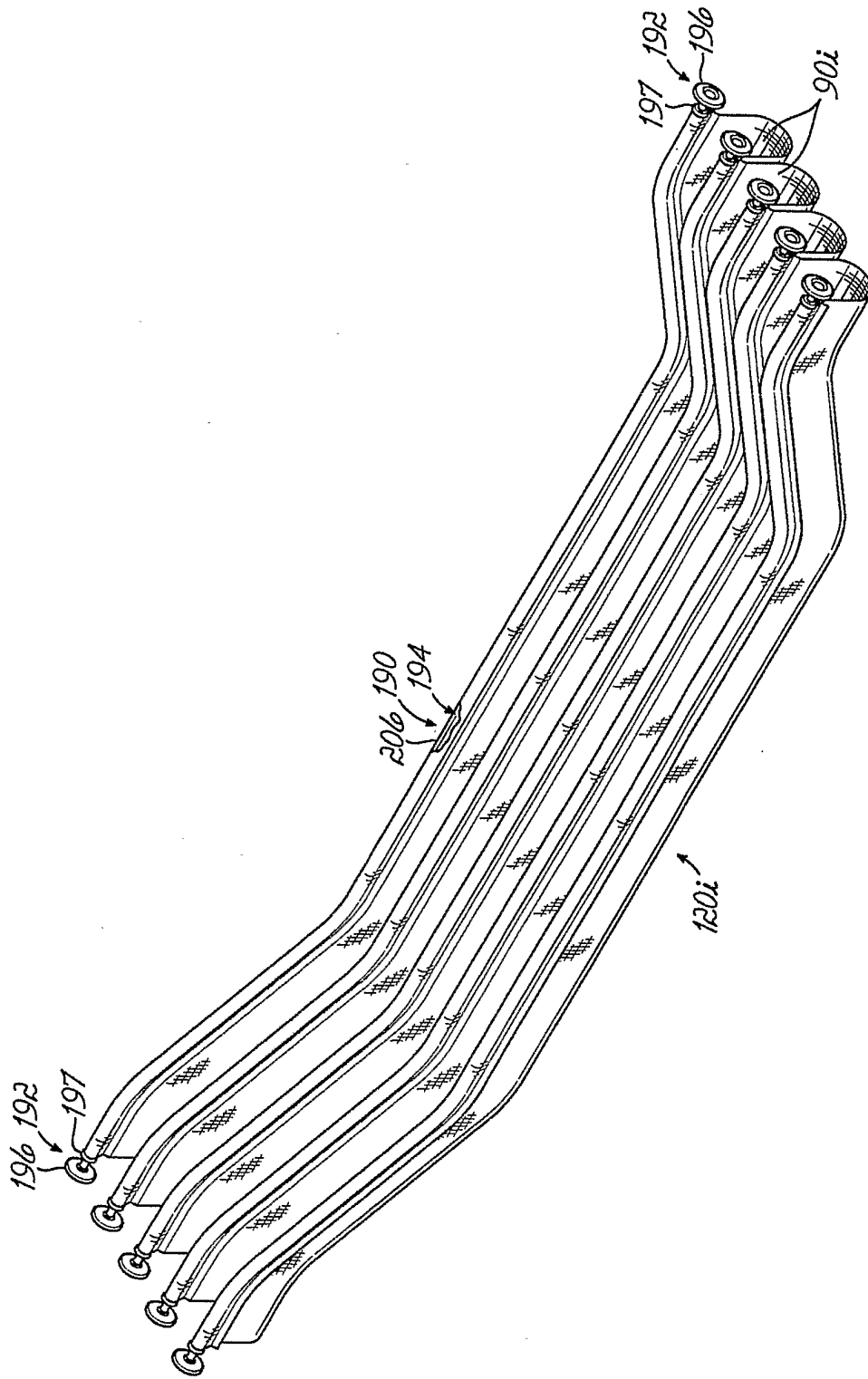

FIG. 21

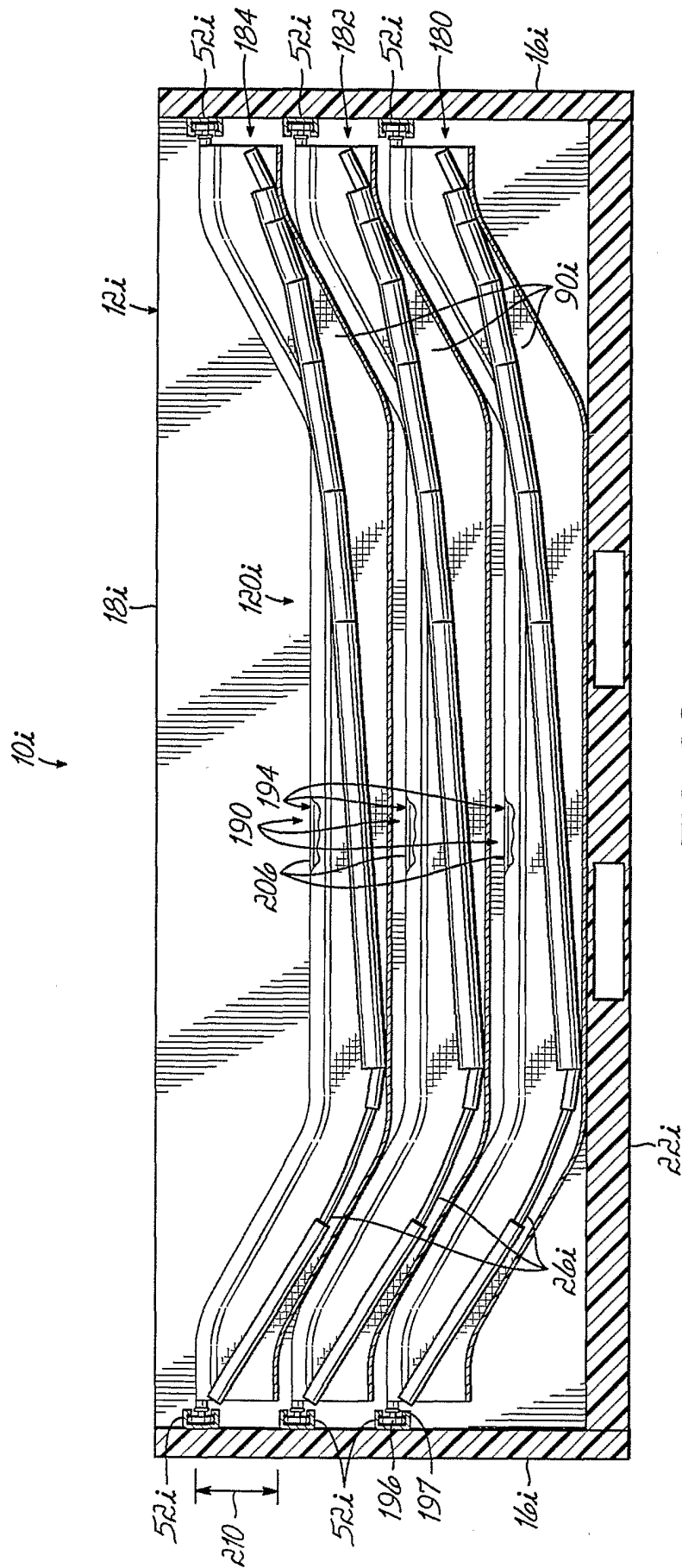

FIG. 22

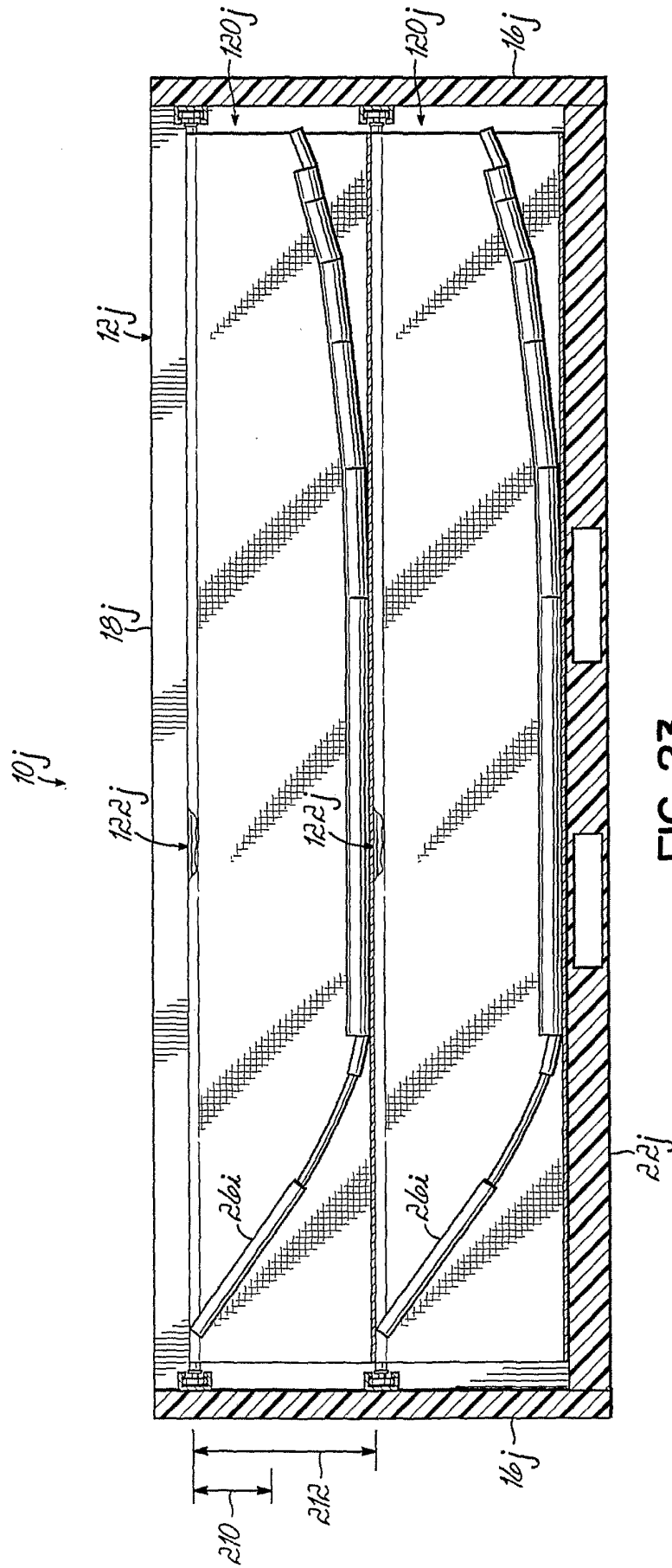

FIG. 23

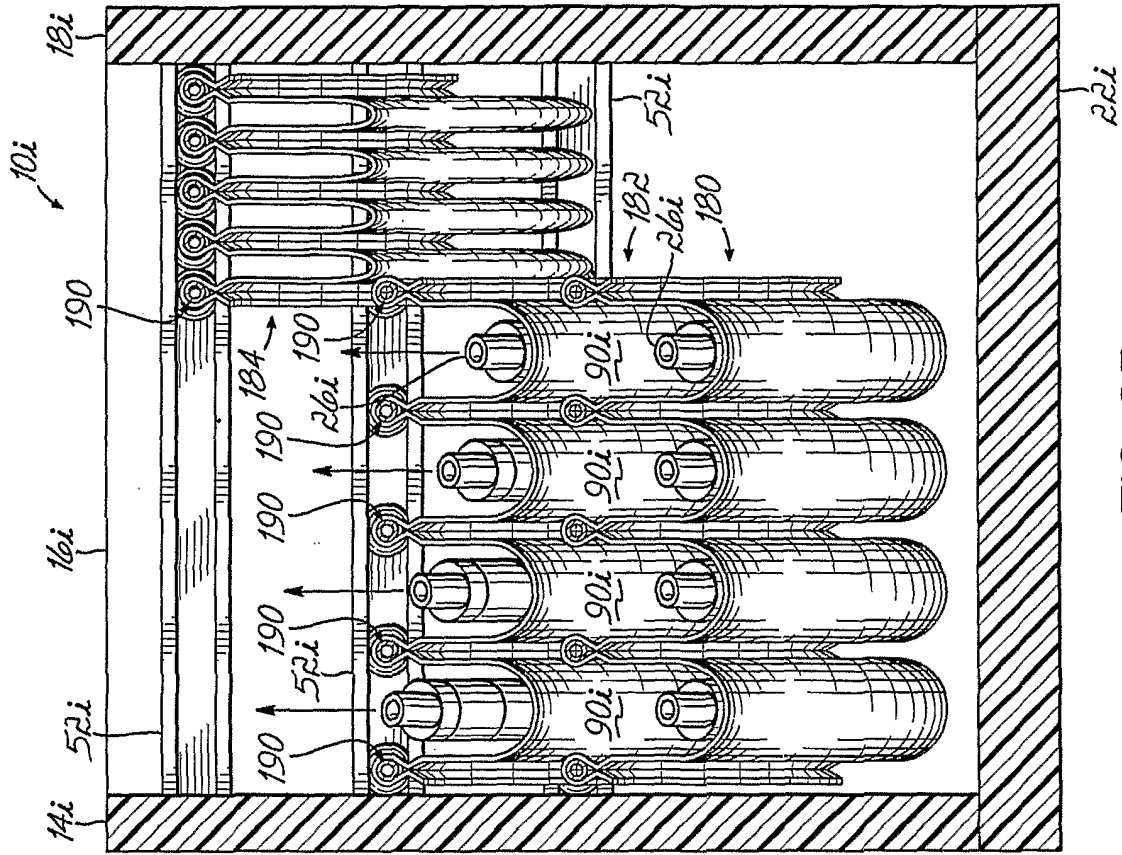

FIG. 25

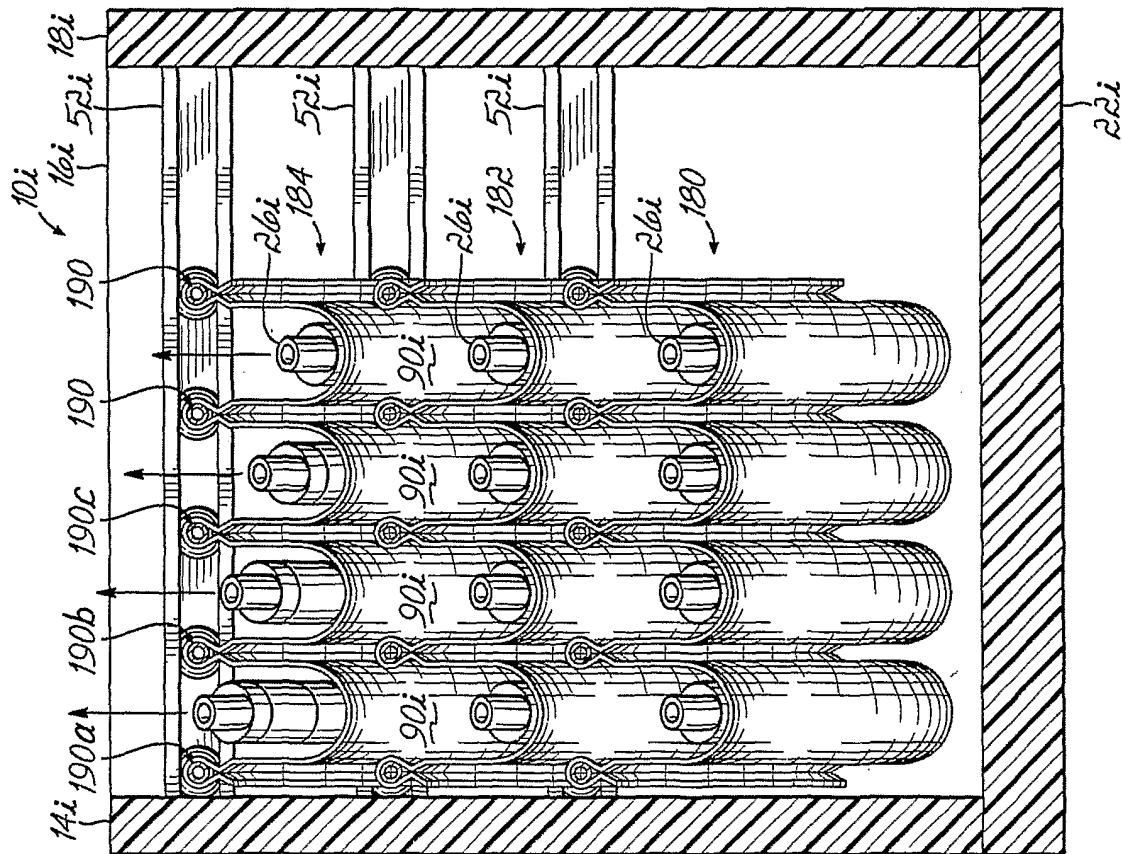

FIG. 24

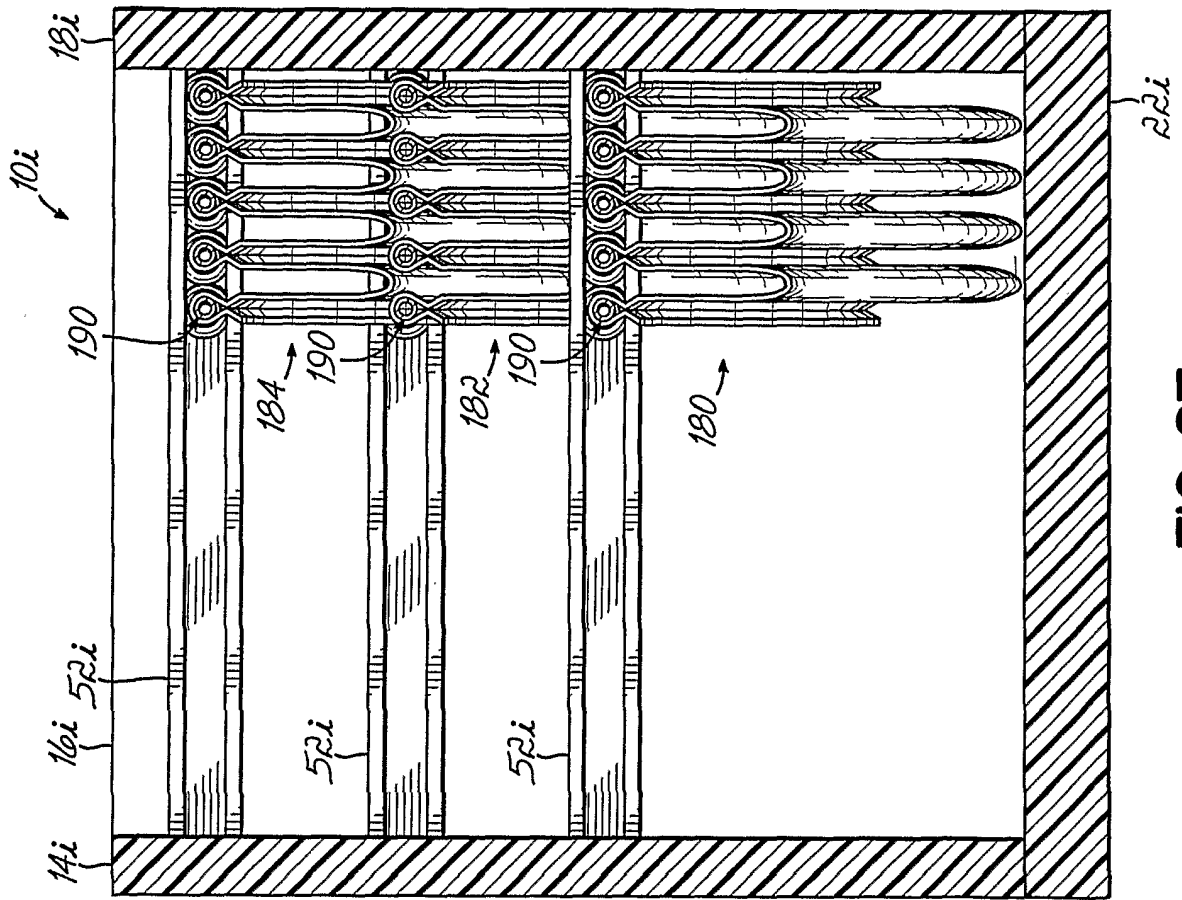

FIG. 27

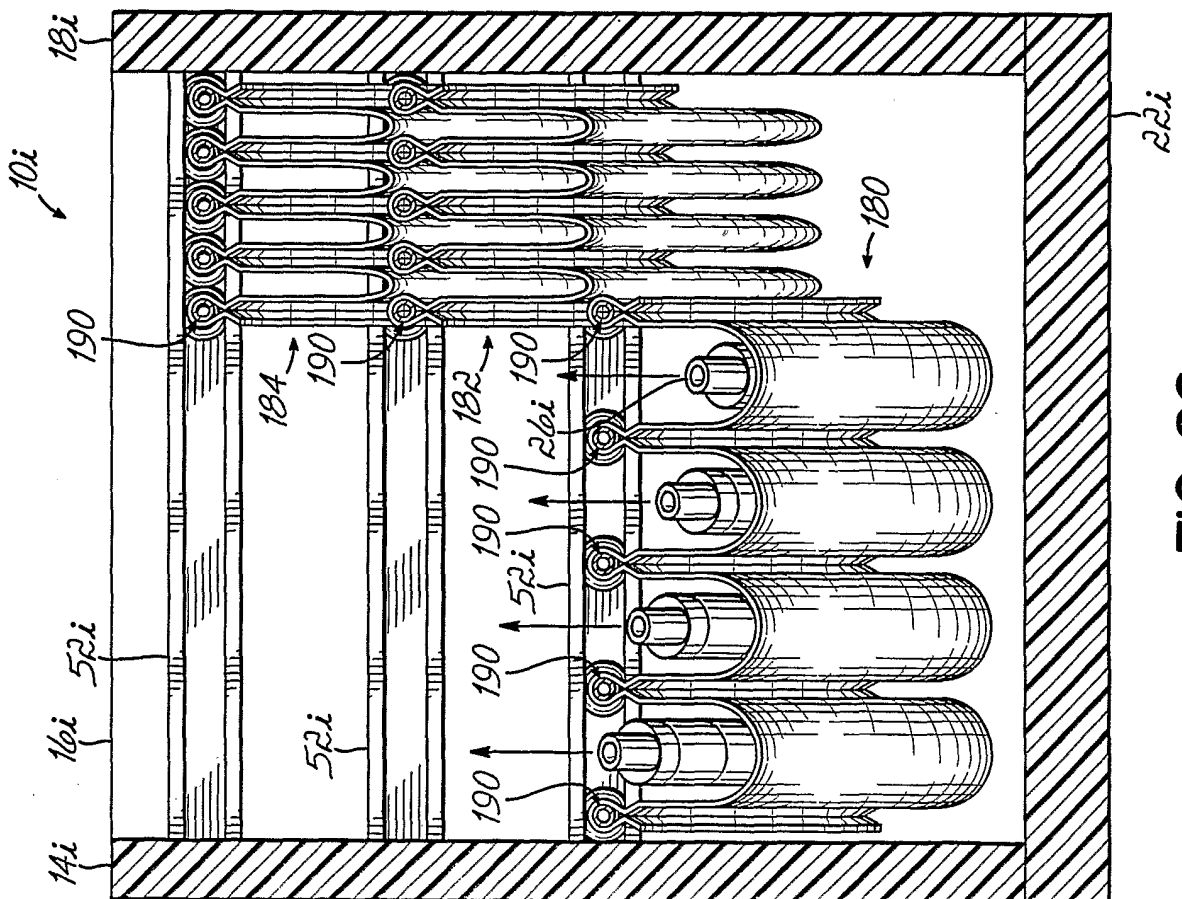

FIG. 26

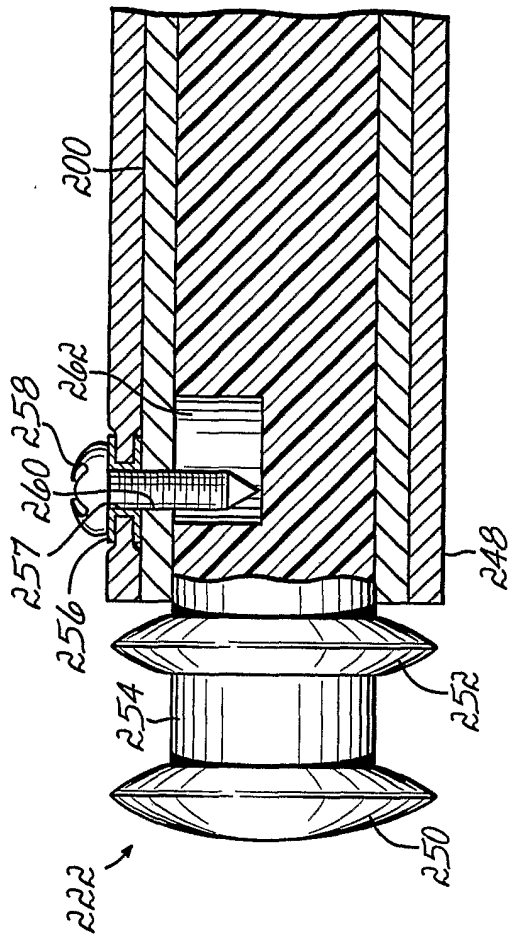

FIG. 29

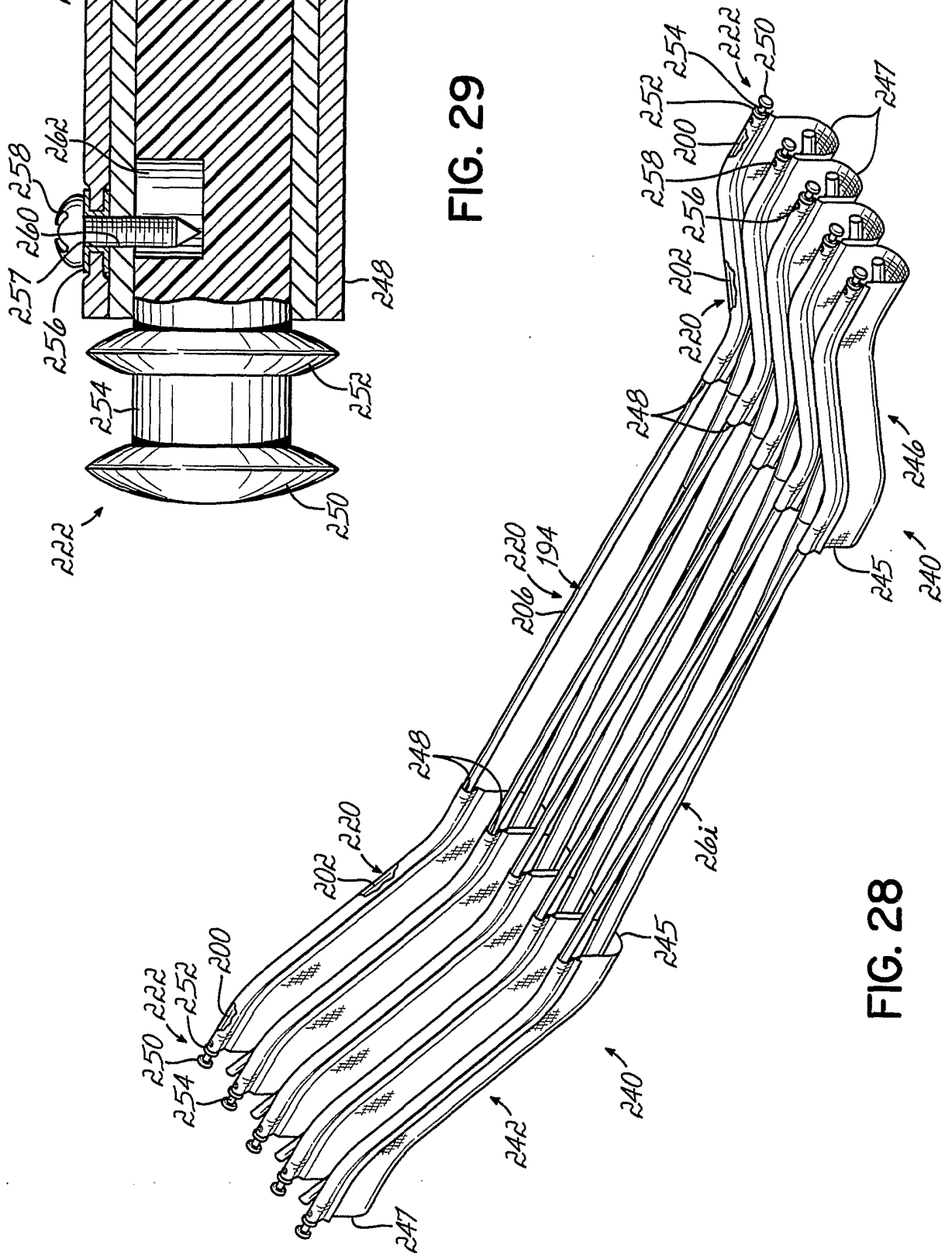

FIG. 28