

DANIEL WOODBURY.
Improvement in Horse-Powers.

No. 127,537.

Patented June 4, 1872.

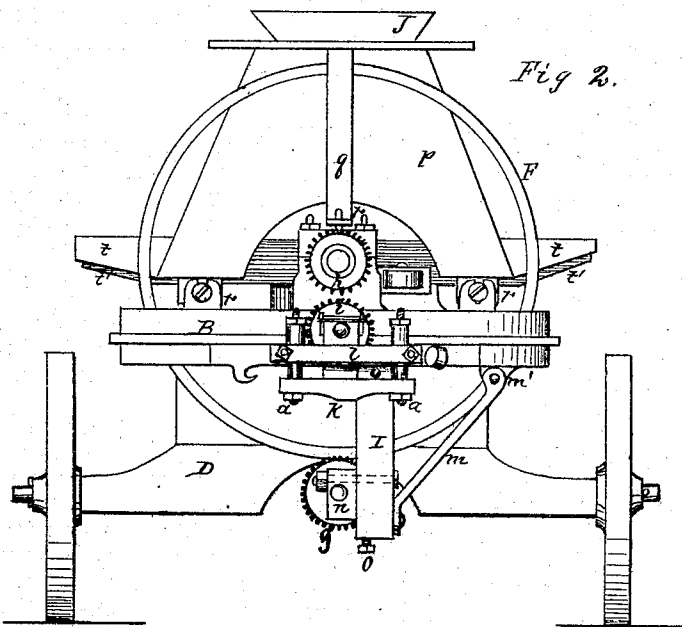
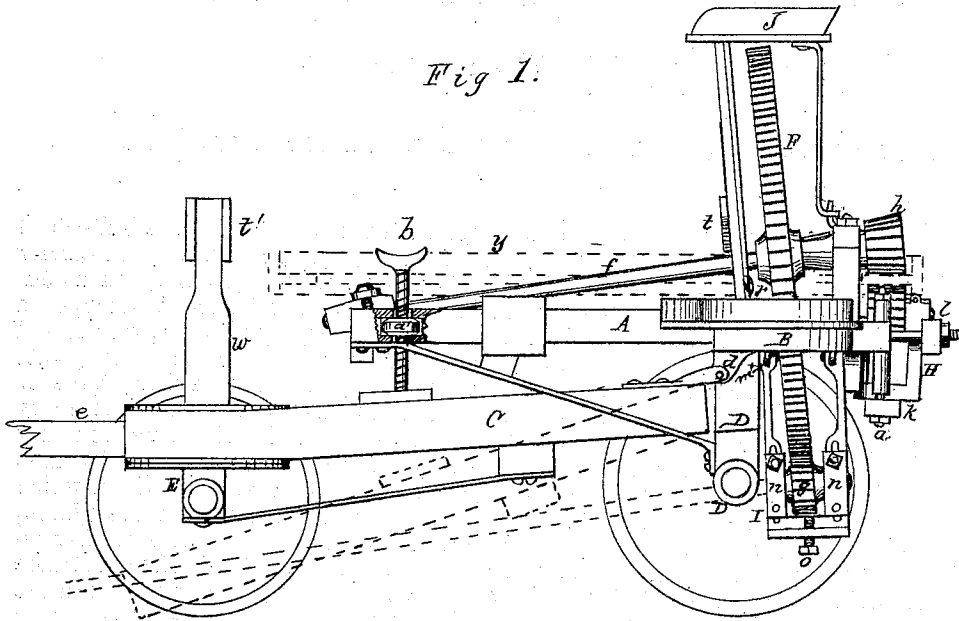

Witnesses:
J. M. Howe
J. C. Dietrich

Inventor:
Daniel Woodbury
by Wm. S. Searles

UNITED STATES PATENT OFFICE.

DANIEL WOODBURY, OF ROCHESTER, NEW YORK.

IMPROVEMENT IN HORSE-POWERS.

Specification forming part of Letters Patent No. 127,537, dated June 4, 1872.

SPECIFICATION.

Be it known that I, DANIEL WOODBURY, of Rochester, in the county of Monroe and State of New York, have invented certain Improvements in Horse-Powers, of which the following is a specification:

My invention relates to that class of machines known as "mounted" horse-powers, in which a self-centering "bull-wheel" is employed; and it consists more particularly in a peculiar method of attaching the boxes of the trucks which support the "bull-wheel," and in making the boxes of the "tumbling" or driving rod adjustable in such a manner as to admit the use of pinions of different sizes. It further consists in a certain construction and arrangement of the frame and connected parts by which the handling of the power is facilitated and strength and cheapness secured.

Figure 1 is a side elevation of my invention. Fig. 2 is a rear elevation of the same.

A and B represent the main frame or bed of my machine, composed partly of metal and partly of wood, and arranged similarly to that described in my patent of October 5, 1869. D is the main carrying-axle, to which the frame A B is rigidly attached. C is a draft-bar or frame, which is hinged, at *d*, to the frame A B, and supports the extremity of the latter by means of the screw *b*. I have shown the outer end of the frame C as being supported upon another carrying-axle, E, but this may be dispensed with, if desirable, and the frame allowed to rest on the ground or upon suitable blocking while in use, as indicated by dotted lines in Fig. 1. When two wheels only are used the extension *e* forms a carrying-bar for transportation, but when four wheels are used an ordinary tongue may be attached to the axle E. The screw *b* passes through a nut, *a*, upon the main frame A B, and rests upon the frame C, whereby said main frame may be brought to a horizontal position regardless of the inclination of the draft-frame. The nut *a* moves laterally in a recess in the frame, and its faces being somewhat curved it accommodates itself to any angle of the screw. The shaft *f* and its gear F are driven by the bull-wheel, indicated by the dotted lines *g* in Fig. 1, in the manner common to this class of powers; and the spur-wheel F, in turn, gears into the pin-

ion *g* upon the tumbling-rod. The bull-wheel is supported under the pinion *h* by the carrier pinion or truck *i*, having bearings in an adjustable frame, H. This frame rests upon a bridge-tree, *k*, preferably of wood; and it will be seen that if any substance accidentally gets into the teeth of the gears, either above or below, the bridge-tree will break before any of the other parts. This bridge-tree is easily replaced by the user of the power at any time. Another bridge-tree is also provided which receives the horizontal thrust of the pinion, in case of such accidents, with a similar result. The bridge-tree *k* is attached to the frame B by suitable bolts *a*, by means of which the frame H and pinion *i* may be adjusted to or from the bull-wheel to regulate the mesh of the teeth. The breakage of the teeth of the bull-wheel and pinions is sometimes quite likely to occur on account of obstructions, but by the above arrangement such breakage is confined to an inexpensive part of the machine, which is readily replaced. I is a hanger, which is suspended from the frame A B, and is constructed at the upper end to embrace lugs, *m'*, formed upon the metallic portion B of said frame. Braces *m* are also looped to the frame in a similar manner, and are suitably connected to the lower portion of the hanger, thus rigidly fixing the latter. Bolts or pins are put through the lugs upon the frame and the jaws embracing them, as at *m'*, Fig. 2.

By this method of attaching the hanger I obtain sufficient strength and rigidity, while at the same time the parts are very cheap in construction.

The boxes *n* of the pinion *g* are rigidly connected together, and may move vertically upon the hanger I, being clamped thereto by both passing through slots in the latter, and the adjustment controlled by a set-screw, *o*. By this means pinions of various sizes may be used upon the tumbling-rod or the degree of mesh of the teeth regulated at any time. The driver's seat J is supported upon uprights *p* and *q*, which rest in suitable sockets, *r*, upon the frame A B, so as to be readily removable therefrom. Lateral wings *t* are provided upon the upright *p*, upon which the "outrigs" and sweeps are placed for transportation; and

an upright, *w*, provided also with similar wings, *t'*, is attached to the forward part of the frame C for the same purpose. The upright *w* is likewise made readily detachable from the machine, and when but two carrying-wheels are used it may be placed under the extremity of the draw-frame C to support the forward part of the power when in use. The nest J also serves as a housing for the gear-wheel F.

What I claim as my invention is—

1. In combination with the adjustable frame H carrying the truck-pinion *i*, the bridge-trees *kl*, either or both, for the purposes set forth.

2. The connected boxes *u* of the pinion *g*, arranged to be adjusted vertically upon the hanger I, substantially as and for the purposes specified.

3. In combination with the main frame A B and hinged draft-frame C, the leveling-screw *b*, for the purposes set forth.

4. A mounted horse-power, embracing in its construction the detachable drivers' seat J, provided with lateral projections *t*, and the upright *w* provided with similar projections, *t'*, for the purposes set forth.

5. A horse-power, embracing in its construction the vertical hanger I looped to lugs upon the frame B, and the braces *m* similarly attached to the frame, all arranged to support the tumbling-rod and boxes, as herein set forth.

DANIEL WOODBURY.

Witnesses:

THOS. B. HUGHES,
JAMES SCANLON.