

(19) World Intellectual Property  
Organization  
International Bureau



(43) International Publication Date  
24 June 2004 (24.06.2004)

PCT

(10) International Publication Number  
**WO 2004/053257 A1**

(51) International Patent Classification<sup>7</sup>: **E04F 15/02**,  
15/04, B27G 11/00

(21) International Application Number:  
PCT/SE2003/001834

(22) International Filing Date:  
27 November 2003 (27.11.2003)

(25) Filing Language: English

(26) Publication Language: English

(30) Priority Data:  
0203631-7 9 December 2002 (09.12.2002) SE

(71) Applicant: **PERGO(EUROPE) AB** [SE/SE]; Strandri-  
daregatan 8, S-231 25 Trelleborg (SE).

(72) Inventors: **SJÖBERG, Åke**; Kyrkoled 8, S-227 31 Lund  
(SE). **KORNFÄLT, Sven**; Månstorpsgatan 9, S-216 20  
Malmö (SE).

(74) Agent: **STENBERG, Yngve**; c/o Perstorp AB, S-284 80  
Perstorp (SE).

(81) Designated States (*national*): AE, AG, AL, AM, AT, AU,  
AZ, BA, BB, BG, BR, BW, BY, BZ, CA, CH, CN, CO, CR,  
CU, CZ, DE, DK, DM, DZ, EC, EE, ES, FI, GB, GD, GE,  
GH, GM, HR, HU, ID, IL, IN, IS, JP, KE, KG, KP, KR,  
KZ, LC, LK, LR, LS, LT, LU, LV, MA, MD, MG, MK,  
MN, MW, MX, MZ, NI, NO, NZ, OM, PG, PH, PL, PT,  
RO, RU, SC, SD, SE, SG, SK, SL, SY, TJ, TM, TN, TR,  
TT, TZ, UA, UG, UZ, VC, VN, YU, ZA, ZM, ZW.

(84) Designated States (*regional*): ARIPO patent (BW, GH,  
GM, KE, LS, MW, MZ, SD, SL, SZ, TZ, UG, ZM, ZW),  
Eurasian patent (AM, AZ, BY, KG, KZ, MD, RU, TJ, TM),  
European patent (AT, BE, BG, CH, CY, CZ, DE, DK, EE,  
ES, FI, FR, GB, GR, HU, IE, IT, LU, MC, NL, PT, RO, SE,  
SI, SK, TR), OAPI patent (BF, BJ, CF, CG, CI, CM, GA,  
GN, GQ, GW, ML, MR, NE, SN, TD, TG).

**Published:**  
— with international search report

For two-letter codes and other abbreviations, refer to the "Guid-  
ance Notes on Codes and Abbreviations" appearing at the begin-  
ning of each regular issue of the PCT Gazette.

(54) Title: A PROCESS FOR SEALING OF A JOINT

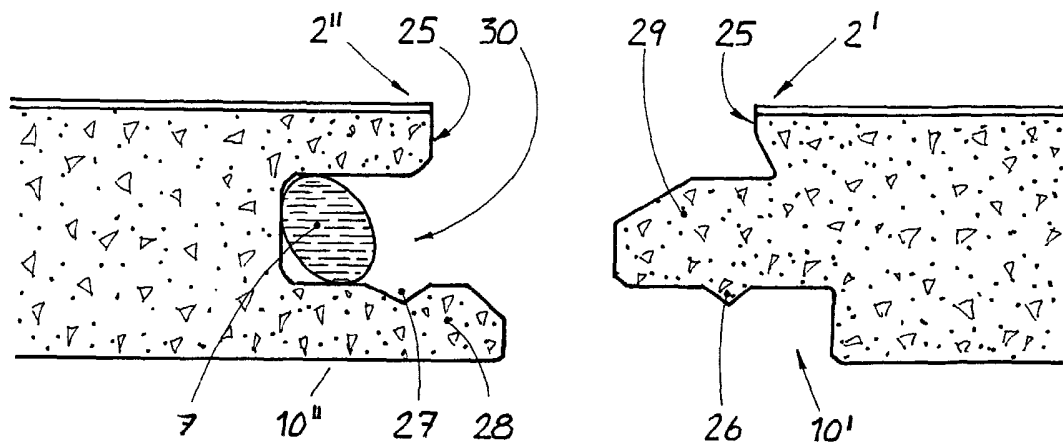

(57) Abstract: Means for installation of panels, the panels comprising a core, a decorative upper surface and edges provided with joining means for positioning the panels towards one another. Predetermined portions of the edges are provided with an encapsulated agent which is made present on the edges of the surface elements before assembly and which encapsulation is ruptured by means of assembly making the agent available to the core. The surface elements are hereby joined to one another by use of the joining means wherein a unit of a plurality of surface elements is formed.

WO 2004/053257 A1

**A process for sealing of a joint.**

The present invention relates to sealing of a joint comprising glued edges.

Prefabricated surface elements which at their edges are provided with groove and tenon are well known nowadays. As these are very easy to install, it is possible for the normal handy man to achieve this. Such elements can be constituted of massive wood, fibre board or particle board. These are often provided with a surface layer, such as lacquer or some sort of laminate. The boards are most often installed by gluing them together via their groove and tenon. It is desired to join the separate elements so closely that the joint becomes practically invisible, which increases the moisture resistance radically. The usable life of the installed elements are hereby also increased. It is essential that glue is used excessively in order to achieve a tight joint. Any gaps will make it possible for moisture to penetrate the joint with subsequent swelling of the core material closest to the joint. The glue also have to be used to an amount that it is spill out trough the joint on the decorative side of the surface elements. The superfluous glue will of course have to be wiped off before beginning to set, which is very time consuming.

One way of solving the problem is available on the market for some time now through different types of so-called click or snap-lock floor boards where no glue is to be used. The installation of such floor boards has become much swifter as no glue is required. The problems with these type of surface elements are that relatively small spills of fluids like water may cause great damage on the installed surface elements as well as sub walls and especially subfloors as the fluid will run through the joints rather rapidly due to the capillary effect. It is, of course, possible to use glue on these snap-lock type of elements as well although the problem with the time consuming cleaning during installation would remain.

It has, through the present invention, been made possible to solve the above mentioned problems so that self sealing surface elements can be achieved. The glue system can be used on any type of joint but have its greatest advantage on panels provided with tongue and grove along its edges. The glue system is

advantageously used on joints with mechanical locking since a snap-action locking will ensure a proper positioning with radically decreased risk for undesired gaps in the joint. Accordingly the invention relates to a means for installation of panels. The panels comprises a core, a decorative upper surface and edges provided with joining means for positioning the panels towards one another. The invention is characterised in that predetermined portions of the edges are provided with an encapsulated agent which is made present on the edges of the surface elements before assembly and which encapsulation is ruptured by means of the assembly making the agent available to the core. The panels are hereby joined to each other by use of the joining means wherein a unit of a plurality of surface elements is formed.

According to one embodiment of the invention the encapsulated agent is present in the form of at least one tube containing the agent. Such a tube is then preferably sealed in its ends, thereby preventing the agent to leak.

According to a preferred embodiment of the invention the tube is sectioned into a series of confined bodies of agent. This will ensure that enough of the agent is present to ensure a good bond when cutting panels during installation, as such cutting, inevitably will rupture the tube. Since the tube is sectioned, only one or at most two of the confined bodies of agent will be ruptured, leaving enough of the confined bodies of agent to ensure a good bond. The most important reason to have the tube sectioned into confined bodies of agent is however the importance of even distribution of the agent along the joint. If, for example, a single compartment tube were to be used and the joint were assembled slowly, it would be possible that a full amount of the agent would leak out at one of its ends. This is, of course not desired. It is therefore advantageous to use a tube which is sectioned. It is also advantageous to design the tube in a way that it will rupture in a controlled manner during assembly. This is best performed by making the tube of a strip material, most suitably a thermoplastic laminate. The materials of the laminate are selected so that the longitudinal bond of the tube breaks before the latitudinal bond. It will hereby be secured that each body of agent will rupture during assembly. One way of achieving this is by making the tube welded from a thermoplastic laminate strip where the long sides of the strip is overlapping so that an inside of the strip is welded towards an outside of the opposite long side of the

strip thereby forming the tube. The material of the laminate is selected so that the inside is constituted of a first material and the outside is constituted by a second material wherein the first material will have a good bond when welded together with itself and wherein a second material have a bond to the first material which is weaker than the bond between two first materials.

The encapsulated agent may according to one embodiment of the invention be a glue, suitably of the PVAC glue type or a polyurethane glue type. The encapsulated agent may alternatively be a solvent used as an activator. A glue is then pre-applied on the edges as an emulsion which then is allowed to dry before the joining of the surface elements, whereby the agent is a solvent used for activating the dry glue during assembly. Both the pre-applied dry glue and the tube containing the agent is advantageously applied during manufacturing to make the final assembly easier. The pre-applied dry glue is suitably a PVAC glue whereby the agent is water or a mixture of water and alcohol. The glue may further comprise an expanding agent causing the glue to swell when activated. This will ensure that the glue is distributed over desired surfaces of the joint. Such an expanding agent may be a cellulose derivative. It is also possible to an expanding agent which reacts with water or alcohol like for example calcium hydro carbonate or sodium hydro carbonate. This will cause the glue to foam.

According to an alternative embodiment of the invention the agent is encapsulated glue which is present in the form of pairs of tubes where a first tube contains a first glue component of a two component glue system and where a second tube contains a second component of the two component glue system. Also here the tubes are preferably at least sealed in the ends. It is however most advantageous to have the tubes sectioned into a series of confined bodies of glue of reasons as discussed above.

The joining means of the panel according to the present invention are suitably arranged so that a first edge of the panel is provided with a groove while a second edge, arranged parallel to the first edge and opposite thereto, is provided with a tongue. The encapsulated agent is suitably applied in a recess in the groove. The

encapsulated agent is alternatively applied in a recess on the tongue, suitably on an upper portion of the tongue. The joining means suitably comprises snapping wedges and recesses arranged to position and mechanically lock the panels tightly together while the glue sets. Also remaining edges of the panel is advantageously provided joining means and an encapsulated agent like described above.

According to an alternative embodiment of the invention the encapsulated agent is present in the form of a plurality of spheres containing the agent. The spheres may contain a glue or a solvent used for activating pre-applied glue as previously discussed in connection to the tube shaped encapsulation. Also here the encapsulated agent may be a glue contained in pairs of spheres where a first amount of spheres contains a first glue component of a two component glue system and where a second amount of spheres contains a second component of the two component glue system. The material used for making the spheres may be glass or a thermoplastic material, taking in consideration that it should be easily ruptured and be able to prevent the contents from migrating through the walls of the encapsulation for at least 3 months.

The invention is described further in connection to enclosed figures showing different embodiments of the invention whereby,

-figure 1 shows a first embodiment of adjacent edges of two panels to be joined according to the present invention.

-figure 2 shows a second embodiment of adjacent edges of two panels to be joined according to the present invention.

-figure 3 shows a third embodiment of adjacent edges of two panels to be joined according to the present invention.

-figure 4 shows a fourth embodiment of adjacent edges of two panels to be joined according to the present invention.

-figure 5 shows a fifth embodiment of adjacent edges of two panels to be joined according to the present invention.

-figure 6 shows a tube sectioned into a series of encapsulating confined bodies of agent.

Figure 1 shows, in cross-section, two adjacent edges according to a first embodiment of the invention. The panels 1 are provided with a first assembly joining member  $10^I$  on a first edge  $2^I$  while a second edge  $2^{II}$  is provided with a second assembly joining member  $10^{II}$ . The second edge  $2^{II}$  is arranged on a side opposite to the first edge  $2^I$ . The first assembly joining member  $10^I$  is provided with a lower snapping web 26 arranged on the lower side of a tongue. The lower snapping web 26 is intended to interact with a recess 27 arranged on a lower cheek 28 arranged on the second vertical assembly joining members  $10^{II}$  so that two joined adjacent panels 1 are locked against each other in a horizontal direction. The lower cheek 28 forms a lower surface of a groove 30 in the second edge  $2^{II}$ .

The joint between a first and a second edge  $2^I$  and  $2^{II}$  respectively of two joined panels 1 further comprises contact surfaces which are constituted by the lower snapping web 26 and recess 27, the tongue 29 and groove 30 as well as upper mating surfaces 25. The joint between two joined panels 1 also comprises cavities which are formed between the surfaces of the assembled joint. One such cavity is arranged between the upper mating surface 25 and the tongue 29 of the first assembly joining member  $10^I$ . One special cavity is formed in the bottom of the groove 30 and is designed for holding a tube of encapsulated PVAC glue. The special cavity as well as the tip of the tongue 29, being closest to the special cavity when assembled, is designed to rupture the tube of encapsulated glue 7 and force the glue towards the upper mating surfaces 25. The later may be further secured by having applied a foaming agent on the surface of the special cavity, or by using a polyurethane glue. The tip of the tongue 29 is further provided with an angled upper surface intended to guide the glue to the upper portions of the joint.

Figure 2 shows, in cross-section, two adjacent edges according to a second embodiment of the invention. The panels 1 are provided with a first assembly

joining member  $10^I$  on a first edge  $2^I$  while a second edge  $2^{II}$  is provided with a second assembly joining member  $10^{II}$ . The second edge  $2^{II}$  is arranged on a side opposite to the first edge  $2^I$ . The first assembly joining member  $10^I$  is provided with a lower snapping web 26 arranged on the lower side of a tongue 29. The lower snapping web 26 is intended to interact with a recess 27 arranged on a lower cheek 28 arranged on the second vertical assembly joining members  $10^{II}$  so that two joined adjacent panels 1 are locked against each other in a horizontal direction. The lower cheek 28 forms a lower surface of a groove 30 in the second edge  $2^{II}$ .

The joint between a first and a second edge  $2^I$  and  $2^{II}$  respectively of two joined panels 1 further comprises contact surfaces which are constituted by the lower snapping web 26 and recess 27, the tongue 29 and groove 30 as well as upper mating surfaces 25. The joint between two joined panels 1 also comprises cavities which are formed between the surfaces of the assembled joint. One special cavity is formed between the upper mating surface 25 and the tongue 29 of the first assembly joining member  $10^I$  and is designed for holding a tube of encapsulated PVAC glue. The special cavity as well as the opposite edge mating surface 25, being closest to the special cavity when assembled, is designed to rupture the tube of encapsulated glue 7. It is possible to further secure distribution of the glue by having applied a foaming agent on the surface of the special cavity, or by using a polyurethane glue with foaming agent. The tip of the tongue 29 is further provided with an angled upper surface intended to guide the glue to the upper portions of the joint.

Figure 3 shows, in cross-section, two adjacent edges according to a third embodiment of the invention. The panels 1 are provided with a first vertical assembly joining member  $10^I$  on a first edge  $2^I$  while a second edge  $2^{II}$  is provided with a second vertical assembly joining member  $10^{II}$ . The second edge  $2^{II}$  is arranged on a side opposite to the first edge  $2^I$ . The first vertical assembly joining member  $10^I$  is provided with mainly vertical lower cheek surfaces 21 arranged parallel to the closest edge 2. The lower cheek surfaces 21 are intended to interact with mainly vertical upper cheek surfaces 22 arranged on the second vertical assembly joining members  $10^{II}$  so that two joined adjacent panels 1 are locked

against each other in a horizontal direction. The first vertical assembly joining member  $10^I$  is moreover provided with a snapping hook 23 while the second vertical assembly joining member  $10^{II}$  is provided with a matching undercut 24, which by being provided with mainly horizontal locking surfaces limits the vertical movement between two joined adjacent panels 1.

The joint between a first and a second edge  $2^I$  and  $2^{II}$  respectively of two joined panels 1 further comprises contact surfaces which are constituted by the locking surfaces of the under cuts 23 and hooks 24, the mainly vertical upper cheek surfaces 22, lower cheek surfaces 21 as well as upper mating surfaces 25. The joint between two joined panels 1 also comprises cavities which are formed between the surfaces of the assembled joint. One special cavity is designed for holding a tube of encapsulated PVAC glue 7 is arranged below the under cut 23. The special cavity as well as the portion of the opposite edge 2 being closest to the special cavity when assembled, is designed to rupture the tube of encapsulated glue 7 and force the glue towards the upper mating surfaces 25. The later may be further secured by having applied a foaming agent on the surface of the special cavity, or by using a polyurethane glue.

Figure 4 shows, in cross-section, two adjacent edges according to a fourth embodiment of the invention. The panels 1 are provided with a first assembly joining member  $10^I$  on a first edge  $2^I$  while a second edge  $2^{II}$  is provided with a second assembly joining member  $10^{II}$ . The second edge  $2^{II}$  is arranged on a side opposite to the first edge  $2^I$ . The first assembly joining member  $10^I$  is provided with a lower snapping web 26 arranged on the lower side of a tongue 29. The lower snapping web 26 is intended to interact with a recess 27 arranged on a lower cheek 28 arranged on the second vertical assembly joining members  $10^{II}$  so that two joined adjacent panels 1 are locked against each other in a horizontal direction. The lower cheek 28 forms a lower surface of a groove 30 in the second edge  $2^{II}$ .

The joint between a first and a second edge  $2^I$  and  $2^{II}$  respectively of two joined panels 1 further comprises contact surfaces which are constituted by the lower snapping web 26 and recess 27, the tongue 29 and groove 30 as well as upper mating surfaces 25. The joint between two joined panels 1 also comprises cavities



which are formed between the surfaces of the assembled joint. One special cavity is arranged between the upper mating surface 25 and the tongue 29 of the first assembly joining member 10<sup>I</sup> and is designed for holding a tube of encapsulated PVAC glue. Another special cavity is formed in the bottom of the groove 30 and also designed for holding a tube of encapsulated PVAC glue. The special cavities as well as the tip of the tongue 29 and the upper mating surface 25 of the second vertical assembly member 10<sup>II</sup>, being closest to the special cavities when assembled, is designed to rupture the tubes of encapsulated glue 7 and force the glue towards the upper mating surfaces 25. The later may be further secured by having applied a foaming agent on the surface of the special cavity, or by using a polyurethane glue.

Figure 5 shows, in cross-section, two adjacent edges according to a fifth embodiment of the invention. The panels 1 are provided with a first assembly joining member 10<sup>I</sup> on a first edge 2<sup>I</sup> while a second edge 2<sup>II</sup> is provided with a second assembly joining member 10<sup>II</sup>. The second edge 2<sup>II</sup> is arranged on a side opposite to the first edge 2<sup>I</sup>. The first assembly joining member 10<sup>I</sup> is provided with an upper snapping web 26<sup>I</sup> arranged on the upper side of a tongue 29. The upper snapping web 26<sup>I</sup> is intended to interact with a recess 27 arranged on an upper cheek 28<sup>I</sup> arranged on the second vertical assembly joining members 10<sup>II</sup> so that two joined adjacent panels 1 are locked against each other in a horizontal direction. The upper cheek 28<sup>I</sup> forms an upper surface of a groove 30 in the second edge 2<sup>II</sup>.

The joint between a first and a second edge 2<sup>I</sup> and 2<sup>II</sup> respectively of two joined panels 1 further comprises contact surfaces which are constituted by the upper snapping web 26<sup>I</sup> and recess 27, the tongue 29 and groove 30 as well as upper mating surfaces 25. The joint between two joined panels 1 also comprises cavities which are formed between the surfaces of the assembled joint. One special cavity is formed between the upper mating surface 25 and the tongue 29 of the first assembly joining member 10<sup>I</sup> and is designed for holding a tube of encapsulated PVAC glue. The special cavity as well as the opposite edge mating surface 25, being closest to the special cavity when assembled, is designed to rupture the tube of encapsulated glue 7. It is possible to further secure distribution of the

glue by having applied a foaming agent on the surface of the special cavity, or by using a polyurethane glue with foaming agent. The tip of the tongue 29 is further provided with an angled upper surface intended to guide the glue to the upper portions of the joint.

Figure 6 shows, schematically in perspective view a selected embodiment of a tube according to the invention. An encapsulated agent is present in the form of at least one tube 7 containing the agent. The tube 7 is sectioned into a series of confined bodies 7<sup>I</sup> of agent. This will ensure that enough of the agent is present to ensure a good bond when cutting panels 1 during installation, as such cutting, inevitably will rupture the tube 7. Since the tube 7 is sectioned, only one or at most two of the confined bodies 7<sup>I</sup> of agent will be ruptured, leaving enough of the confined bodies 7<sup>I</sup> of agent to ensure a good bond. The most important reason to have the tube 7 sectioned into confined bodies 7<sup>I</sup> of agent is however the importance of even distribution of the agent along the joint. If, for example, a single compartment tube 7 were to be used and the joint were assembled slowly, it would be possible that the full amount of the agent would leak out at one of its ends. This is, of course not desired. It is therefore advantageous to utilise a tube 7 which is sectioned. It is also advantageous to design the tube 7 in a way that it will rupture in a controlled manner during assembly. This is best performed by making the tube 7 of a strip material, most suitably a thermoplastic laminate. The materials of the laminate are selected so that the longitudinal bond of the tube 7 breaks before the latitudinal 7<sup>II</sup> bond. It will hereby be secured that each body 7<sup>I</sup> of agent will rupture during assembly. One way of achieving this is by making the tube 7 welded from a thermoplastic laminate strip where the long sides of the strip is overlapping so that an inside of the strip is welded towards an outside of the opposite long side of the strip thereby forming the tube 7. The material of the laminate is selected so that the inside is constituted of a first material and the outside is constituted by a second material wherein the first material will have a good bond when welded together with itself and wherein a second material have a bond to the first material which is weaker than the bond between two first materials.

The encapsulated agent may according to one embodiment of the invention be a glue, suitably of the PVAC glue type or a polyurethane glue type. The encapsulated agent may alternatively be a solvent used as an activator. A glue is then pre-applied on the edges as an emulsion which then is allowed to dry before the joining of the surface elements, whereby the agent is a solvent used for activating the dry glue during assembly. Both the pre-applied dry glue and the tube 7 containing the agent is advantageously applied during manufacturing to make the final assembly easier. The pre-applied dry glue is suitably a PVAC glue whereby the agent is water or a mixture of water and alcohol. The glue may further comprise an expanding agent causing the glue to swell when activated. This will ensure that the glue is distributed over desired surfaces of the joint. Such an expanding agent may be a cellulose derivative. It is also possible to an expanding agent which reacts with water or alcohol like for example calcium hydro carbonate or sodium hydro carbonate. This will cause the glue to foam.

the agent may according to an alternative embodiment of the invention be an encapsulated glue which is present in the form of pairs of tubes where a first tube 7 contains a first glue component of a two component glue system and where a second tube 7 contains a second component of the two component glue system. Also here the tubes 7 are preferably sectioned into a series of confined bodies 7<sup>1</sup> of glue of reasons as discussed above. It is also important that the two components are allowed to blend. It is therefore suitable to have them arranged in the same special cavity or in special cavities arranged close to one another.

When selecting material for the tube 7 as well as when selecting agent in the form of solvent one must take in consideration that the tube 7 should be easily ruptured and be able to prevent the contents from migrating through the walls of the encapsulation for at least 3 months.

The invention is not limited by the embodiments shown since these can be varied in different ways within the scope of the invention.

**CLAIMS**

1. Means for installation of panels, the panels comprising a core, a decorative upper surface and edges provided with joining means for positioning the panels towards one another wherein predetermined portions of the edges are provided with an encapsulated agent which is made present on the edges of the surface elements before assembly and which encapsulation is ruptured by means of assembly making the agent available to the core whereby the panels are joined to one another by use of the joining means wherein a unit of a plurality of surface elements is formed.
2. Means according to claim 1 wherein the encapsulated agent is present in the form of at least one tube containing the agent.
3. Means according to claim 1 wherein the encapsulated agent is present in the form of a plurality of spheres containing the agent.
4. Means according to claim 2 wherein the at least one tube is sealed in its ends.
5. Means according to claim 2 wherein the tube is sectioned into a series of confined bodies of agent.
6. Means according to claim 1 wherein the encapsulated agent is a glue.
7. Means according to claim 6 wherein the encapsulated glue is present in the form of pairs of tubes where a first tube contains a first glue component of a two component glue system and where a second tube contains a second component of the two component glue system.
8. Means according to claim 7 wherein the tubes are sealed in the ends.
9. Means according to claim 7 wherein the tubes are sectioned into a series of confined bodies of glue.

10. Means according to claim 3 wherein the encapsulated agent is a glue contained in pairs of spheres where a first amount of spheres contains a first glue component of a two component glue system and where a second amount of spheres contains a second component of the two component glue system.
11. Means according to claim 5 wherein the tube comprises a thermoplastic material whereby the sectioning is performed by locally welding the wall of the tube together at predetermined positions thereby forming the confined bodies of agent.
12. Means according to claim 9 wherein the tube comprises a thermoplastic material whereby the sectioning is performed by locally welding the wall of the tube together at predetermined positions thereby forming the confined bodies of glue.
13. Means according to claim 8, wherein the tube is welded from a thermoplastic laminate strip the long sides of the strip overlapping so that an inside of the strip is welded towards an outside of the opposite long side of the strip thereby forming the tube, the material of the laminate being selected so that the inside is constituted of a first material and the outside is constituted by a second material wherein the first material have a good bond when welded together with the first material and wherein a second material have a bond to the first material which is weaker than the bond between two first materials.
14. Means according to claim 13 wherein the tubes are sectioned into a series of confined bodies of agent.
15. Means according to claim 14 wherein the sectioning is performed by locally welding the inside of the tube together at predetermined positions thereby forming the confined bodies of agent.
16. Means according to claim 14 wherein the tube comprises a thermoplastic material whereby the sectioning is performed by locally welding the wall of the tube together at predetermined positions thereby forming confined bodies of agent in the form of glue.

17. Means according to claim 6 wherein the glue is a PVAC glue.
18. Means according to claim 6 wherein the glue is a polyurethane glue.
19. Means according to claim 1 wherein the joining means are arranged so that a first edge of the panel is provided with a groove while a second edge, arranged parallel to the first edge and opposite thereto, is provided with a tongue.
20. Means according to claim 19 wherein the encapsulated agent is applied in a recess in the groove.
21. Means according to claim 19 wherein the encapsulated agent is applied in a recess on the tongue.
22. Means according to claim 21 wherein the recess is arranged on an upper portion of the tongue.
23. Means according to claim 1 wherein a first portion of the encapsulated agent is arranged in a recess of the groove while a second portion of the encapsulated agent is arranged in a recess on the tongue.
24. Means according to claim 9 wherein the first tube is arranged in a recess of the groove while the second tube is arranged in a recess on the tongue.
25. Means according to claim 24 wherein the joining means comprises snapping wedges and recesses arranged to position and mechanically lock the panels tightly together while the glue sets.
26. Means according to claim 1 wherein a glue is applied on the edges as an emulsion which then is allowed to dry before the joining of the surface elements and that the agent is a solvent used for activating the dry glue during assembly.
27. Means according to claim 26 wherein the agent is water.
28. Means according to claim 26 wherein the agent is a mixture of water and alcohol.

29. Means according to claim 26 wherein the glue further comprises an expanding agent causing the glue to swell when activated.
30. Means according to claim 29 wherein the expanding agent is a cellulose derivative.
31. Means according to claim 29 wherein the expanding agent causes the glue to foam.

Fig. 1

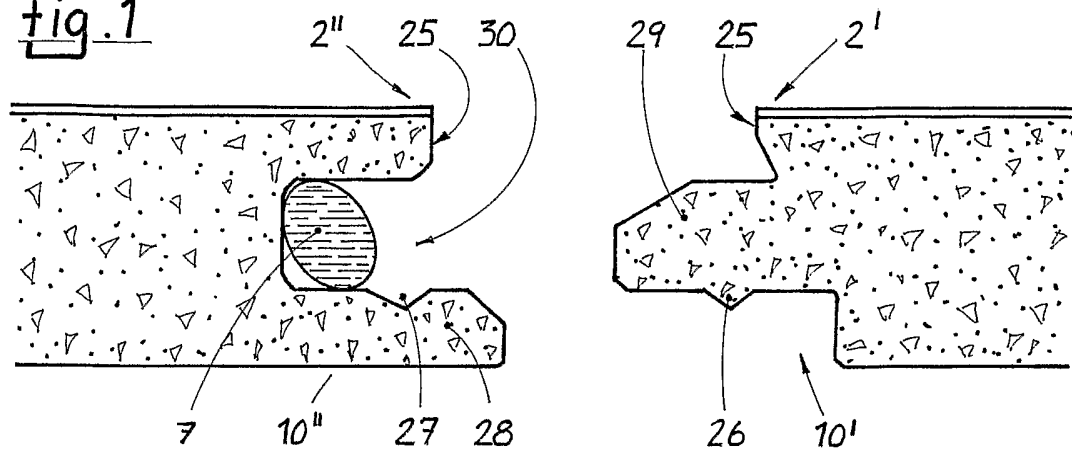

Fig. 2

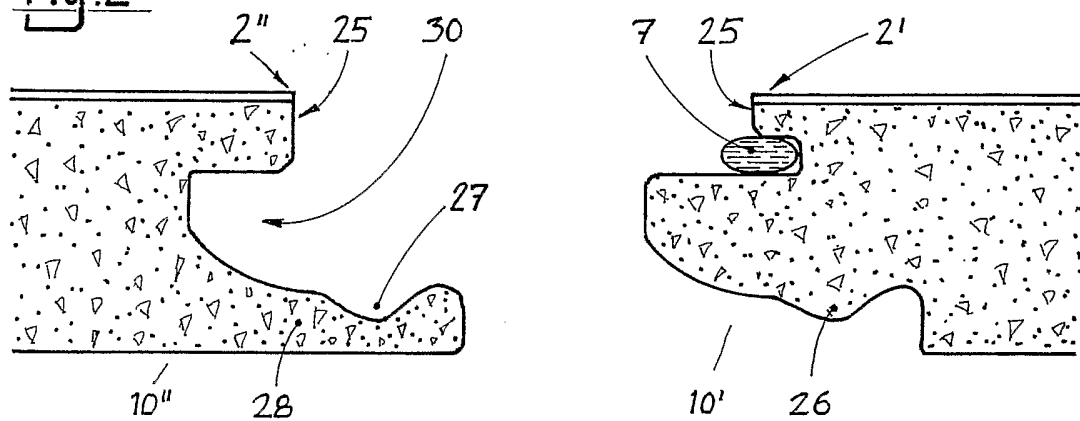

Fig. 3

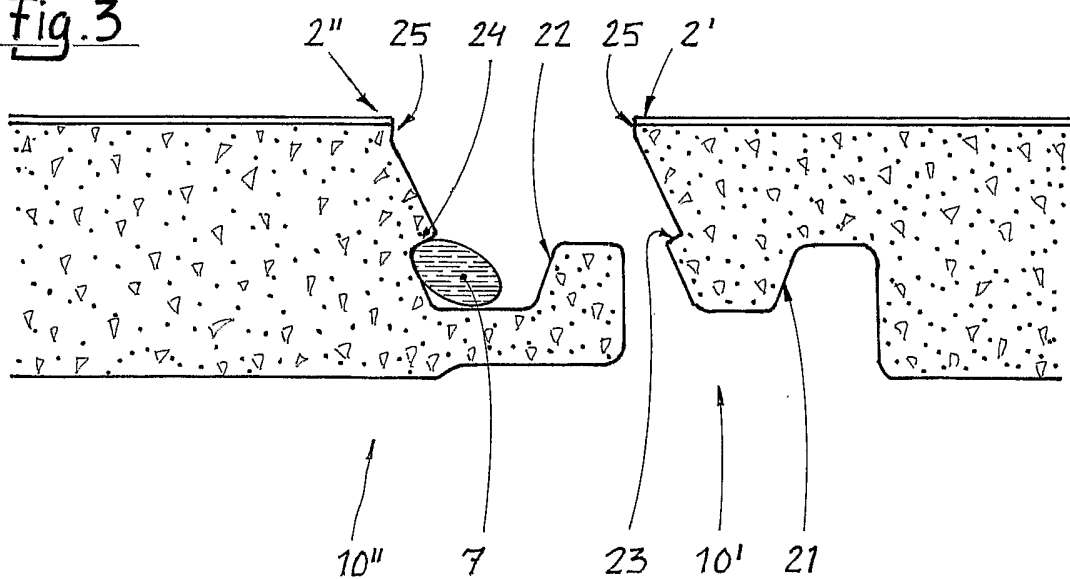



Fig. 4

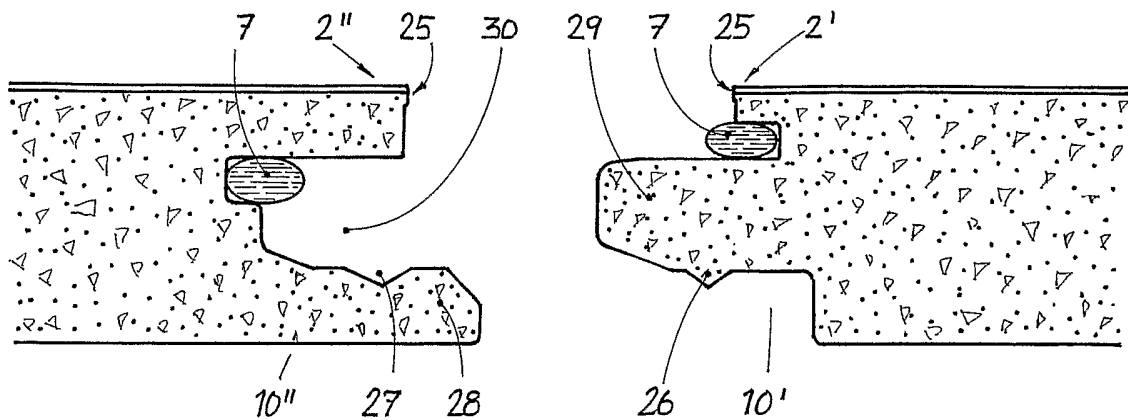

Fig. 5

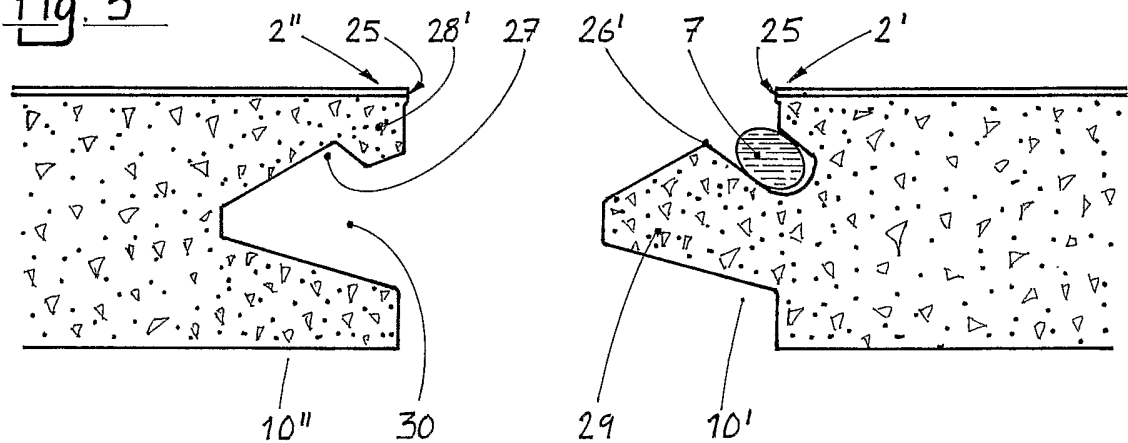
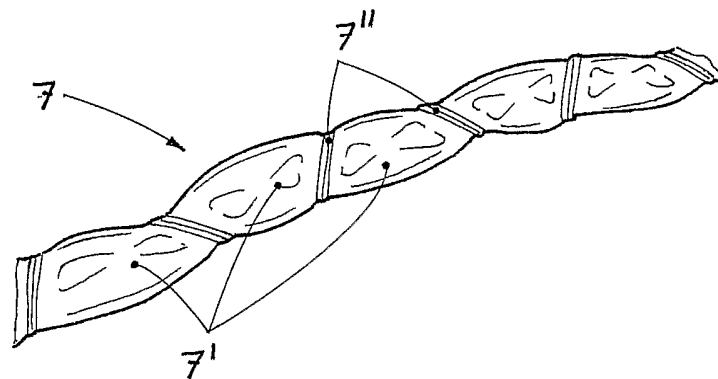

Fig. 6



## INTERNATIONAL SEARCH REPORT

International application No.

PCT/SE 2003/001834

<b>A. CLASSIFICATION OF SUBJECT MATTER</b>		
IPC7: E04F 15/02, E04F 15/04, B27G 11/00 According to International Patent Classification (IPC) or to both national classification and IPC		
<b>B. FIELDS SEARCHED</b>		
Minimum documentation searched (classification system followed by classification symbols)		
IPC7: E04F, B27G, E04B		
Documentation searched other than minimum documentation to the extent that such documents are included in the fields searched		
SE,DK,FI,NO classes as above		
Electronic data base consulted during the international search (name of data base and, where practicable, search terms used)		
EPO-INTERNAL, WPI DATA, PAJ		
<b>C. DOCUMENTS CONSIDERED TO BE RELEVANT</b>		
Category*	Citation of document, with indication, where appropriate, of the relevant passages	Relevant to claim No.
X	US 2002046526 A1 (F. KNAUSEDER), 25 April 2002 (25.04.2002), paragraph (0036) - paragraph (0039), paragraph (0045) - paragraph (0050), paragraph 0029); figures 1-4; claim 20	1-4,6-8,10, 17-23,26-31
A	--	5,9,11-16, 24-25
X	EP 1229181 A1 (FRITZ EGGER GMBH & CO.), 7 August 2002 (07.08.2002), figures 1-8, claims 1-10,15-17, abstract	1-4,6-8,10, 17-23,26-31
A	--	5,9,11-16, 24-25
<input checked="" type="checkbox"/> Further documents are listed in the continuation of Box C. <input checked="" type="checkbox"/> See patent family annex.		
* Special categories of cited documents: "A" document defining the general state of the art which is not considered to be of particular relevance "E" earlier application or patent but published on or after the international filing date "L" document which may throw doubts on priority claim(s) or which is cited to establish the publication date of another citation or other special reason (as specified) "O" document referring to an oral disclosure, use, exhibition or other means "P" document published prior to the international filing date but later than the priority date claimed "T" later document published after the international filing date or priority date and not in conflict with the application but cited to understand the principle or theory underlying the invention "X" document of particular relevance: the claimed invention cannot be considered novel or cannot be considered to involve an inventive step when the document is taken alone "Y" document of particular relevance: the claimed invention cannot be considered to involve an inventive step when the document is combined with one or more other such documents, such combination being obvious to a person skilled in the art "&" document member of the same patent family		
Date of the actual completion of the international search		Date of mailing of the international search report
4 February 2004		18-02-2004
Name and mailing address of the ISA/ Swedish Patent Office Box 5055, S-102 42 STOCKHOLM Facsimile No. +46 8 666 02 86		Authorized officer  Jörgen Klöfver / MRo Telephone No. +46 8 782 25 00

## INTERNATIONAL SEARCH REPORT

International application No.

PCT/SE 2003/001834

C (Continuation). DOCUMENTS CONSIDERED TO BE RELEVANT		
Category*	Citation of document, with indication, where appropriate, of the relevant passages	Relevant to claim No.
X	EP 1229182 A1 (FRITZ EGGER GMBH & CO.), 7 August 2002 (07.08.2002), claims 1-10, abstract	1-4,6-8,10, 17-23,26-31
A	--	5,9,11-16, 24-25
X	US 2002127374 A1 (M. SPRATLING), 12 Sept 2002 (12.09.2002), claims 1-7	1-4,6-8,10, 17-23
A	--	5,9,11-16, 24-31
A	DE 29703962 U1 (WITEX AG), 5 June 1997 (05.06.1997)	1-31
	-- -----	

## INTERNATIONAL SEARCH REPORT

Information on patent family members

International application No.

24/12/2003

PCT/SE 2003/001834

US	2002046526	A1	25/04/2002	AT	9922000	A	15/05/2003
				AU	6905001	A	17/12/2001
				AU	7372801	A	17/12/2001
				BR	0111435	A	10/06/2003
				CA	2380115	A	13/12/2001
				CA	2411433	A	05/12/2002
				CN	1380926	T	20/11/2002
				CZ	20024009	A	18/06/2003
				EP	1287219	A	05/03/2003
				EP	1294996	A	26/03/2003
				HU	0301467	A	28/11/2003
				IL	147849	D	00/00/0000
				SI	21105	A	30/06/2003
				SK	17202002	A	11/09/2003
				TR	200200324	T	00/00/0000
				US	2002148551	A	17/10/2002
				WO	0194720	A	13/12/2001
				WO	0194721	A	13/12/2001
-----							
EP	1229181	A1	07/08/2002	US	2002189747	A	19/12/2002
				WO	02063114	A	15/08/2002
-----							
EP	1229182	A1	07/08/2002	AT	239156	T	15/05/2003
				DE	50100214	D	00/00/0000
-----							
US	2002127374	A1	12/09/2002	AU	9696301	A	15/04/2002
				WO	0229179	A	11/04/2002
-----							
DE	29703962	U1	05/06/1997	NONE			
-----							