

M. GORE.
FEED GRINDER.

No. 111,530.

Patented Feb. 7, 1871.

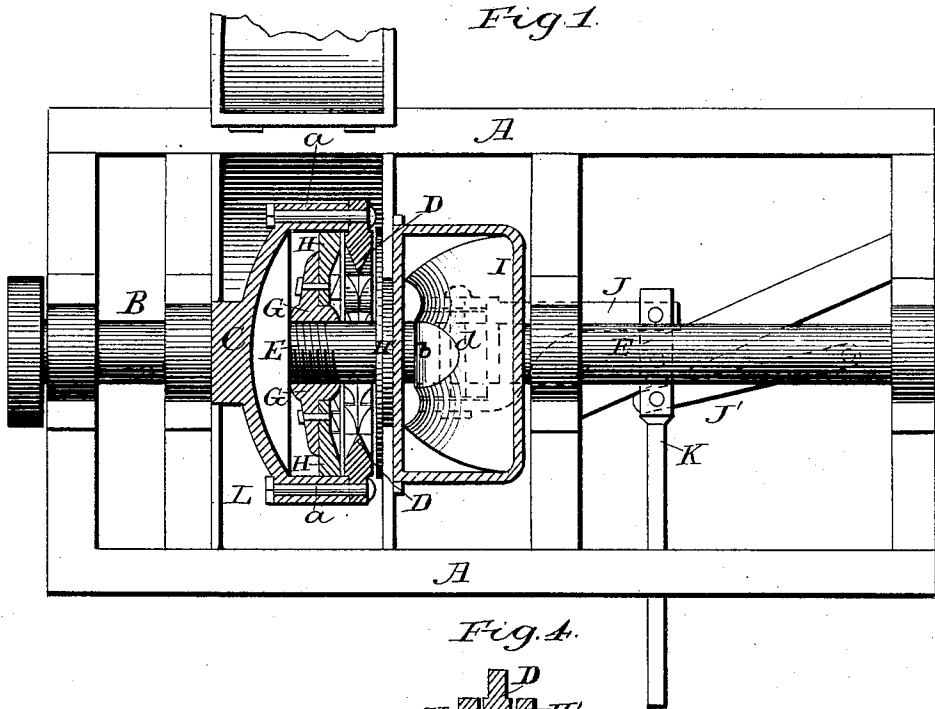

Fig. 1.

Fig. 3.

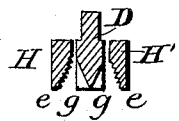
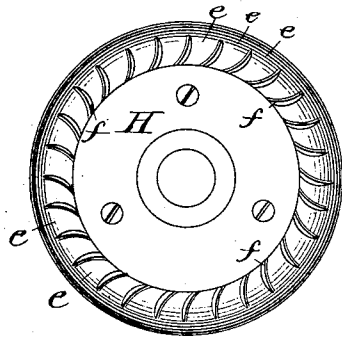
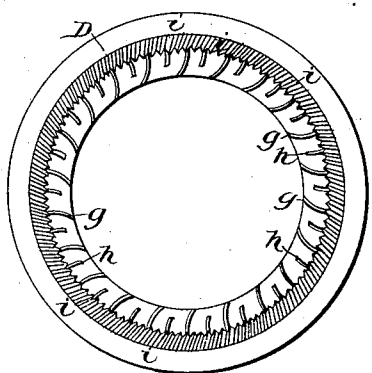

Fig. 4.

Fig. 2.



Witnesses:

A. A. Yeatman,
C. L. Quest,

Inventor:

Myron Gore
per Alexander Mason

Attys.

United States Patent Office.

MYRON GORE, OF OTTAWA, ILLINOIS.

Letters Patent No. 111,530, dated February 7, 1871.

IMPROVEMENT IN FEED-GRINDERS.

The Schedule referred to in these Letters Patent and making part of the same.

To all whom it may concern:

Be it known that I, MYRON GORE, of Ottawa, in the county of La Salle and in the State of Illinois, have invented certain new and useful Improvements in Feed-Grinders; and do hereby declare that the following is a full, clear, and exact description thereof, reference being had to the accompanying drawing and to the letters of reference marked thereon making a part of this specification.

The nature of my invention consists in the construction and arrangement of a "feed-grinder," as will be hereinafter fully set forth.

In order to enable others skilled in the art to which my invention appertains to make and use the same, I will now proceed to describe its construction and operation, referring to the annexed drawing, in which—

Figure 1 is a plan view of my machine, part of the same being in horizontal section;

Figure 2 is a side view of the rotating ring; and

Figure 3 is a side view of one of the stationary rings.

Figure 4 is a cross-section through the three grinding-rings.

A represents the frame of my machine, upon which, in suitable journal-boxes at one end, is a revolving shaft, B, provided at its inner end with the head C.

This head is provided with three or more arms, *a a*, projecting inward, to the ends of which the running ring D is secured by bolts and nuts or other suitable means, leaving a convenient space between the head C and said running ring.

In suitable bearings, on the frame A, is also placed an arbor, E, on a line with the shaft B.

On the inner end of this arbor is attached the head G, to which the ring H is bolted or otherwise secured.

This head and ring are so arranged as to be within the arms *a a* of the head C, and between said head and the ring D.

I is the hopper, to which is bolted or otherwise secured, another ring, H', which faces the opposite side of the revolving ring D.

The hopper I is provided near its lower end with a hub, *b*, which is nicely fitted to the shaft or arbor E.

A pin, *d*, passes through said hub and a horizontal slot in the arbor, preventing the hopper, with its ring, from turning on the arbor, but allowing it to slide back and forth for a short distance.

The pin *d* also passes through the forked end of an arm, J, the other end of which is pivoted to a lever, K, said lever being pivoted in the frame A.

To the lever K is also pivoted another arm, J', which, by a pin, is connected with the arbor or shaft E.

The points where the arms J J' are pivoted to the lever K should be one on each side, and the same

distance from the point where the lever itself is pivoted.

It will be seen that the ring D revolves between the rings H H', and remains in the same place constantly, while the rings H H', although not revolving, whence I have called them stationary, are movable to or from the revolving ring D.

The motion of these two rings, by means of the arrangement of the lever K and arms J J', is such that they will always be the same distance from the center or revolving ring D, whether such distance be large or small.

The entire grinding mechanism is inclosed in a casing, L, of which the hopper I forms a part, and said casing provided with a suitable outlet-spout.

The stationary rings H H' are dressed with circular grooves *e e* and curved ribs *f f*, as shown in fig. 3.

This dressing is made so shallow that corn or grain cannot get back far enough to be out of the way of the ribs on the running ring.

The running ring D, which is cut alike on both sides, is dressed with a smooth surface with curved ribs *g* and *h*, alternating of unequal length, as shown in fig. 2.

From the outer edges of these ribs run short grooves *i i*.

This dressing is made deep enough to admit all the grain between the ribs desired.

Both sides of the running ring D being cut in the same manner they are used at the same time.

Having thus fully described my invention, What I claim as new, and desire to secure by Letters Patent, is—

1. The running ring D cut alike on both sides, with ribs *g h* on a smooth surface, and the grooves *i i*, substantially as and for the purposes herein set forth.

2. The stationary ring H, (or H') cut, as described, with circular grooves *e e* and curved ribs *f f*, and used in combination with a running ring, substantially as and for the purposes set forth.

3. The head C, secured on the shaft B and provided with arms *a a*, in combination with the grinding-ring D, substantially as set forth.

4. The movable arbor E with head G and ring H, in combination with the movable hopper I and ring H', all constructed and arranged, as specified, to be operated by means of the lever K and arms J J', or other suitable means, substantially as and for the purposes herein set forth.

In testimony that I claim the foregoing I have hereunto set my hand this 14th day of November 1870

MYRON GORE.

Witnesses:

O. LEAVENS,
N. K. BROWN.