

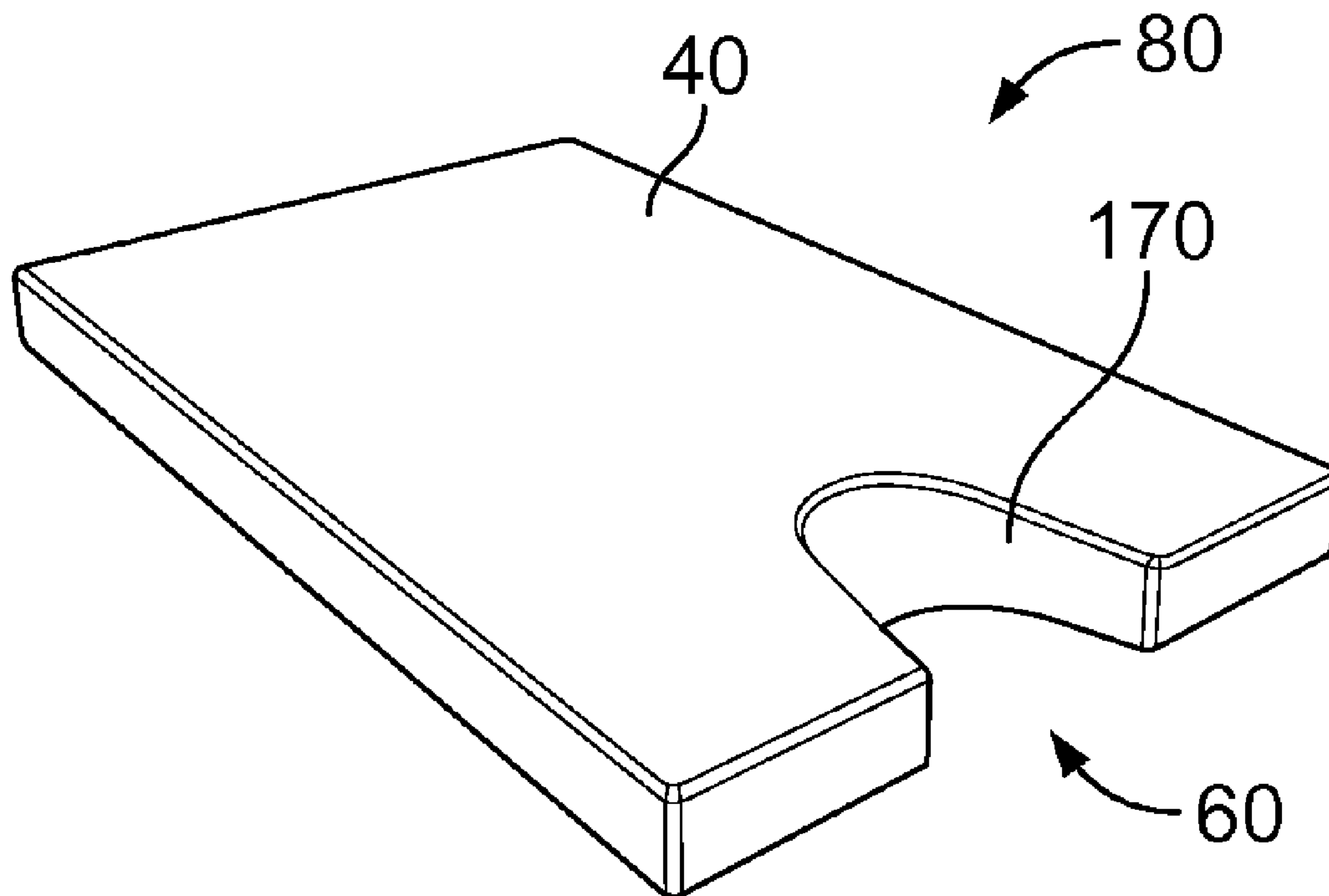

(86) **Date de dépôt PCT/PCT Filing Date:** 2013/02/07
(87) **Date publication PCT/PCT Publication Date:** 2013/08/15
(45) **Date de délivrance/Issue Date:** 2018/03/20
(85) **Entrée phase nationale/National Entry:** 2014/07/31
(86) **N° demande PCT/PCT Application No.:** US 2013/025195
(87) **N° publication PCT/PCT Publication No.:** 2013/119848
(30) **Priorités/Priorities:** 2012/02/07 (US61/633,288);
2013/02/06 (US13/760,974)

(51) **Cl.Int./Int.Cl. A63B 6/00** (2006.01)
(72) **Inventeur/Inventor:**
LONG, RAYMOND, US
(73) **Propriétaire/Owner:**
LONG, RAYMOND, US
(74) **Agent:** BORDEN LADNER GERVAIS LLP

(54) **Titre : TAPIS D'EXERCICE**
(54) **Title: EXERCISE MAT**



(57) **Abrégé/Abstract:**

An exercise mat for a person exercising on a floor surface comprises a pad having a top surface, a bottom surface, and a peripheral edge. A cutout is formed in a first portion of the peripheral edge and sized to accommodate the neck of the person. A high-friction non-slip texture or coating may be applied to either the top surface or the bottom surface of the pad, or both. The top surface may further includes a pair of raised shoulder stops. In use, with the bottom surface of the pad resting on the floor surface and with the person's shoulders supported on opposing sides of the cutout proximate the first portion of the peripheral edge, the person's neck may be positioned within the cutout to allow natural flexion curvature of the cervical spine when the person is performing a shoulder stand on the mat.

(12) INTERNATIONAL APPLICATION PUBLISHED UNDER THE PATENT COOPERATION TREATY (PCT)

(19) World Intellectual Property
Organization
International Bureau(43) International Publication Date
15 August 2013 (15.08.2013)(10) International Publication Number
WO 2013/119848 A1

(51) International Patent Classification:

A63B 6/00 (2006.01)

(21) International Application Number:

PCT/US2013/025195

(22) International Filing Date:

7 February 2013 (07.02.2013)

(25) Filing Language:

English

(26) Publication Language:

English

(30) Priority Data:

61/633,288 7 February 2012 (07.02.2012) US

13/760,974 6 February 2013 (06.02.2013) US

(72) Inventor; and

(71) Applicant : **LONG, Raymond** [US/US]; 777 North Ashley Unit 1103, Tampa, Florida 33602 (US).(74) Agent: **PRINCE, Kevin**; 2580 Anthem Village Dr., Henderson, Nevada 89052 (US).(81) Designated States (*unless otherwise indicated, for every kind of national protection available*): AE, AG, AL, AM, AO, AT, AU, AZ, BA, BB, BG, BH, BN, BR, BW, BY, BZ, CA, CH, CL, CN, CO, CR, CU, CZ, DE, DK, DM,

DO, DZ, EC, EE, EG, ES, FI, GB, GD, GE, GH, GM, GT, HN, HR, HU, ID, IL, IN, IS, JP, KE, KG, KM, KN, KP, KR, KZ, LA, LC, LK, LR, LS, LT, LU, LY, MA, MD, ME, MG, MK, MN, MW, MX, MY, MZ, NA, NG, NI, NO, NZ, OM, PA, PE, PG, PH, PL, PT, QA, RO, RS, RU, RW, SC, SD, SE, SG, SK, SL, SM, ST, SV, SY, TH, TJ, TM, TN, TR, TT, TZ, UA, UG, US, UZ, VC, VN, ZA, ZM, ZW.

(84) Designated States (*unless otherwise indicated, for every kind of regional protection available*): ARIPO (BW, GH, GM, KE, LR, LS, MW, MZ, NA, RW, SD, SL, SZ, TZ, UG, ZM, ZW), Eurasian (AM, AZ, BY, KG, KZ, RU, TJ, TM), European (AL, AT, BE, BG, CH, CY, CZ, DE, DK, EE, ES, FI, FR, GB, GR, HR, HU, IE, IS, IT, LT, LU, LV, MC, MK, MT, NL, NO, PL, PT, RO, RS, SE, SI, SK, SM, TR), OAPI (BF, BJ, CF, CG, CI, CM, GA, GN, GQ, GW, ML, MR, NE, SN, TD, TG).**Published:**

- with international search report (Art. 21(3))
- before the expiration of the time limit for amending the claims and to be republished in the event of receipt of amendments (Rule 48.2(h))

(54) Title: EXERCISE MAT

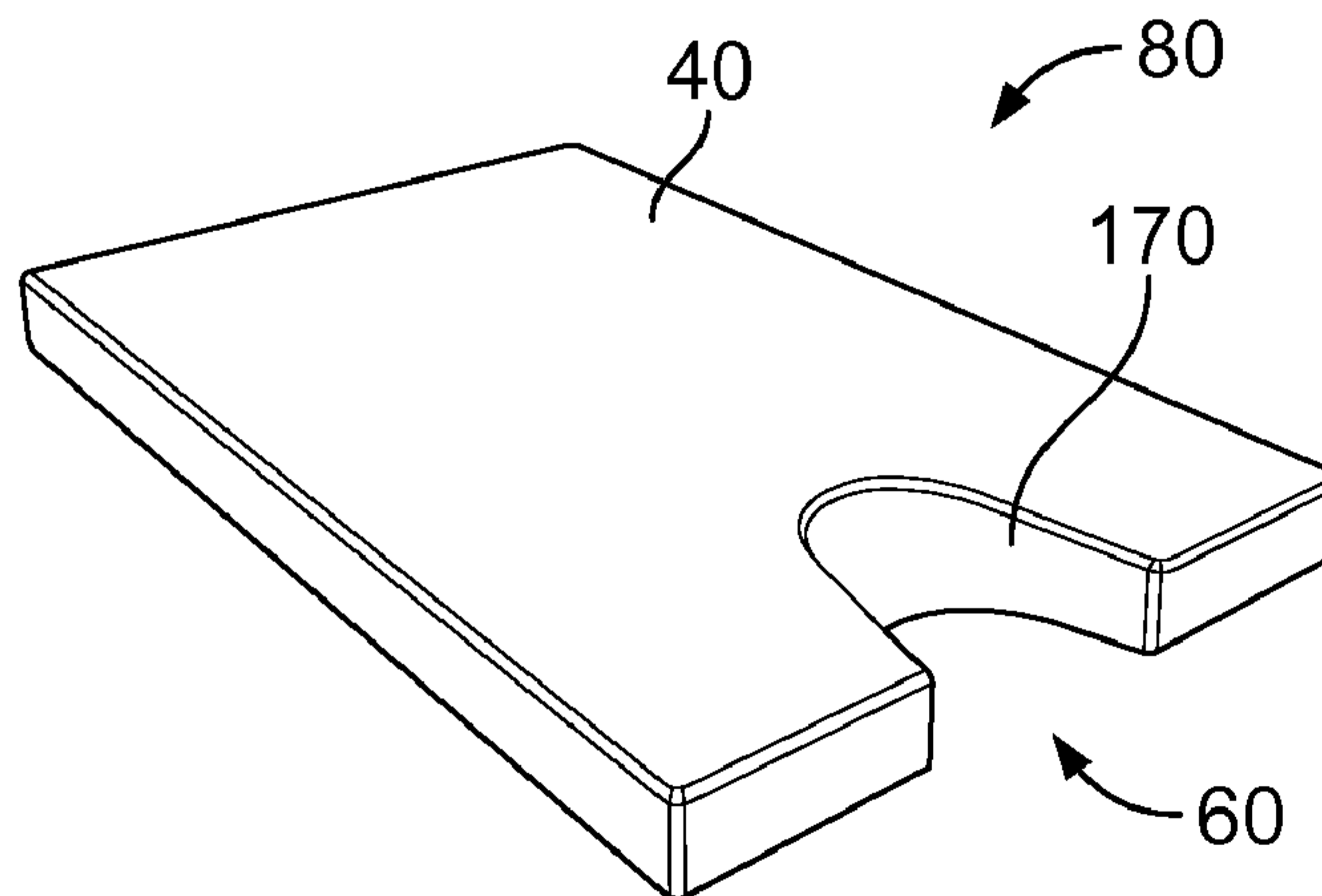

(57) **Abstract:** An exercise mat for a person exercising on a floor surface comprises a pad having a top surface, a bottom surface, and a peripheral edge. A cutout is formed in a first portion of the peripheral edge and sized to accommodate the neck of the person. A high-friction non-slip texture or coating may be applied to either the top surface or the bottom surface of the pad, or both. The top surface may further includes a pair of raised shoulder stops. In use, with the bottom surface of the pad resting on the floor surface and with the person's shoulders supported on opposing sides of the cutout proximate the first portion of the peripheral edge, the person's neck may be positioned within the cutout to allow natural flexion curvature of the cervical spine when the person is performing a shoulder stand on the mat.



WO 2013/119848 A1

TITLE: EXERCISE MAT

INVENTOR: RAYMOND LONG

FIELD OF THE INVENTION

This invention relates to exercise and stretching devices, and more particularly to an ergonomic yoga mat.

1 **DISCUSSION OF RELATED ART**

2

3 Shoulder Stand or, in Sanskrit, "Sarvangasana" and its variations are common poses
4 used in the practice of yoga and also Pilates. There are recently published cautions
5 relating to this pose that encourage placing a firm support underneath the lower part
6 of the neck, shoulders, upper arms and elbows, with the objective of preventing hyper
7 flexion of the cervical spine.

8

9 The rationale for this is that raising the shoulders above the floor on several blankets
10 or a foam plank allows the neck to extend somewhat, thereby theoretically removing
11 stress on the interspinous ligaments of the neck. The instruction usually given is to
12 fold several firm blankets and perform the pose with the shoulders and arms
13 supported on the blankets while the head hangs over the edge.

14

15 This approach has a number of shortcomings that actually expose the practitioner to
16 other hazards. First, the lower three cervical vertebrae (C5-C7) are at the level of the
17 shoulders in this pose. Thus, performing the pose with a stack of blankets or plank
18 under the shoulders necessarily also places the weight of the body on these lower
19 cervical vertebrae. In this manner, rather than distributing the flexion curvature over
20 the entire cervical spine, performing the pose while elevated on blankets or plank
21 actually concentrates the body weight on the lower cervical vertebrae. At the same
22 time, an unnatural curvature is produced in the upper levels of the cervical spine from
23 the head hanging over the edge of the blankets so that the cervical spine is subjected
24 to an "S" or sigmoidal type curvature with both flexion and extension taking place.
25 Additionally, in order to hang the head over the edge of the blankets it is necessary to

1 have the shoulders precipitously close to the edge of the blankets or plank. As a result,
2 many practitioners accidentally slide off the blankets or plank resulting in a sudden,
3 unexpected flexion moment on the cervical spine. This is especially true as the
4 practitioner transitions from Shoulder Stand to Plow Pose (with the legs and feet
5 lowered to the floor). The remedy for this is to place the shoulders and neck further
6 onto the blankets or plank and away from the edge and allow only the very top
7 cervical vertebrae and head to hang over the edge—or be completely on the blanket or
8 plank. This defeats the purpose of raising the shoulders in the first place and can result
9 in an even more abnormal curvature in the upper cervical spine.

10

11 Thus, the goal of performing a shoulder stand and its variations on a stack of blankets
12 or plank—with the supposed benefit of removing some of the flexion from the
13 cervical spine—is not accomplished by this commonly practiced technique. In fact,
14 risk to the cervical spine is enhanced by the possibility of sliding off the blankets,
15 concentrating curvature onto the lower cervical vertebrae, and producing an unnatural
16 curve in the cervical spine.

17

18 Ergonomic pillows might conceivably be employed to provide clearance for the neck
19 of a person while performing a shoulder stand, yet still support the person's shoulders
20 above the floor surface. For example, US 2,835,905 to Tomasson on June 8, 1954
21 teaches a pillow with a cutout cut into one side. Likewise, US Patent 3,009,172 to
22 Eidam on July 27, 1959 teaches a head supporting pillow with a cutout. However, the
23 top surfaces of both of these prior art pillows are slanted in such a way as to make
24 them unsuitable for stably supporting the shoulders of a person in a shoulder stand
25 pose. Further, such prior art pillows are not long enough to support the person's torso

1 when beginning or ending such a pose, and in fact would be so short as to provide a
2 risk of flipping dangerously on their front ends if used for such a purpose.

3
4 US Patent 5,457,832 on Oct. 17, 1995 to Tatum teaches a cervical pillow with
5 variable thickness head and neck portions, and is designed for supporting a person's
6 head and neck while sleeping in a reclined position. Such a device suffers from the
7 same drawbacks as the previously-mentioned ergonomic pillows in that a person's
8 shoulders would be dangerously unstable if used for aiding in a shoulder stand pose.

9
10 US Patent 7,707,668 to Kloes et al. on May 4, 2010 teaches an head supporting pillow
11 with a neck cutout, but like the previously-mentioned patents such a device is not long
12 enough to support the person's torso when beginning or ending such a pose, and the
13 neck cutout is not shaped in such a way as to accommodate a person's neck
14 comfortably while supported thereon and performing a shoulder stand pose.

15
16 US Design Patent D444,980 to Mowat et al. on July 17, 2001 teaches an ergonomic
17 pillow having a recessed portion in a front edge that could conceivably be used for
18 supporting a person conducting a shoulder stand. However, such a device is shaped
19 that it could dangerously flip up on its front edge during such use, and is also not long
20 enough to support the person's torso when beginning or ending such a pose.

21
22 Therefore, there is a need for an exercise support pad that provides a suitably-shaped
23 cutout in a front edge thereof for accommodating a person's neck while performing a
24 shoulder stand pose. Such a needed device would be long enough to support the
25 person's torso when beginning or ending such a pose, and provide means for

1 inhibiting the person's shoulders from dangerously slipping off the front edge of the
2 mat. Such a needed invention would be stable and designed not to flip over during
3 use. The present invention accomplishes these objectives.

4

5

6 SUMMARY OF THE INVENTION

7

8 The present device is an exercise mat for a person exercising on a floor surface. The
9 mat comprises a pad having a top surface, a bottom surface, and a peripheral edge.

10 The shape of the pad may be rectangular, oval, square, or other shape as suited for the
11 proper use of the mat. The pad is preferably made from a soft foam material.

12

13 A cutout is formed in a first portion of the peripheral edge and sized to accommodate
14 the neck of the person. In one embodiment, the cutout is formed equally through the
15 top and bottom surfaces of the pad. Alternately, the cutout is formed in the top
16 surface of the pad to a depth greater than a depth formed in the bottom surface of the
17 pad. As such, the peripheral edge of the pad at the cutout services to create a gentle
18 curve in the cervical spine of the person appropriate for the shoulder stand pose.

19

20 In one embodiment, the cutout is formed in the top surface and the first portion of the
21 peripheral edge of the pad but not through the bottom surface of the pad. The cutout
22 may be defined, in one embodiment, by a pair of shoulder supporting projections
23 projecting away from the first portion of the peripheral edge of the pad. The shape of
24 the cutout may be a half-circle, a rectangle, a triangle, a half-oval, or other shapes

1 provided the shoulders may be well supported on either side thereof without the neck
2 of the person being bent as with the prior art devices.

3
4 In one embodiment a high-friction non-slip texture or coating is applied to either the
5 top surface or the bottom surface of the pad, or both. In one embodiment, the top
6 surface further includes a pair of raised shoulder stops proximate the first portion of
7 the peripheral edge of the pad, which aids the prevention of the person's shoulders
8 slipping off of the pad during the shoulder stand pose, which can result in neck and
9 back injury. Additionally, shoulder troughs may be included proximate the first
10 portion of the peripheral edge of the pad to aid in the prevention of the person's
11 shoulders slipping off of the pad during the shoulder stand pose.

12
13 In use, with the bottom surface of the pad resting on the floor surface and with the
14 person's shoulders supported on opposing sides of the cutout proximate the first
15 portion of the peripheral edge, the person's neck may be positioned within the cutout
16 to allow natural flexion curvature of the cervical spine when the person is performing
17 a shoulder stand on the mat. This contrasts with the sharp, unnatural and dangerous
18 bend in the cervical spine when using an exercise mat of the prior art. A pair of
19 shoulder guides may be applied to the top surface of the pad to assist the person with
20 proper alignment of his shoulders on the pad.

21
22 The present invention is an exercise support pad that provides a suitably-shaped
23 cutout in a front edge thereof for accommodating a person's neck while performing a
24 shoulder stand pose. The present invention is long enough to support the person's
25 torso when beginning or ending such a pose, and provides means for inhibiting the

1 person's shoulders from dangerously slipping off the front edge of the mat. The
2 present invention is stable and designed not to flip over during use. Other features
3 and advantages of the present invention will become apparent from the following
4 more detailed description, taken in conjunction with the accompanying drawings,
5 which illustrate, by way of example, the principles of the invention.

6

7

8 **DESCRIPTION OF THE DRAWINGS**

9

10 FIG. 1 is a perspective diagram illustrating the prior art and the effect thereof on spine

11 curvature for a person, represented by a skeleton, doing a shoulder stand;

12 FIG. 2 is a perspective diagram illustrating the improved gradual curvature of the

13 spine for those using the instant invention;

14 FIG. 3 is a perspective view of one embodiment of the invention;

15 FIG. 4 is a front elevational view of FIG. 3;

16 FIG. 5 is a side elevational view of FIG. 3;

17 FIG. 6 is a top plan view of an alternate embodiment of the invention;

18 FIG. 7 is a perspective view of another alternate embodiment of the invention,

19 illustrating a pair of shoulder stops thereof;

20 FIG. 8 is an embodiment having an oval-shaped pad;

21 FIG. 9 is an embodiment having a triangular-shaped cutout;

22 FIG. 10 is an embodiment having a pair of shoulder supporting projections;

23 FIG. 11 is a top plan view of a set of alternate embodiments employing different

24 shaped cutouts;

25 FIG. 12 is a perspective view of an embodiment having a conically-shaped cutout;

1 FIG. 13 is a perspective view of a pad having rounded edges;
2 FIG. 14 is a left-side elevational view of an embodiment having shoulder troughs;
3 FIG. 15 is a left-side elevational diagram of a pad with an insufficient length to
4 support the lumbar spine of the person; and
5 FIG. 16 is a left-side elevational diagram of a pad having a sufficient length to support
6 the lumbar spine of the person.

7

8

9 **DETAILED DESCRIPTION OF THE PREFERRED EMBODIMENT**

10

11 Illustrative embodiments of the invention are described below. The following
12 explanation provides specific details for a thorough understanding of and enabling
13 description for these embodiments. One skilled in the art will understand that the
14 invention may be practiced without such details. In other instances, well-known
15 structures and functions have not been shown or described in detail to avoid
16 unnecessarily obscuring the description of the embodiments.

17

18 Unless the context clearly requires otherwise, throughout the description and the
19 claims, the words "comprise," "comprising," and the like are to be construed in an
20 inclusive sense as opposed to an exclusive or exhaustive sense; that is to say, in the
21 sense of "including, but not limited to." Words using the singular or plural number
22 also include the plural or singular number respectively. Additionally, the words
23 "herein," "above," "below" and words of similar import, when used in this
24 application, shall refer to this application as a whole and not to any particular portions
25 of this application. When the claims use the word "or" in reference to a list of two or

1 more items, that word covers all of the following interpretations of the word: any of
2 the items in the list, all of the items in the list and any combination of the items in the
3 list. When the word “each” is used to refer to an element that was previously
4 introduced as being at least one in number, the word “each” does not necessarily
5 imply a plurality of the elements, but can also mean a singular element.

6
7 FIGS. 2-5 illustrate an exercise mat 10 for a person 20 exercising on a floor surface
8 30. The mat 10 comprises a pad 40 having a top surface 48, a bottom surface 42, and
9 a peripheral edge 45. The pad 40 has an average height H and at least a first portion
10 50 of the peripheral edge 45 referred to generally in the illustrates as the front edge of
11 the pad 40.

12
13 The shape of the pad 40 is somewhat flexible in that the pad 40 may be a rectangular
14 pad 80 (FIG. 3), an oval pad 90 (FIG. 8), a square pad 100 (FIG. 9), or other shapes as
15 suited for the proper use of the mat 10. Certain dimensions of the pad 40 are
16 preferred, such as the general height H (FIG. 5) of the pad 40 being between one and
17 five inches, the width W_1 (FIG. 4) of the pad 40 being between 12 and 40 inches, and
18 the length L of the pad 40 being between 15 and 50 inches, but preferably longer than
19 36 inches to reduce the risk of hyperextending the lumbar spine 22 when the person
20 comes out of the shoulder stand position (FIGS. 15 and 16), and to accommodate the
21 entire torso of the person 20 so that the sacrum is lowered onto the mat 10, rather than
22 hyper extending the lumbar spine 22 while lowering out of the shoulder stand pose
23 onto the floor 30.

24

1 The pad 40 is preferably made from a soft foam material, such as an EVA foam
2 material having a hardness of between 20 and 40 shore. The pad 40 is preferably not
3 so soft that the weight of the person 20 compresses the pad 40 to a height of less than
4 one or two inches, but preferably closer to three inches. The pad 40 may include a
5 cover (not shown) made of a flexible fabric or other flexible material that is preferably
6 machine washable, durable and comfortable to the touch, such as cotton.

7
8 A cutout 60 is formed in the first portion 50 of the peripheral edge 45 and sized to
9 accommodate the neck 25 of the person 20, preferably to a depth D of at least 6 inches
10 (FIG. 13) and a width W_2 (FIG. 4) of between 6 and 10 inches. W_2 is necessarily not
11 much wider, at a maximum, than the width of the person's head so as to ensure proper
12 shoulder support of the person 20. In one embodiment, the cutout 60 is formed
13 equally through the top and bottom surfaces 48,42 of the pad 40 (FIGS. 9-11 and 13).
14 Alternately, the cutout 60 is formed in the top surface 48 of the pad 40 to a depth D_2
15 greater than a depth D_1 formed in the bottom surface 42 of the pad 40 (FIGS. 6, 8 and
16 12), where preferably D_1 is between 5 and 7 inches and D_2 is between 8 and 10
17 inches. As such, the peripheral edge 45 of the pad 40 at the cutout 60 services to
18 create a gentle curve in the cervical spine 23 of the person 20 appropriate for the
19 shoulder stand pose.

20
21 In one embodiment, the cutout 60 is formed in the top surface 48 and the first portion
22 50 of the peripheral edge 45 of the pad 40 but not through the bottom surface 42 of
23 the pad 40 (FIG. 12). The cutout 60 may be defined, in one embodiment, by a pair of
24 shoulder supporting projections 130 projecting away from the first portion 50 of the
25 peripheral edge 45 of the pad 40 (FIG. 10). The shape of the cutout 60 may be a half-

1 circle 140 (FIG. 8), a rectangle 150 (FIG. 10), a triangle 160 (FIG. 9), or a half-oval
2 (FIG. 13). Other shapes as shown in FIG. 11, including cutouts 60 that are apertures
3 170 or recesses 180, may also be used, provided the shoulders 24 may be well
4 supported on either side thereof without the neck 25 of the person 20 being bent as
5 with the prior art devices.

6
7 In one embodiment a high-friction non-slip texture 110 or coating is applied to either
8 the top surface 48 or the bottom surface 42 of the pad 40, or both (FIG. 8). In one
9 embodiment, the top surface 48 further includes a pair of raised shoulder stops 120
10 (FIG. 7) proximate the first portion 50 of the peripheral edge 45 of the pad 40, which
11 aids the prevention of the person's shoulders 24 slipping off of the pad 40 during the
12 shoulder stand pose, which can result in neck and back injury. Additionally, shoulder
13 troughs 125 may be included proximate the first portion 50 of the peripheral edge 45
14 of the pad 40 to aid in the prevention of the person's shoulders 24 slipping off of the
15 pad 40 during the shoulder stand pose.

16
17 In use, with the bottom surface 42 of the pad 40 resting on the floor surface 30 and
18 with the person's shoulders 24 supported on opposing sides 70 of the cutout 60
19 proximate the first portion 50 of the peripheral edge 40, the person's neck 25 may be
20 positioned within the cutout 60 to allow natural flexion curvature of the cervical spine
21 23 when the person 20 is performing a shoulder stand on the mat 10 (FIG. 2). This
22 contrasts with the sharp, unnatural and dangerous bend in the cervical spine 23 when
23 using an exercise mat of the prior art (FIG. 1). A pair of shoulder guides 126 (FIG. 6)
24 may be applied to the top surface 48 of the pad 40 to assist the person 20 with proper
25 alignment of his shoulders 24 on the pad 40. A separate foot plank or pad (not

1 shown) may be further included to aid in dismounting from the shoulder stand pose to
2 the so-called plow pose.

3
4 While a particular form of the invention has been illustrated and described, it will be
5 apparent that various modifications can be made without departing from the spirit and
6 scope of the invention. Accordingly, it is not intended that the invention be limited,
7 except as by the appended claims.

8
9 Particular terminology used when describing certain features or aspects of the
10 invention should not be taken to imply that the terminology is being redefined herein
11 to be restricted to any specific characteristics, features, or aspects of the invention
12 with which that terminology is associated. In general, the terms used in the following
13 claims should not be construed to limit the invention to the specific embodiments
14 disclosed in the specification, unless the above Detailed Description section explicitly
15 defines such terms. Accordingly, the actual scope of the invention encompasses not
16 only the disclosed embodiments, but also all equivalent ways of practicing or
17 implementing the invention.

18
19 The above detailed description of the embodiments of the invention is not intended to
20 be exhaustive or to limit the invention to the precise form disclosed above or to the
21 particular field of usage mentioned in this disclosure. While specific embodiments of,
22 and examples for, the invention are described above for illustrative purposes, various
23 equivalent modifications are possible within the scope of the invention, as those
24 skilled in the relevant art will recognize. Also, the teachings of the invention
25 provided herein can be applied to other systems, not necessarily the system described

above. The elements and acts of the various embodiments described above can be combined to provide further embodiments.

Aspects of the invention can be modified, if necessary, to employ the systems, functions, and concepts of the various references described herein above to provide yet further embodiments of the invention.

Changes can be made to the invention in light of the above “Detailed Description”.

While the above description details certain embodiments of the invention and describes the best mode contemplated, no matter how detailed the above appears in text, the invention can be practiced in many ways. Therefore, implementation details may vary considerably while still being encompassed by the invention disclosed herein. As noted above, particular terminology used when describing certain features or aspects of the invention should not be taken to imply that the terminology is being redefined herein to be restricted to any specific characteristics, features, or aspects of the invention with which that terminology is associated.

While certain aspects of the invention are presented below in certain claim forms, the inventor contemplates the various aspects of the invention in any number of claim forms. Accordingly, the inventor reserves the right to add additional claims after filing the application to pursue such additional claim forms for other aspects of the invention.

CLAIMS:

1. An exercise mat for a person exercising on a floor surface, comprising:
a pad made from a foam material having a hardness of between 20 and 40 shore C for supporting the person while the person is performing a shoulder stand pose, the pad having a top surface, a bottom surface that is parallel to the top surface, and a peripheral edge, the pad having a height and at least a first portion of the peripheral edge; and
a cutout formed in the first portion of the peripheral edge, wherein the cutout is sized to accommodate the neck of the person and has a width between 6 and 10 inches;
wherein with the bottom surface of the pad resting on the floor surface and with the person's shoulders supported on opposing sides of the cutout proximate the first portion of the peripheral edge, the person's neck may be positioned within the cutout to allow natural flexion curvature of the cervical spine when the person is performing a shoulder stand on the mat, and wherein the pad has a length of between 36 and 50 inches.
2. The exercise mat of claim 1 wherein the first portion of the peripheral edge is a first side of a rectangular pad.
3. The exercise mat of claim 2 wherein the first portion of the peripheral edge is a first side of a generally square pad.

4. The exercise mat of claim 1 wherein the cutout is formed equally through the top and bottom surfaces of the pad.
5. The exercise mat of claim 1 wherein the cutout formed in the top surface of the pad is larger than the cutout formed in the bottom surface of the pad.
6. The exercise mat of claim 5 wherein the cutout is formed in the top surface of the pad but not in the bottom surface of the pad.
7. The exercise mat of claim 5 wherein a depth of the cutout formed in the bottom surface is between 5 and 9 inches, and the depth of the cutout formed in the top surface is between 8 and 12 inches.
8. The exercise mat of claim 1 wherein the bottom surface includes a high-friction nonslip texture.
9. The exercise mat of claim 1 wherein the top surface includes a high-friction non-slip texture.
10. The exercise mat of claim 1 wherein the first portion of the peripheral edge is a first side of a generally oval pad.

11. The exercise mat of claim 1 wherein the top surface further includes a pair of raised shoulder stops proximate the first portion of the peripheral edge.
12. The exercise mat of claim 1 wherein the first portion of the peripheral edge includes a pair of shoulder supporting projections, the cutout being defined therebetween.
13. The exercise mat of claim 1 wherein the height of the pad is between one and five inches.
14. The exercise mat of claim 1 wherein the width of the first part of the peripheral edge is between 12 and 40 inches.
15. The exercise mat of claim 1 wherein the cutout is generally in the shape of a half circle.
16. The exercise mat of claim 1 wherein the cutout is generally in the shape of a rectangle.
17. The exercise mat of claim 1 wherein the cutout is generally in the shape of a triangle.

18. The exercise mat of claim 1 wherein the cutout is generally in the shape of a half oval.
19. The exercise mat of claim 1 wherein the cutout is formed into the pad at least to a depth of six inches.
20. The exercise mat of claim 1 wherein the top surface further includes a pair of recessed shoulder troughs proximate the first portion of the peripheral edge.
21. The exercise mat of claim 1 wherein the foam material comprises EVA foam.
22. The exercise mat of claim 21 wherein the pad has a hardness such that the weight of the person compresses the pad from a height that is greater than about three inches to a height of about three inches.
23. The exercise mat of claim 1 wherein the pad has a hardness such that the weight of the person compresses the pad from a height that is greater than about three inches to a height of about three inches.
24. An exercise mat for a person exercising on a floor surface, comprising:
a pad made from a foam material having a hardness of between 20 and 40 shore C for supporting the person while the person is performing a shoulder stand pose, the pad having a top surface, a bottom surface that is parallel to the top surface, and a

peripheral edge, the pad having a height and at least a first portion of the peripheral edge; and

a cutout formed in the first portion of the peripheral edge, wherein the cutout is sized to accommodate the neck of the person and has a width between 6 and 10 inches;

wherein with the bottom surface of the pad resting on the floor surface and with the person's shoulders supported on opposing sides of the cutout proximate the first portion of the peripheral edge, the person's neck may be positioned within the cutout to allow natural flexion curvature of the cervical spine when the person is performing a shoulder stand on the mat, and wherein the pad is sized to accommodate the entire torso of the person.

25. An exercise mat for a person exercising on a floor surface, comprising:

a pad made from a foam material having a hardness of between 20 and 40 shore C for supporting the person while the person is performing a shoulder stand pose, the pad having a top surface, a bottom surface that is parallel to the top surface, and a peripheral edge, the pad having a height and at least a first portion of the peripheral edge; and

a cutout formed in the first portion of the peripheral edge, wherein the cutout is sized to accommodate the neck of the person and has a width between 6 and 10 inches;

wherein with the bottom surface of the pad resting on the floor surface and with the person's shoulders supported on opposing sides of the cutout proximate the first portion of the peripheral edge, the person's neck may be positioned within the cutout to allow natural flexion curvature of the cervical spine when the person is performing a

shoulder stand on the mat, and wherein the pad is long enough to support the elbows of the person when the person is performing a shoulder stand on the mat with the person's neck positioned within the cutout.

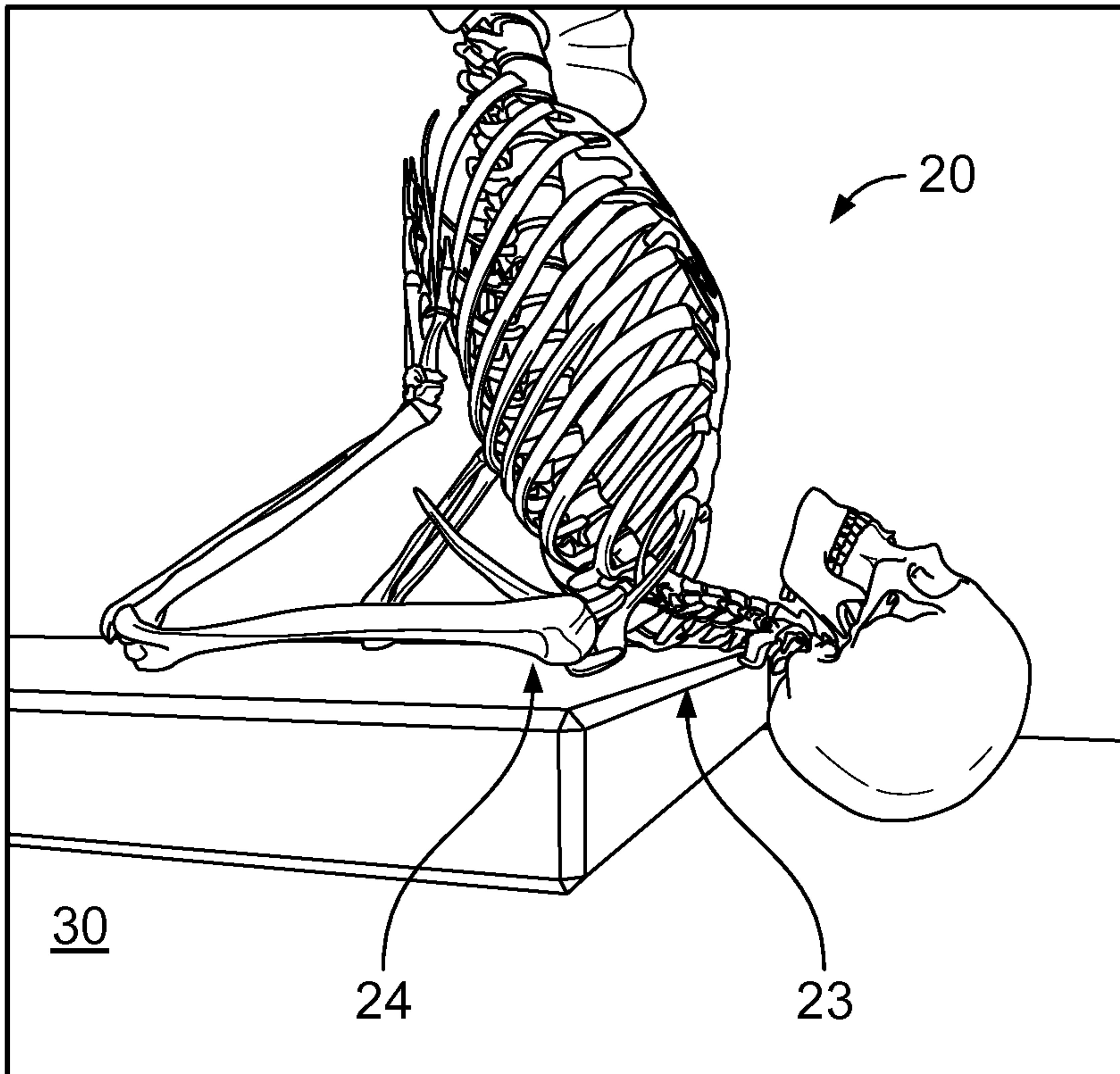

FIG. 1
(Prior Art)

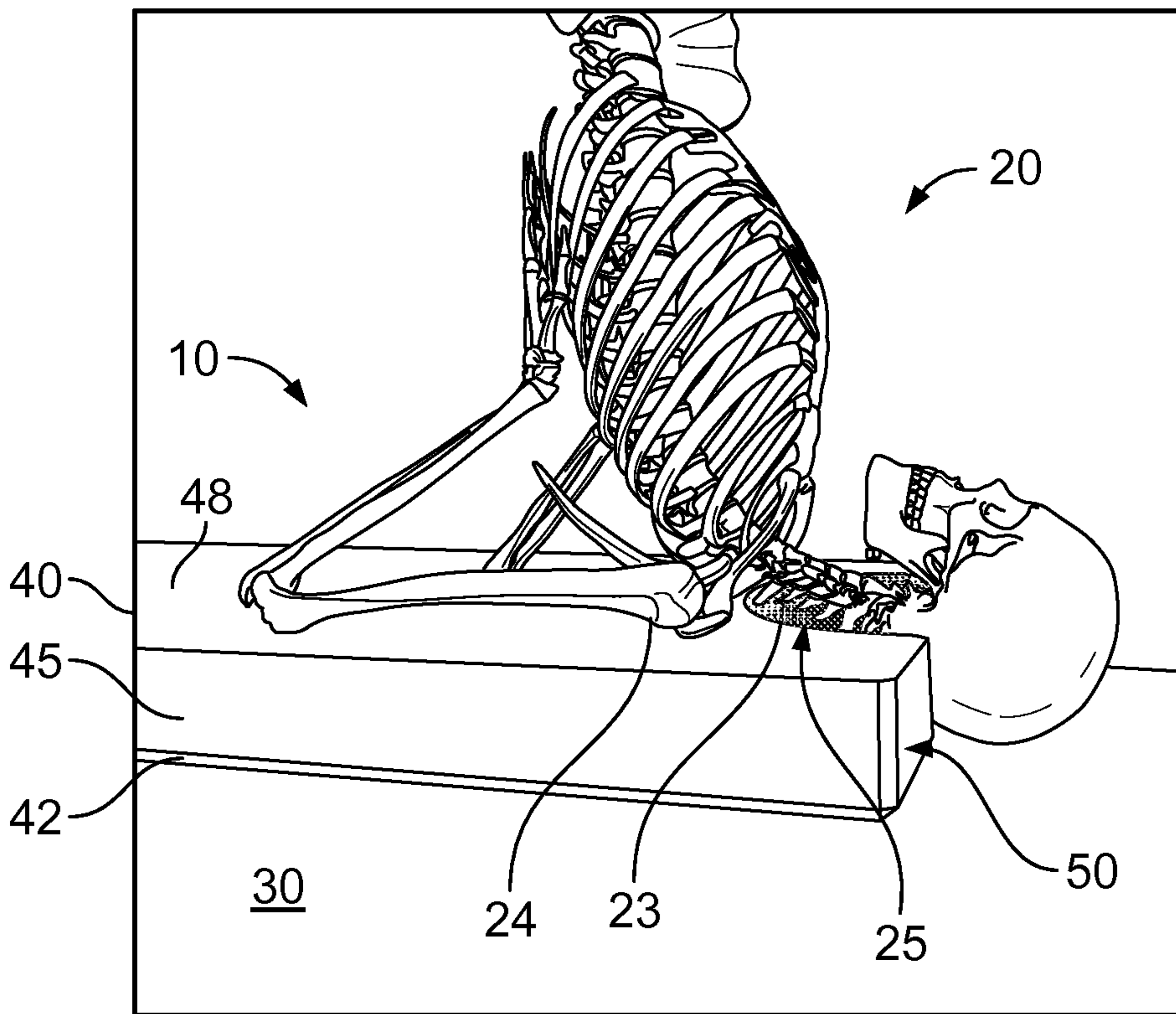

FIG. 2

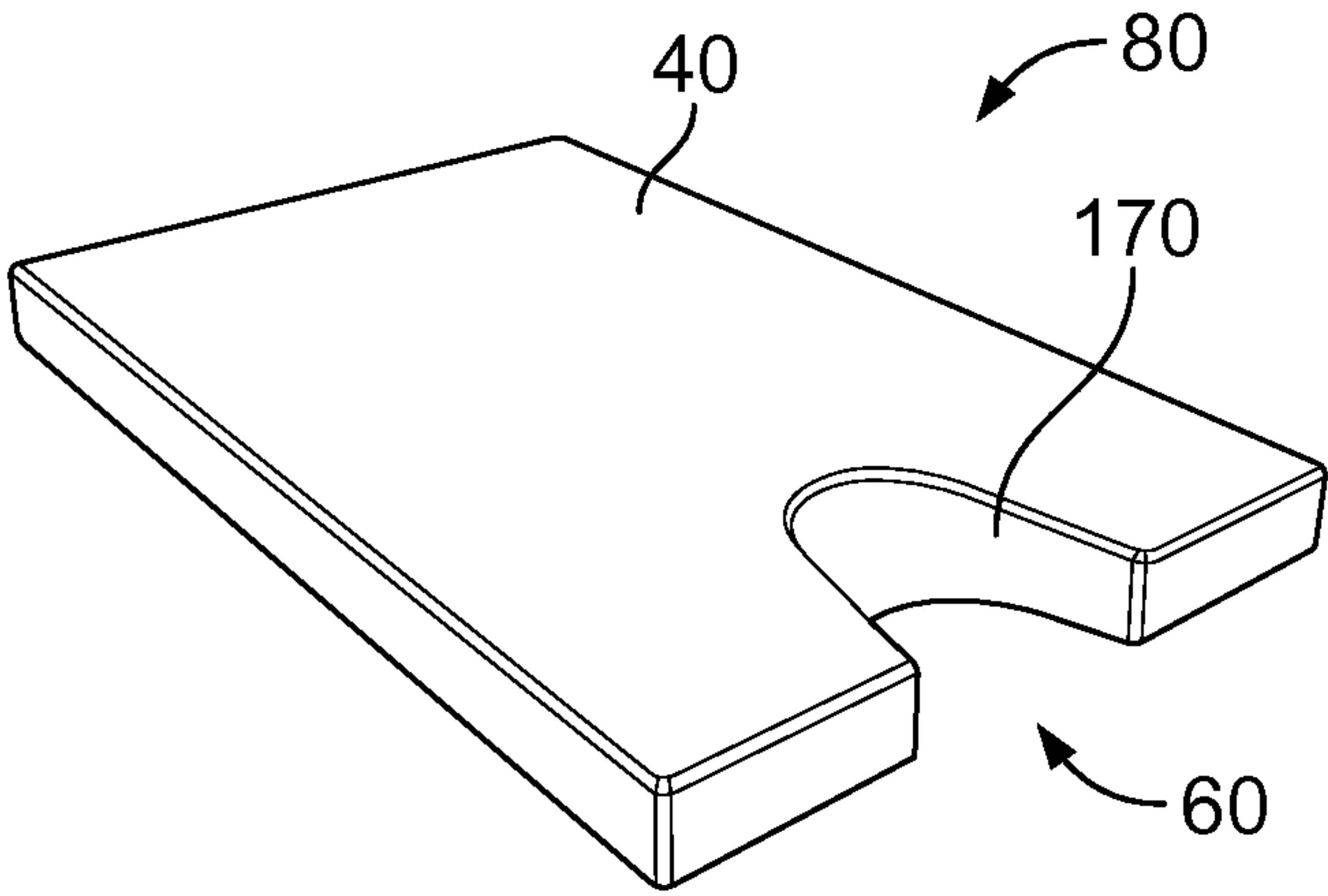

FIG. 3

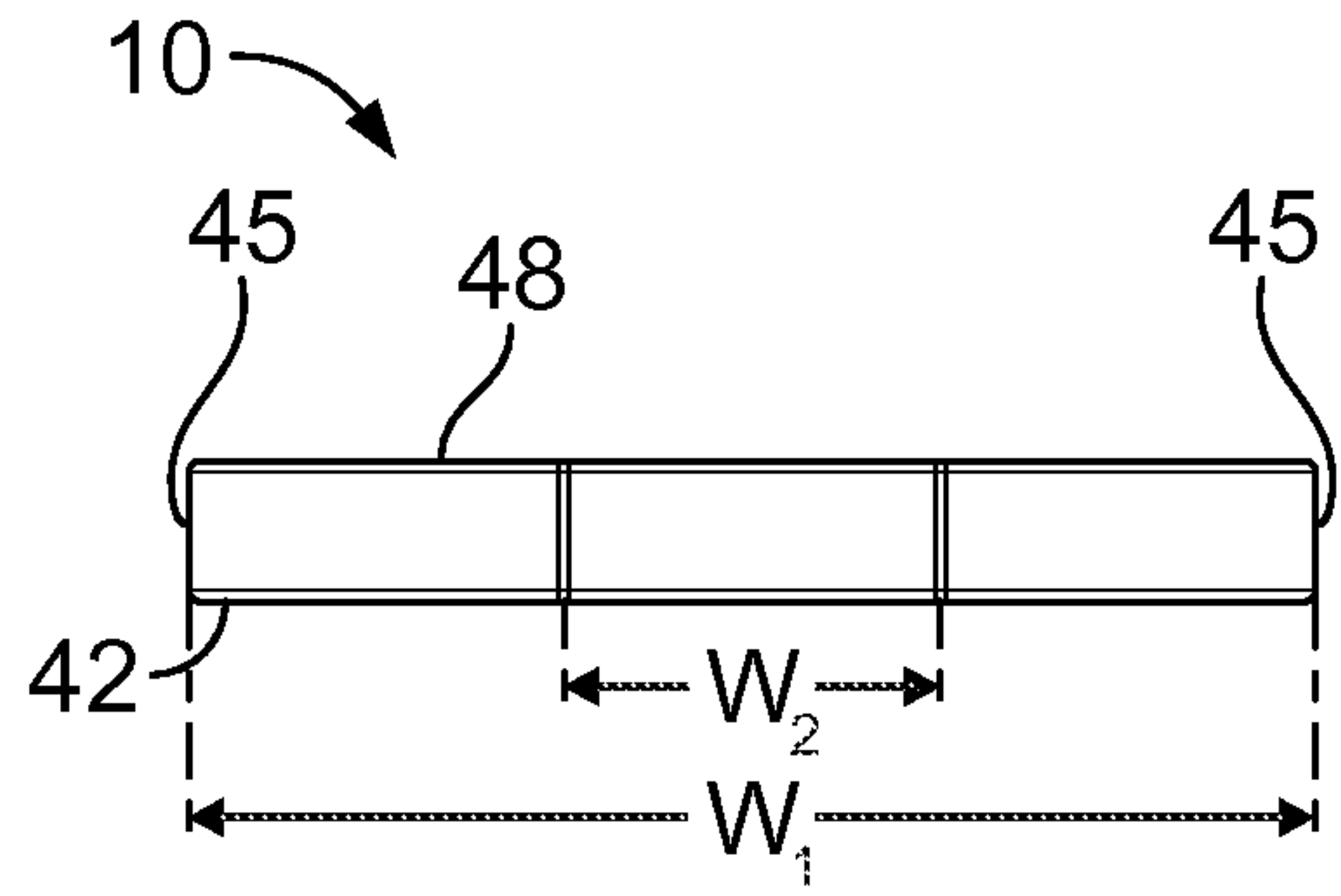

FIG. 4

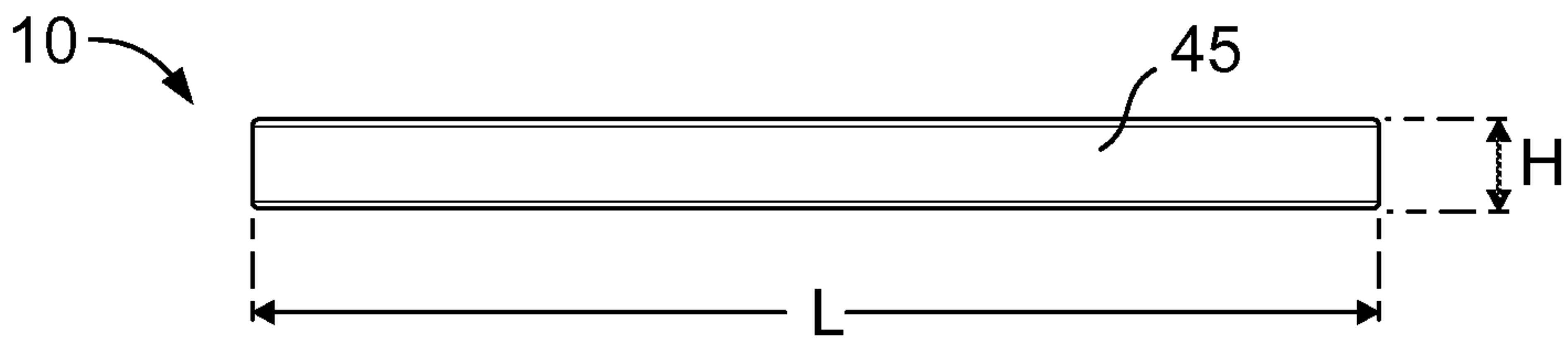

FIG. 5

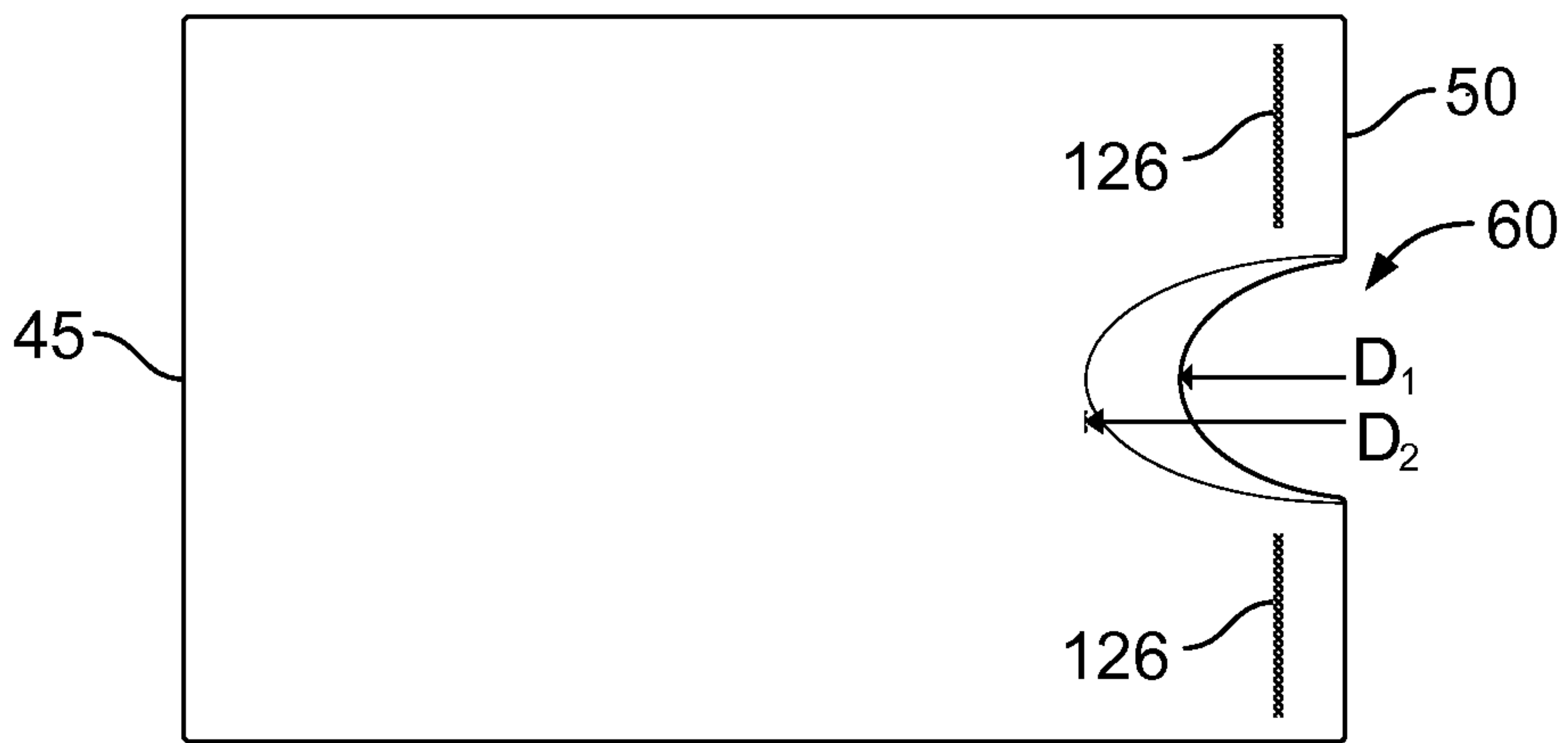

FIG. 6

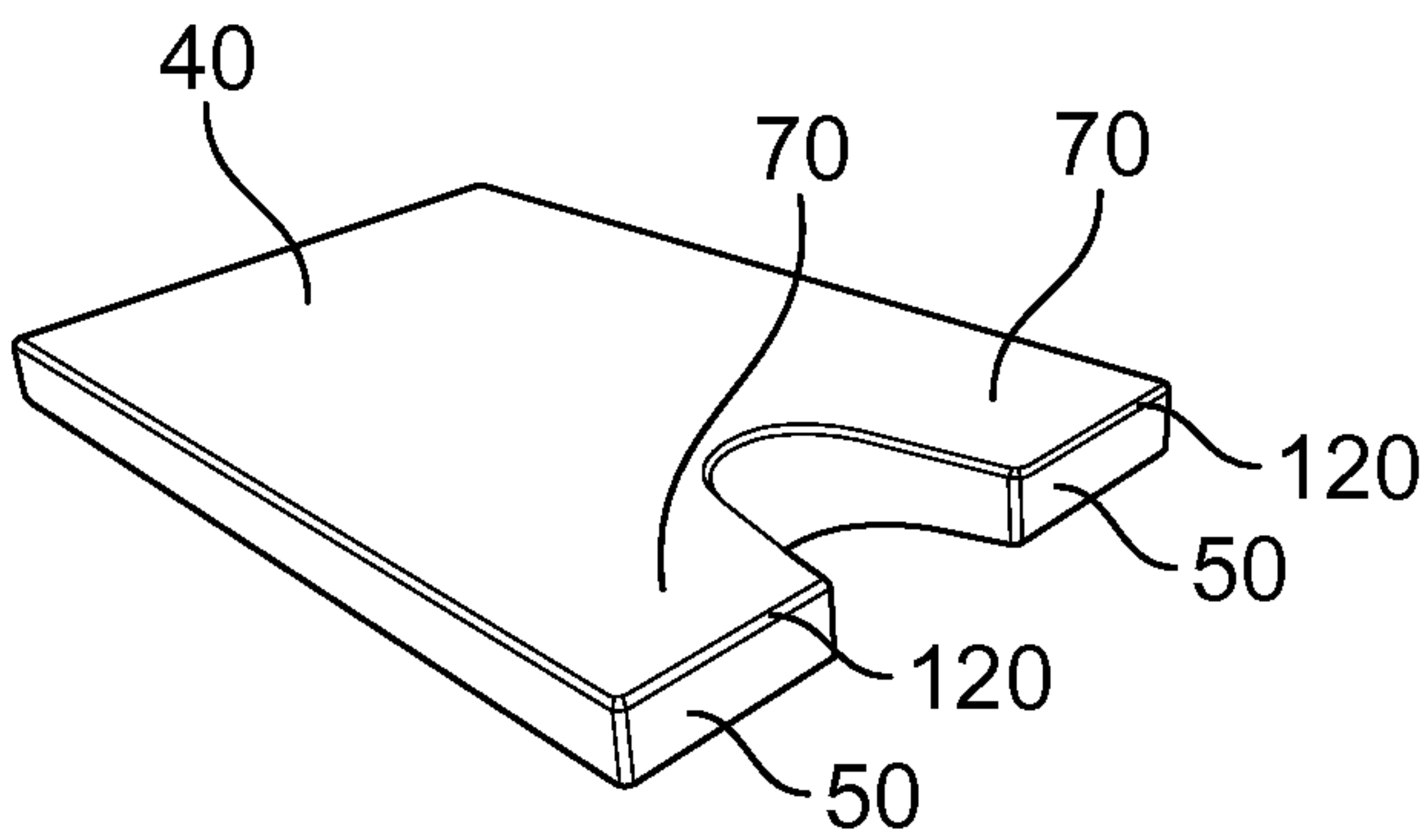

FIG. 7

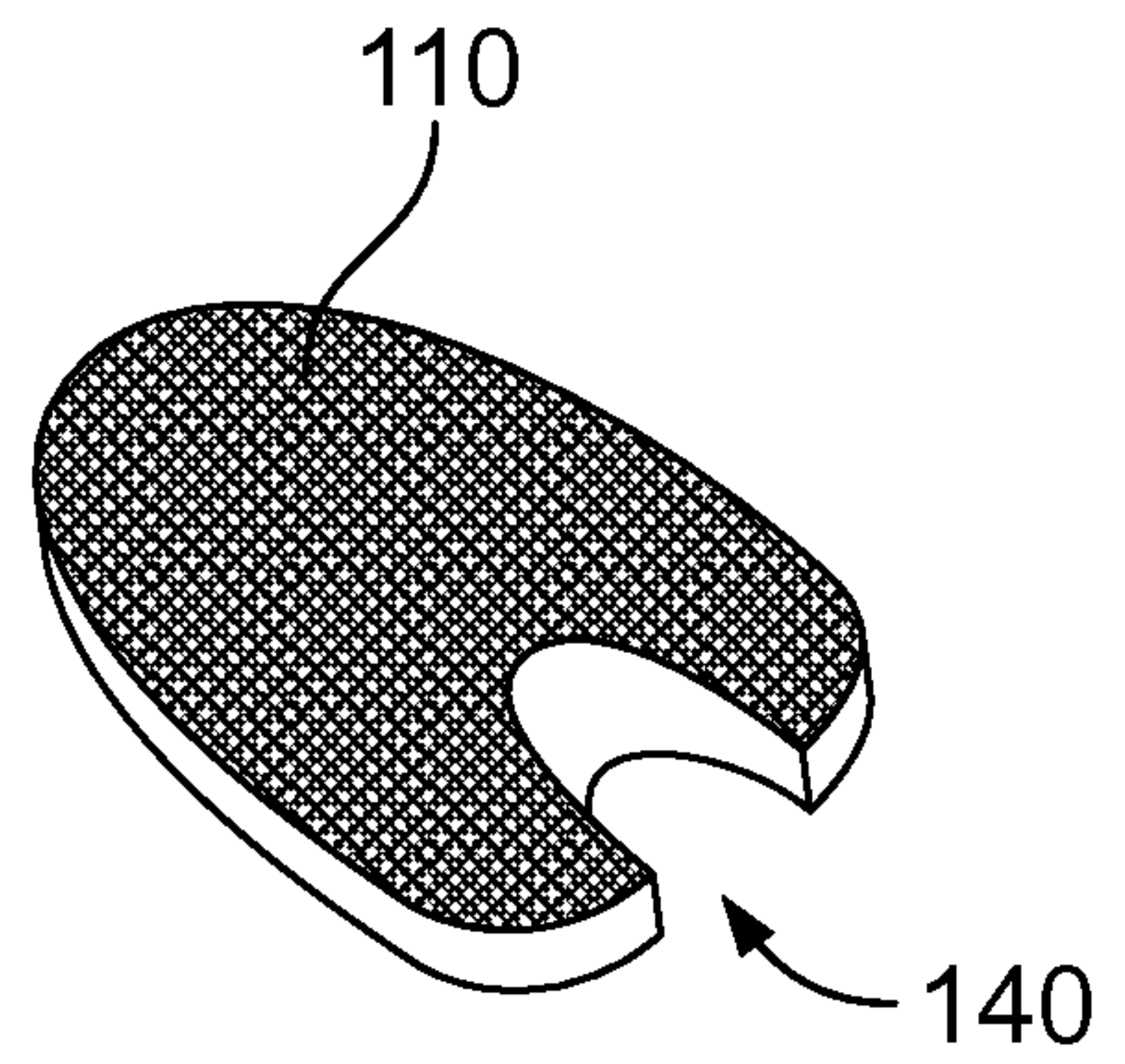

FIG. 8

10

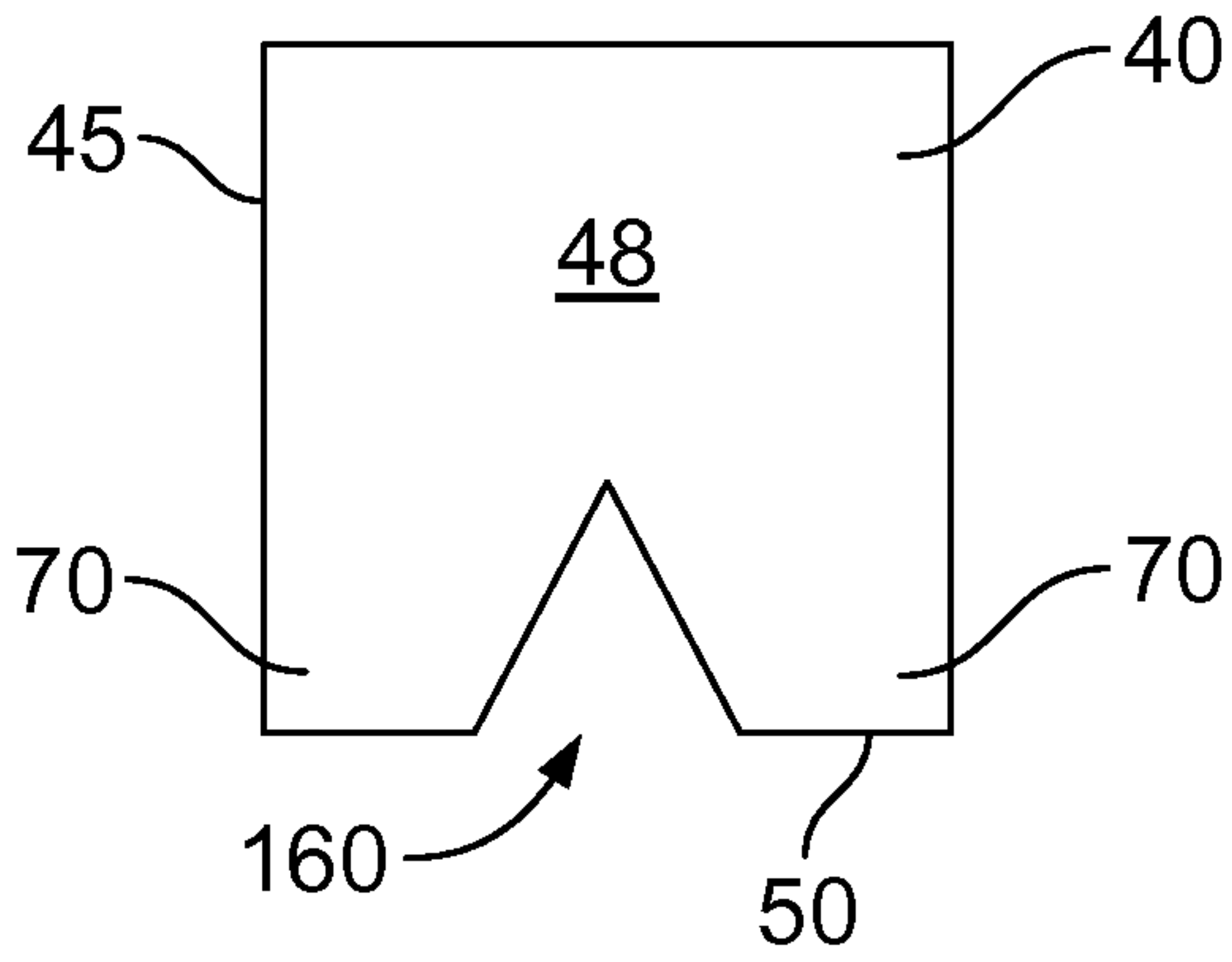

FIG. 9

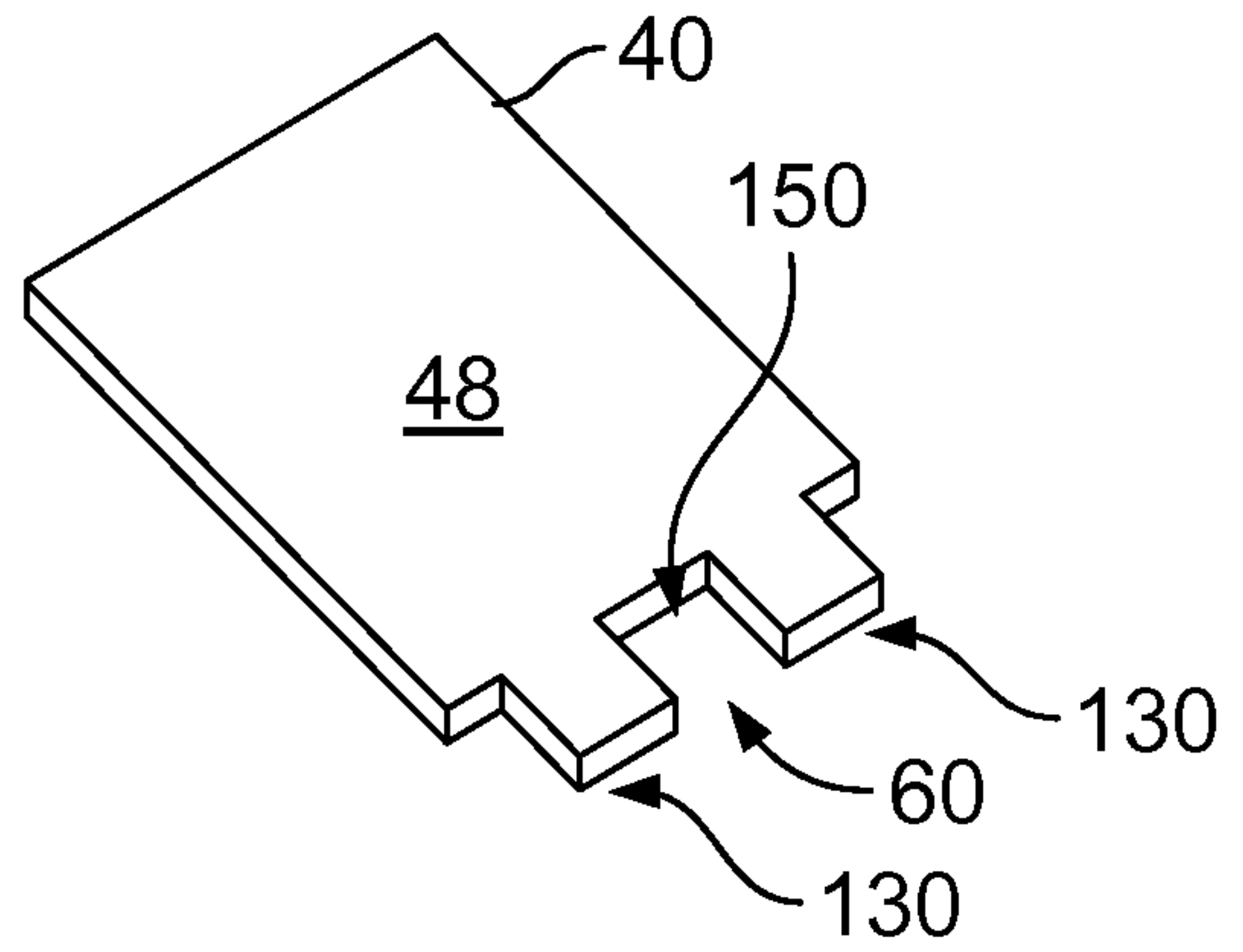

FIG. 10

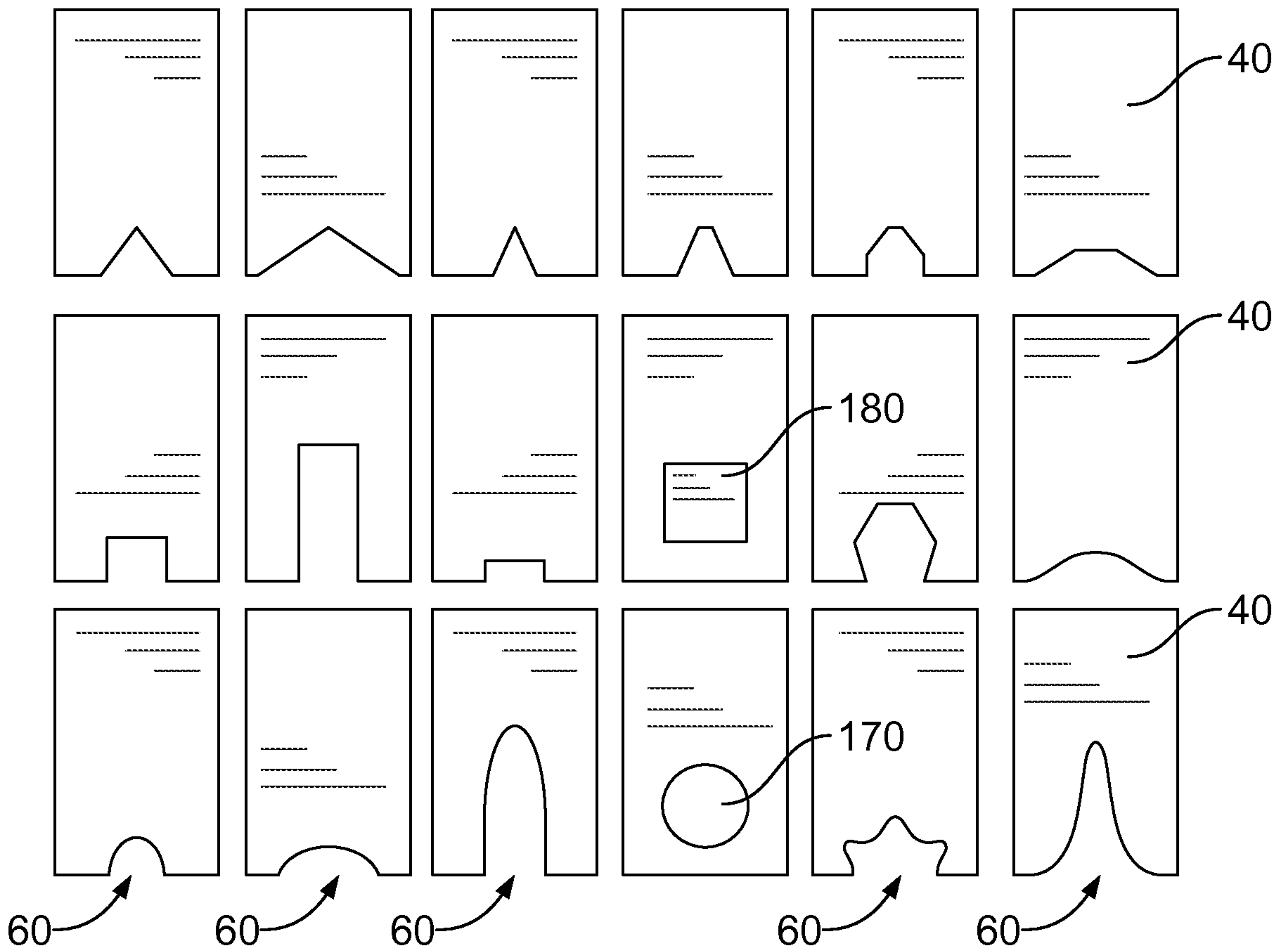

FIG. 11

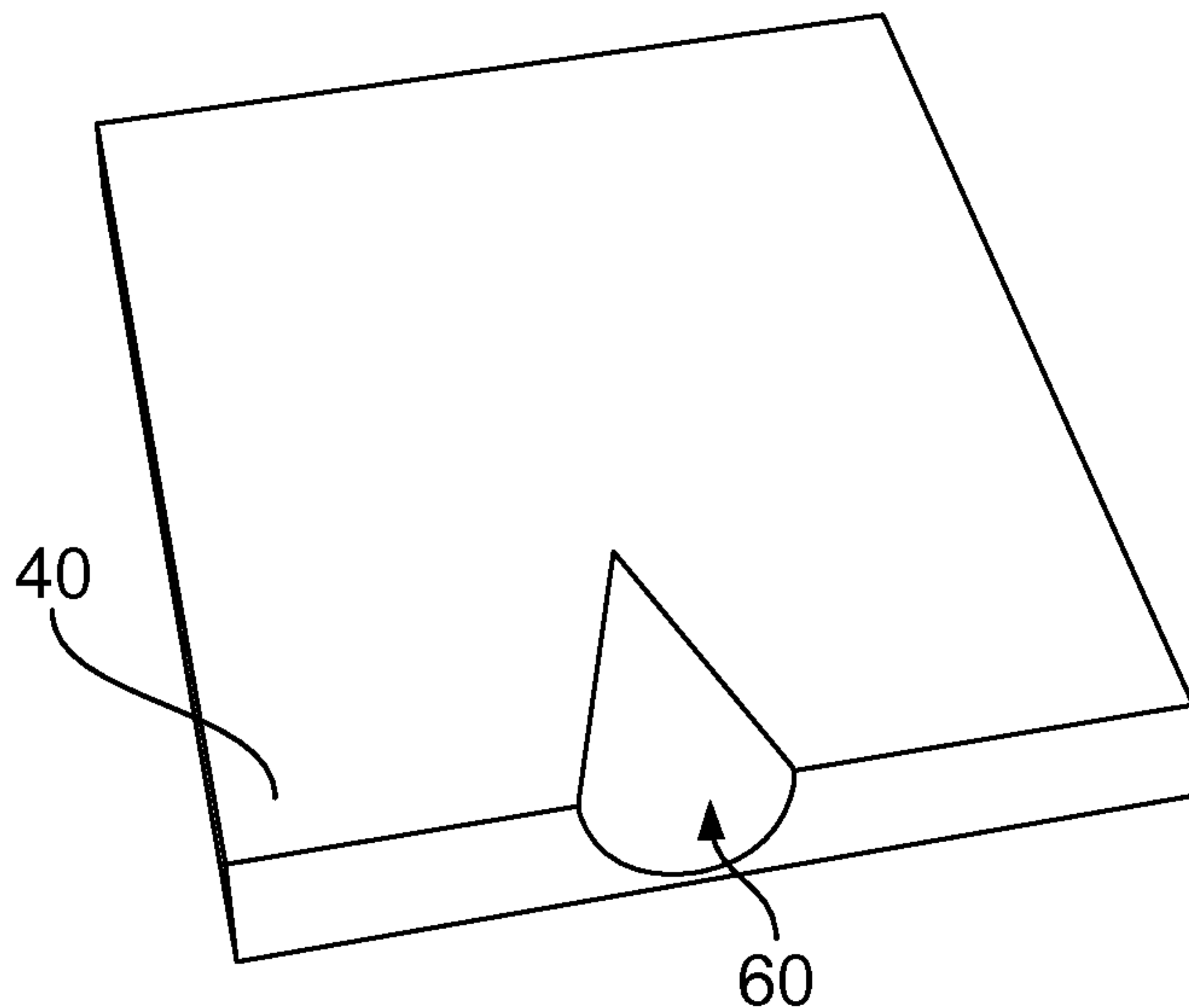

FIG. 12

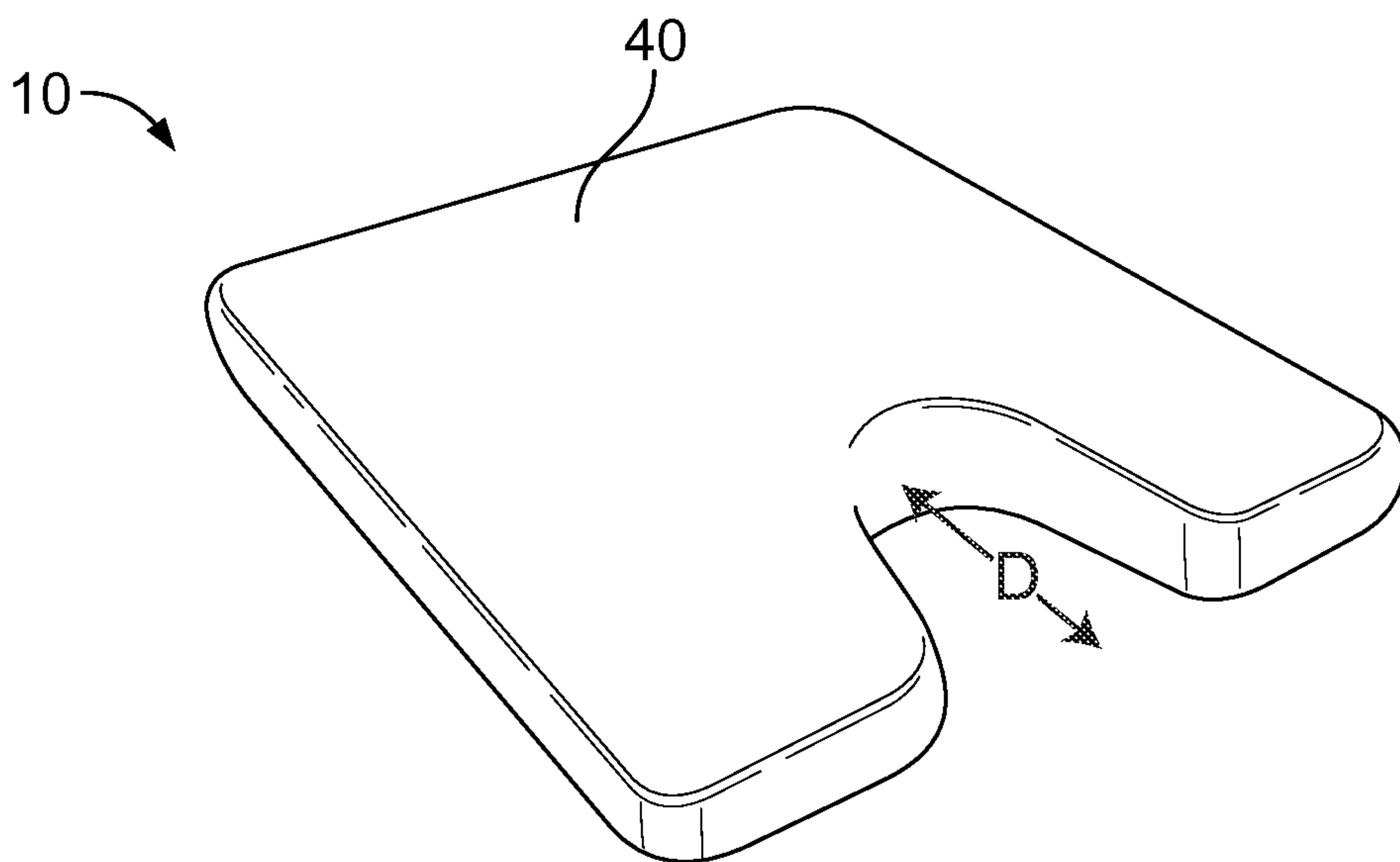

FIG. 13

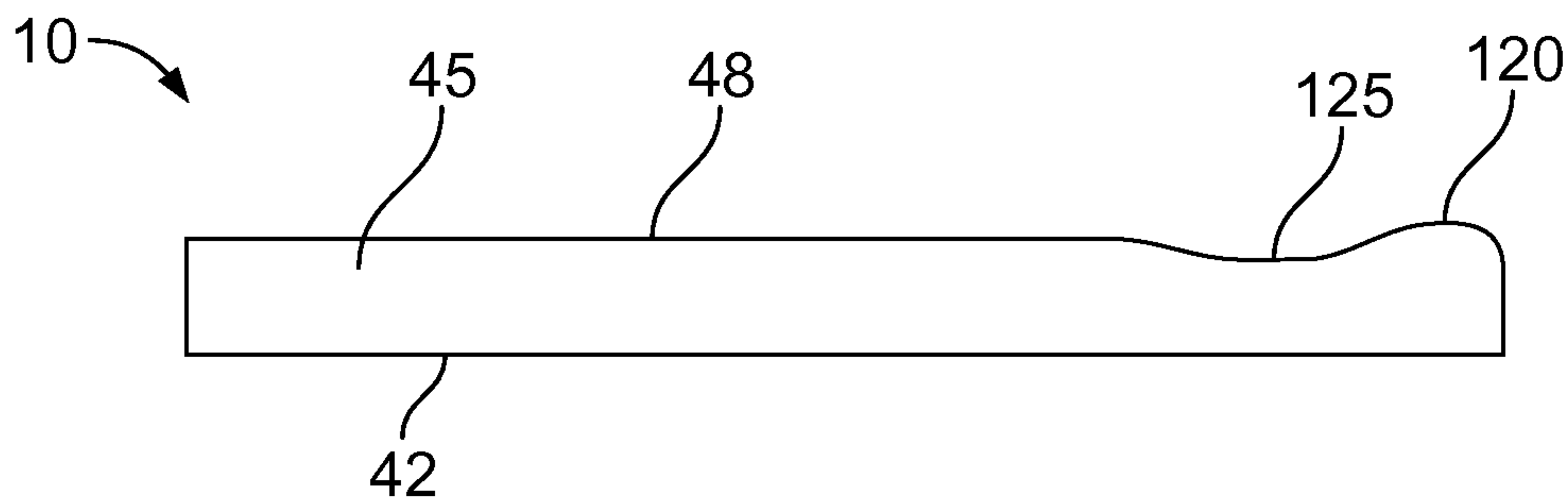

FIG. 14

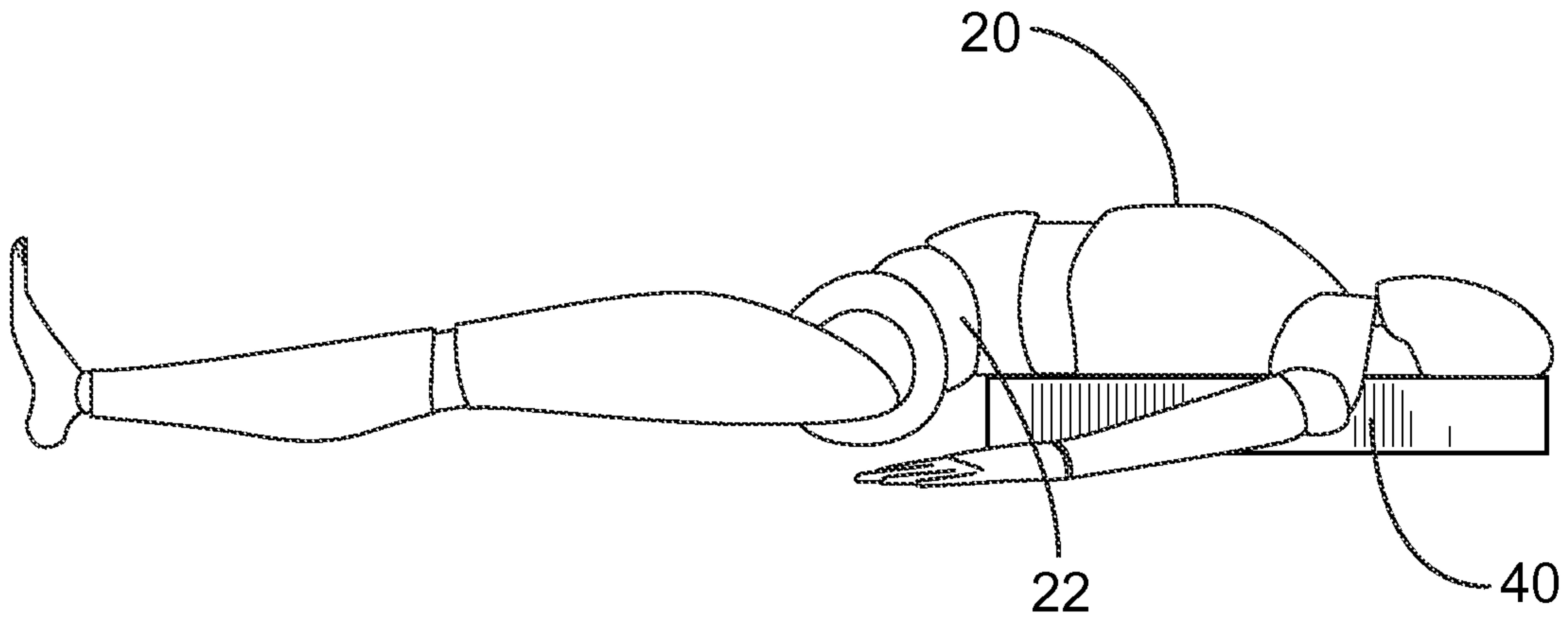

FIG. 15

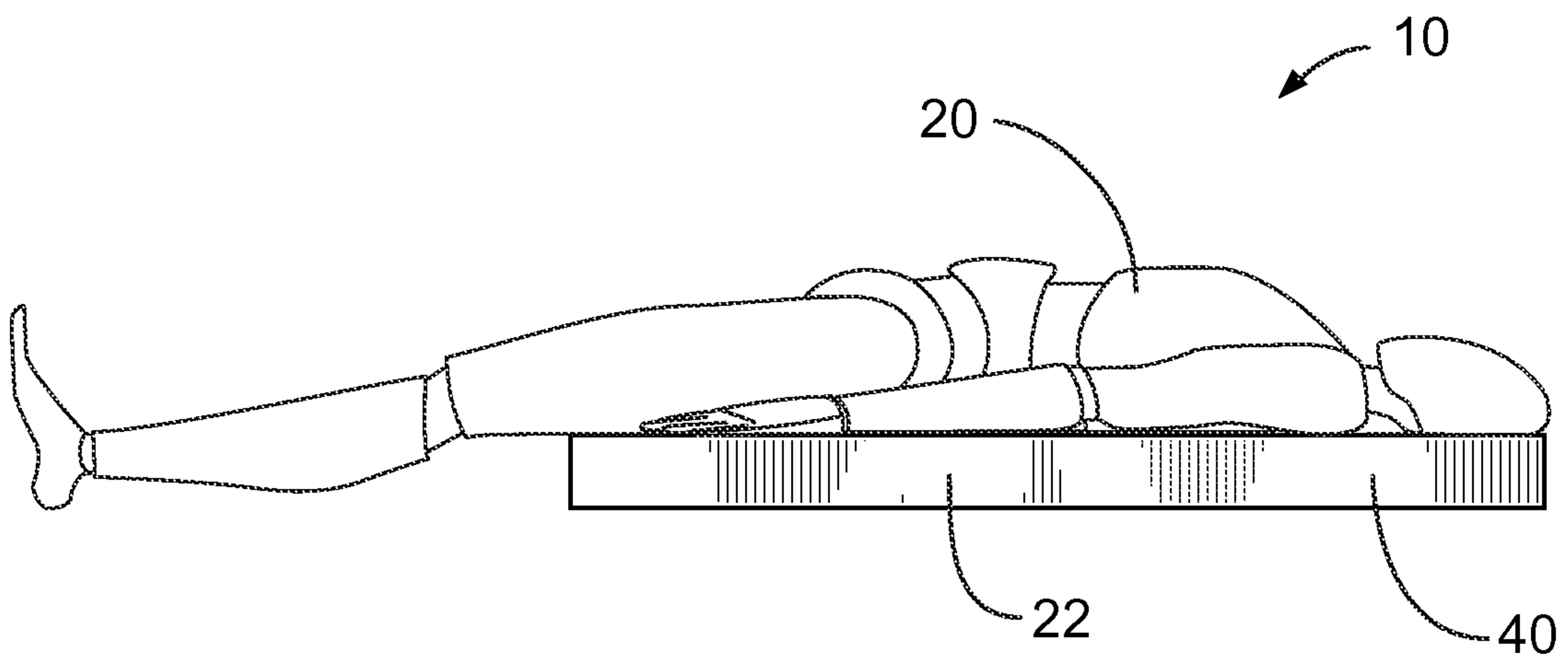

FIG. 16

