



Europäisches Patentamt  
European Patent Office  
Office européen des brevets



(11) **EP 1 588 021 B1**

(12) **EUROPEAN PATENT SPECIFICATION**

(45) Date of publication and mention  
of the grant of the patent:  
**02.08.2006 Bulletin 2006/31**

(51) Int Cl.:  
**E21B 29/00<sup>(2006.01)</sup> E21B 43/112<sup>(2006.01)</sup>**  
**E21B 44/04<sup>(2006.01)</sup>**

(21) Application number: **04701709.0**

(86) International application number:  
**PCT/NO2004/000005**

(22) Date of filing: **13.01.2004**

(87) International publication number:  
**WO 2004/063525 (29.07.2004 Gazette 2004/31)**

(54) **A METHOD AND DEVICE FOR DRILLING INTO TUBULARS LOCATED WITHIN ONE ANOTHER**

VERFAHREN UND VORRICHTUNG ZUM BOHREN VON IN INEINANDER ANGEORDNETEN  
ROHREN

PROCEDE ET DISPOSITIF DE PERFORATION D'ELEMENTS TUBULAIRES PLACES LES UNS A  
L'INTERIEUR DES AUTRES

(84) Designated Contracting States:  
**AT BE BG CH CY CZ DE DK EE ES FI FR GB GR  
HU IE IT LI LU MC NL PT RO SE SI SK TR**

(72) Inventor: **JOHANNESSEN, Tor, H.**  
**N-4046 Hafrsfjord (NO)**

(30) Priority: **13.01.2003 FI 20030149**

(74) Representative: **Lucas, Phillip Brian et al**  
**Lucas & Co.**  
**135 Westhall Road**  
**Warlingham, Surrey CR6 9HJ (GB)**

(43) Date of publication of application:  
**26.10.2005 Bulletin 2005/43**

(73) Proprietor: **Norse Cutting & Abandonment AS**  
**4056 Tananger (NO)**

(56) References cited:  
**EP-A1- 0 791 722 DE-A1- 19 924 200**  
**US-A- 4 619 556 US-A- 5 392 858**  
**US-A- 6 155 343 US-B1- 6 167 968**

**EP 1 588 021 B1**

Note: Within nine months from the publication of the mention of the grant of the European patent, any person may give notice to the European Patent Office of opposition to the European patent granted. Notice of opposition shall be filed in a written reasoned statement. It shall not be deemed to have been filed until the opposition fee has been paid. (Art. 99(1) European Patent Convention).

## Description

**[0001]** This invention relates to a method for drilling into tubulars which are located within one another. More specifically, it relates to a method for reducing drilling time when drilling through at least one pipe wall and there in an annulus within the pipe wall is a fluid or a material which in comparison to the pipe wall material is easier to drill. The invention also comprises a device for carrying out the method.

**[0002]** When removing for example composite casings for petroleum recovery, it has become customary to cut pipes by sawing. Often the pipe that has to be cut will contain one or more internal pipes. The annuli between the pipes may be filled with for example concrete.

**[0003]** If the internal pipes are insufficiently connected to the external pipe, the internal pipes may become displaced axially and/or radially in relation to the external pipe during the sawing operation. The displacement may cause damage to the sawing device that is being used.

**[0004]** It has therefore been deemed necessary to brace the internal pipes in relation to the external pipe before the actual sawing operation is initiated.

**[0005]** According to prior art one or more drilling devices are placed mainly in a radial direction on the casing surface of the external pipe. The drilling device may be hydraulically driven with regards to both rotation and feeding.

**[0006]** The drill bit of the drilling device is fed at a certain rate when rotating through the external pipe, the material located in the external annulus, and potentially further on through the pipe within, the next annulus and so on till the innermost pipe where the drill can be used for bracing by means of the feed power or for drilling through the pipe wall of the innermost pipe as well. Then, the drill may be used for bracing or it may be replaced with for instance a shaft to brace the pipes.

**[0007]** Due to the relatively long distance between the operating valves of the drilling device and the drill site, it is necessary to place the choke valve or constant pressure valve used for adjusting the feed speed of the drilling device near to the drilling device in order to overcome the flexibility of the pressure fluid pipe. There will only be restricted access to this valve during the drilling operation, as it may be dangerous for personnel to be in close proximity to the drilling device when it is operating.

**[0008]** Drilling operations in accordance with prior art take unnecessary long time because the drill is running at an approximately constant feed speed during the entire drilling operation.

**[0009]** The object of this invention is to remedy the disadvantages of the prior art.

**[0010]** The object is achieved according to the invention by means of the features disclosed in the description below and in the following patent claims.

**[0011]** Experience has shown that the drill bit can be fed at a significantly higher rate when it is working for example within concrete, compared to the feed speed

which is appropriate for drilling in the pipe wall material.

**[0012]** When the drill bit has cut through the first pipe wall, the rotational resistance in the drill bit is reduced, whereby the oil pressure in the hydraulic circuit for drill bit rotation is reduced. According to the invention, a valve for additional supply of hydraulic fluid to the feed cylinders of the drilling device is opened without disrupting the choke valve or constant pressure valve that is used to adjust the feed speed of the sawing device for drilling through the pipe wall material. Thus the drill is displaced fairly quickly through the concrete material and until the drill bit impacts the pipe wall located within. The rotational resistance of the drill is then increased, and a corresponding higher pressure can be read in the hydraulic circuit for drill bit rotation. The additional pressure fluid supply is shut off, whereby the drill bit continues to drill through the pipe wall material at the preset feed speed.

**[0013]** The method is repeated for any annuli and pipe walls located within.

**[0014]** By employing the method according to the invention, the drilling time for perforating pipes containing other pipes within can be significantly reduced. The method may contribute to considerable cost savings, as the hourly rates for this type of work, including hiring a drilling rig, are relatively high.

**[0015]** In the following, a non-limited example of a preferred method and embodiment is described and illustrated on the attached drawings, in which:

Figure 1 shows a cross section of a pipe assembly comprising a pipe with two pipes within it, where the annuli between the pipes are filled with concrete, and where two drilling devices are placed on the pipe and are about to drill holes in the pipe fitting;

Figure 2 shows a cross section I-I of the drilling device in Figure 1; and

Figure 3 shows a simplified hydraulic circuit diagram for the drilling device.

**[0016]** On the drawings, the reference number 1 denotes a drilling device provided with a drill bit 2 which is secured to an external tubular 6 by means of a fastening device 4.

**[0017]** Inside the external tubular 6 there is located an intermediate tubular 8, and inside the intermediate tubular 8 there is an internal tubular 10.

**[0018]** The spaces between the tubulars 6, 8 and 10 constitute an external annulus 12 and an internal annulus 14. The annuli 12 and 14 are filled with concrete.

**[0019]** In addition to the drill bit 2, the drilling device 1 comprises a feed rod 22 which is connected to the drill bit 2 by means of an adapter 20. The feed rod 22 is axially displaceable in the housing 24 of the drilling device 1 by means of two feed cylinders 26. The feed cylinders 26 are connected between the housing 24 and an axial bearing 28 placed around the feed rod 22. Two hydraulic driv-

ing motors 30 are connected to the housing 24 and encircle the feed rod 22 in an axially displaceable manner.

[0020] The drilling device 1 is controlled by means of a rotary valve 40 and a feed valve 42. The valves 40 and 42 are located at a safe distance from the drilling device 1 and supplied with pressure fluid from a hydraulic pump (not shown). From the rotary valve 40 hydraulic pipes 44 pass via quick release couplings 46 to the driving motors 30. A hydraulic feed line 48 connects the feed valve 42 via a quick release coupling 50 and a choke valve 52 to the feed side of the feed cylinders 26. The return side of the feed cylinders 26 is connected to the feed valve 42 by means of a hydraulic return line 54 and a quick release coupling 56.

[0021] A quick feed valve 58 is connected to the hydraulic feed line 48 at the feed valve 42. From the quick feed valve 58, a quick feed hydraulic line 60 passes via a quick release coupling 62 to the hydraulic feed line 48 in the area between the choke valve 52 and the feed cylinders 26. The quick release couplings 46, 50, 56 and 62 are arranged to facilitate the assembly of the drilling device 1.

[0022] The desired feed speed for the drill bit 2 is adjusted by regulating the choke valve 52, preferably before the drilling operations commence.

[0023] When a hole shall be drilled and the drilling device 1 is attached to the external tubular 6, the rotation of the drill bit 2 is initiated by setting the rotary valve 40 to operating position. Pressure fluid then flows through the rotary valve 40 and the driving motors 30 via the hydraulic lines 44 and the quick release couplings 46. The driving motors 30 rotate the feed rod 22 and thus the drill bit 2 around its own longitudinal axis.

[0024] The feeding of the drill bit 2 is initiated by setting the feed valve 42 to its feeding position. By doing so, pressure fluid flows from the feed valve 42 via the hydraulic feed line 48, the quick release coupling 50 and the choke valve 42 to the feed side of the feed cylinders, as the feed cylinders displace the axial bearing 28 and thus the feed rod 22 and the drill bit 2 in a direction in and towards the external tubular 6.

[0025] It is necessary to place the choke valve 52 near to the feed cylinders 26 because otherwise the elasticity of the hydraulic feed line 48 could cause an irregular feed speed.

[0026] After the drill bit 2 has worked its way through the pipe wall of the external tubular 6, cf. the drill bit 2 belonging to the top drilling device 1 in figure 1, the momentum needed to rotate the drill bit 2 is reduced because the concrete located in the external annulus 12 is easier to drill than the wall of the tubular 6. The rotational fluid pressure, which can be read on a manometer 64, is reduced correspondingly.

[0027] By opening the quick feed valve 58, pressure fluid flows to the feed side of the feed cylinders 26 through the hydraulic quick feed line 60 and the quick release coupling 62 bypassing the choke valve 52. Thus, the drill bit 2 is fed quicker through the concrete in the external

annulus 12, cf. the drill bit 2 belonging to the lower drilling device in figure 1. When the drill bit 2 has reached the intermediate tubular 8, the rotational resistance in the drill bit 2 is increased. The corresponding increase in pressure can be read from the manometer 64. The quick feed valve 58 is shut, whereby the feed speed of the drill bit 2 through the pipe wall of the intermediate tubular 8 is reduced to the preset value on the choke valve 52.

[0028] Correspondingly, the feed speed is increased when drilling through the internal annulus 14 and possibly through the annulus of the internal pipe 10.

### Claims

1. A method for a drilling device (1) to increase the feed speed of a drill bit (2) when drilling through tubulars (6, 8, 10) located within one another, where a fluid or a material is located in the annuli (12, 14) created between the tubulars (6, 8, 10), which in comparison to the pipe wall material, is easier to drill, and where the feed speed of the drill bit (2) is controlled by a pressure fluid regulating valve (52) which preferably is located near to the drilling device (1), **characterised in that** during the progress of the drill bit (2) through the annulus (12, 14) there is an influx of pressure fluid in parallel with the pressure fluid regulating valve (52).
2. A method according to claim 1, **characterised in that** the influx of pressure fluid is initiated by opening a valve (58) which is located at a safe distance from the drilling device (1).
3. A device for a drilling device to increase the feed speed of a drill bit (2) when drilling through tubulars (6, 8, 10) located within one another and under water, where a fluid or a material is located in the annulus (12, 14) created between the tubulars (6, 8, 10), which in comparison to the pipe wall material, is easier to drill, and where the feed speed of the drill bit (2) is controlled by a pressure fluid regulating valve (52) which is connected to a hydraulic feed line (48) and where the hydraulic feed line (48) passes from a feed valve (40) to a feed cylinder (26), as the pressure fluid regulating valve (52) preferably is located close to the drilling device (1), **characterised in that** there passes a hydraulic quick feed line (60) in parallel with and connected to the hydraulic feed line (48) above and underneath the pressure fluid regulating valve (52), which is provided with a block valve (58).
4. A device according to claim 3, **characterised in that** the block valve (58) is placed at a safe distance from the drilling device (1).

## Patentansprüche

1. Verfahren für eine Bohrvorrichtung (1) zum Erhöhen der Zufuhrgeschwindigkeit einer Bohrspitze (2) beim Bohren durch ineinander angeordnete Rohre (6, 8, 10), in den zwischen den Rohren erzeugten Ringen (12, 14) befindet sich ein Fluid oder Material, welches im Vergleich zum Rohrwandmaterial leichter zu bohren ist, die Zufuhrgeschwindigkeit der Bohrspitze (2) wird durch ein vorzugsweise benachbart der Bohrvorrichtung (2) angeordnetes Fluiddruckregelventil (52) gesteuert, **dadurch gekennzeichnet, dass** während des Vortriebs der Bohrspitze (2) durch die Ringe (12, 14) ein Zustrom von Druckfluid parallel zum Fluiddruckregelventil (52) erfolgt. 5
2. Verfahren nach Anspruch 1, **dadurch gekennzeichnet, dass** der Zustrom von Druckfluid durch Öffnen eines in sicherer Entfernung von der Bohrvorrichtung (1) angeordneten Ventils (58) eingeleitet wird. 10
3. Vorrichtung für eine Bohrvorrichtung (1) zum Erhöhen der Zufuhrgeschwindigkeit einer Bohrspitze (2) beim Bohren durch ineinander angeordnete Rohre (6, 8, 10), in den zwischen den Rohren erzeugten Ringen (12, 14) befindet sich ein Fluid oder Material, welches im Vergleich zum Rohrwandmaterial leichter zu bohren ist, die Zufuhrgeschwindigkeit der Bohrspitze (2) wird durch ein mit einer Hydraulik-Speiseleitung (48) verbundenes Fluiddruckregelventil (52) gesteuert, wobei die Hydraulik-Zufuhrleitung (48) von einem Speiseventil (42) zu einem Zufuhrzylinder (26) verläuft, und wobei das Fluiddruckregelventil (52) vorzugsweise benachbart der Bohrvorrichtung (2) angeordnet ist, **dadurch gekennzeichnet, dass** eine mit einem Absperrventil (58) versehene, parallel zur Hydraulik-Zufuhrleitung (48) verlaufende und oberhalb und unterhalb des Fluiddruckregelventils (52) mit dieser verbundene Hydraulik-Schnellzufuhrleitung (60) vorgesehen ist. 15  
20  
25  
30  
35  
40
4. Vorrichtung nach Anspruch 3, **dadurch gekennzeichnet, dass** das Absperrventil (58) in sicherer Entfernung von der Bohrvorrichtung (1) angeordnet ist. 45

paroi des tubes, et dans lequel la vitesse d'avance du foret (2) est réglée par une vanne de régulation de fluide sous pression (52) qui est de préférence placée près de l'appareil de perçage (1), **caractérisé en ce que**, pendant la progression du foret (2) à travers les espaces annulaires (12, 14), il y a une admission de fluide sous pression en parallèle avec la vanne de régulation de fluide sous pression (52).

2. Procédé selon la revendication 1, **caractérisé en ce que** l'admission de fluide sous pression est démarrée par ouverture d'une vanne (58) qui est placée à une distance de sécurité de l'appareil de perçage (1).

3. Dispositif pour appareil de perçage, pour augmenter la vitesse d'avance d'un foret (2) lors du perçage à travers des éléments tubulaires (6, 8, 10) placés à l'intérieur les uns des autres et sous l'eau, lorsqu'un fluide ou une matière est placé dans les espaces annulaires (12, 14) définis entre les éléments tubulaires (6, 8, 10), cette matière étant plus facile à percer comparativement à la matière de la paroi des tubes, et dans lequel la vitesse d'avance du foret (2) est réglée par une vanne de régulation de fluide sous pression (52) qui est connectée à une ligne d'alimentation hydraulique (48) et la ligne d'alimentation hydraulique (48) va d'une vanne d'alimentation (40) à un vérin d'avance (26), la vanne de régulation de fluide sous pression (52) étant de préférence placée près de l'appareil de perçage (1), **caractérisé en ce qu'**une ligne d'alimentation hydraulique rapide (60) passe en parallèle avec la ligne d'alimentation hydraulique (48) et est raccordée à celle-ci au-dessus et au-dessous de la vanne de régulation de fluide sous pression (52), et la ligne d'alimentation hydraulique rapide (60) est pourvue d'une vanne d'arrêt (58).

4. Dispositif selon la revendication 3, **caractérisé en ce que** la vanne d'arrêt (58) est placée à une distance de sécurité de l'appareil de perçage (1).

## Revendications

1. Procédé concernant un appareil de perçage (1) pour augmenter la vitesse d'avance d'un foret (2) lors du perçage à travers des éléments tubulaires (6, 8, 10) placés les uns à l'intérieur des autres, lorsqu'un fluide ou une matière est placé dans les espaces annulaires (12, 14) définis entre les éléments tubulaires (6, 8, 10), le dit fluide ou la dite matière étant plus facile à percer comparativement à la matière de la 50  
55

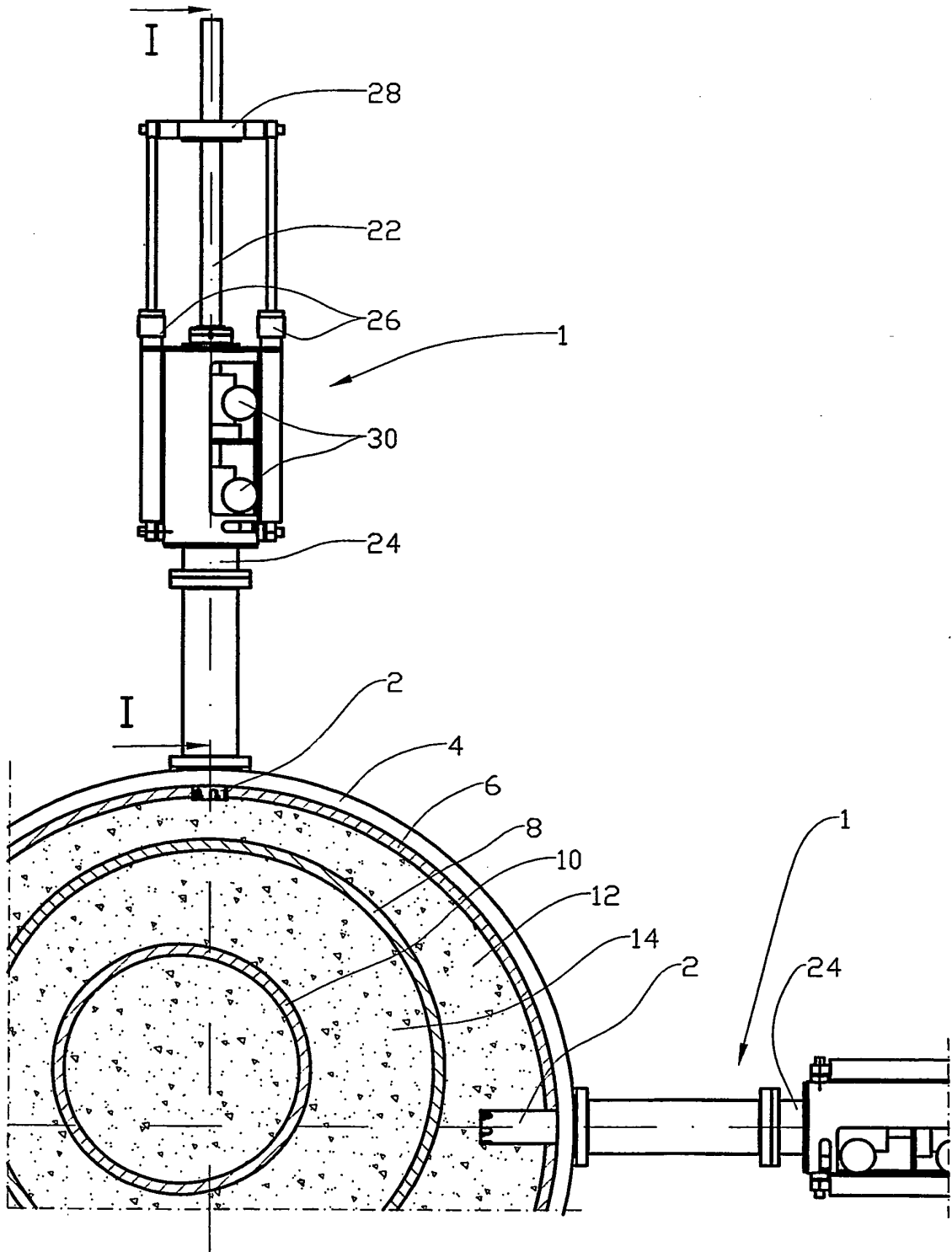
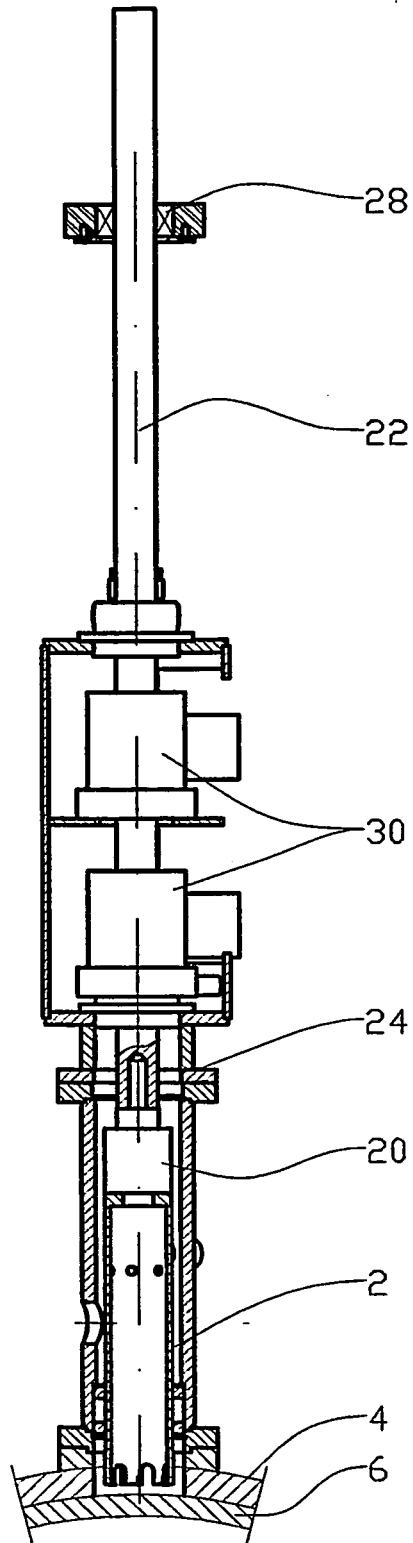

Fig. 1



I-I

Fig. 2

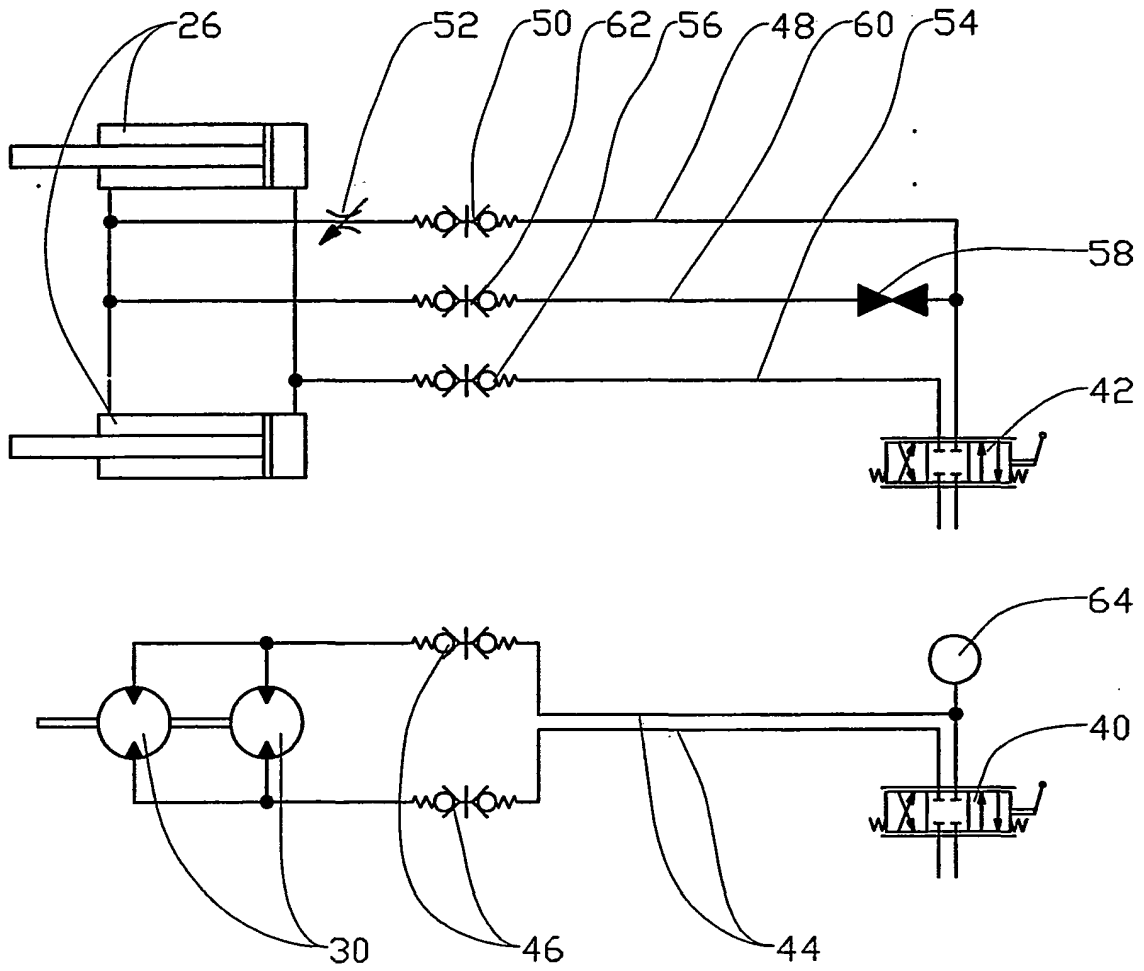

Fig. 3