

(19) **DANMARK**

(10) **DK/EP 2871302 T3**



(12) **Oversættelse af  
europæisk patentskrift**

Patent- og  
Varemærkestyrelsen

- 
- (51) Int.Cl.: **E 04 G 5/14 (2006.01)** **E 04 G 21/32 (2006.01)**
- (45) Oversættelsen bekendtgjort den: **2017-03-20**
- (80) Dato for Den Europæiske Patentmyndigheds bekendtgørelse om meddelelse af patentet: **2016-12-14**
- (86) Europæisk ansøgning nr.: **13192171.0**
- (86) Europæisk indleveringsdag: **2013-11-08**
- (87) Den europæiske ansøgnings publiceringsdag: **2015-05-13**
- (84) Designerede stater: **AL AT BE BG CH CY CZ DE DK EE ES FI FR GB GR HR HU IE IS IT LI LT LU LV MC MK MT NL NO PL PT RO RS SE SI SK SM TR**
- (73) Patenthaver: **Safety Solutions Jonsereds AB, Lägervägen 3, 832 96 Frösön, Sverige**
- (72) Opfinder: **Cooper, Paul, Övre Gräftevägen 19, 835 94 Aspås, Sverige**
- (74) Fuldmægtig i Danmark: **Awapatent A/S, Strandgade 56, 1401 København K, Danmark**
- (54) Benævnelse: **Monteringsindretning til et midlertidigt kantafskærmningssystem.**
- (56) Fremdragne publikationer:  
**GB-A- 2 336 391**  
**US-A- 3 734 467**



# **DESCRIPTION**

## **FIELD OF THE INVENTION**

**[0001]** The present invention relates to a mounting arrangement for a temporary edge protection system comprising posts and edge protection members mountable at the posts, wherein the mounting arrangement comprises a holder for edge protection members.

## **BACKGROUND OF THE INVENTION**

**[0002]** Temporary edge protection systems are used for protecting workers on buildings under construction or renovation from falling off or within the building. There are many different temporary edge protection systems in use today. A temporary edge protection system generally comprises edge protection members, such as barrier panels, or rails, posts, post holders to arrange the posts on the base, such as a floor, a concrete slab, or some other structure of the building, and holders for edge protection members, which below will also be called panel holders, although they can be arranged for holding other kinds of edge protection members than panels.

**[0003]** When mounting a temporary edge protection system at a building it is often desirable to use different kinds of edge protection members at different locations of the building. For instance barrier panels at the edges of floors, rails in stairs, and at low heights, etc. In the present systems the holders for the edge protection members are tailor made for a special kind of edge protection member, and therefore, several different types of holders are needed. The same is generally true for other parts of the systems, i.e. they only work with a particular type of connectible device. Alternatively, the holders for edge protection members are most simple, such as open L-shaped hooks. It is true that such a hook, made with a wide enough opening, can receive different kinds of edge protection members, but it is a disadvantage that they are not being fixed but are just loosely supported.

**[0004]** GB 2 336 391 A discloses a mounting arrangement according to the preamble of claim 1.

## **SUMMARY OF THE INVENTION**

**[0005]** It would be advantageous to provide an adaptable temporary edge protection system.

**[0006]** To better address this concern, in a first aspect of the invention there is presented an arrangement for a temporary edge protection system, as defined in claim 1, comprising posts and edge protection members mountable at the posts, the arrangement comprising a panel holder comprising an elongated post slider, movably arrangeable at a post to extend in parallel with the post, and two panel supports, attached to the post slider at a distance from each other. Each panel support comprises a horizontal elongated support portion, defining a longitudinal direction, on which the edge protection members are to rest, an adjustable clamping element comprising a vertical tongue portion arranged to clamp the edge protection members against a clamp surface of the post slider and an adjustment element arranged to change the distance between the clamping element and the post slider in the longitudinal direction of said support portion, thereby providing clamping of the edge protection members against the clamp surface of the post slider. By means of this adjustable panel holder the system becomes more flexible than the prior art systems having fixed or specially shaped panel holders, such as fixed hooks, loops, clamps, or the like, which are adapted to hold a particularly shaped panel, rail, etc.

**[0007]** In accordance with an embodiment of the arrangement the post slider comprises an elongated guide portion, and upper and lower post engagement portions respectively arranged at top and bottom end portions of the guide portion.

**[0008]** In accordance with an embodiment the support portion is comprised in the clamping element, the tongue portion is attached to the support portion, and the support portion is longitudinally displaceably connected with the post engagement portion.

**[0009]** In accordance with an embodiment of the arrangement, the support portion is channel shaped, having its opening turned sideways towards a wall of the post engagement portion, wherein the post engagement portion comprises an adjustment element holder, which is attached to said wall and received in the support portion, wherein the adjustment element is engaged with the

adjustment element holder such that the adjustment element displaces the support portion relative to the adjustment element holder when operated.

[0010] In accordance with an embodiment of the arrangement, the adjustment element is a screw and the adjustment element holder is a sleeve being in threaded engagement with the screw.

[0011] In accordance with an embodiment of the arrangement the support portion comprises an elongated, generally U-shaped bracket, which is attached to the post slider at the open end of the bracket, wherein the bracket protrudes from the post slider, the legs of the bracket being substantially longer than its width.

[0012] In accordance with an embodiment of the arrangement the adjustment element is a screw extending within the bracket, wherein the screw is rotatable and has a fixed longitudinal position. The clamping element is engaged with threads of the screw, and is prevented from rotating by the legs of the bracket, thereby moving along the screw when the screw is rotated. Thereby many different kinds of edge protection members, and combinations thereof can be clamped by means of the clamping device.

[0013] In accordance with an embodiment of the mounting arrangement it further comprises a post holder arranged to be provided on a base, wherein the post holder comprises a post tightening assembly. It should be noted that typically a post has some kind of snap lock, which prevents it from being demounted from the post holder by simply pulling it upwards. However, a certain play is typically at hand between the post and the post holder, in order to make it easy to mount and demount the post. The post tightening assembly removes that play.

[0014] In accordance with an embodiment of the arrangement the post tightening assembly comprises a movable element and a fixed element, wherein the movable element is arranged to exert a tightening force on a surface of the post when moved to a tightening position, wherein the movable element constitutes a filling piece between the fixed element and the surface, and wherein at least one of the movable element and the fixed element comprises a guide surface, which is inclined relative to the surface of the post.

[0015] In accordance with an embodiment of the mounting arrangement the post holder comprises an elongated vertical post retaining portion, and a base support portion protruding laterally from the post retaining portion, wherein the post retaining portion comprises a post reception channel defined by a bottom wall, and opposite side walls raising from the bottom walls, the side walls having an J-shaped cross-section.

[0016] In accordance with an embodiment of the mounting arrangement the fixed element comprises an inclined portion extending inside of the channel at a top end portion thereof.

[0017] In accordance with an embodiment of the mounting arrangement the guide portion is plate shaped and arranged to be received in a groove of the post.

[0018] In accordance with an aspect of the present invention, there is provided a temporary edge protection system comprising edge protection members, posts, and the above-described mounting arrangement.

## **BRIEF DESCRIPTION OF THE DRAWINGS**

[0019] The invention will now be described in more detail and with reference to the appended drawings in which:

Figs. 1 and 2 are perspective views of an embodiment of the temporary edge protection system according to the present invention, in an assembled state;

Fig. 3 shows enlarged details of the edge protection system of Fig. 1;

Figs. 4 and 5 are perspective views of an embodiment of a panel holder according to this invention;

Fig. 6 is a partly cut-away view of a part of the panel holder of Fig. 4;

Figs. 7 and 8 are perspective views of an embodiment of a post holder according to this invention;

Fig. 9 is a longitudinally sectional view of the post holder in Fig. 7;

Fig. 10 is a perspective view of the panel holder in Fig. 4 in a mounted state; and

Fig. 11 is a perspective view of another embodiment of a panel holder according to this invention.

## **DESCRIPTION OF EMBODIMENTS**

**[0020]** According to an embodiment of the temporary edge protection system 1, as shown in Figs. 1, 2 and 3 it comprises barrier panels 2, 3, 4, posts 5, panel holders 6 adjustably mountable on the posts 5, and post holders 7. The post holders 7 are arranged on a base 8, such as a floor, a concrete slab, or some other structure of a building. The temporary edge protection system 1 is arranged close to the edge of the base, often several floors up, i.e. tens of meters above ground. There are different standards stating the requirements that the edge protection system must fulfill in order to be allowed for a particular use. For flat surfaces, and/or close to the ground, the requirements are of course lower than for sloping bases and/or high heights. Other parameters have an influence as well. The present edge protection system 1 is easily adaptable to the requirement of different standards due to its flexibility. For the users the weight of the system parts is an important factor, since they often assemble several hundreds of system parts during a working day. Therefore it is not optimal to provide one single embodiment which qualifies for the highest standard, since it becomes unnecessarily heavy for use in large volumes of lower standard applications.

**[0021]** According to the illustrated embodiment, the barrier panels 2-4, which are most cumbersome to handle, and the weight of which is particularly important, are made flexible to be easily adaptable to different standards, and applications. Furthermore, aluminum has been applied to a high extent for manufacturing different parts of the system. However, even plastics has been found usable to some extent, such as for toe boards 28. In addition to barrier panels 2-4, rails 9, such as wooden boards, are used.

**[0022]** In order to support the flexibility of the system while keeping the number of parts down, according to this invention adjustable panel supports 6 are provided. One embodiment thereof is shown in Figs. 4-6, and another embodiment thereof is shown in Fig. 10. The panel holder 6 is capable of supporting many different kinds of edge protection members, such as the barrier panels 2-4, more particularly horizontal aluminum bars 10, 12 thereof, the rails 9, and any combination of them, from a single bar 10, 12, which is the thinnest alternative, to two rails 9, which is the thickest alternative of these edge protection members. Hence, the first embodiment of the panel holder 6 comprises a post slider 40, movably arrangeable at a post 5 to extend in parallel with the post, and arranged to be locked in an arbitrary position along the post 5. The post slider 40 comprises an elongated guide portion 41, and upper and lower post engagement portions 43, 44, respectively arranged at top and bottom end portions 45, 46 of the guide portion 41. The guide portion 41 is plate shaped and is arranged to be received in a groove 85, which extends along the length of the post 5 at one side thereof. More particularly, the post 5 is rectangular in cross-section and has a longitudinal flange 86 at each of its corners, see Fig. 10. The flanges 86 are arranged in pairs at opposite sides of the post 5, and protrude from a base surface 87 of the post, thereby defining the groove 85 between them. In other words the post 5 has two opposite grooves 85, at opposite sides of the post 5.

**[0023]** Each one of the upper and lower post engagement portions 43, 44 extends around the post when mounted, and comprises a respective channel portion 55, 56 generally U-shaped in cross-section, which is for instance obtained by bending a plate. Thus, referring to the upper channel portion 55, it has three walls; a base wall 57, and first and second side walls 58, 59, which are opposite to each other. Furthermore, it comprises a locking element 60, which is engaged with the side walls 58, 59, and is arranged to clamp them towards each other, and thus clamp the post 5 between them, to thereby lock the panel holder 6 in the chosen position. Like in this embodiment the locking element 60 can simply be a screw extending through holes of the first and second side walls 58, 59 and through a nut 66 attached to the second wall 59 in alignment with the hole. The lower channel portion 56 is similar to the upper channel portion 55, having a base wall 61 and side walls 62, 63, but instead of having a locking element connecting the side walls 62, 63, it has a general connection element 64 just closing the opening between the side walls 62, 63, since it has appeared that the upper locking element generates enough locking force to prevent the panel holder 6 from moving unintentionally.

**[0024]** The top and bottom end portions 45, 46 of the guide portion 41 are attached to the inner side of the respective first side wall 58, 59 of the upper and lower channel portions 55, 56.

**[0025]** Two panel supports 47, 48 are connected with the post slider 40 at a distance from each other. More particularly, the panel supports 47, 48 are connected with the upper and lower post engagement portions 43, 44, respectively. Each panel support 47, 48 comprises an adjustable clamping element 49, 50 and an adjustment element 51, 52 arranged to change the distance between the clamping element 49, 50 and the post slider 40. Each clamping element 49, 50 comprises a horizontal

elongated support portion 91, 92, on which the barrier panels/rails 2-4, 9 are to rest, and a vertical tongue portion 93, 94 arranged to clamp the barrier panels/rails against the post slider 40. The vertical tongue 93, 94 is attached to one end of the support portion 91, 92. The support portion 91, 92 is longitudinally displaceably connected with the post engagement portion 43, 44. The support portion 91, 92 is channel shaped, having its opening turned sideways towards the first wall 58, 62 of the channel portion 55, 56. Each one of the upper and lower post engagement portions 43, 44 comprises a panel clamping surface 53, 54 positioned opposite of the tongue portion 93, 94 of the clamping element 49, 50, and the barrier panels/rails are clamped between them by operating the adjustment element 51, 52 for displacing the clamping element 49, 50 relative to the post engagement portion 43, 44.

**[0026]** In this embodiment, the adjustment element of each panel support 47, 48 is a screw, which is rotationally connected with the support portion 91, 92, and is in threaded engagement with a sleeve 95, 96 which is comprised in the post engagement portion 43, 44. The post engagement portion 43, 44 comprises an angle bar 97, 98 attached to the first side wall 58, 62 at the outside thereof. The angle bar 97, 98 includes a vertical wall portion containing the clamp surface 53, 54, which is placed adjacent to the base wall 57, 61 and extends in the same plane as the base wall, and a bottom plate portion 99, 100 extending perpendicular to the clamp surface 53, 54. The sleeve 95 is attached to the outside of the first wall 58, 62, and the support portion 91, 92 extends adjacent to and in parallel with the first side wall 58, 62. The sleeve 95, 96 is received in the groove formed by the walls of the support portion 91, 92. The screw 51, 52 is longitudinally fixed relative to the support portion 91, 92, and extends along the full length of the support portion 91, 92. Thus, when the screw 51, 52 is operated it brings the clamping element 49, 50 along with it, while the support portion 91, 92 is displaced relative to the sleeve 95, 96. The support portion 91, 92 can be regarded to slide along the sleeve 95, 96. Thereby the distance between the tongue portion 93, 94 and the clamp surface 53, 54 of the post engagement portion 43, 44 is adjusted.

**[0027]** Thus, when mounting the temporary edge protection, the panel holder 6 is mounted on a post 5 by slipping the post engagement portions 43, 44 onto the post 5 from one end thereof, such that the guide element 41 is received in a corresponding groove 85 extending along the post 5. Then the panel holder 6 is moved to the desired position along the post 5, and the locking element 60 is tightened. The barrier panel(s) and/or rail(s) are placed on the panel supports 47, 48, i.e. they are received in the space between the clamping elements 49, 50 and the panel clamping surfaces 53, 54. Then the adjustment elements 51, 52 are operated to fix the barrier panels/rails by reducing the space and thus clamp the barrier panels/rails between the clamping elements 49, 50 and the post slider 40.

**[0028]** According to another embodiment of the panel holder 110, as shown in Fig. 11, similar to the above embodiment, it comprises a post slider 111, having an elongated guide portion 112 and upper and lower post engagement portions 113, 114 arranged at end portions of the guide portion 112; and upper and lower panel supports 115, 116 connected with a respective one of the post engagement portions 113, 114. However, each panel support 115, 116 has a support portion that comprises a bracket 117, 118, on which the barrier panels/rails are to rest. The bracket 117, 118 is attached to and protrudes from the base wall 119, 120 of the channel portion 121, 122 of the post engagement portion 113, 114. In other words, the panel supports 115, 116 are in line with the channel portions 121, 122, instead of beside them like in the above embodiment. Thereby the panel holder 110 becomes narrower. On the other hand, in the above embodiment of the panel holder 6, the protrusion inwards of the temporary edge protection system, counted from the inner most surface of the barrier panels, is minimized, since the clamping element, which includes the support portion in that embodiment, is displaced when clamping, while in this alternative embodiment the fixed bracket 117, 118 of the support portion will protrude more if the barrier panels are thin than if they are thick. The legs of the bracket 117, 118 are substantially longer than its width. The panel holder comprises an adjustment element 123, 124, which is a screw extending within the bracket 117, 118. The screw 123, 124 is rotatable and has a fixed longitudinal position, by extending through a hole of the bracket portion 125, 126 joining the legs at the outer ends thereof, and a hole of an opposite cross wall 127, 128 extending between the legs close to the base wall 119, 120 of the post slider 112, and having a screw head and a fixed nut at its respective ends. The adjustable clamping element 129, 130 constitutes a vertical tongue portion arranged within the bracket 117, 118 and engaged with the threads of the screw 123, 124. The clamping element 129, 130 is prevented from rotating by the legs of the bracket 117, 118, thereby moving along the screw 123, 124 when the screw is rotated. The barrier panels/rails are clamped between the clamping element 129, 130 and the base wall 119, 120, providing a clamp surface.

**[0029]** In accordance with an embodiment of the mounting arrangement it further comprises a post holder 7 arranged to be provided on the base 8. The post holder 7 comprises an elongated vertical post retaining portion 67, and a base support portion 68 protruding horizontally from the post retaining portion 67, and arranged to rest on the base 8. The post retaining portion 67 is generally channel-shaped and has a bottom wall 80, and opposite side walls 81 raising from the bottom wall 80, the side walls 81 having a J-shaped cross-section. Thus, when the post 5 is in a mounted state, the edges of the side walls 81 are engaged with two flanges 86, a portion of the post 5 thus extending through the post retaining portion 67. The post 5 has a snap lock device 71, which comprises a spring biased locking pin 72, which is received in a recess 73 of the post holder when the post 5 is in the mounted state.

[0030] This kind of post shape and connection of the post holder 7 and the post 5 is advantageous in that the opposite side of the post, having a similar groove shape, is free to use in the full length of the post for connecting other parts.

[0031] Furthermore, the post holder 7 comprises a post tightening assembly 70. The post tightening assembly 70 comprises a movable element 74 and a fixed element 75, wherein the movable element 74 is arranged to exert a tightening force on a surface 76 of the post 5 when moved to a tightening position. The surface 76 extends between the flanges 86 that the side wall edges of the post holder 7 are engaged with. It should be noted that this post surface 76 is typically opposite to the above mentioned post surface 63 facing the panel holder 6. That is, the post holder 7 and the panel holder 6 are mounted on opposite sides of the post 5. The movable element 74 constitutes a filling piece between the fixed element 75 and the surface 76 of the post 5. The fixed element 75 is arranged within the post retaining portion 67. The fixed element 75 comprises a guide surface 84, which is inclined relative to the surface 76 of the post, and relative to the bottom wall 80. The movable element 74 is vertically adjusted by means of a tightening screw 82, which is arranged in a fixed nut element 83, and which is loosely connected with the movable element 74. The nut element is arranged at an outside of the post retaining portion 67, and the movable element 74, constituted by a bent plate, extends into the retaining portion 67 from an upper end thereof, and abuts against the guide surface 84 of the fixed element 75. When tightening the tightening screw 82, the movable element 74 is forced downwards between the guide surface 84 and the surface 76 of the post 5 like a wedge. Thereby the post 5, and more particularly the flanges 86 thereof, is pushed against the edges of the side walls 81 of the post retaining portion 67.

[0032] This kind of post shape and connection of the post holder 7 and the post 5 is advantageous in that the opposite side of the post, having a similar groove shape, is free to use in the full length of the post for connecting other parts.

[0033] While the invention has been illustrated and described in detail in the drawings and foregoing description, such illustration and description are to be considered illustrative or exemplary and not restrictive; the invention is not limited to the disclosed embodiments.

[0034] Other variations to the disclosed embodiments can be understood and effected by those skilled in the art in practicing the claimed invention, from a study of the drawings, the disclosure, and the appended claims. In the claims, the word "comprising" does not exclude other elements or steps, and the indefinite article "a" or "an" does not exclude a plurality. The mere fact that certain measures are recited in mutually different dependent claims does not indicate that a combination of these measures cannot be used to advantage. Any reference signs in the claims should not be construed as limiting the scope.

## REFERENCES CITED IN THE DESCRIPTION

This list of references cited by the applicant is for the reader's convenience only. It does not form part of the European patent document. Even though great care has been taken in compiling the references, errors or omissions cannot be excluded and the EPO disclaims all liability in this regard.

### Patent documents cited in the description

- [GB2336391A](#) [0004]

## P A T E N T K R A V

1. Monteringsindretning til et midlertidigt kantafskærmningssystem, som omfatter stolper (5) og kantafskærmningskomponenter (2-4, 9), der kan monteres ved stolperne, hvor indretningen omfatter:

5 en panelholder (6, 110) omfattende et langstrakt stolpeglidestykke (40, 111), som kan anbringes bevægeligt ved en stolpe for at udstrække sig parallelt med stolpen, og to panelstøtter (47, 48, 115, 116), fastgjort til stolpeglidestykket i en afstand fra hinanden, hvor hver panelstøtte omfatter

10 en langstrakt støttedel (91, 92, 117, 118), som udstrækker sig vandret, på hvilken kantafskærmningskomponenterne (2-4, 9) skal hvile, definerende en langsgående retning, og et justerbart fastspændingselement (49, 50, 129, 130), som omfatter en lodret tungedel (93, 94, 129, 130) anbragt til at fastspænde kantafskærmningskomponenterne mod en fastspændingsoverflade (53, 54, 119, 120) af stolpeglidestykket, hvor monteringsindretningen er k e n d e t e g n e t ved, at hver panelstøtte  
15 yderligere omfatter:

et justeringselement (51, 52, 123, 124), som er anbragt til at justere afstanden mellem den lodrette tungedel og stolpeglidestykket i den langsgående retning af støttedelen, hvorved fastspænding af kantafskærmningskomponenterne mod fastspændingsoverfladen af stolpeglidestykket tilvejebringes.

20 2. Monteringsindretning ifølge krav 1, hvor justeringselementet er en skrue, som er rotationsmæssigt forbundet til støttedelen.

3. Monteringsindretning ifølge krav 1 eller 2, hvor justeringselementet er en skrue, som er fastgjort i langsgående retning i forhold til støttedelen.

25 4. Monteringsindretning ifølge et hvilket som helst af de foregående krav, hvor stolpeglidestykket (40, 111) omfatter en langstrakt føringsdel (41, 112), og øvre og nedre stolpeindgrebsdele (43, 44, 121, 122), der er anbragt henholdsvis ved top- og bundendedele (45, 46) af føringsdelen (41, 112).

30 5. Monteringsindretning ifølge et hvilket som helst af de foregående krav, hvor tungedelen (93, 94) er vedhæftet til støttedelen, og hvor støttedelen kan forbindes forskydelig i længderetningen med stolpeindgrebsdelene (43, 44).

6. Monteringsindretning ifølge krav 5, hvor støttedelen (91, 92) er formet som en kanal, der har sin åbning vendt sideværts mod en væg (58, 62) af stolpeindgrebsdelen (43, 44), hvor stolpeindgrebsdelen omfatter en justeringselementholder (95, 96), som er fastgjort til væggen og modtaget i støttedelen, hvor justeringselementet (51, 52) er i indgreb med justeringselementholderen således, at justeringselementet forskyder støttedelen i forhold til justeringselementholderen, når denne betjenes.

7. Monteringsindretning ifølge krav 6, hvor justeringselementet (51, 52) er en skrue, og justeringselementholderen (95, 96) er en manchete, som ved hjælp af gevind griber ind i skruen.

8. Monteringsindretning ifølge et hvilket som af de foregående krav, hvor støttedelen omfatter et langstrakt generelt U-formet beslag (117, 118), som er fastgjort til stolpeglidestykket (111) ved den åbne ende af beslaget, hvor beslaget rager frem fra stolpeglidestykket, og benene af beslaget i det væsentlige er længere end dets bredde.

9. Monteringsindretning ifølge krav 8, hvor justeringselementet (123, 124) er en skrue, som udstrækker sig inden i beslaget (117, 118), hvor skruen kan rotere, og har en fast langsgående position, hvor fastspændingselementet (129, 130) er i indgreb med gevind af skruen, og er forhindret i at rotere af benene af beslaget, og derved bevæges langs skruen, når skruen roteres.

10. Monteringsindretning ifølge et hvilket som helst af de foregående krav, hvilken omfatter en stolpeholder (7), som er anbragt til at blive tilvejebragt på en basis (8), hvor stolpeholderen omfatter et stolpestrammende aggregat (70).

11. Monteringsindretning ifølge krav 10, hvor det stolpestrammende aggregat (70) omfatter et bevægeligt element (74) og et fast element (75), hvor det bevægelige element er anbragt til at udøve en strammende kraft på en overflade (76) af stolpen (5), når det bevæges til en strammende position, hvor det bevægelige element udgør et udfyldningsstykke mellem det faste element og overfladen, og hvor mindst ét af det bevægelige element og det faste element omfatter en føringsoverflade (84), som har en hældning i forhold til overfladen af stolpen.

12. Monteringsindretning ifølge krav 11, hvor stolpeholderen (7) omfatter en langstrakt lodret stolpefastholdelsesdel (67), og en basisunderstøttende del (68) ragende vandret frem fra stolpefastholdelsesdelen, hvor stolpefastholdelsesdelen er kanalformet, og har en bundvæg (80), og modstående sidevægge (81), som rejser sig fra bundvæggen, hvor sidevæggene har et J-formet tværsnit.

13. Monteringsindretning ifølge et hvilket som helst af kravene 4 til 6, hvor føringsdelen (41, 112) er pladeformet og anbragt til at blive modtaget i en udsparring (85) af stolpen (5).

14. Midlertidigt kantafskærmningssystem, som omfatter monteringsindretningen ifølge et hvilket som helst af de foregående krav, og yderligere omfatter kantafskærmningselementer (2-4, 9), og stolper (5).

DRAWINGS

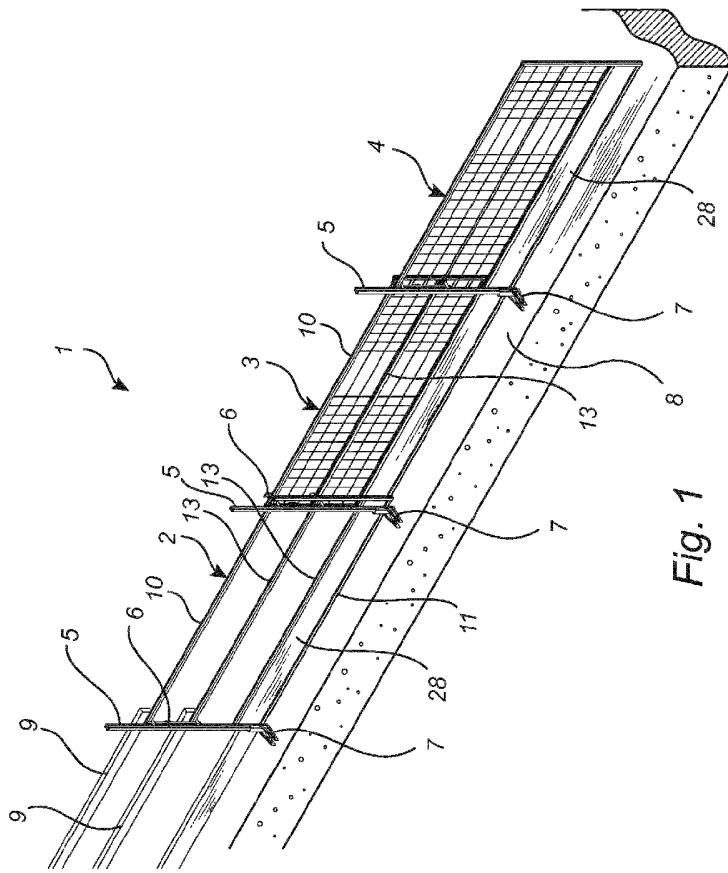

Fig. 1

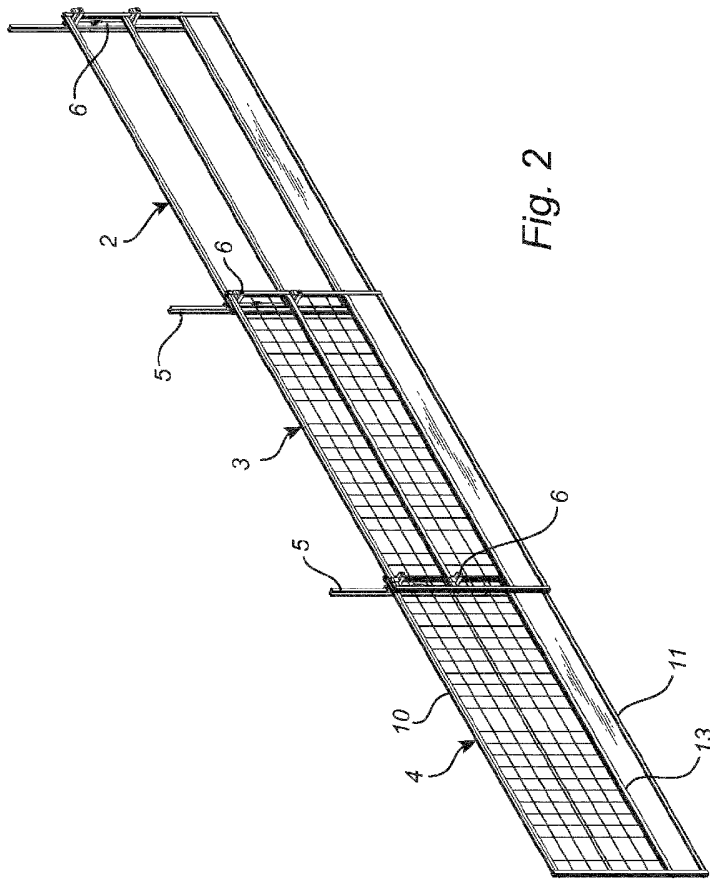

Fig. 2

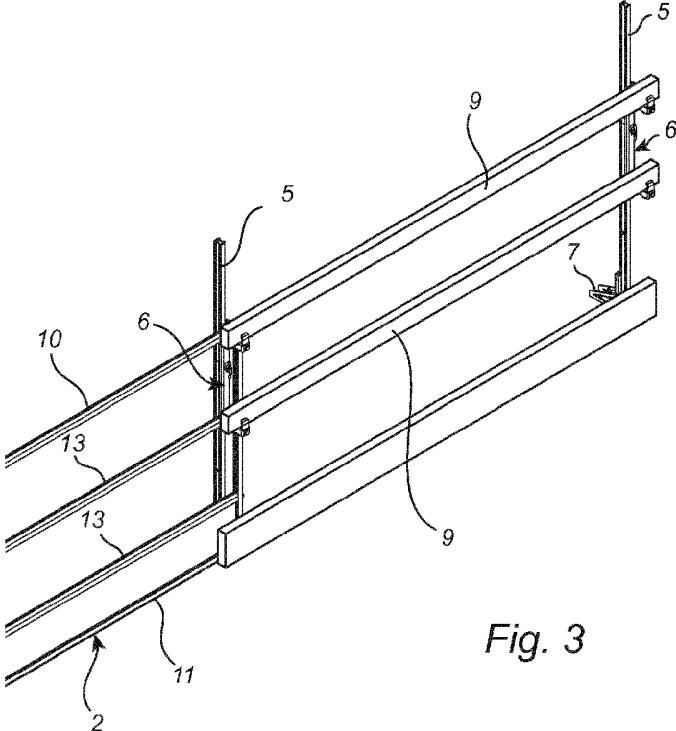

Fig. 3

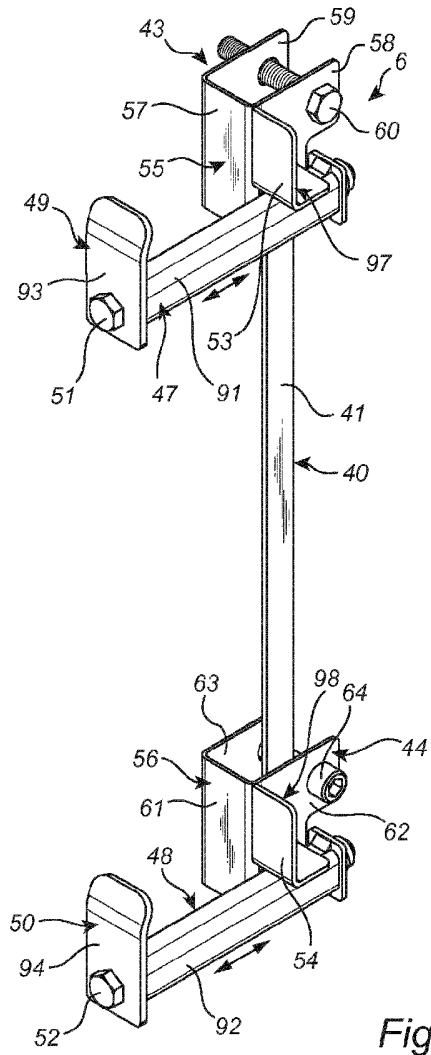

Fig. 4

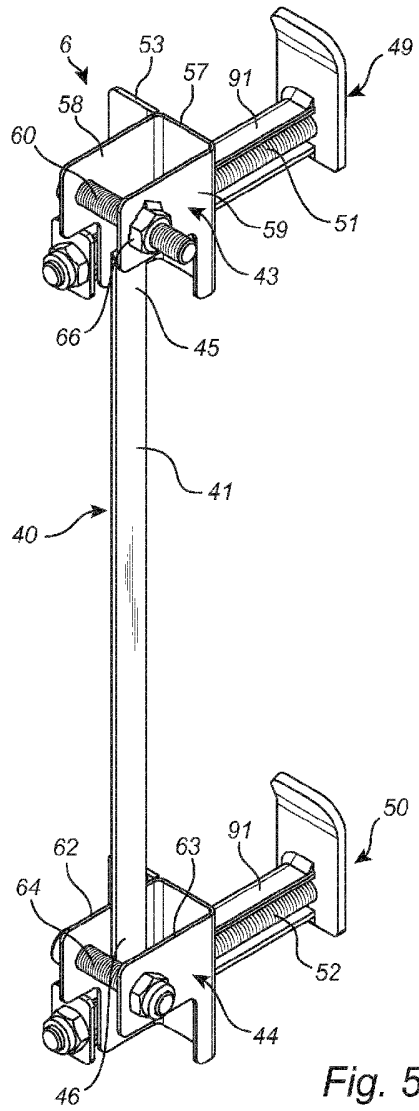

Fig. 5

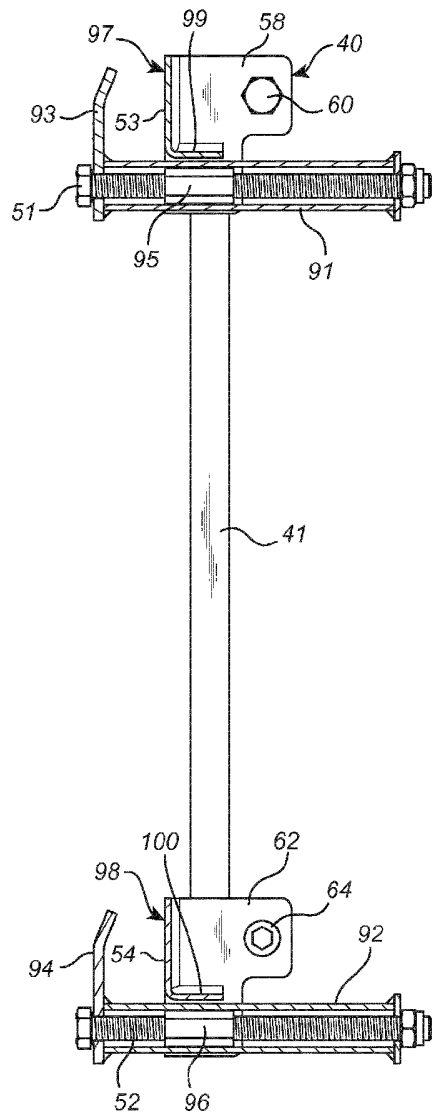

Fig. 6

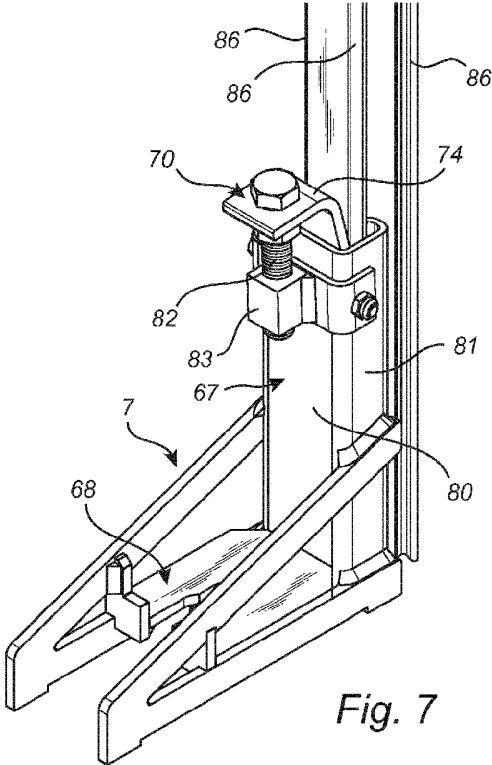

Fig. 7

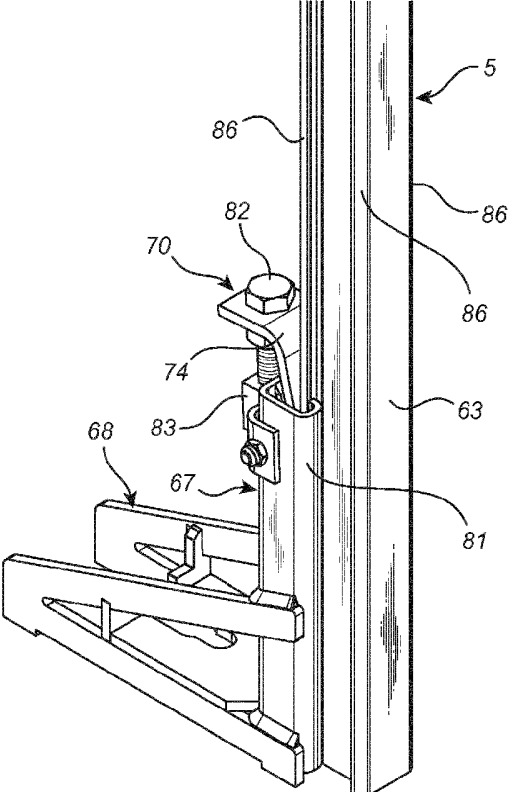
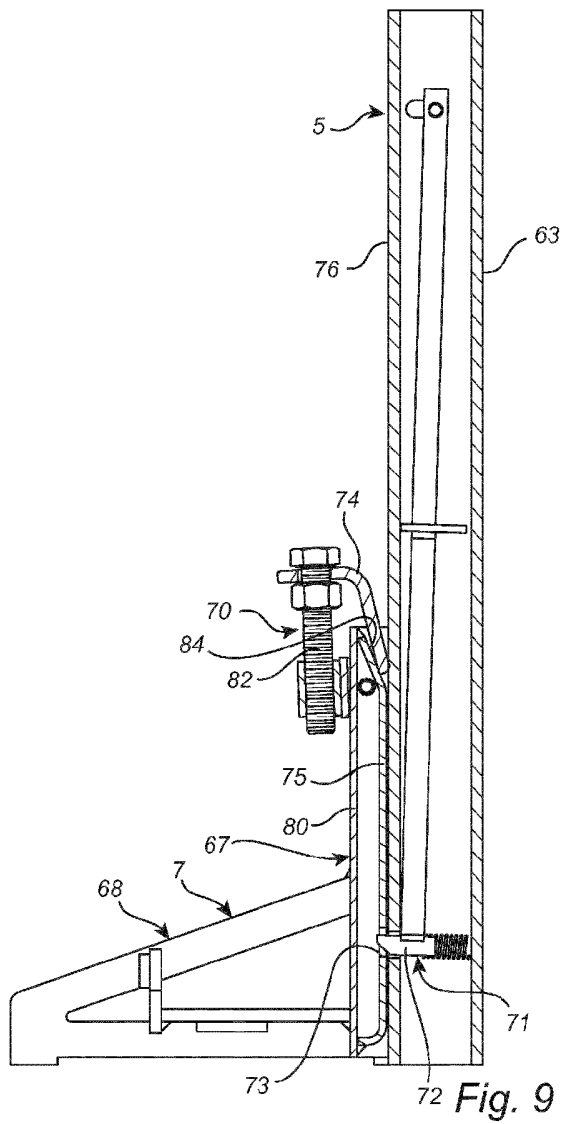

Fig. 8



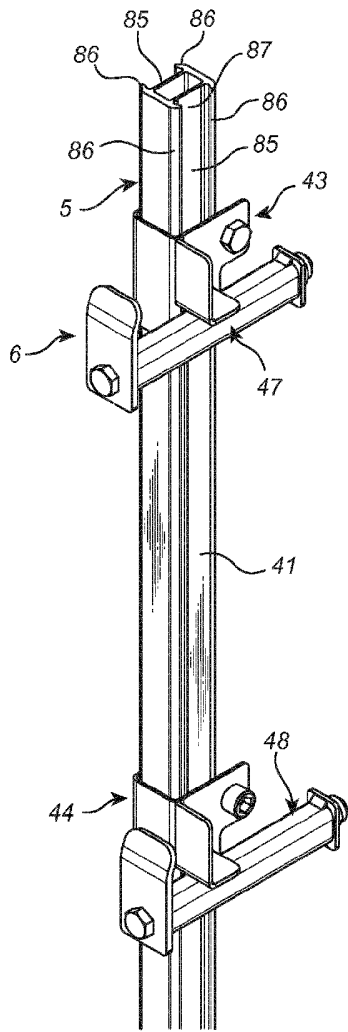

Fig. 10

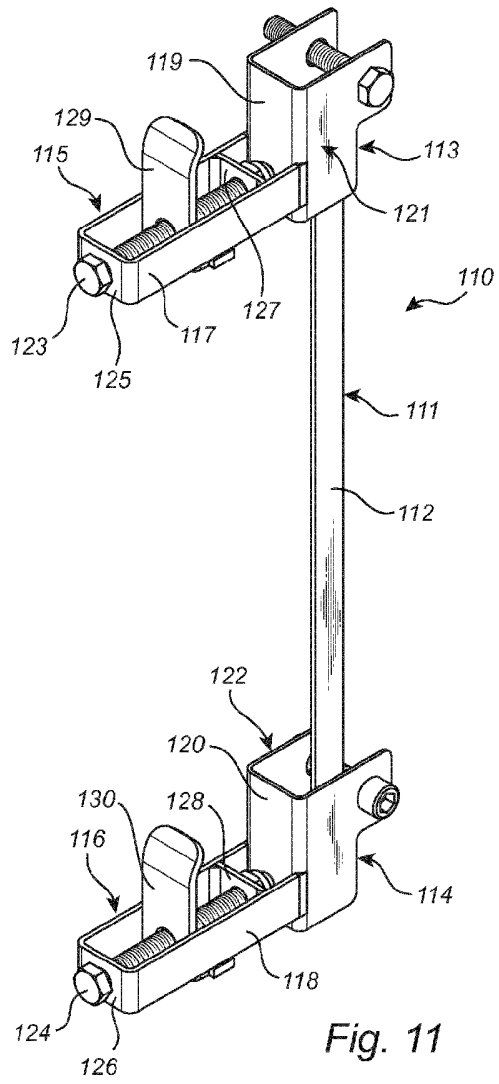

Fig. 11