

(19) World Intellectual Property Organization
International Bureau



(43) International Publication Date
16 November 2006 (16.11.2006)

PCT

(10) International Publication Number
WO 2006/119762 A1

- (51) International Patent Classification:
A61B 17/12 (2006.01)
- (21) International Application Number:
PCT/DK2005/000312
- (22) International Filing Date: 9 May 2005 (09.05.2005)
- (25) Filing Language: English
- (26) Publication Language: English
- (71) Applicant (for all designated States except US): **SCANDIMED INTERNATIONAL A.S.** [DK/DK]; Slotsherrensvej 409, DK-2600 Glostrup (DK).
- (72) Inventor; and
- (75) Inventor/Applicant (for US only): **CHAMI, Salah** [DK/DK]; Lindebakken 26, DK-3460 Birkerød (DK).
- (74) Agent: **A & A NYVANG**; V/Jens Nyvang Christensen, Langebjergvej 322 C, DK-3050 Humlebæk (DK).
- (81) Designated States (unless otherwise indicated, for every kind of national protection available): AE, AG, AL, AM,

AT, AU, AZ, BA, BB, BG, BR, BW, BY, BZ, CA, CH, CN, CO, CR, CU, CZ, DE, DK, DM, DZ, EC, EE, EG, ES, FI, GB, GD, GE, GH, GM, HR, HU, ID, IL, IN, IS, JP, KE, KG, KM, KP, KR, KZ, LC, LK, LR, LS, LT, LU, LV, MA, MD, MG, MK, MN, MW, MX, MZ, NA, NG, NI, NO, NZ, OM, PG, PH, PL, PT, RO, RU, SC, SD, SE, SG, SK, SL, SM, SY, TJ, TM, TN, TR, TT, TZ, UA, UG, US, UZ, VC, VN, YU, ZA, ZM, ZW.

(84) Designated States (unless otherwise indicated, for every kind of regional protection available): ARIPO (BW, GH, GM, KE, LS, MW, MZ, NA, SD, SL, SZ, TZ, UG, ZM, ZW), Eurasian (AM, AZ, BY, KG, KZ, MD, RU, TJ, TM), European (AT, BE, BG, CH, CY, CZ, DE, DK, EE, ES, FI, FR, GB, GR, HU, IE, IS, IT, LT, LU, MC, NL, PL, PT, RO, SE, SI, SK, TR), OAPI (BF, BJ, CF, CG, CI, CM, GA, GN, GQ, GW, ML, MR, NE, SN, TD, TG).

Published:
— with international search report

For two-letter codes and other abbreviations, refer to the "Guidance Notes on Codes and Abbreviations" appearing at the beginning of each regular issue of the PCT Gazette.

(54) Title: LIGATOR

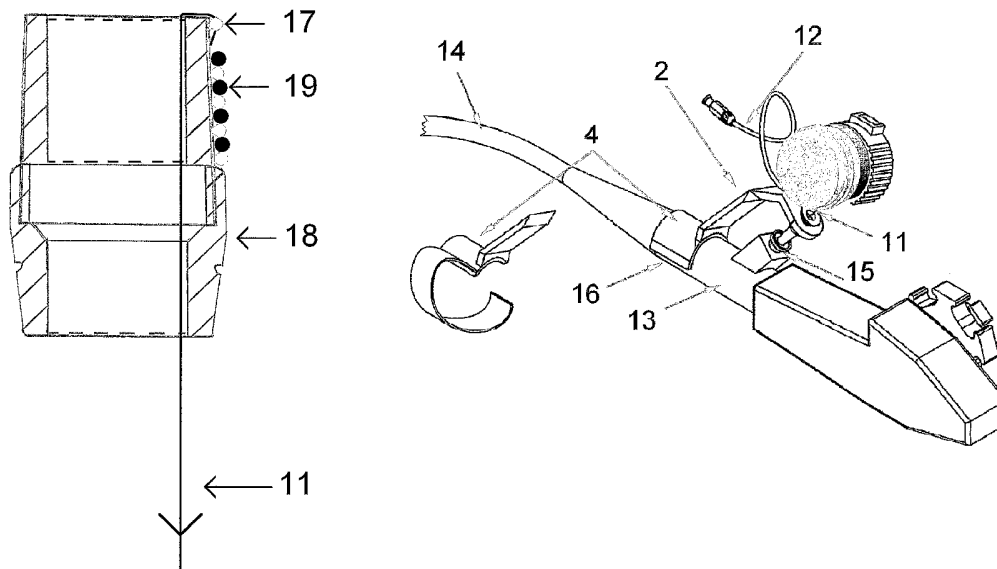

(57) Abstract: An apparatus applicable for the ligation of internal tissue in a created or natural cavity in animals or in the human body for varicose veins in the gullet or a duodenal diverticulum by means of an elastic band (19) while observing the ligation through an endoscope comprises: an automatic trigger unit (1) mounted firmly on the handle of the endoscope which subsequently can release a number of elastic bands (19) with the aid of a single stranded trigger cord (11). Hereby is achieved that only a single elastic band (19) is released for each ligation and the establishment of an one-man-operated equipment.

WO 2006/119762 A1

LIGATOR

5 This invention relates to medical ligating instruments, and more particularly to devices used to ligate body tissue in a created or natural cavity in animals or in the human body fx varicose veins in the gullet or a duodenal diverticulum by means of individual elastic bands while observing the legations through an endoscope.

10 It takes supreme effort to manoeuvre an endoscope while you ligate internal tissue in a created or natural cavity in animals or in the human body fx varices veins in the gullet or a duodenal diverticulum by means of individual elastic band while observing the legations through an endoscope if the surgeon is supposed to manoeuvre the endoscope and activate the release of a number of elastic band all by him self. Therefore it is common practice an assistant helps the surgeon while he manoeuvre the endoscope and releases elastic bands during the
15 actual ligation.

20 Furthermore it is very inconvenient for the patient when the endoscope is lead in to the gullet or other openings of the human body, therefore it most advantageous to perform a save and quick operation.

25 For known ligating instruments related to the present invention the trigger unit is not firmly fixed at the distal end the endoscope se fx US 6.149.659. Therefore you must hold the trigger unit firmly with one hand, by the other hand you can draw the trigger cord to obtain the ligation of the desired varix or diverticulum. A third and eventually a forth hand are needed to hold and manoeuvre the endoscope.

30 For known ligating instruments related to the present invention 2 or more trigger cords are used in releasing the rubber bands see fx US 6.235.040 and WO 9716120. The consequence of having 2 or more trigger cord is that the cords can cross one and another and squeeze fx a varix which easily can result in a bleeding and put the patient health at stake and make the treatment very troublesome.

Therefore it is an object of the present invention to provide an improved ligating instrument where the surgeon very fast and with great safety can perform the operation by himself using a automatic trigger unit according to the invention which further if necessary can lead to saving of staff in connection with the surgery.

Further it is an object of the present invention to provide an improved ligating instrument where the great risk of squeezing body tissue fx a varix in the gullet is eliminated in connection with the ligation.

The first mentioned object according to the present invention you can achieve using a ligating instrument, which include the means characterized in claim 1, whereby the trigger unit is mounted firmly on the endoscope. Hereby is produced a one-man-operated endoscope, where the surgeon has complete control over the endoscope.

The grip of the trigger unit on the endoscope at the joint between the tube and the handle of the endoscope can be secured by means of a U-formed bracket on the connecting joint.

To enable the grip of the trigger unit on the endoscope at the joint between the tube and the handle of the endoscope no matter the diameter of the endoscope the connecting joint can be provided with a fixture fx a velcro tape.

When the U-formed bracket, as specified in claim 4, is connected with the trigger unit by means of one or more toggle joint(s), you can comfortable to begin with secure the socket-shaped nozzle at the proximale end of the accessory channel of the endoscope and afterwards turn the U-formed bracket for the fasten at the cylindrical joint between the tube and the handle of the endoscope.

It has surprisingly been revealed that it is possible to overcome the drawbacks which occur when trigger cords cross one another which can lead to squeezing of internal tissue such as a varix that consequently can lead to severe bleeding, when you according to claim 5 have a single stranded trigger cord at the distale end of the trigger cord.

The use of a single stranded trigger cord implies an adequate big size of the knots or beads because a single knot or bead on the distale end of the trigger cord is responsible for that an elastic band is guided over the distale end of the bush and released for the ligation of a specific internal tissue.

When the trigger cord as indicated in clam 6 is manufactured of a metal wire, preferably a twisted metal wire, you achieve at least two essential advantages because a twisted metal wire simultaneous is rigid and very flexible, therefore the surgeon has an optimal touch with the firing of elastic bands and because of the big strength of metal wires very tiny dimension can be used which leave the optimally space in the accessory channel for the flushing if a bleeding occurs during the ligation.

The use of the one-man-operated, automatic, dual fixed, trigger unit according to the invention provides an adapted up winding of the trigger cord, corresponding to the release of a single elastic band at the distale end of the endoscope, said up winding, as indicated in claim 7, you can obtain by turning the revolving parts simultaneously to the built-in stop at their extreme position, where under the release of an elastic band takes place and the simultaneously compressing of a built-in spring is performed. After the release of an elastic band has taken place the revolving part at which the proximale end of the trigger cord is fixed, leaves its engagement with part at which, there in an embodiment, has a winding track and automatically comes back to

its starting point while the trigger cord is coiled up at said winding track

5 When the trigger unit has a sound signal as indicated in claim 8, at the extreme position of the revolving parts, the surgeon instantly becomes aware of that the release of an elastic band has taken place, where after the surgeon instantly can let go of the revolving parts, where after the tensed revolving part automatically goes back to its starting point. Hereby is obtained the obvious advantage that the operation can be
10 performed in a shorter amount of time which means less discomfort by the endoscope for the patient.

15 For the flushing if a bleeding occurs during the ligation the trigger unit according to the invention has an integrated canal upon which a flexible injection tube can be mounted as indicated in claim 9, when the injection tube is mounted the surgeon can flush the fiber optic from any angle at the proximale end of the endoscope by the means of a syringe.

20 By manufacturing of a bush according to the invention, there is provided a retainer for the elastic bands by the use of a single stranded trigger cord. The use of a single stranded trigger cord leads to a more safe operation for the patient and more over said bush charged with
25 elastic band is considerably more easy and therefore less expensive to produce.

30 A bush charged with elastic band as indicated in claim 10 is prepared to be in mesh with the distale end of an endoscope after joining the trigger cord from the bush with the trigger cord from the trigger unit via the accessory channel of the endoscope.

Description of the drawing according to the invention where:

fig. 1 is a perspective view of a trigger unit,

5 fig.2 is a perspective view of a trigger unit where a trigger cord, is
guided into the trigger unit,

fig. 3 is a longitudinal section through a bush which upon is placed
flexible trigger cord with beads and elastic band and

10 fig. 4 is a perspective view of a trigger unit according to the present
invention firmly mounted on the proximale end of an endoscope.

15 Fig. 1 illustrates a trigger unit, which in general is named with the
reference number 1. It has a connecting part 2, on which a socket-
shaped nozzle 3 is mounted, further a U-formed bracket 4 is mounted
on the connecting part 2 by means of a toggle joint 5. One of the two
parts 6 and 7 can revolve together on a shaft, not shown, since the
shaft is lead through a bedding, not shown, in the connecting part 2.
20 The first part 6 has a winding track 8 which is ment for the guiding
and winding of the trigger cord 11. The other revolving part 7 has a
built-in spring, which after the release of an elastic band 19 ensure,
that the revolving part 7 leaves its engagement with part 6 and
automatically comes back to its starting point, while the part 6 ensure
an automatically winding of the trigger cord 11 on the winding track
25 8. From the socket-shaped nozzle 3 the trigger cord 11 is lead through
the hole 9 in the winding track 8 and through the trigger units part 6,
part 2 and part 7 and further to the cord clamp 10 where the cord is
secured. The cord clamp 10 is shown in its locked position on fig. 1.

30 Fig. 2 illustrates a trigger unit 1 seen from below, where the U-formed
bracket 4 is connected with the trigger unit 1 by means of one or more
toggle joint(s) 5.

Fig. 3 illustrates how the distale end of the trigger cord 11 is supplied with a number of beads 17. The trigger cord 11 is, as shown, guided through a bush 18 and folded backwards on the outer end of the bush. The bush is mounted on the distale end of the tube of the endoscope 14. Elastic band 19 is placed so they encircling the bush 18 and the trigger cord 11 in between the beads 17.

Therefore it is obvious, if the trigger cord 11 is pulled inwards into the tube of the endoscope 4, meaning downwards on fig. 3, the beads 17 on the distale end of the trigger cord 11 will guide the elastic bands 19 over the distale end of the bush 18 and successively release the elastic bands 19.

The pull of the trigger cord 11 into the tube of the endoscope 4 is achieved when the proximale end of the trigger cord 11 is fastened at the winding track 8 on the trigger unit 1 by means of the cord clamp 10. Hereby can the revolving parts revolve from the starting position to their extreme position where there is a built-in stop, during which the release of a elastic takes 19 place.

Fig. 4 illustrates a trigger unit mounted on the proksimale end of an endoscope. The trigger cord 11 is guided from the proksimale opening 15 of the endoscope to the trigger unit 1, on which a flexible injection tube 12 can be fixed. The dual fixed trigger unit 1 is partly fixed by the anchoring of the socket-shaped nozzle 3 on the trigger unit 1 into the accessory channel 15 of the endoscope and partly by the connecting unit 2 on the trigger unit 1 via a U-formed bracket 4.

When operating, the distale end of the endoscope which is supplied with a loaded bush 18 is guided over a varicose vein, while said vein is observe through the endoscope or on a monitor. If it is necessary the varicose vein can be sucked into the bush 18 using a pump.

5

When the varicose vein is in place, which can be observed through the endoscope or on a monitor an elastic band 19 can be released, said band then places itself around the varicose vein, which leads to halt of the blood circulation and consequently to necrosis of the tissue. While the distale end of the endoscope containing a loaded bush one or more varicose vein(s) can be treated in the same manner, as long as there is an elastic band on the bush 18. In this way individual elastic band 19 can be placed around their separate varicose vein.

CLAIMS

1. Apparatus used for the ligation of internal tissue in a created or natural cavity in animals or in the human body fx varicose veins in the gullet or a duodenal diverticulum by means of individual elastic band (19) while observing the legations through an endoscope c h a r a c t e r i z e d in that it comprises:

an automatic trigger unit (1) mounted firmly on the handle of the endoscope which subsequently can release a number of elastic bands (19) with the aid of a trigger cord (11) where the non-elastic part of the trigger cord (11) is guided through the endoscope where a single, flexible trigger cord (11) in the distale end is guided through the bush (18) and folded backwards on the outer end of said bush where it is provide with a number of knots or beads (17), where the trigger cord is guided round the bush (18) followed by an elastic band (19) encircling the bush (18) and

where a dual fixation of the trigger unit (1) partly is done by the anchoring of the socket-shaped nozzle (3) on the trigger unit (1) into the accessory channel (15) of the endoscope and partly by the connecting unit (4) on the trigger unit (1) where the connecting part (2) is prepared to mesh with the cylindrical joint (16) between the tube (14) and the handle (13) of the endoscope.

2. Connecting unit according to claim 1 c h a r a c t e r i z e d in that said unit is a U-formed bracket (4) on the trigger unit (1) prepared to mesh with the cylindrical joint (16) between the tube (14) and the handle (13) of the endoscope.

3. Connecting unit according to claim 1 c h a r a c t e r i z e d in that said unit is meshed by means of a fixture fx a velcro tape.

4. Connecting unit according to claim 2 c h a r a c t e r i z e d in that said unit is a U-formed bracket (4) has one or more toggle joint(s) (5).

5. One-man-operated, automatic, dual fixed, trigger unit according to claim 1 c h a r a c t e r i z e d in that the distale end of the trigger cord is single stranded.

6. Non-elastic trigger cord according to claim 1 c h a r a c t e r i z e d in that said cord is manufactured of a metal wire, preferably as a twisted metal wire.

7. One-man-operated, automatic, dual fixed, trigger unit according to claim 1 c h a r a c t e r i z e d in that the revolving parts (6, 7) has a built-in spring and a built-in stop at their extreme position.

8. One-man-operated, automatic, dual fixed, trigger unit according to claim 1 c h a r a c t e r i z e d in that the revolving parts (6, 7) at their extreme position produce a sound signal fx a click.

9. One-man-operated, automatic, dual fixed, trigger unit according to claim 1 c h a r a c t e r i z e d in that the trigger unit (1) has an integrated canal upon which a flexible injection tube (12) can be mounted.

10. Bush used for disengagement of elastic bands, when a pull of the trigger cord is evoked by a trigger unit c h a r a c t e r i z e d in that the bush has one and only one trigger cord (11) supplied with a number of knots or beads (17), where the trigger cord is guided round the bush (18) followed by a elastic band (19) encircling the bush (18).

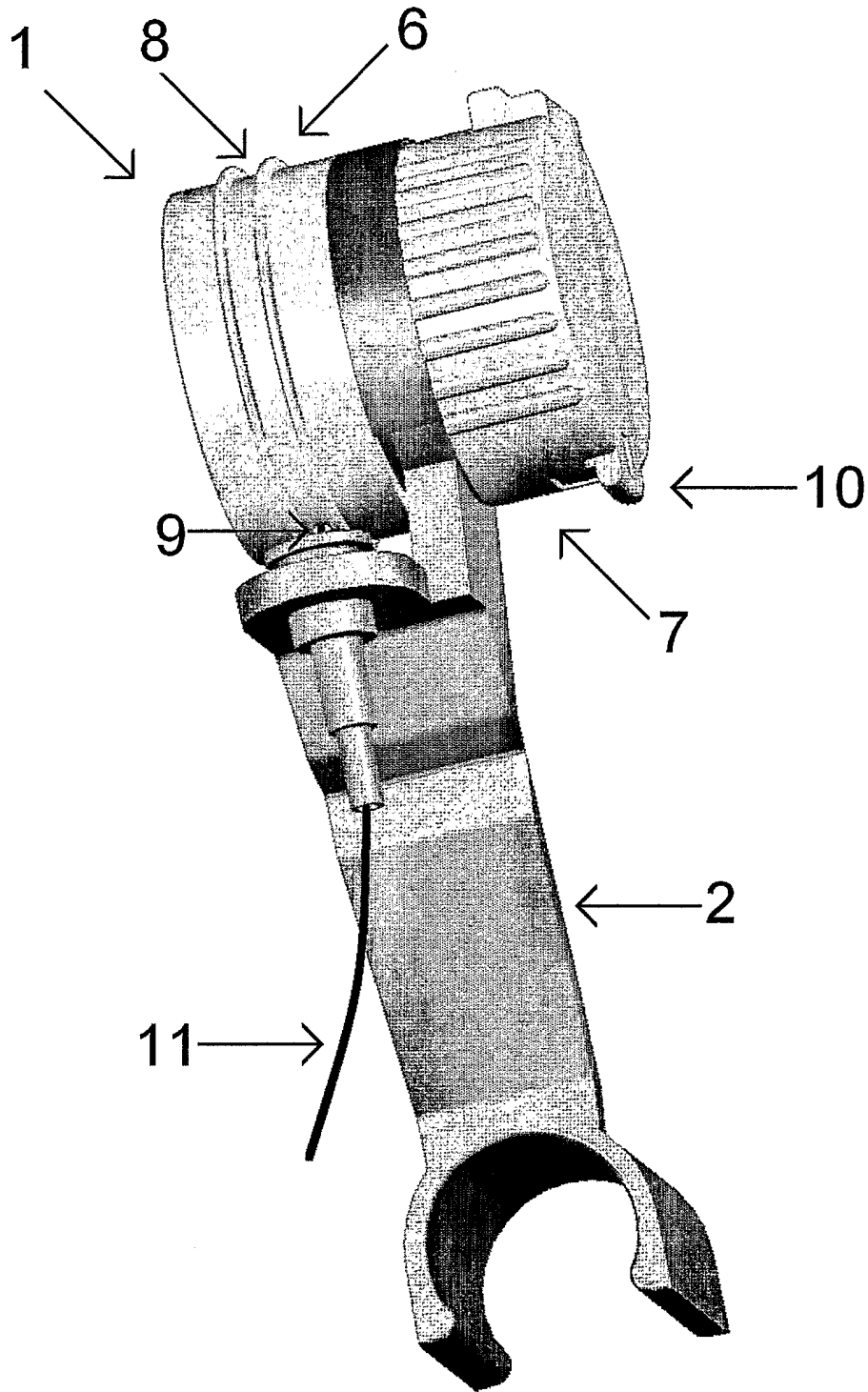

Fig. 1

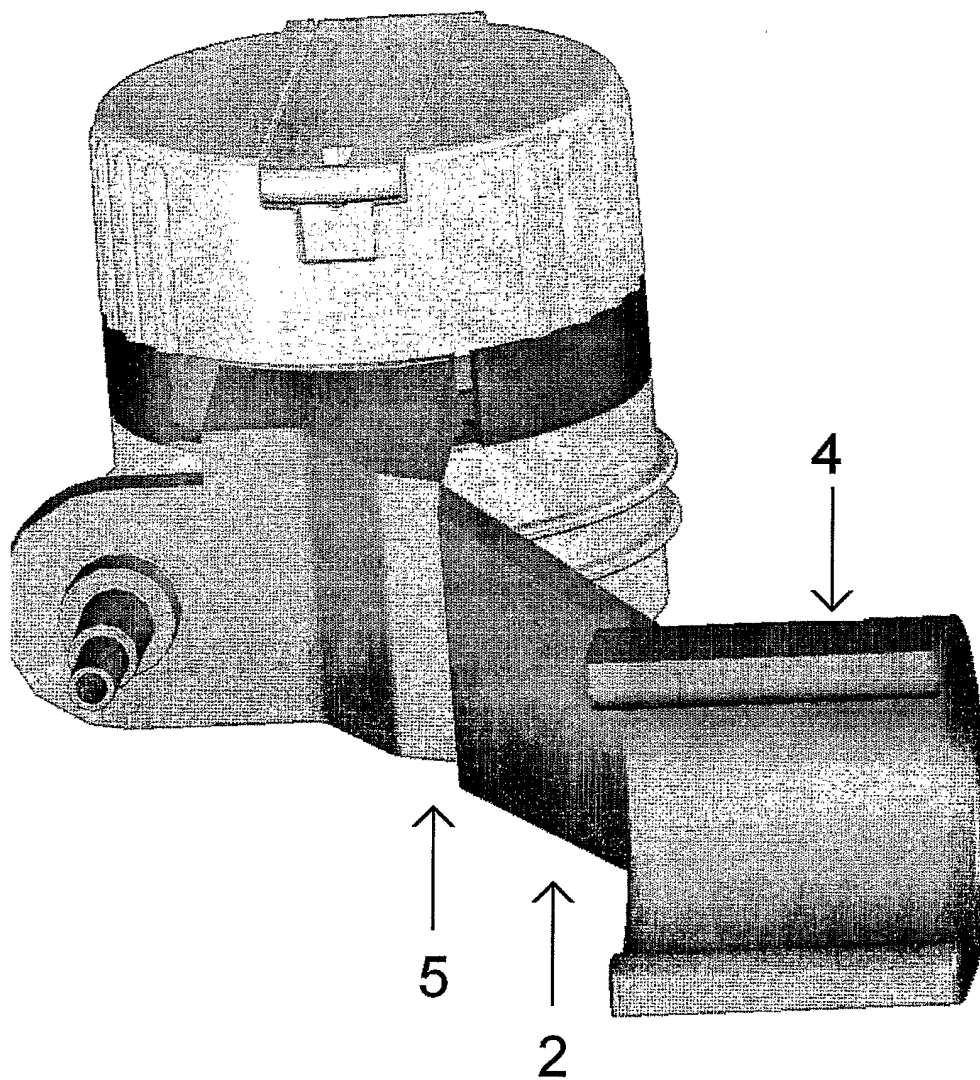

Fig. 2

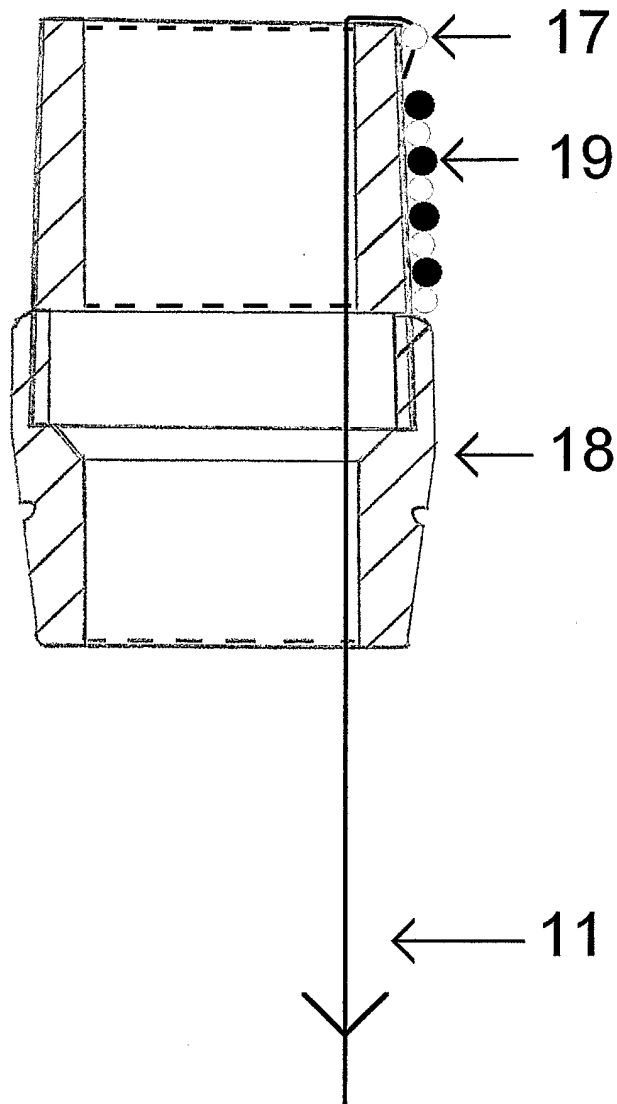

Fig. 3

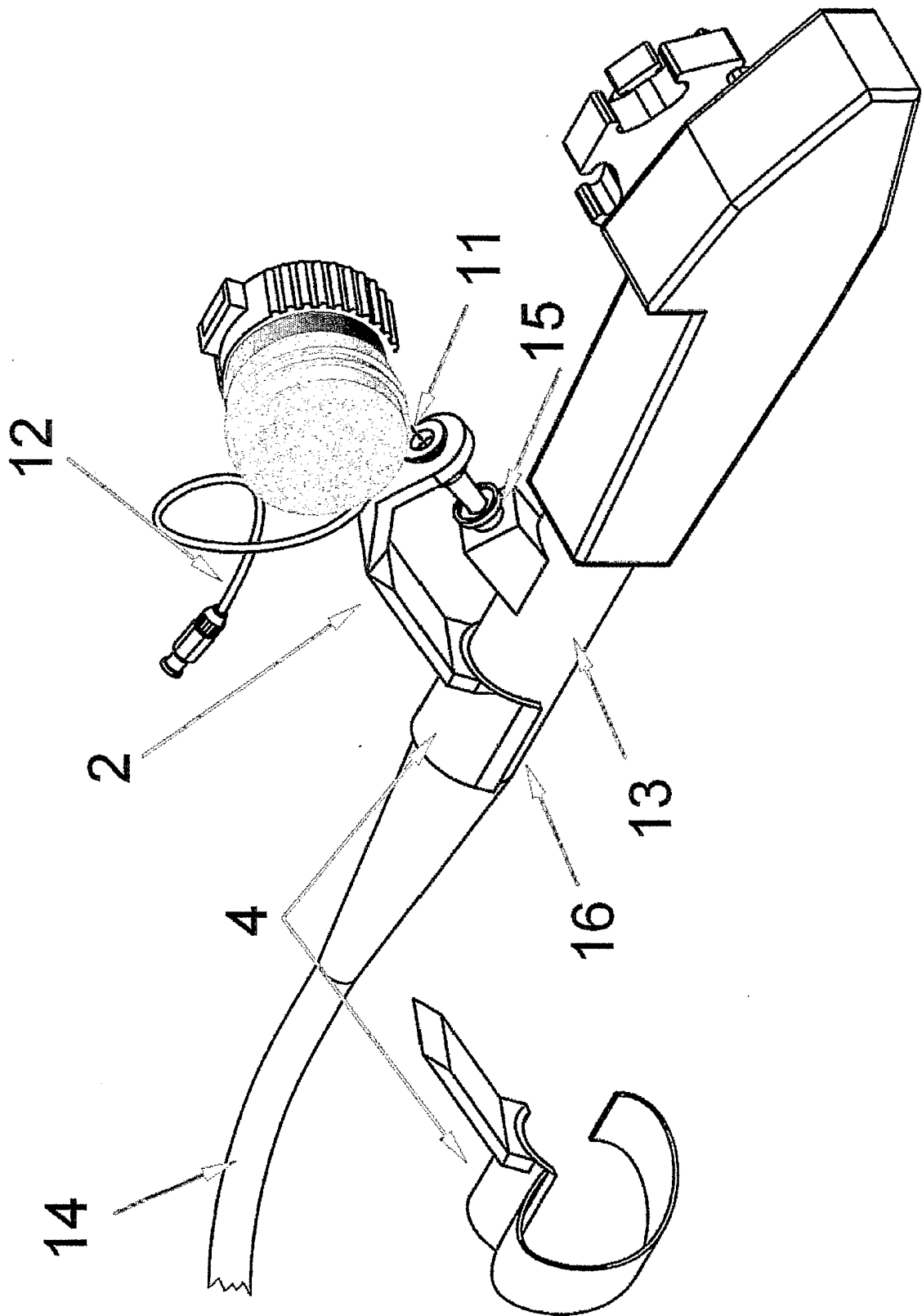

Fig. 4

INTERNATIONAL SEARCH REPORT

International application No.

PCT/DK 2005/000312

A. CLASSIFICATION OF SUBJECT MATTER

IPC: see extra sheet

According to International Patent Classification (IPC) or to both national classification and IPC

B. FIELDS SEARCHED

Minimum documentation searched (classification system followed by classification symbols)

IPC: A61B

Documentation searched other than minimum documentation to the extent that such documents are included in the fields searched

SE,DK,FI,NO classes as above

Electronic data base consulted during the international search (name of data base and, where practicable, search terms used)

EPO-INTERNAL, WPI DATA, PAJ

C. DOCUMENTS CONSIDERED TO BE RELEVANT

Category*	Citation of document, with indication, where appropriate, of the relevant passages	Relevant to claim No.
A	US 5320630 A (M. AHMED), 14 June 1994 (14.06.1994), figures 14,15, abstract --	1-10
A	WO 0245595 A2 (WILSON-OOK MEDICAL INC.), 13 June 2002 (13.06.2002), figure, abstract --	1-10
A	US 5398844 A (E. ZASLAVSKY ET AL), 21 March 1995 (21.03.1995), figure, abstract --	1-10
A	US 6051003 A (M.S.H. CHU ET AL), 18 April 2000 (18.04.2000), figure, abstract --	1-10

 Further documents are listed in the continuation of Box C. See patent family annex.

* Special categories of cited documents:

"A" document defining the general state of the art which is not considered to be of particular relevance

"E" earlier application or patent but published on or after the international filing date

"L" document which may throw doubts on priority claim(s) or which is cited to establish the publication date of another citation or other special reason (as specified)

"O" document referring to an oral disclosure, use, exhibition or other means

"P" document published prior to the international filing date but later than the priority date claimed

"T" later document published after the international filing date or priority date and not in conflict with the application but cited to understand the principle or theory underlying the invention

"X" document of particular relevance: the claimed invention cannot be considered novel or cannot be considered to involve an inventive step when the document is taken alone

"Y" document of particular relevance: the claimed invention cannot be considered to involve an inventive step when the document is combined with one or more other such documents, such combination being obvious to a person skilled in the art

"&" document member of the same patent family

Date of the actual completion of the international search

22 December 2005

Date of mailing of the international search report

23 -12- 2005

Name and mailing address of the ISA/
Swedish Patent Office
Box 5055, S-102 42 STOCKHOLM
Facsimile No. +46 8 666 02 86

Authorized officer

Hélène Sundström / MRo
Telephone No. +46 8 782 25 00

INTERNATIONAL SEARCH REPORT

International application No.
PCT/DK 2005/000312

C (Continuation). DOCUMENTS CONSIDERED TO BE RELEVANT

Category*	Citation of document, with indication, where appropriate, of the relevant passages	Relevant to claim No.
A	US 6059798 A (M.J. TOLKOFF), 9 May 2000 (09.05.2000), figure, abstract -----	1-10

INTERNATIONAL SEARCH REPORT

International application No.
PCT/DK2005/000312

INTERNATIONAL PATENT CLASSIFICATION (IPC):

A61B 17/12 (2006.01)

INTERNATIONAL SEARCH REPORT

International application No.
PCT/DK2005/000312

Box No. II Observations where certain claims were found unsearchable (Continuation of item 2 of first sheet)

This international search report has not been established in respect of certain claims under Article 17(2)(a) for the following reasons:

1. Claims Nos.:
because they relate to subject matter not required to be searched by this Authority, namely:

2. Claims Nos.: 10 in part
because they relate to parts of the international application that do not comply with the prescribed requirements to such an extent that no meaningful international search can be carried out, specifically:

Claim 10 is not supported by the description as required by Article 6 PCT, as its scope is broader than justified by the

3. Claims Nos.:
because they are dependent claims and are not drafted in accordance with the second and third sentences of Rule 6.4(a).

Box No. III Observations where unity of invention is lacking (Continuation of item 3 of first sheet)

This International Searching Authority found multiple inventions in this international application, as follows:

1. As all required additional search fees were timely paid by the applicant, this international search report covers all searchable claims.
2. As all searchable claims could be searched without effort justifying an additional fee, this Authority did not invite payment of any additional fee.
3. As only some of the required additional search fees were timely paid by the applicant, this international search report covers only those claims for which fees were paid, specifically claims Nos.:

4. No required additional search fees were timely paid by the applicant. Consequently, this international search report is restricted to the invention first mentioned in the claims; it is covered by claims Nos.:

Remark on Protest

- The additional search fees were accompanied by the applicant's protest and, where applicable, the payment of a protest fee.
- The additional search fees were accompanied by the applicant's protest but the applicable protest fee was not paid within the time limit specified in the invitation.
- No protest accompanied the payment of additional search fees.

INTERNATIONAL SEARCH REPORT

International application No.
PCT/DK2005/000312

Box II.2

description and drawings. The reasons therefore are the following:

Claim 10 relates to a bush for disengagement of elastic bands. The claim cover all products having this characteristic, whereas the description provides support for only a very limited number of such products, namely medical endoscopic instrument used to ligate internal body tissue.

Consequently, a search has been carried out for those parts of claim 10 which it supported and disclosed, that is an apparatus used for ligation of internal tissue comprising a bush for disengagement of elastic bands.

INTERNATIONAL SEARCH REPORT

Information on patent family members

International application No.

PCT/DK 2005/000312

US	5320630	A	14/06/1994	US	5423834	A	13/06/1995
				US	5462559	A	31/10/1995
				US	5624453	A	29/04/1997
				US	6007551	A	28/12/1999
				US	6149659	A	21/11/2000
				US	6730101	B	04/05/2004

WO	0245595	A2	13/06/2002	AU	2893002	A	18/06/2002
				CA	2430731	A	13/06/2002
				EP	1339330	A	03/09/2003
				JP	2004514530	T	20/05/2004
				US	20020072757	A	13/06/2002

US	5398844	A	21/03/1995	AT	227105	T	15/11/2002
				CA	2181465	A	03/08/1995
				DE	69528752	D,T	10/07/2003
				EP	0742748	A,B	20/11/1996
				JP	3510893	B	29/03/2004
				JP	9508299	T	26/08/1997
				US	RE36629	E	28/03/2000
				WO	9520464	A	03/08/1995

US	6051003	A	18/04/2000	US	5697940	A	16/12/1997
				CA	2146664	A,C	28/04/1994
				DE	69331394	D,T	14/08/2002
				DK	696900	T	11/03/2002
				EP	0696900	A,B	21/02/1996
				EP	1145684	A	17/10/2001
				ES	2168097	T	01/06/2002
				JP	3457314	B	14/10/2003
				JP	8502198	T	12/03/1996
				US	5269789	A	14/12/1993
				US	5356416	A	18/10/1994
				WO	9408517	A	28/04/1994

US	6059798	A	09/05/2000	US	6610070	B	26/08/2003
				US	20030187464	A	02/10/2003
				AU	737304	B	16/08/2001
				AU	7795998	A	21/12/1998
				CA	2291703	A	10/12/1998
				DE	69830402	D	00/00/0000
				EP	0986332	A,B	22/03/2000
				JP	2002502291	T	22/01/2002
				US	5853416	A	29/12/1998
				WO	9855030	A	10/12/1998