

(19) **DANMARK**

(10) **DK/EP 3208404 T3**



(12) **Oversættelse af
europæisk patentskrift**

Patent- og
Varemærkestyrelsen

-
- (51) Int.Cl.: ***E 04 H 12/08 (2006.01)*** ***E 04 H 12/24 (2006.01)*** ***E 04 H 12/34 (2006.01)***
F 03 D 13/10 (2016.01) ***F 03 D 13/20 (2016.01)***
- (45) Oversættelsen bekendtgjort den: **2020-03-09**
- (80) Dato for Den Europæiske Patentmyndigheds bekendtgørelse om meddelelse af patentet: **2019-11-27**
- (86) Europæisk ansøgning nr.: **17156622.7**
- (86) Europæisk indleveringsdag: **2017-02-17**
- (87) Den europæiske ansøgnings publiceringsdag: **2017-08-23**
- (30) Prioritet: **2016-02-19 DE 102016002372**
- (84) Designerede stater: **AL AT BE BG CH CY CZ DE DK EE ES FI FR GB GR HR HU IE IS IT LI LT LU LV MC MK MT NL NO PL PT RO RS SE SI SK SM TR**
- (73) Patenthaver: **Senvion GmbH, Überseering 10, 22297 Hamburg, Tyskland**
SIAG Industrie GmbH, Kamenzer Strasse 3, 04347 Leipzig, Tyskland
- (72) Opfinder: **EDELMANN, Ulf, Lütt Ecken 14a, 24787 Fockbek, Tyskland**
Petersen, Jens, Wichelweg 24d, 24811 Brekendorf, Tyskland
- (74) Fuldmægtig i Danmark: **Plougmann Vingtoft A/S, Strandvejen 70, 2900 Hellerup, Danmark**
- (54) Benævnelse: **FREMGANGSMÅDE OG INDRETNING TIL MONTERING AF ET RØRTÅRNSEGMENT**
- (56) Fremdragne publikationer:
US-A1- 2015 176 299

METHOD AND APPARATUS FOR MOUNTING A PIPE TOWER SEGMENT

The invention relates to a method for mounting an annular tubular tower segment made from at least three ring segment-shaped panels, and to a mounting aid which is particularly suitable therefor.

Tubular tower structures composed of several tubular tower segments are known. Corresponding towers are in particular frequently used as towers for wind turbines, wherein the nacelle with the rotor of the wind turbine rotatably mounted therein is arranged on the tower head.

It is known to prefabricate tubular tower segments as tubular components in such a way that they only have to be placed on a foundation or a tubular tower segment which has already been erected and connected to this at the installation site. For the connection, the tubular tower segments can be welded together or screwed together on the flanges provided for this purpose.

The maximum diameter as tubular components of prefabricated tubular tower segments is limited by transportability requirements. For example, the diameter of corresponding tubular tower segments for road transport must be less than 4.5 m in order to be able to maintain the clearance height of bridges, for example. From a corresponding maximum diameter, however, there are static limitations for a tubular tower structure consisting of corresponding tubular tower segments with regard to the maximum tower height and/or the maximum weight that can be taken up on the tower head, for example the weight of the nacelle and the rotor of a wind turbine.

In particular, in order to enable higher towers for wind turbines to utilise the wind prevailing at higher altitudes, it is known to form at least part of the tubular tower segments of a corresponding tubular tower structure from longitudinally oriented shells, which are individually transported to the installation site of the wind turbine and only there are assembled to an annular tube segment. By transporting the shells individually, the diameter of the assembled tubular tower structure is no longer limited by the clearance height of bridges, for example, but can be selected to be significantly larger. It is only necessary to design the individual shells so that they can be transported to the installation site without any problems. In particular, the number of shells to form the complete tubular tower segment can also be selected such that the dimensions of the individual shells allow easy transport.

Various methods for assembling the shells to form a tubular tower segment are known in the prior art. In addition to the mounting of the tubular tower segment in the horizontal state, in which the individual shells are mounted one after the other while the tubular tower segment or its already installed shells are rotatably placed on an auxiliary scaffold so that the tubular tower segment must then be erected for the actual mounting, methods are also known in which the tubular tower segment is mounted directly upright. However, the corresponding methods either require a complex and cost-intensive installation platform (cf. for example, WO 2012/007226 A2), or else the alignment of the individual shells to one another so that they can be connected to one another is difficult. The document US 2015/0176299 A1 discloses a method for erecting a tower of a wind turbine, in which the individual tower segments are composed by ring segment-shaped panels. First, two opposite panels of a tower segment are connected to a unit by a connecting structure, which is then lifted as a whole onto the tubular tower foundation or an already erected tubular tower segment. Then the missing panels are added by erecting them and connecting them directly to the adjacent panels that have already been erected. The disadvantage of this is the requirement for a complex connecting structure, which must be designed for lifting and erecting two panels connected above it.

It is an object of the present invention to provide a method for mounting an annular tubular tower segment from at least three ring segment-shaped panels, and a mounting aid which is particularly suitable therefor, by means of which the disadvantages of the prior art can at least be reduced.

This problem is solved by a method according to the main claim, and a mounting aid according to the associated claim. Advantageous further developments are the subject matter of the dependent claims.

Accordingly, the invention relates to a method for mounting an annular tubular tower segment from at least three ring segment-shaped panels on a horizontally oriented, annular erection aid which is designed for receiving the lower end of the tubular tower segment, comprising the steps:

- a) Erecting a first ring segment-shaped panel with its underside on the erection aid;
- b) Erecting a second ring segment-shaped panel with its underside on the erection aid;
- c) Connecting the upper sides of the first and second panel to a mounting support, with the result that the two panels are mutually supported via the mounting support;

- d) Erecting a further panel adjacent to an already erected panel with its underside on the erection aid;
- e) Connecting the further panel at its upper side to the mounting support via an orienting aid, wherein the orienting aid is constituted by pivotable positioning arms fastened on the mounting support;
- f) Connecting the further panel to the adjacent panel(s);
- g) Repeating steps (d) and (e) until the tubular tower segment is complete; and
- h) Removing the mounting support.

10 The invention further relates to a mounting aid for use in the mounting method according to the invention, having a mounting support with at least one pair of spaced-apart attachment points for fastening to the upper side of the first and second panels of an annular tubular tower segment to be constructed from more than three ring segment-shaped panels and a central region located in between, wherein pivotable support arms are provided at the central region as an orienting aid for the further panels.

In the method according to the invention, the annular tubular tower segment is composed of several panels immediately in the erected state, that is to say with the tower axis oriented vertically. In addition to an annular erection aid, only one mounting support is required, which can be designed, for example, as a mounting aid according to the invention.

The erection aid is designed for receiving the lower end of the tubular tower segment to be mounted. For this purpose, the erection aid has, for example, a receptacle adapted to the shape of the lower end of the tubular tower segment to be mounted, wherein this functions as a correspondingly shaped depression or as projections or pins (with or without thread) designed for engaging in openings (for example through holes in a flange) on the underside of the tubular tower segment or its panels. As an alternative or in addition, it is also possible for the erection aid for receiving the lower end of the tubular tower segment or its panels to be designed such that the panels can be detachably attached to the erection aid, for example by screwing. The erection aid can be designed as a correspondingly designed, separate mounting template. Due to the described structural requirements for the erection aid, it is also possible to use the tubular tower foundation directly as an erection aid for the lowest tubular tower segment of the tower structure to be

erected, which means that subsequent offset of the mounting of the tubular tower segment to the foundation can be dispensed with. In the case of the further tubular tower segments, the already mounted tubular tower segment, which is arranged under the tubular tower segment to be mounted, can be used as an erection aid, wherein, for example, a connection flange on the upper side of the lower, already mounted tubular tower segment or a connecting element (such as a torsion ring or an annular flange adapter) arranged thereon for connection to the tubular tower segment above it then forms the actual erection aid.

In a first step, a first ring segment-shaped panel is erected with its underside on the erection aid. Depending on the design of the erection aid, the first panel can also be connected to the erection aid. Depending on the design of the panel and/or the erection aid or a possible connection between the panel and erection aid, the first panel is already held in the position which the first panel also occupies in the fully mounted tubular tower segment. If necessary, a separate support and/or bracing can also be provided for this.

Then a second annular panel is erected on the erection aid with its underside. If necessary, this panel can also be held in the desired position via a support and/or bracing. The second panel is preferably a panel essentially opposite the first panel, i.e. the number of further panels required for the two spaces between the first and second panels differs by only one or is identical. The former case applies in particular to the cases in which the tubular tower segment is formed by an odd number of panels, while the latter case is preferred for a tubular tower segment with an even number of panels.

The two panels, i.e. the first and the second panel, are then connected to a mounting support so that the two panels are supported by the mounting support. After installation of the mounting support provided according to the invention, separate support and/or bracing of the first and/or second panel is no longer necessary.

The panels of the tubular tower segment can each have connection flanges on their upper side and lower side. The mounting support can then be connected to the connection flanges on the upper sides of the two panels. The mounting support can be connected directly to the connection flanges, for example via screwing. However, it is also possible for annular flange adapter segments respectively to be arranged between the connection flanges on the upper sides of the first and

second panels and the mounting support. These annular flange adapter segments can be attached to the first and second panels before they are erected. After all the panels of the tubular tower segment have been mounted, the annular flange adapter segments can be completed by further annular flange adapter segments to form an annular flange adapter.

5

The mounting support may have devices to ensure that the upper sides of the first and second panels are at a predetermined distance from one another. These devices can be guides or actuators with which the desired position of the two panels can be secured or adjusted. The mounting support can also have a spirit level so that the correct position and alignment of the two panels can be easily checked.

10

Then another panel, which is adjacent to a panel that has already been erected, is erected with its underside on the erection aid and then connected to the adjacent panel(s). The connection of two adjacent panels is preferably carried out by screwing on vertical flanges aligned radially to the axis of the tubular tower segment. However, it is also possible to connect the panels to one another in a different manner, for example by welding.

15

In order to facilitate the alignment of the further panel before it is connected to the adjacent panel(s), it is provided that the further panel is first connected to the mounting support on its upper side via an orienting aid. The orienting aid is at least one positioning arm which is pivotably attached to the mounting support and can be connected to the upper side by pivoting such that the position of the further panel relative to the mounting support, and thus relative to the first and second panels, can be secured. If the panels have connection flanges on their upper side, the positioning arms can engage in the through holes provided there. If the positioning arm is still length-adjustable, the position of the further panel can be corrected if necessary in order to be able to compensate for manufacturing tolerances.

20

25

The number of positioning arms is preferably equal to or greater than the number of further panels, that is to say the number of all panels of the tubular tower segment minus the first and second panels. In addition, a circumferential support circle can be provided as an orienting aid, against which the further panels can be leaned. By means of an appropriate orienting aid, the final position of the further panel can be determined even before it is connected to adjacent panels, which consistently facilitates the establishment of the connection mentioned.

30

In order to facilitate the connection of two adjacent panels and in particular to be able to avoid complex scaffolding constructions, it is provided to use an at least vertically movable work platform connected to the mounting support, with which the connection regions of two adjacent panels can be moved vertically in order to establish the desired connection. In order to be able to use the work platform variably for each connection between adjacent panels, it is preferred if the work platform is rotatable about the axis of the tubular tower segment or is movable on a circular path about this axis. In the case of conically shaped tubular tower segments in particular, it is advantageous if the work platform is movable or extendable in the radial direction to the axis of the tubular tower segment. This can ensure that, particularly in the case of conically shaped tubular tower segments, the connection regions of two adjacent panels can be easily reached from the work platform over the entire height of the tubular tower segment.

Once all the panels of the tubular tower segment have been erected on the erection aid and each connected to the adjacent panels, the mounting support can be removed from the tubular tower segment, possibly together with elements arranged thereon, such as a work platform. For this purpose, the mounting support can in particular be lifted upwards from the tubular tower segment. If the tubular tower segment still has to be lifted from the erection aid to the final installation site after mounting, the mounting support can also serve as a transport aid, for example by a crane acting on the mounting support to lift the tubular tower segment.

If necessary, the annular flange adapter, if for example annular flange adapter segments are already provided between the mounting support and connection flanges on the upper side of the first and two panels, can be completed by further annular flange adapter segments before or after removal of the mounting support. If this is not the case, a single or multi-part annular flange adapter or another adapter can be attached to the upper side of the tubular tower segment after removal of the mounting support, if necessary.

The mounting aid according to the invention is designed for use in the method according to the invention, which is why reference is made to the above statements for the explanation of the mounting aid.

The mounting aid comprises a mounting support which has at least one pair of spaced-apart attachment points for fastening to the upper side of the first and second panels of an annular tubular tower segment to be constructed from more than three ring segment-shaped panels. The central region of the mounting support is located centrally between the two attachment points of a pair. At this central region, the pivotable positioning arms are provided as an orienting aid for the further panels.

The number of positioning arms is preferably equal to or greater than the number of further panels (the number of all panels of the tubular tower segment minus the first and the second panel). As a result, all panels of a tubular tower segment can remain connected to the mounting support until the completion of the mounting and can be held in position, which facilitates the mounting of the individual panels.

In order to be able to use the mounting aid for different tubular tower segments with different diameters on their upper side, as is regularly the case, for example, with the tubular tower segments of a conical tower section formed from several tubular tower segments, a second pair of attachment points can be provided symmetrically around the central region, wherein the attachment points of this pair are at a different distance from one another than the at least one other pair of attachment points. The mounting aid can thus be used for tubular tower segments with at least two different diameters on their upper side. In this case, the positioning arms are preferably length-adjustable in order to be able to be adapted to the respective diameter of the tubular tower segment to be mounted.

It is preferred if a crossmember is rotatably attached to the central region of the mounting support, wherein the length of the crossmember is preferably less than the smallest distance between a pair of attachment points. The latter can ensure that the mounting aid can be pulled up out of this after completion of a tubular tower segment.

A work platform, which is movable vertically to the crossmember, is preferably attached to the crossmember. More preferably, the work platform is also movable horizontally along the crossmember and/or is extendable in a direction parallel to it. This movability or extendibility ensures that the connection regions of two adjacent panels can be easily reached from the work platform over the entire height of the tubular tower segment, even in the case of conically shaped

tubular tower segments. If, at least in the retracted state, the length of the work platform is also smaller than the smallest distance between a pair of attachment points, the mounting aid can still be removed upwards from a completed tube segment.

5 As an alternative to providing a crossmember, a circular path for a work platform can also be attached to the mounting support around the central region, wherein the diameter of the circular path is preferably smaller than the smallest distance between a pair of attachment points. The mounting aid can be removed upwards after the completion of the tubular tower segment. The circular path can also serve as a circumferential support circle, i.e. as an orienting aid for the panels.

10

A work platform is preferably attached to the circular path and is movable vertically to the circular path. More preferably, the work platform is extendable in the radial direction to the axis of the circular path. This extendibility ensures that the connection regions of two adjacent panels can be easily reached from the work platform over the entire height of the tubular tower segment, even
15 in the case of conically shaped tubular tower segments. If the work platform is also designed accordingly, at least in the retracted state, the mounting aid can also be removed with the work platform upward from a completed tube segment.

20

The panels of the tubular tower segment to be mounted according to the method according to the invention are preferably made of sheet steel. The sheet steel can have a thickness of 26 mm and 100 mm, preferably from 30 mm to 50 mm. At least part of the flanges of a panel can be formed by folding the sheet steel.

25

The tubular tower segments to be mounted preferably have a diameter of greater than 4.5 m, more preferably of 7 m or more. The diameter relates to the largest diameter of a tubular tower segment, that is, in the case of conically shaped tubular tower segments, to the larger of the two diameters on the upper side and lower side.

30

The height of the tubular tower segment to be mounted can be 10 m or more, preferably 20 m or more.

The invention will now be described by way of example with reference to advantageous embodiments with reference to the accompanying drawings. In the figures:

Figs. 1a-k: the individual steps of the method according to the invention with a first embodiment of a mounting aid according to the invention;

5 Figs. 2a, b: Detailed representations of Figures 1a-k;

Figs. 3a, b: a second embodiment of a mounting aid according to the invention; and

10 Figs. 4a-c: an embodiment of a preferred work platform for the mounting aid according to Figures 1a-k, 2a, b or 3a, b.

The individual method steps of the method according to the invention for the mounting of annular tubular tower segments 1, 2 each consisting of ten ring segment-shaped panels 10, 11, 12, 20, 21, 22 are explained on the basis of the Figures 1a to 1k. Both tubular tower segments 1, 2 are conically
15 shaped.

For mounting the first tubular tower segment 1, a first erection aid 30 is provided, which is designed for receiving the underside of the first tubular tower segment 1 or its ring segment-shaped panels 10, 11, 12. The first erection aid 30 is the foundation of the tubular tower structure to be erected
20 with the aid of the tubular tower segment 1 as a tower for a wind turbine. On the upper side of the erection aid 30, threaded pins 31 protrude, to which the panels 10, 11, 12 can be attached. For this purpose, the panels 10, 11, 12 each have horizontally erected connection flanges 13, 14 on their upper sides and lower sides for a corresponding connection. In addition, vertical flanges 15 are provided on the two remaining edges of the panels 10, 11, 12, via which two adjacent panels 10,
25 11, 12 of the tubular tower segment 1 can be connected to one another. The panels 10, 11, 12 are made of sheet steel, wherein the vertical flanges 15 are formed by folding the steel sheet and the connection flanges 13, 14 are formed by welded components.

As shown in Fig. 1a, a first panel 11 of the first tubular tower segment 1 is first erected on the
30 erection aid 30. For this purpose, the panel 11 is placed on the threaded pins 31 of the mounting aid 30 at the position of the first panel 11 which is ultimately desired in the completed tubular tower segment 1 and secured there with nuts. If the screw connection on the mounting aid 30 is

not sufficient to temporarily secure the position of the first panel 11, a bracing 32 can alternatively be provided.

5 The upper side of the first panel 11 has an annular flange adapter segment 16 connected to the connection flange 13 arranged there.

10 In the next step (cf. Fig. 1b), the second panel 12 opposite the first panel 11 is erected on the erection aid 30 and screwed there. If necessary, the second panel 12 can also be secured in its position by a bracing 32. The second panel 12 also has an annular flange adapter segment 16 on its upper side.

15 Subsequently (cf. Fig. 1c), the upper sides of the first and second panel 11, 12 are connected to one another via a mounting support 41 in such a way that the two panels 11, 12 are mutually sufficiently supportive such that the bracing 32 (cf. Figs. 1a, 1b) is no longer required and can be removed. The mounting support 41 is part of a mounting aid 40 and is firmly connected to the connection flanges 13 on the upper sides of the first and second panels 11, 12 via the annular flange adapter segments 16. For this purpose, the mounting support 41 has a pair of attachment points 42, wherein one attachment point 42 each is arranged in the region of one end of the mounting support (cf. also detailed illustration in Fig. 2). Based on the defined attachment points 42, it is ensured that the two
20 panels 11, 12 are in the position relative to one another that is desired for the further mounting of the tubular tower segment 1.

25 The central region 43 of the mounting support 41 is in the middle between the two attachment points 42 of the mounting support 41. At this central region 43, eight pivotable positioning arms 44 are provided as an orienting aid for the further panels 10, i.e. the panels to be erected after the first and second panels 11, 12. After another panel 10 has been erected on the erection aid 30, a positioning arm 44 can be pivoted down and brought into engagement with the connection flange 13 on the upper side of the further panel 10 in order to align this panel 10 with the erected panels 10, 11, 12 (see Figure 2a). The positioning arms 44 are adjustable in length in order to be able to
30 compensate for any manufacturing tolerances. The number of positioning arms 44 corresponds to the number of further panels 10, namely eight.

Furthermore, a crossmember 45 is fastened to the central region 43 of the mounting support 41 so as to be rotatable about a vertical axis, wherein the length of the crossmember 45 is smaller than the distance between the two attachment points 42 of the mounting support 41. A work platform 46, which is vertically movable, is in turn arranged on the crossmember 45. The work platform 46 is designed according to Figs. 4a-c, from which it can be seen immediately that the work platform 46 is designed to be extendable in its longitudinal direction. This extendibility offers the advantage that the vertical flanges 17 of the panels 10, 11, 12 can be easily reached from the work platform 46 at any height of the conically shaped tubular tower segment 1. In the retracted state (Fig. 4 a), however, the length of the work platform 46 is less than the distance between the two attachment points 42 of the mounting support 41.

Subsequently, further panels 10 are gradually erected on the erection aid and connected to each with adjacent panels 10, 11, 12 already erected along the vertical flange 17 by screwing (see Figs. 1d and 1e). In order to facilitate the production of the screw connection, each newly erected panel 10 can first be connected to the mounting support 41 via a positioning arm 44 (cf. Fig. 2a) and, if necessary, adjusted using its length adjustability in such a way that the holes provided for the screw connection in the vertical flanges 17 are aligned. The screw connection itself can be produced from the work platform 46, which for this purpose can lower the vertical flanges 17 in height and, if necessary, can be extended lengthwise in order to be able to easily reach the vertical flanges 17 over their entire length.

It is possible that individual panels 10 already have attachments 18 or door cut-outs 19 during the mounting of the tubular tower segment 1.

Once all the panels 10, 11, 12 have been erected and connected to one another, the annular flange adapter segments 16 already present on the upper side of the panels 10, 11 are supplemented by further annular flange adapter segments 16' to form a complete annular flange adapter (see Fig. 2b) on which another tubular tower segment 2 can be attached.

The second tubular tower segment 2 is mounted essentially analogously to the first tubular tower segment 1. Instead of mounting directly on a foundation as an erection aid 30, however, the mounting is carried out on a separate mounting template as an erection aid 35. As an alternative

to this, the second tubular tower segment 2 can also be mounted directly on the first tubular tower segment 1 which has already been erected on the foundation.

5 Even if the mounting of the second tubular tower segment 2 on the separate erection aid 35 is shown below in Figs. 1a-k as the mounting of the first tubular tower segment 1, the mounting of the second tubular tower segment 2 can also be carried out simultaneously with that of the first tubular tower segment 1.

10 When mounting the second tubular tower segment 2, the first and second panels 21, 22 are first erected on the erection aid 35 and connected to one another by the mounting support 41 of a mounting aid 40', wherein no annular flange adapter segments are provided between the panels 21, 22 and mounting support 41 (Fig. 1f). The mounting aid 40' is designed analogously to the mounting aid 40 for the first tubular tower segment 1 and is only adapted to the different dimensions of the second tubular tower segment 2. Furthermore, reference is made to the above
15 explanations regarding the mounting aid 40.

The mounting of the further panels 20 of the second tubular tower segment 2 also proceeds analogously to the mounting of the further panels 10 (Fig. 1g), which is why reference is also made here to the above explanations.

20

In a next step (cf. Fig. 4h), the mounting aid 40 for the first tubular tower segment 1 is removed. Since the length of both the crossmember 45 and the work platform 46, at least in the retracted state, is less than the distance between the two attachment points 42 on the mounting support 41, the mounting aid 40 together with the work platform 46 can be removed upward from the first
25 tubular tower segment 1.

25

Subsequently, the second tubular tower segment 2 as a whole can be lifted from the mounting template or erection aid 35 and placed on the first tubular tower segment 1 and screwed to it or to the annular flange adapter arranged on the upper side of the first tubular tower segment 1 and fastened in this way (see Fig. 1i). In this case, the second tubular tower segment 2 can be raised
30 using the mounting aid 40, i.e. a crane provided for this purpose engages on the mounting aid 40 and not directly on the tubular tower segment 2.

30

The mounting aid 40' can then also simply be removed upwards, since here too the length of the crossmember 45 or the work platform 46, which may be completely retracted, is less than the distance between the two attachment points 42 on the mounting support 41 (see Fig. 1j).

5 Finally, an adapter module 50 is mounted (see Fig. 1k) on which further tubular tower segments (not shown) can be arranged, wherein these further tubular tower segments can in particular be tubular components of prefabricated tubular tower segments with a maximum diameter of 4.5 m.

10 In the exemplary embodiment shown, the first tubular tower segment 1 has a lower diameter of 9.6 m and an upper diameter of 7.1 m. The second tubular tower segment 2 has a corresponding lower diameter and an upper diameter of 4.6 m. The adapter module 50 further reduces this diameter to 4.5 m.

The height of the tubular tower segments 1, 2 is in each case 20 m in the illustrated embodiment.
15 The individual panels 10, 11, 12, 20, 21, 22 are made of sheet steel with a thickness of 45 mm.

Figs. 3a, b show an alternative embodiment of a mounting aid 40'' according to the invention.

20 The mounting aid 40'', like the mounting aids 40, 40' from Figs. 1a-k and 2a, b, has a mounting support 41 with a pair of attachment points 42. The central region 43 of the mounting support 41, on which pivotable and length-adjustable positioning arms 44 are arranged, is located in the centre between the attachment points 42.

25 Instead of a crossmember 45 (cf. Figs. 1a-k and 2a, b), the mounting aid 40'' according to Figs. 3a, b, has a circular path 47 arranged around the central region 43 of the mounting support 41. The diameter of the circular path 47 is smaller than the distance between the two attachment points 42. The mounting aid 40'' can thus continue to be removed upward from a tubular tower segment 1, 2 which is completed with the aid thereof. At the same time, the circular path 47 can be used in addition to the positioning arms 44 as an additional orienting aid for the panels 10, 11, 12, 20, 21,
30 22 in the form of a circumferential support circle.

A work platform 48 is also arranged on the circular path 47 and is movable both along the circular path 47 and in the vertical direction. Furthermore, the work platform can be extended in the radial

direction to the axis of the circular path or to the tube tower axis in such a way that even in the case of conically shaped tubular tower segments 1, 2, the connection regions of two adjacent panels 10, 11, 12, 20, 21, 22 can be easily reached over the entire height of the tubular tower segment 1, 2.

Patentkrav

- 1.** Fremgangsmåde til montering af et ringformet rørtårnsegment (1, 2) bestående af mindst tre ringsegmentformede paneler (10, 11, 12, 20, 21, 22) på en horisontalt tilpasset, ringformet opstillingsstøtte (30, 35), som er udformet til at modtage den nedre ende af rørtårnsegmentet (1, 2), med følgende trin:
- a) opstilling af et første ringsegmentformet panel (11, 21) med undersiden på opstillingsstøtten (30, 35);
 - b) opstilling af et andet ringsegmentformet panel (12, 22) med undersiden på opstillingsstøtten (30, 35);
 - c) forbindelse af oversiderne af det første og andet panel (11, 12, 21, 22) med en monteringsbærer (41), således at de to paneler (11, 12, 21, 22) er gensidigt støttet af monteringsbæreren;
 - d) opstilling af et yderligere panel (10, 20) ved siden af det ene allerede opstillede panel (10, 11, 12, 20, 21, 22) med undersiden på opstillingsstøtten (30, 35);
 - e) forbindelse af det yderligere panel (10) på dets overside via en tilpasningsstøtte med monteringsbæreren (41), idet tilpasningsstøtten består af drejelige opstillingsarme (44) fastgjort på monteringsstøtten (41);
 - f) forbindelse af det yderligere panel (10) med det eller de tilstødende panel(er) (10, 11, 12, 20, 21, 22);
 - g) gentagelse af trin (d) og (e) indtil rørtårnsegmentet (1, 2) er komplet; og
 - h) fjernelse af monteringsbæreren (41).

2. Fremgangsmåde ifølge krav 1,

kendetegnet ved, at

opstillingsarmene (44) er længde-justerbare.

3. Fremgangsmåde ifølge et af de foregående krav,

kendetegnet ved, at

forbindelsen af to tilstødende paneler (10, 11, 12, 20, 21, 22) udføres ved sammenskruning af to vertikale flanger (17) tilpasset radialt i forhold til

rørtårnsegmentets (1, 2) akse.

4. Fremgangsmåde ifølge et af de foregående krav,

kendetegnet ved, at

5 der til forbindelse af to tilstødende paneler (10, 11, 12, 20, 21, 22) anvendes mindst en vertikal bevægelig arbejdsplatform (46, 48) forbundet med monteringsbæreren (41), idet arbejdsplatformen (46, 48) fortrinsvis er drejelig om rørtårnsegmentets (1, 2) akse eller bevægelig om denne akse over en cirkelbane, idet arbejdsplatformen (46, 48) yderligere fortrinsvis er bevægelig
10 eller udskydelig i den radiale retning i forhold til rørtårnsegmentets (1, 2) akse.

5. Fremgangsmåde ifølge et af de foregående krav,

kendetegnet ved, at

panejerne (10, 11, 12, 20, 21, 22) har forbindelsesflanger (14) på deres overside,
15 og ringflangeadaptersegmenterne (16) er indrettet mellem henholdsvis forbindelsesflangerne (14) af de første og anden paneler (11, 12, 21, 22) og monteringsstøtten (41), og før eller efter fjernelsen af monteringsbæreren (41) afsluttes ringflangeadapteren via yderligere ringflangeadaptersegmenter (16).

20 **6.** Fremgangsmåde ifølge et af de foregående krav,

kendetegnet ved, at

opstillingsstøtten (30, 35) er en monteringskabelon, et rørtårnfundament eller et rørtårnsegment (1), som er indrettet under rørtårnsegmentet (2), som skal monteres.

25

7. Monteringsstøtte (40) til anvendelse i en monteringsfremgangsmåde ifølge et af kravene 1 til 6, med en monteringsstøtte (41) med mindst et par fastgørelsespunkter (42) adskilt fra hinanden til fastgørelse på oversiden af de første og anden paneler (11, 12, 21, 22) af et ringformet rørtårnsegment (1, 2)
30 som skal opbygges fra mere end tre ringsegmentformede paneler (10, 11, 12, 20, 21, 22), og med et midterområde (43) placeret centralt derimellem, idet der i midterområdet (43) er tilvejebragt drejelige opstillingsarme (44) som tilpasningsstøtte for de yderligere paneler (10, 20).

8. Monteringsstøtte ifølge krav 7,

kendetegnet ved, at

antallet af opstillingsarme (44) er lig med eller større end antallet af de yderligere paneler (10, 20).

5

9. Monteringsstøtte ifølge krav 7 eller 8,

kendetegnet ved, at

opstillingsarmene (44) er længde-justerbare.

10 **10.** Monteringsstøtte ifølge et af kravene 7 til 9,

kendetegnet ved, at

monteringsstøtten (40) har et andet par fastgørelsespunkter (42), som er indrettet symmetrisk om midterområdet (43), og som har en anden afstand fra hinanden end det første par fastgørelsespunkter (42).

15

11. Monteringsstøtte ifølge et af kravene 7 til 10,

kendetegnet ved, at

på monteringsbærerens (41) midterområde (43) er en travers (45) til en arbejdsplatform (46) drejeligt fastgjort, idet længden af traversen (45) fortrinsvis er mindre end den mindste afstand mellem et par fastgørelsespunkter (42).

20

12. Monteringsstøtte ifølge krav 11,

kendetegnet ved, at

der på traversen (45) er fastgjort en arbejdsplatform (46), som er bevægelig

25 vertikalt i forhold til traversen (45), idet arbejdsplatformen (46) fortrinsvis er

bevægelig horisontalt langs traversen (45) og/eller udskydelig i en retning parallel dermed.

13. Monteringsstøtte ifølge et af kravene 7 til 10,

30 **kendetegnet ved, at**

en cirkelbane (47) til en arbejdsplatform (48) er fastgjort på monteringsbæreren (41) om midterområdet (43), idet diameteren af cirkelbanen (47) fortrinsvis er mindre end den mindste afstand mellem et par fastgørelsespunkter (42).

14. Monteringsstøtte ifølge krav 13,

kendetegnet ved, at

der på cirkelbanen (47) er fastgjort en arbejdsplatform (48), som er bevægelig vertikalt i forhold til cirkelbanen (47), idet arbejdsplatformen (48) fortrinsvis er
5 udskydelig i den radiale retning i forhold til cirkelbanens (47) akse.

Fig. 1a

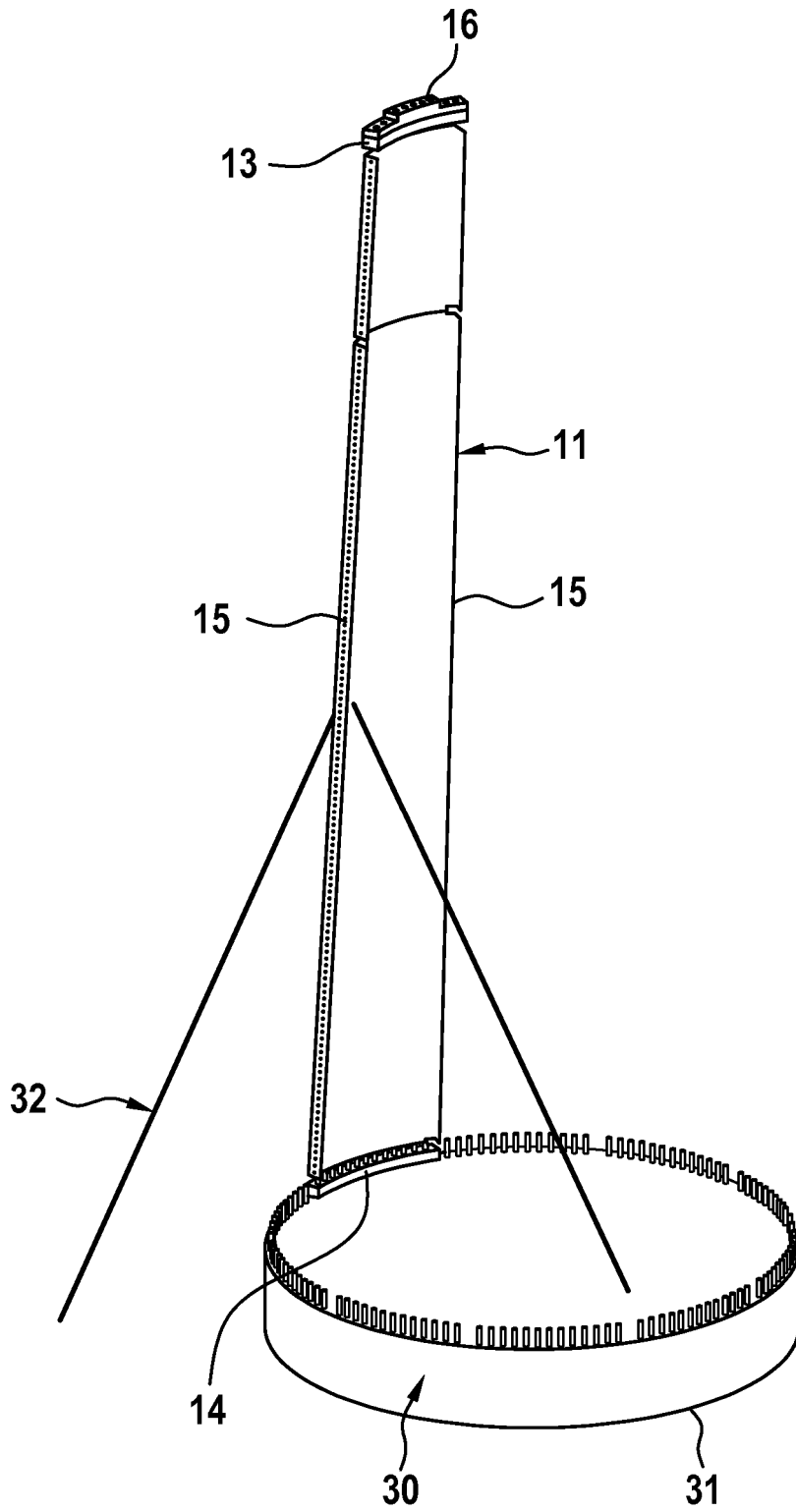
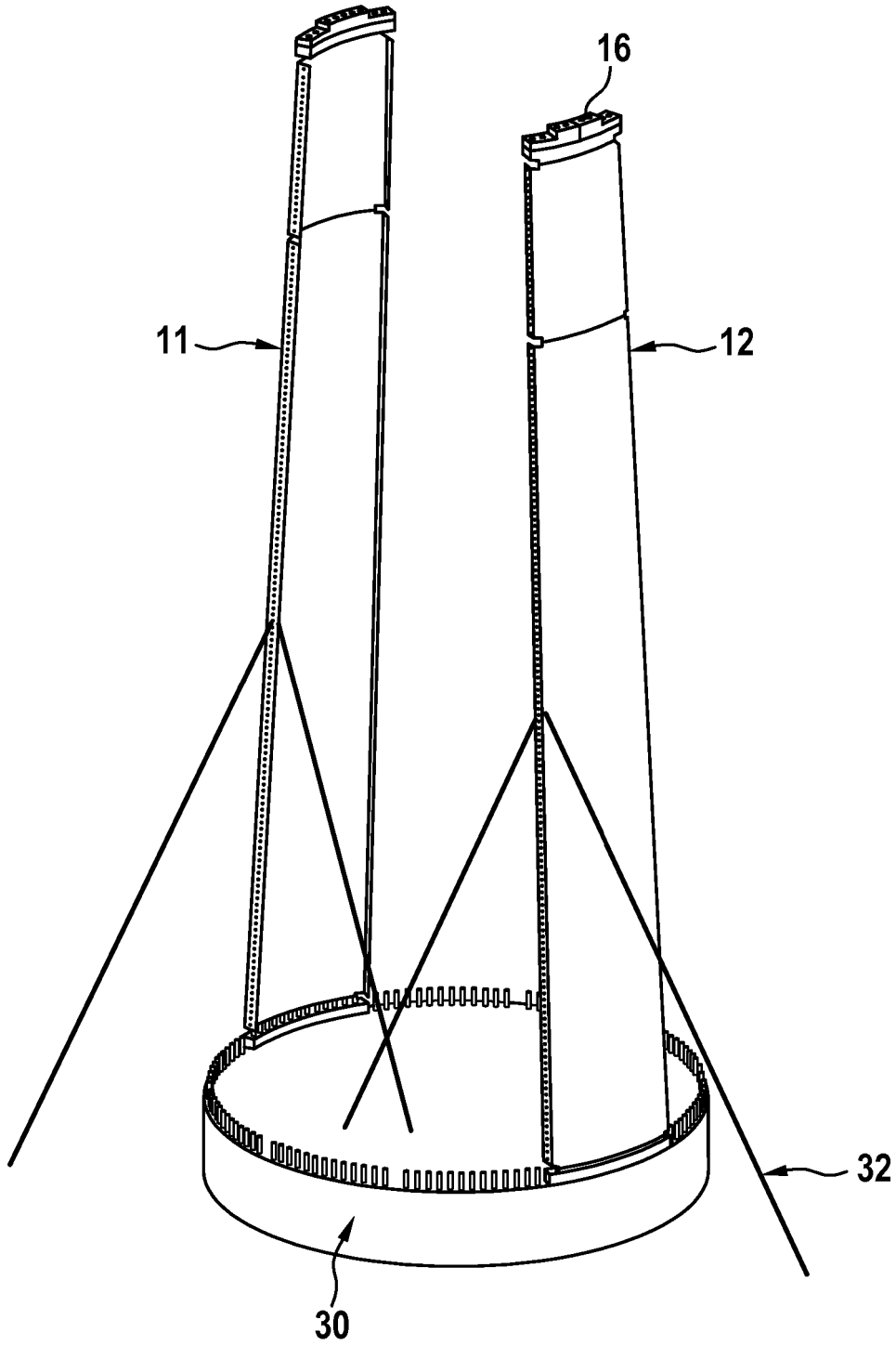

Fig. 1b



3 / 15

Fig. 1c

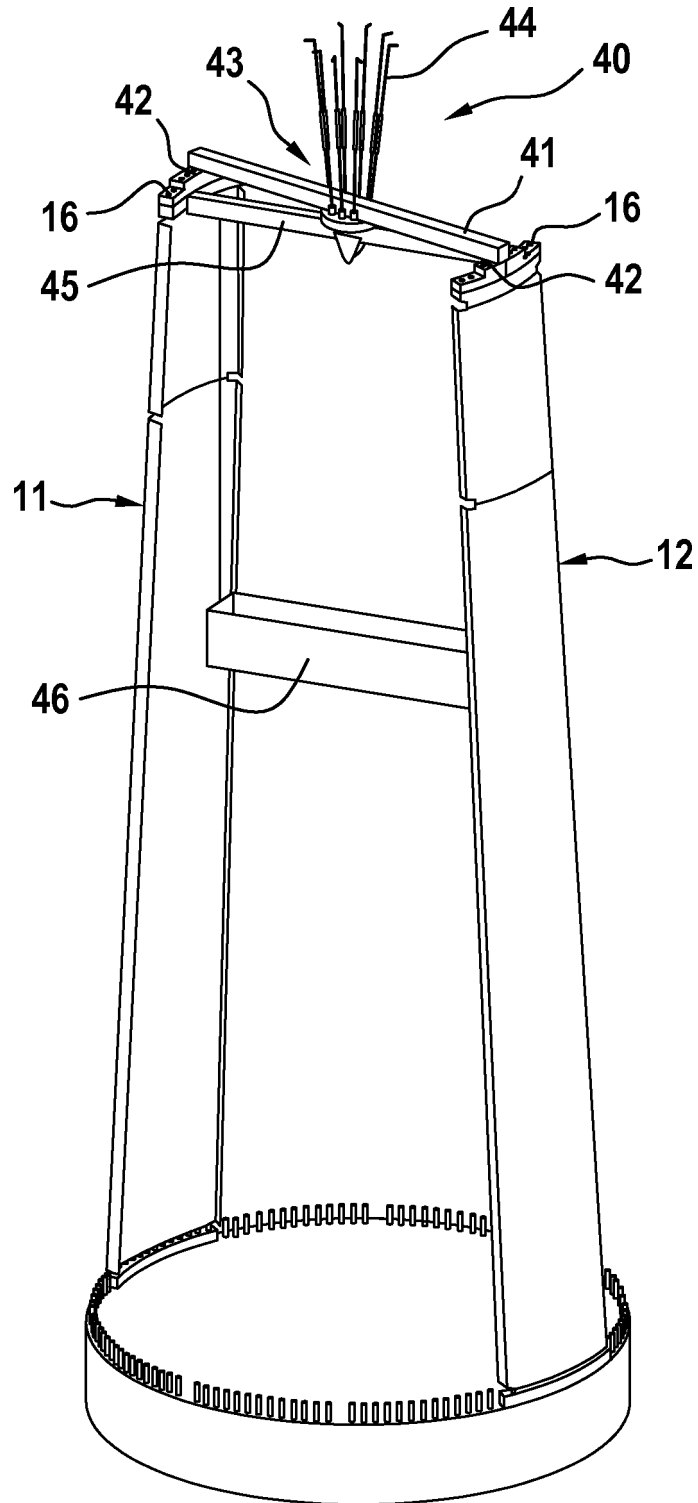

Fig. 1d

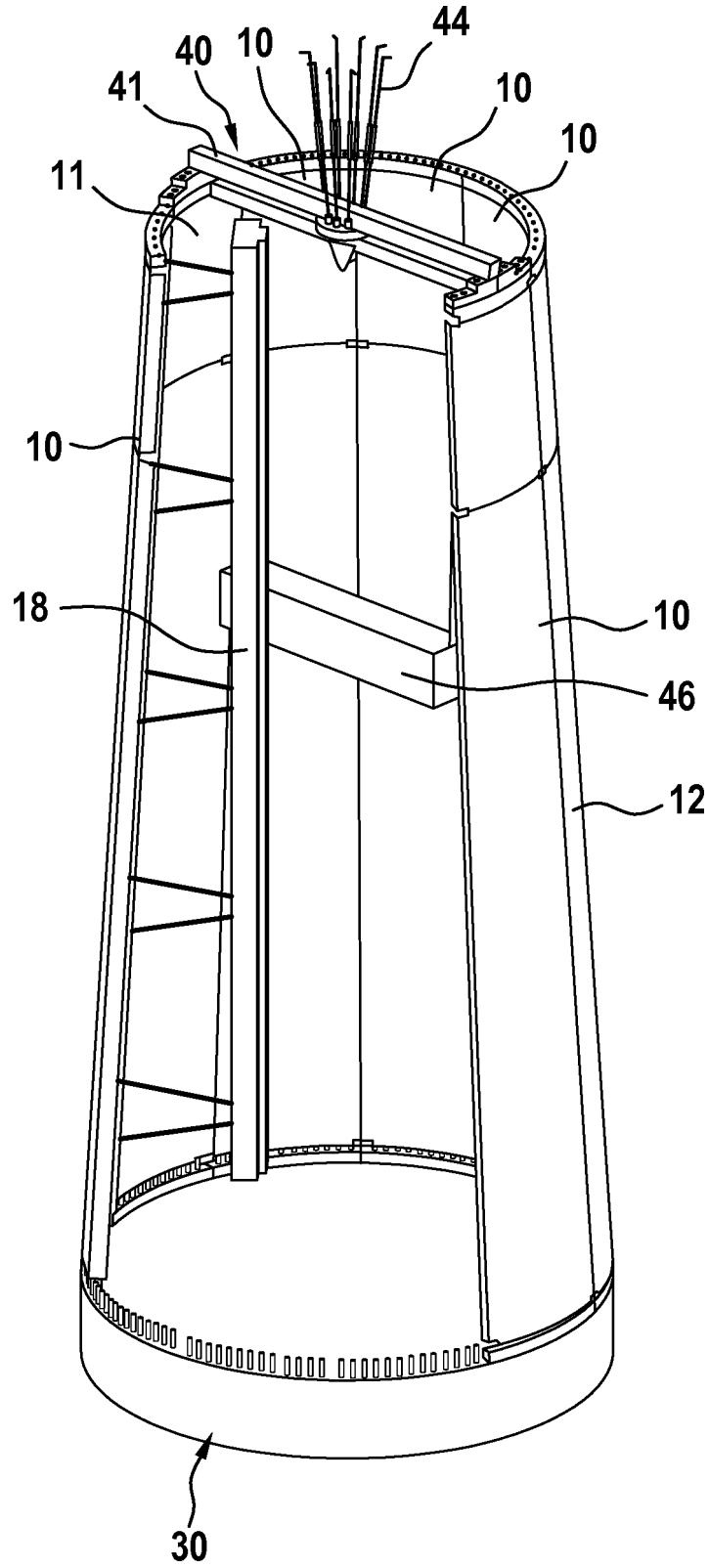

Fig. 1e

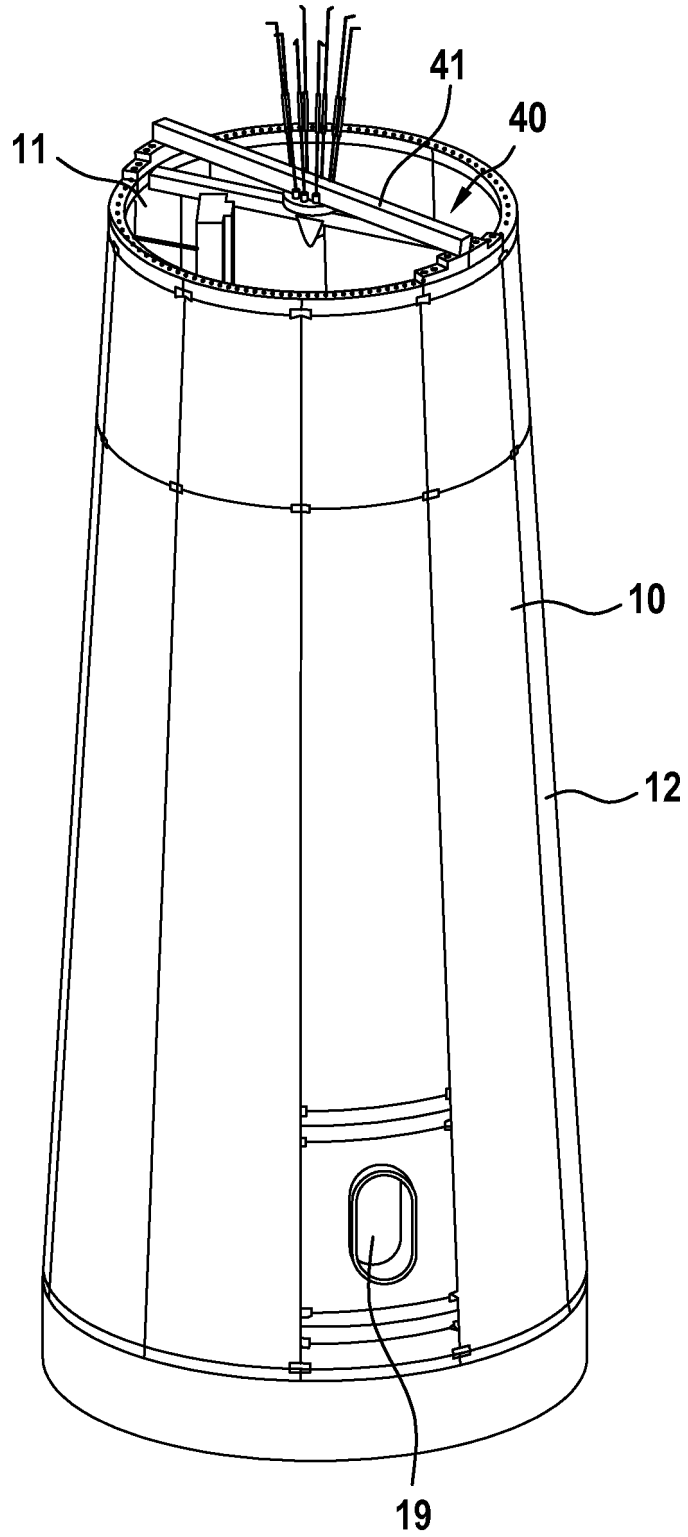

Fig. 1f

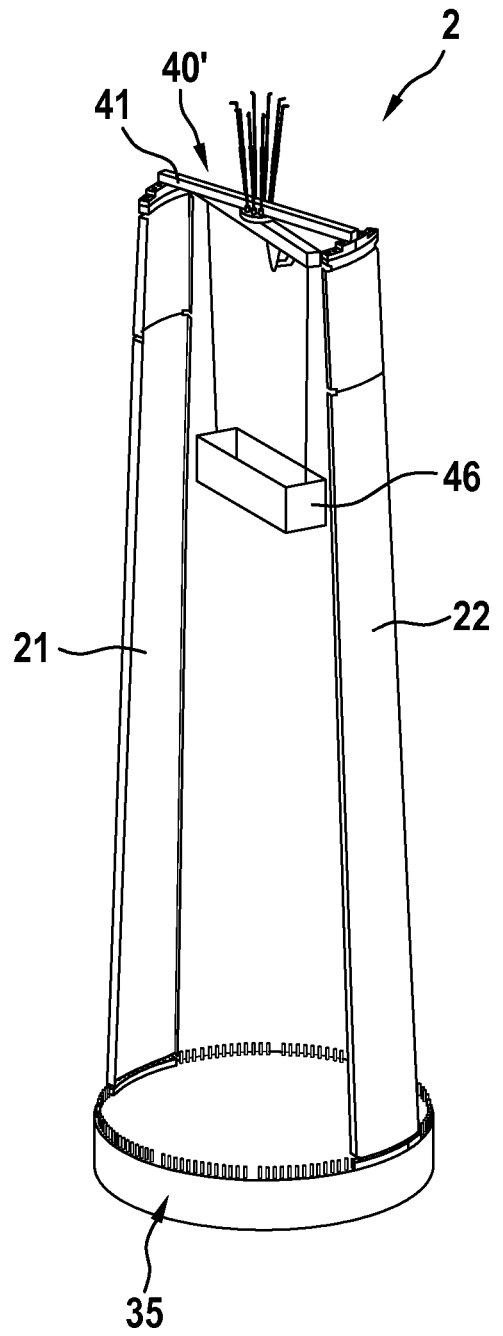
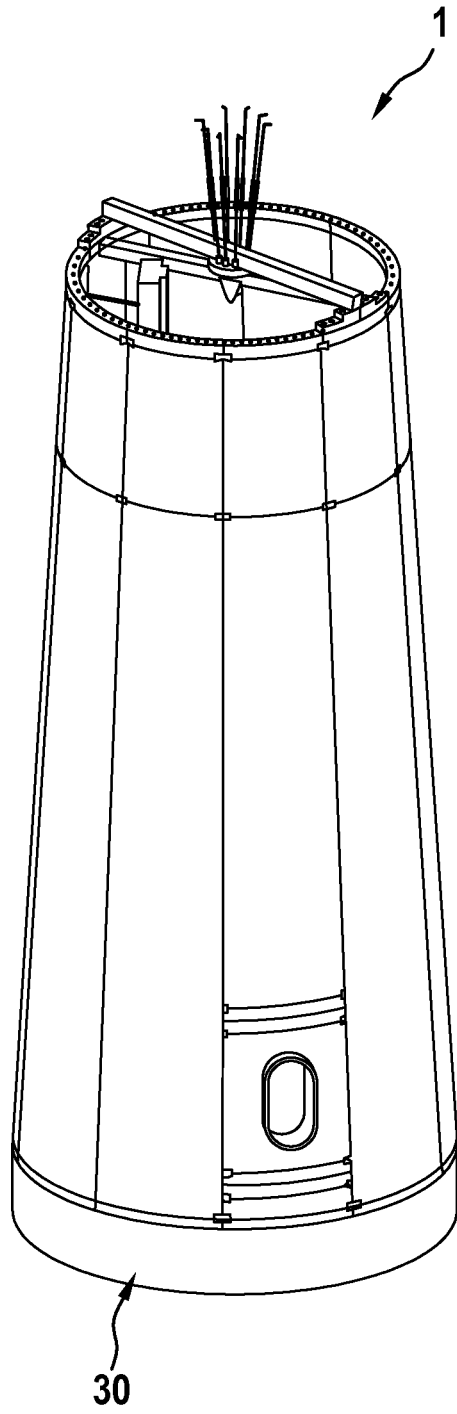

Fig. 1g

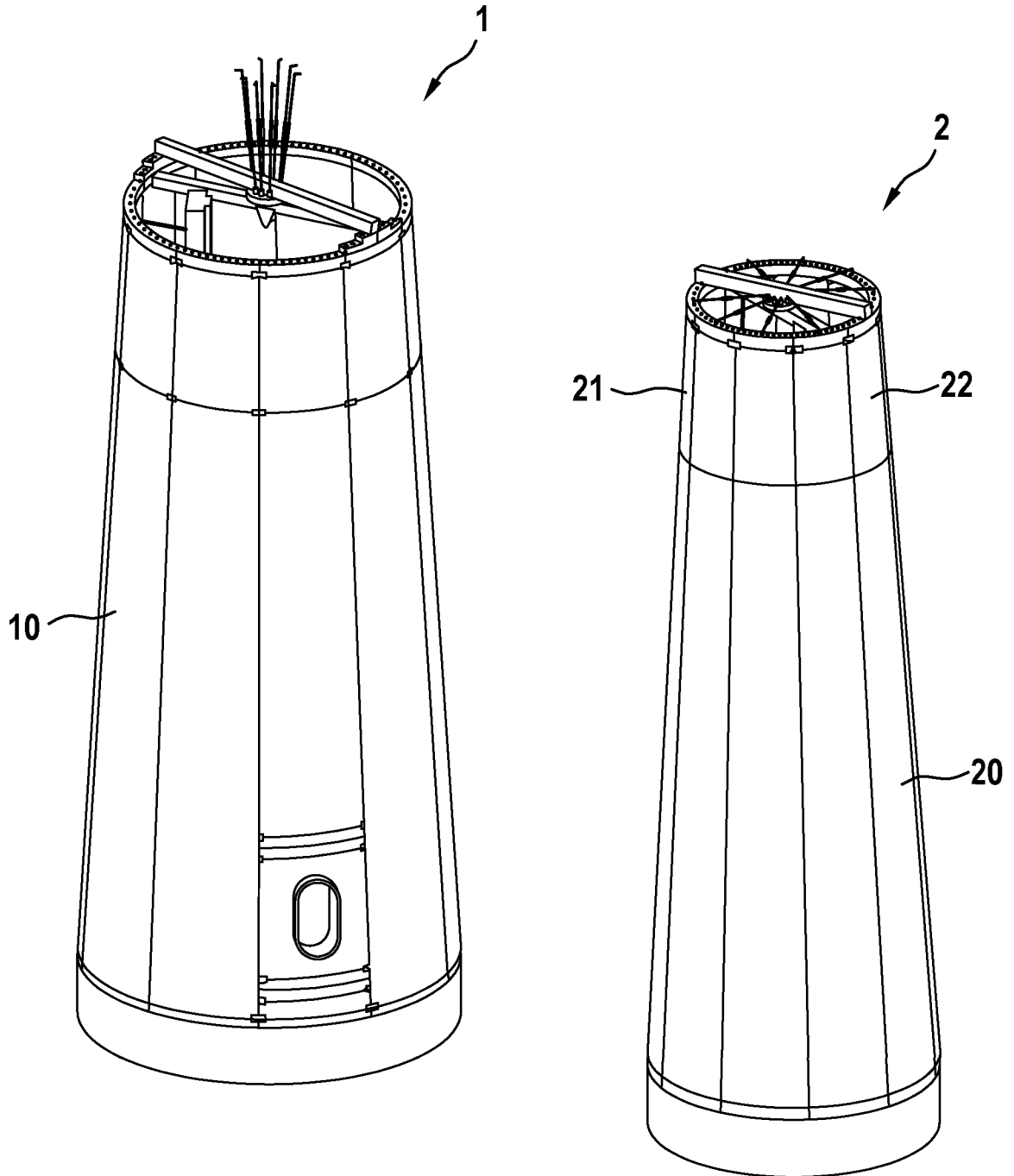

Fig. 1h

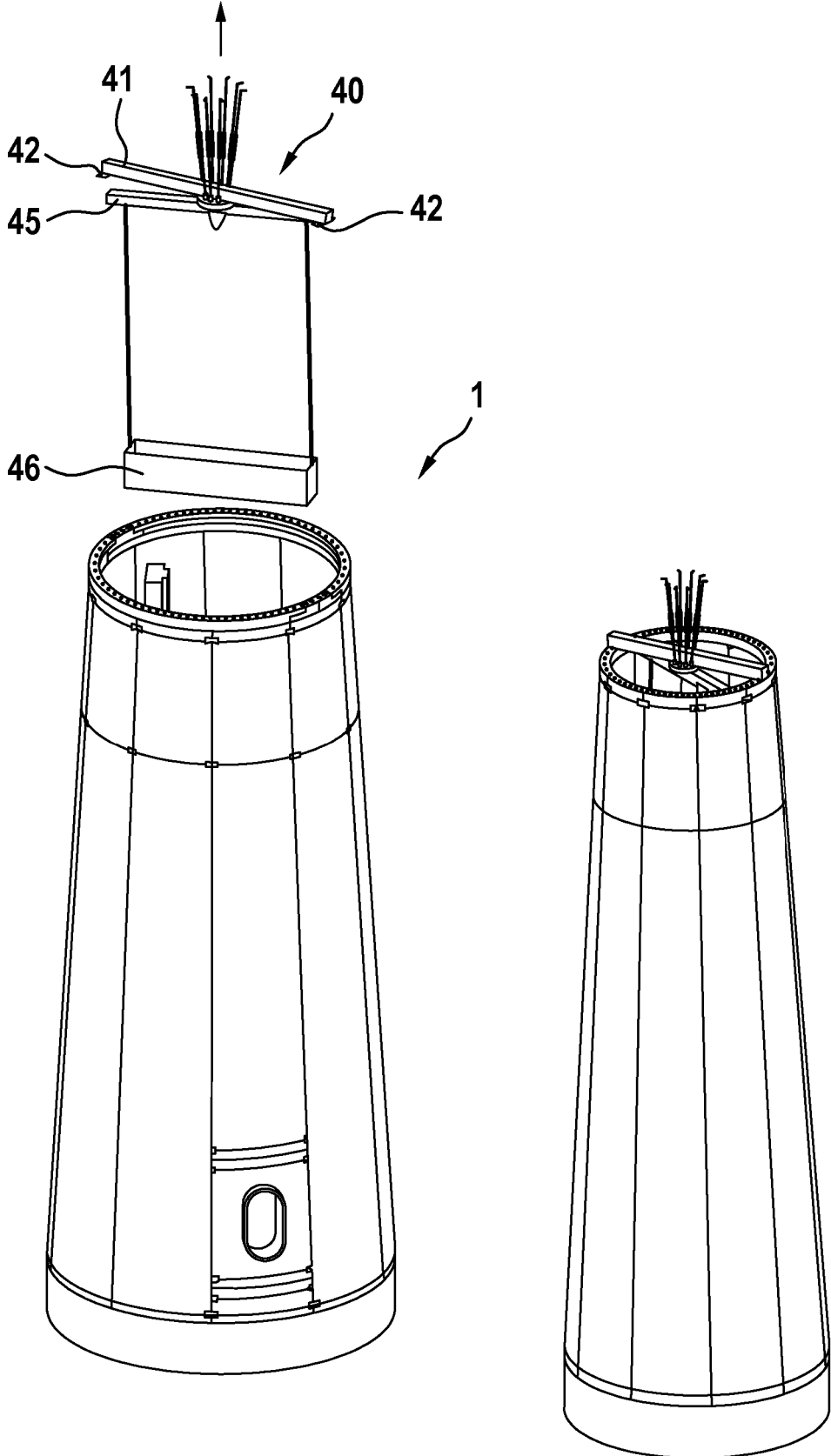
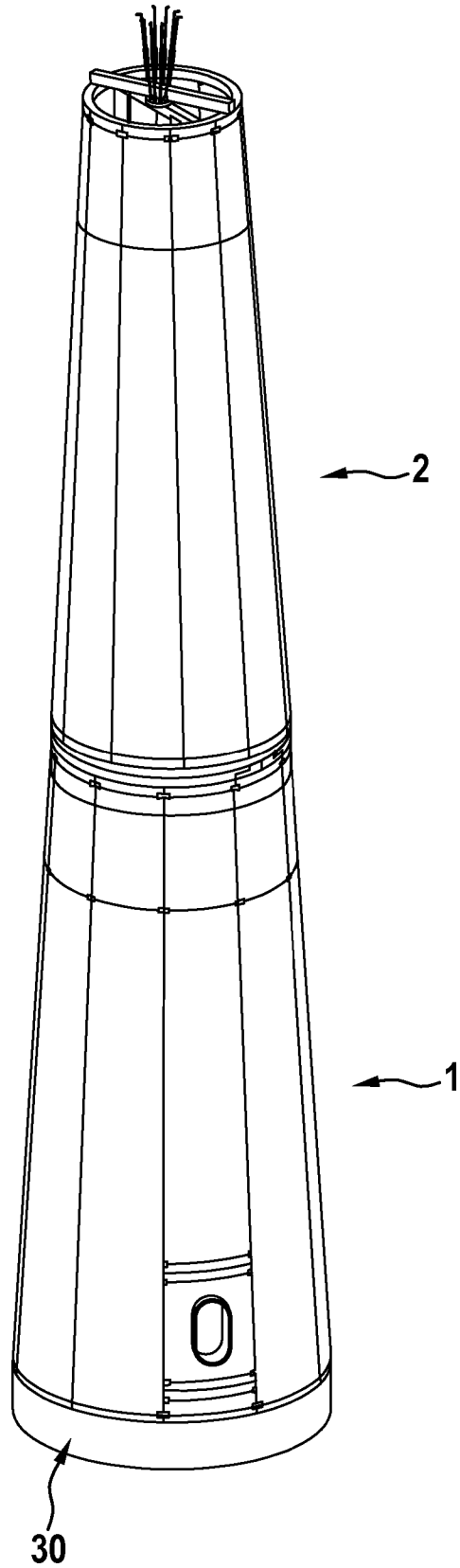

Fig. 1i



10 / 15

Fig. 1j

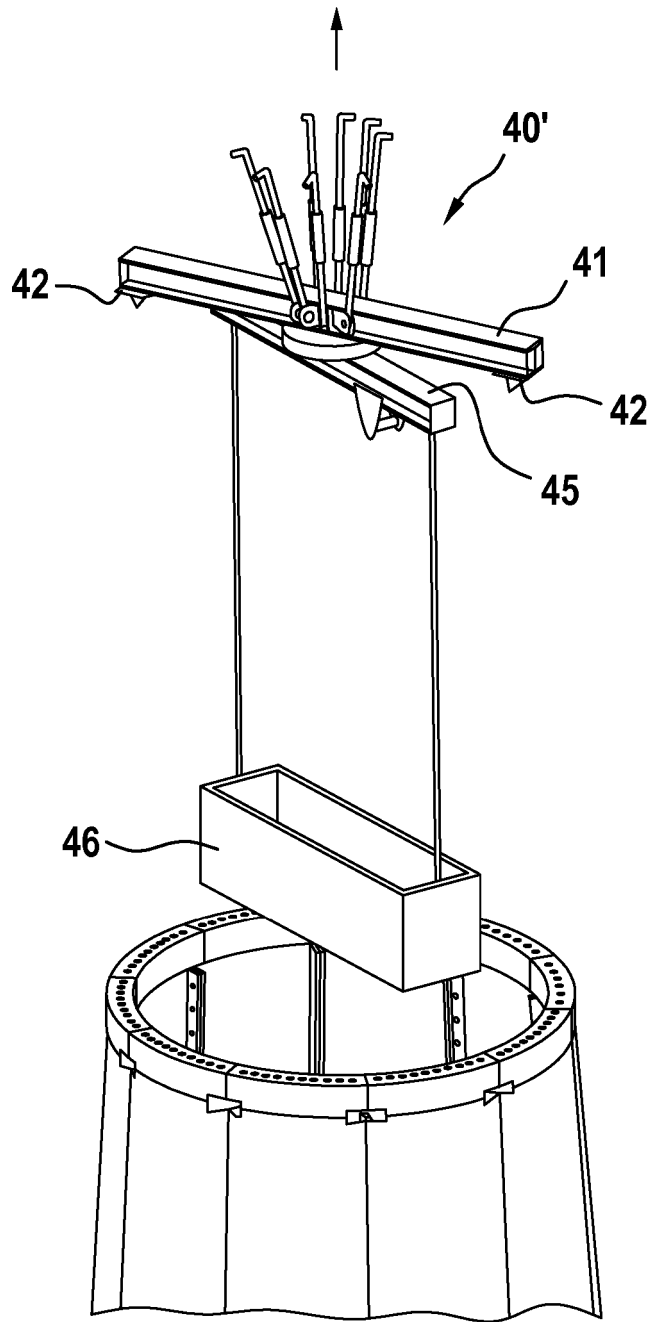

Fig. 1k

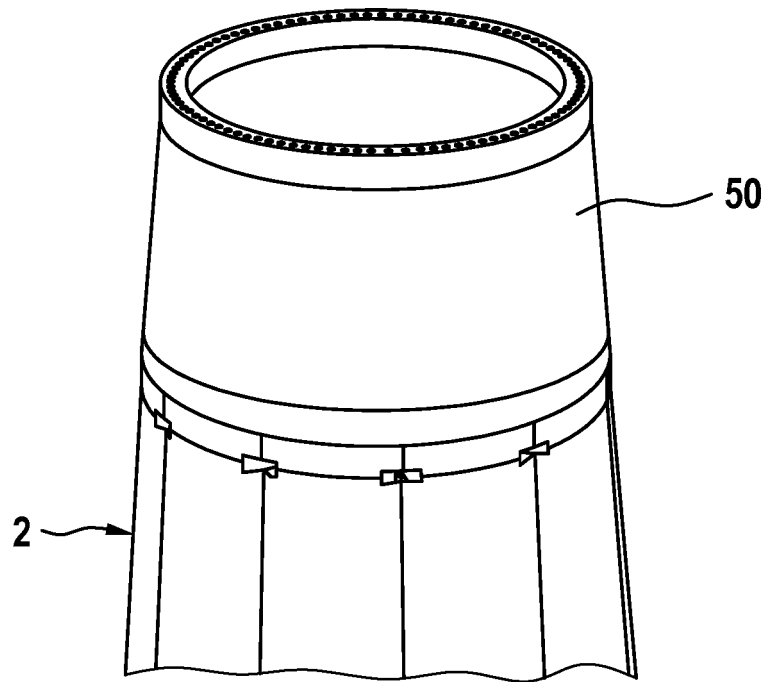

Fig. 2a

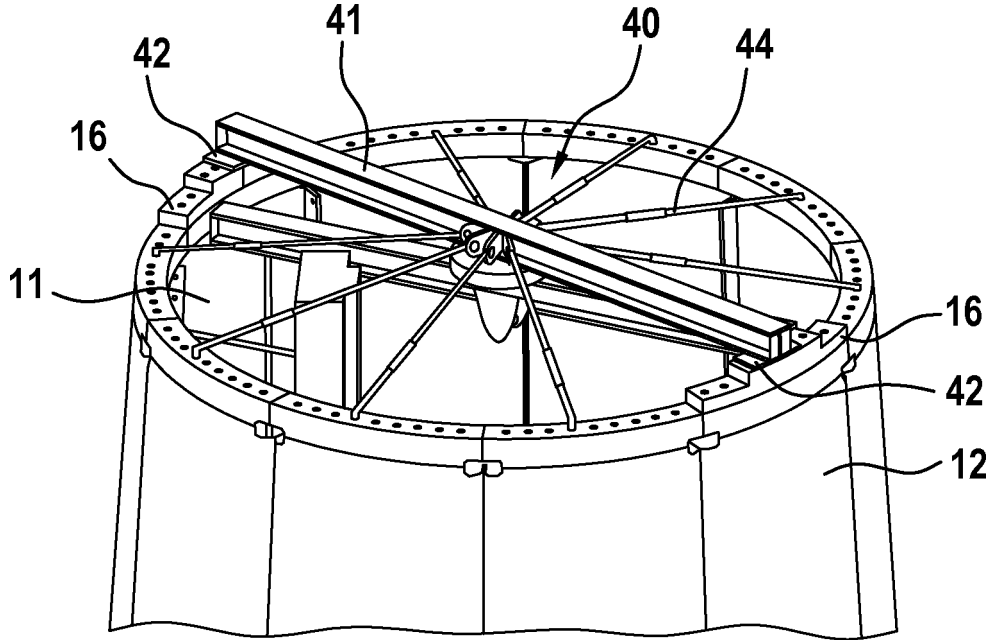

Fig. 2b

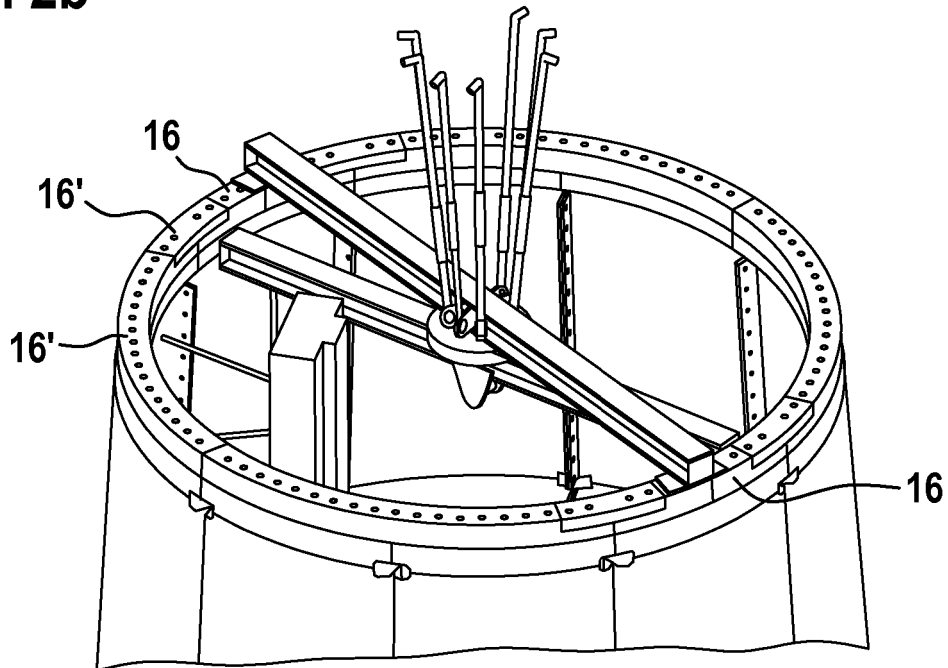

Fig. 3a

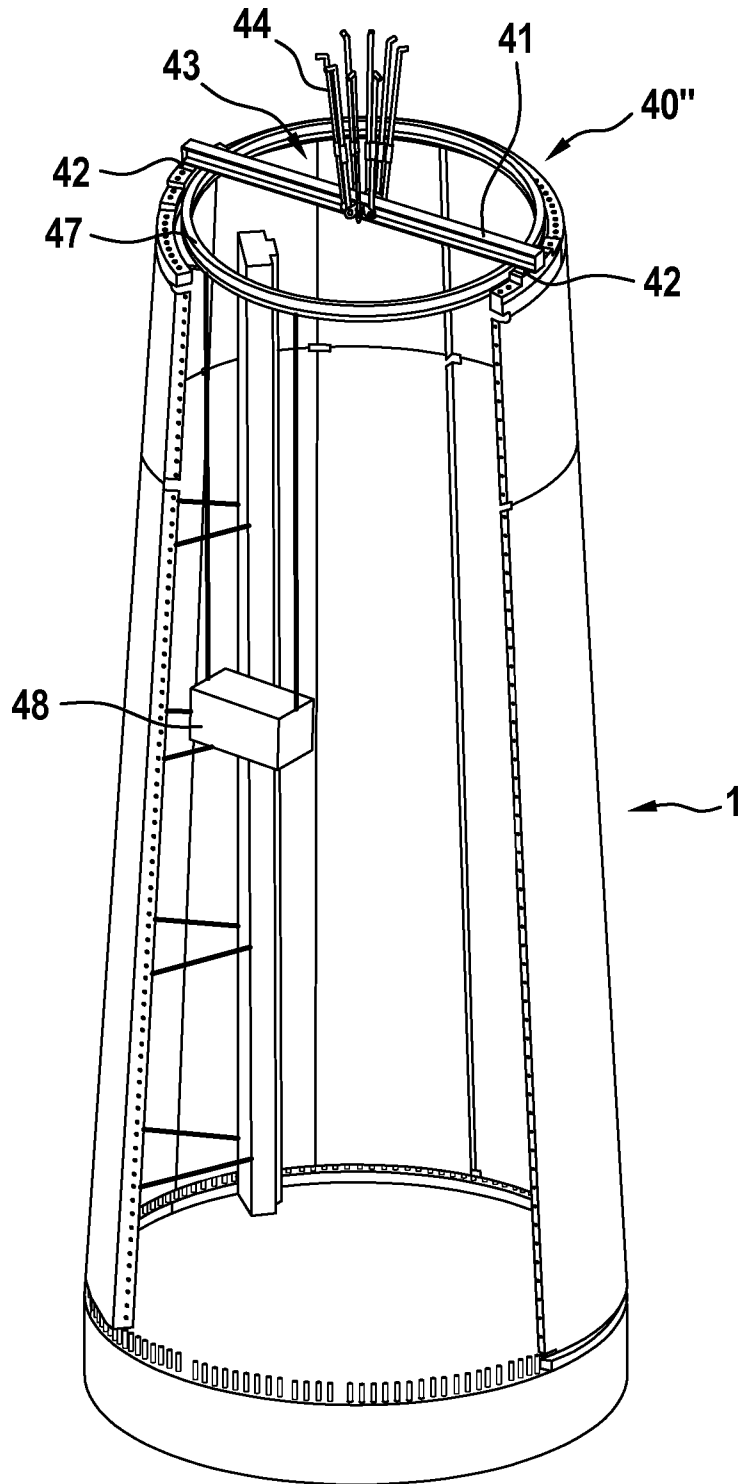

Fig. 3b

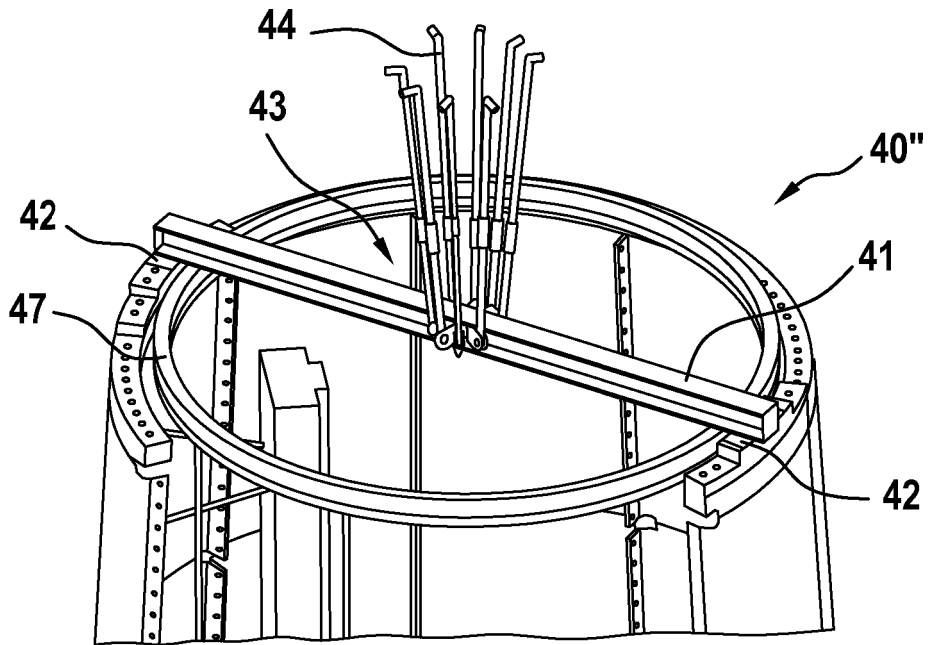

Fig. 4a

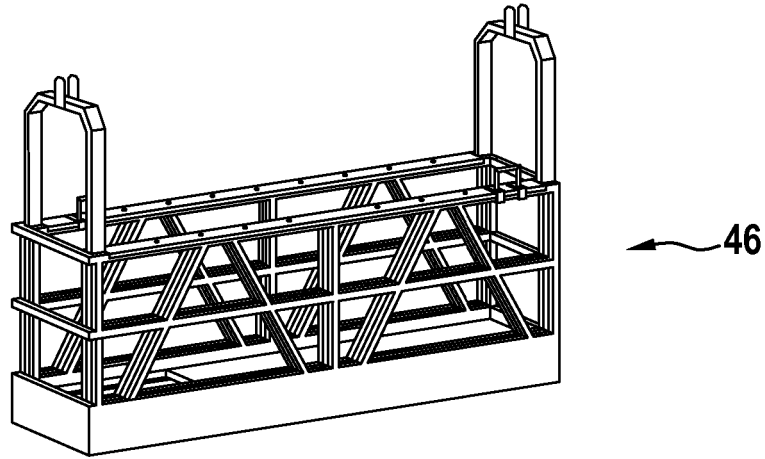

Fig. 4b

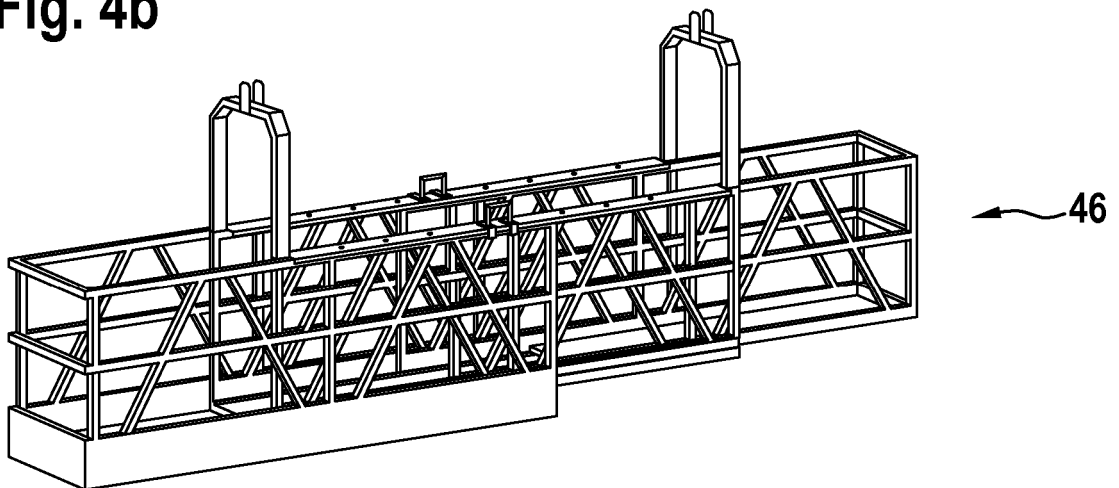

Fig. 4c

