

P. ROBERTS.

Improvement in Propelling and Steering Canal-Boats.  
No. 128,069.

Patented June 18, 1872.

Fig. 1.

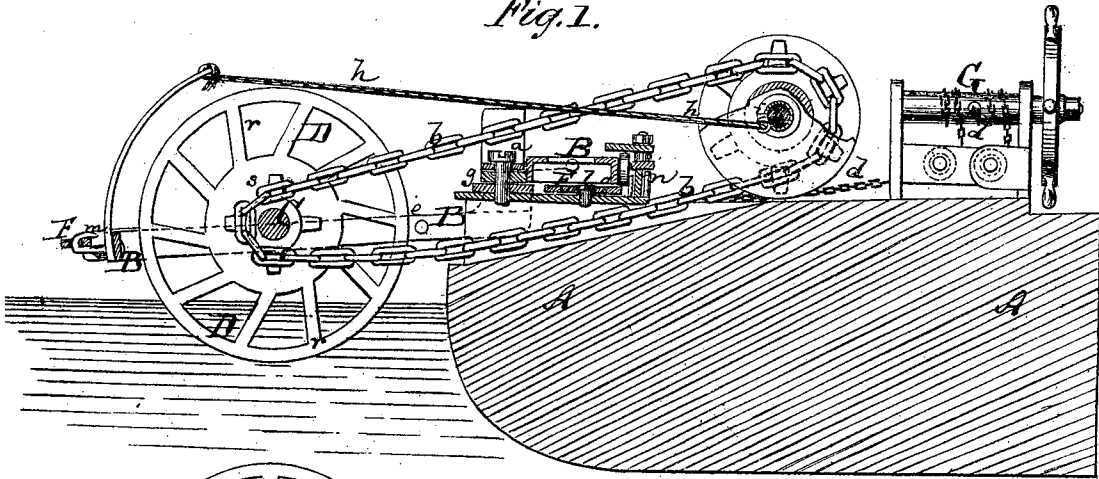

Fig. 3.

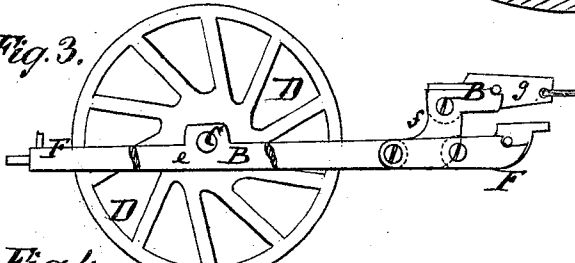

Fig. 5.

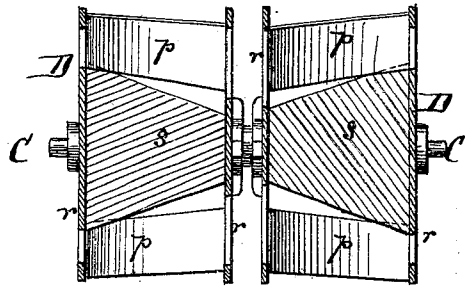

Fig. 4.

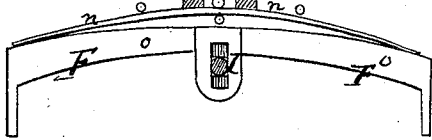
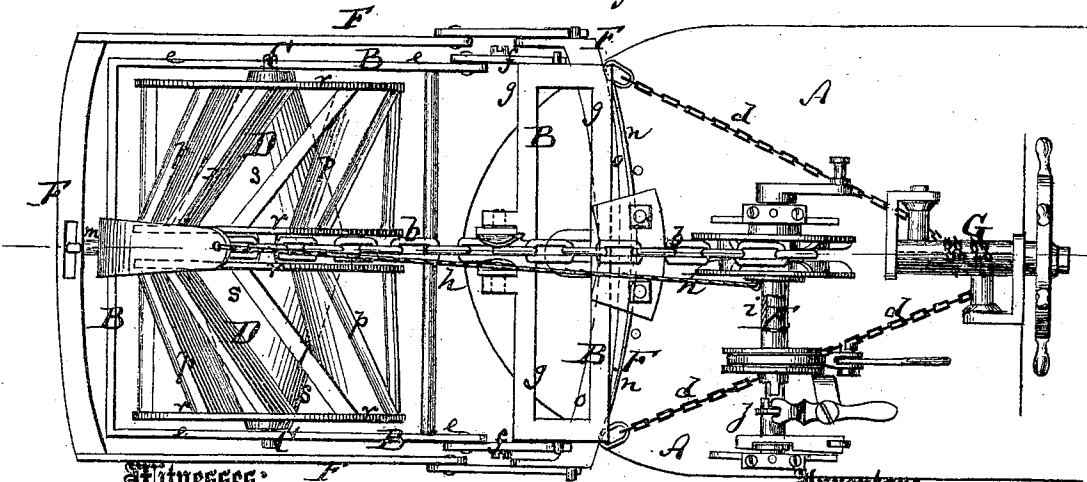

Fig. 2.



Witnesses:

John Becker,  
Alex. F. Roberts

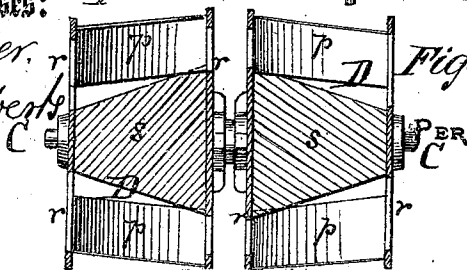

Fig. 6.

Inventor:

P. Roberts  
Munn & Co.  
Attorneys.

# UNITED STATES PATENT OFFICE.

PETER ROBERTS, OF NEW YORK, N. Y., ASSIGNOR TO HIMSELF AND WILLIAM A. REES, OF SAME PLACE.

## IMPROVEMENT IN PROPELLING AND STEERING CANAL-BOATS.

Specification forming part of Letters Patent No. 128,069, dated June 18, 1872.

Specification describing a new and useful Improvement in Propelling and Steering Mechanism for Canal-Boats, invented by PETER ROBERTS, of the city, county, and State of New York.

Figure 1 represents a vertical longitudinal section of my invention. Fig. 2 is a top view of the same. Fig. 3 is a detail side view of the propeller-frame, and Fig. 4 a detail top view of part of the same. Figs. 5 and 6 are vertical transverse sections through the double paddle-wheels, showing them in reversed relation to each other.

Similar letters of reference indicate corresponding parts.

This invention relates to a new paddle-wheel mechanism to be applied to canal-boats and other vessels for the purpose of propelling and steering the same. The invention consists, first, in a peculiar construction of paddle-wheel; and, secondly, in a spring-frame, which takes the shock of obstructions and protects the frame in which the wheel is journaled.

A in the drawing represents part of a canal-boat, being either the bow or stern part of the same. Directly at the end is pivoted to the boat, by a strong vertical bolt, *a*, a frame, B, in the sides of which the paddle-wheel shaft C has its bearings. D D are two parts of a double paddle-wheel mounted upon the shaft C. They receive rotary motion by a chain, *b*, or other connection from the driving-shaft E of a suitable engine fitted within or upon the boat. The sides of the frame B are, by ropes or chains *d d*, further connected with a steering-drum, G, by the turning of which, one rope *d* being wound up or shortened and the other unwound or lengthened, the frame B is swung to one side or the other to steer the vessel by means of its paddle-wheels. The sides *e e* of the frame B are directly or by means of intermediate links *f f* jointed to the cross-piece *g* of said frame, which is directly connected to the boat. These joints enable the frame B, together with the paddle-wheel, to be swung up or down, and to be, if desired, entirely carried out of the water. To enable such adjustment a rope or chain, *h*, extends from the outer end of the frame B to

a drum, *i*, on the driving-shaft E, or to any other part of the operating engine, said drum being thrown in gear, when required, to wind up the rope *h* by means of an adjustable clutch, *j*. F is a frame pivoted, at *l*, to the boat, and extending outward from it so as to embrace the frame B. It is, at the outer end, connected with said frame B, as at *m* in the drawing, and is jointed in line with the joints in the sides of B, so that it will swing up, together with B, whenever the paddle-wheel is lifted out of the water. Springs *n* bear against the pivoted cross-piece *o* of the frame F to right it whenever the paddle-wheel is directly in line with the axis of the boat, though they allow the frame F to swing sidewise when the paddle-wheel is moved for steering. The object of this frame F is to protect frame B and relieve it from any shocks or injury by contact with obstructions or other things. Each part of paddle-wheel consists of a series of oblique buckets or paddles, *p p*, set between rims *r r*, that project from a hub, *s*. The inner edges of the paddles *p*, though in contact with the larger part of the hub, are not so at and toward the smaller end of the same, leaving openings for the convenient escape of the water. The rims *r r* are also perforated for the escape of the water.

By means of the conical hub the discharge of water from the paddle-wheel is directed almost entirely to one side—that on which the hub is smallest.

The two parts of wheel on the same shaft may be placed with the small ends of the hub together, as in Fig. 5, in which case the water will be discharged in the middle; or they may, as in Fig. 6, be placed with their large ends together to discharge at the sides. The form shown in Fig. 5 appears more advantageous for canal-boats, as it prevents side swell. It may in many cases be desirable to reverse the position of the paddle-wheel on the same shaft to reverse the motion and to transplace the whole apparatus from the stern of the boat to the bow, or vice versa.

Having thus described my invention, I claim as new and desire to secure by Letters Patent—

1. A paddle-wheel, D D, consisting of a dou-

ble-cone hub, S S, and two sets of paddles, *p p*, arranged at an angle to one another, and with a space between said paddles and hub, as and for the purpose described.

2. A frame, B, which holds the paddle-wheel journaled therein, combined with the surrounding frame F, provided with a spring, *n*, resting against its cross-piece *o*, as described, so as to

protect frame B and receive, with a yielding resistance, the impact of any obstruction or shock.

PETER ROBERTS.

Witnesses:

T. B. MOSHER,  
GEO. W. MABEE.