

(19) **DANMARK**

(10) **DK/EP 3589987 T3**



(12) **Oversættelse af
europæisk patentskrift**

Patent- og
Varemærkestyrelsen

-
- (51) Int.Cl.: **G 01 V 5/12 (2006.01)**
- (45) Oversættelsen bekendtgjort den: **2023-08-07**
- (80) Dato for Den Europæiske Patentmyndigheds bekendtgørelse om meddelelse af patentet: **2023-05-10**
- (86) Europæisk ansøgning nr.: **18708830.7**
- (86) Europæisk indleveringsdag: **2018-02-21**
- (87) Den europæiske ansøgnings publiceringsdag: **2020-01-08**
- (86) International ansøgning nr.: **US2018018915**
- (87) Internationalt publikationsnr.: **WO2018160404**
- (30) Prioritet: **2017-02-28 US 201762464426 P** **2018-01-08 US 201862614810 P**
- (84) Designerede stater: **AL AT BE BG CH CY CZ DE DK EE ES FI FR GB GR HR HU IE IS IT LI LT LU LV MC MK MT NL NO PL PT RO RS SE SI SK SM TR**
- (73) Patenthaver: **Teague, Philip, 27822 Quiet Sky Place Dr, Spring, TX 77386, USA**
Sloan, Robert, 1002 Cutter Lane, Park City, UT 84098, USA
- (72) Opfinder: **Sloan, Robert, 1002 Cutter Lane, Park City, UT 84098, USA**
Teague, Philip, 27822 Quiet Sky Place Dr, Spring, TX 77386, USA
- (74) Fuldmægtig i Danmark: **Novagraaf Brevets, Bâtiment O2, 2 rue Sarah Bernhardt CS90017, F-92665 Asnières-sur-Seine cedex, Frankrig**
- (54) Benævnelse: **MÅLING AF IKKE-INVADERET DANNELSESDENSITET OG FOTOELEKTRISK EVALUERING MED EN RØNTGENKILDE**
- (56) Fremdragne publikationer:
EP-A1- 0 860 715
EP-A1- 2 275 840
WO-A1-2008/032265
WO-A2-2012/058579
GB-A- 2 444 801

DESCRIPTION

Field of the Invention

[0001] The present invention relates generally to means for formation density and photoelectric evaluation, and in a particular embodiment to means of non-invaded formation density measurement and photoelectric evaluation using an x-ray source.

Background

[0002] Well or borehole logging is the practice of making an accurate record, known as a well log, of the geologic formations through which a borehole creates a path or conduit. Well logging activities are performed during all phases of an oil and gas well's development; drilling and evaluation, completion, production and abandonment.

[0003] The oil and gas industry logs rock and fluid properties to find hydrocarbon-bearing strata in the formations intersected by a borehole. The logging procedure consists of lowering a tool on the end of a wireline into the well to measure the properties of the formation. An interpretation of these measurements is then made to locate and quantify potential zones containing hydrocarbons and at which depths these zones exist.

[0004] Logging is usually performed as the logging tools are pulled out of the hole. This data is recorded in real-time via a data connection to the surface logging unit or using a memory unit aboard the tool to create either a printed record or electronic presentation called a well log which is then provided to the client. Well logging is performed at various intervals during the drilling of the well and when the total depth is drilled.

[0005] Density logging is the practice of using a specific well logging tool to determine the bulk density of the formation along the length of a wellbore. The bulk density is the overall density of a rock including the density of the minerals forming the rock and the fluid enclosed in the pores within the rock.

[0006] A radioactive isotope-based source, usually Cesium 137 (^{137}Cs), applied to the wall of the borehole emits gamma rays into the formation so these gamma rays may be thought of as high velocity particles which collide with the electrons of the atoms that compose the formation. At each collision the gamma rays lose energy to the electrons, and then continue with diminished energy. This type of interaction is known as Compton scattering. A proportion of the scattered gamma rays reach detectors, located at fixed distances from the source, and is counted as an indication of formation density.

[0007] The number of Compton scattering collisions is related directly to the number of the

electrons per unit volume, or electron density, within the formation. Consequently, the electron density determines the response of the density tool.

[0008] Wellbore logging operations within the oil and gas industry currently use radioactive isotopes for the purpose of a ready supply of gamma rays which are used in the evaluation of the geological formations surrounding a borehole.

[0009] The use of radioactive isotopes within oilfield operations such as the production, logistics, handling, operational use and disposal of such sources is controlled by regulation. The transport of such isotopes across geographical and political borders is heavily regulated and controlled, due to the risk associated with the potential to cause harm to humans, either accidentally or intentionally, through the direct dispersal of the radioactive materials across a populated region or indirectly via introduction into the food chain.

[0010] However, the use of such isotopes is tolerated as there has been no viable replacement for the technology until recently. The ability to replace radioactive isotopes with devices and methods which do not utilize radioactive materials boasts a number of key advantages when considering all aspects of the operational cycle of a wellbore log, from commercial to health, safety and the environment.

[0011] The use of ^{137}Cs within oilfield operations is controlled through governmental regulation, export treaties and embargoes. Generally, such isotopes are produced in a nuclear reactor in the country in which they are intended to be used. The transport of such isotopes across geographical and political borders is heavily regulated and controlled, due to the risk associated with the potential to cause harm to humans, either accidentally or intentionally, through the direct dispersal of the radioactive materials across a populated region or indirectly via introduction into the food chain.

[0012] After entering the body, ^{137}Cs is generally uniformly distributed throughout the body, with higher concentrations manifesting in muscle tissues and lower concentrations in bones. The biological half-life of ^{137}Cs is about 70 days. Experiments on canines showed that a single dose of 0.0038 Curie per kilogram is lethal within three weeks. Density logging operations in oilfield typically use 1.1 Curie of ^{137}Cs which equates of a small volume of material weighing 0.012 grams.

[0013] The improper handling of ^{137}Cs gamma ray sources can lead to release of the radioisotope and consequent radiation injuries. Cesium gamma ray sources that have been encased in metallic housings can be mixed in with scrap metal on its way to smelters, resulting in production of steel contaminated with radioactivity.

[0014] In oilfield operations, isotopes can be lost into the well as a result of the breakage of the logging tool at the risk of being irretrievable. Such events can lead to the closure of the well or measures taken to ensure that radioactive material cannot circulate or permeate out of the

well. Indeed, direct contamination and the risk to oilfield workers of dangerous levels of exposure are not uncommon. Although comprehensive control measures are in place, the risk associated with the use of highly radioactive isotopes during oilfield operations will always be present-unless a viable isotope-free option can be introduced.

[0015] As is the nature of radioactive materials, the half-life of the material also determines its useful lifetime. Although density logging tools are calibrated to take into account the reduction in activity of an isotope, the useful life of the isotope is somewhat short-lived. A ^{137}Cs source will be producing only half of its initial gamma ray output after a period of 30 years. A consequence is that isotope-based sources need to be replaced at intervals, and the older isotopes disposed of. The disposal requirements must take similar precautions to that of normal nuclear waste, such as that produced as a waste product at nuclear power stations.

[0016] However, none of the prior art teaches of the ability to increase the axial offset of the density detectors for the purpose of avoiding the mud-invaded zone, thereby increasing the accuracy of the litho-density measurement and lessening the impact of mud-weight and formation porosity on the litho-density measurement.

[0017] For example, US 7,675,029 B2 teaches the use of an x-ray device to create a two-dimensional image of a target object in a borehole using backscattered radiation from an x-ray source by means of a collimated detector, but fails to disclose a method of using the increased output of the x-ray device to enable longer offset detectors to enable analysis of the non-invaded zone of the formation. Methods to increase the permissible count rate within a detector volume by doubling the number of PMTs for a given detector volume and the use of an x-ray source to measure the photoelectric properties of a formation directly are also not disclosed.

[0018] US 7,564,948 B2 discloses an x-ray source being used as a replacement for a chemical source during density logging along with various means of arranging the apparatus and associated power supply, and also discloses a means of filtering the primary beam from the x-ray source such that a filtered dual-peak spectrum can be detected by a reference detector used to directly control (feedback) the x-ray tube voltage and current for stability purposes. However, the reference only teaches a compact x-ray device (bipolar) with a grid, a power supply which is a Cockcroft-Walton rolled up into a cylinder (between two Teflon cylinders) to save space, and the aforementioned filtered reference detector method. Methods and means of using the increased output of the x-ray device to enable longer offset detectors to enable analysis of the non-invaded zone of the formation, increasing the permissible count rate within a detector volume by doubling the number of PMTs for a given detector volume, and the use of an x-ray source to measure the photoelectric properties of a formation directly are also not disclosed.

[0019] US 8,481,919 B2 teaches a means of creating and controlling the electrical power necessary, by serially stepping up the DC reference and creating high potential field control surfaces, to control either a bipolar or unipolar x-ray tube for the purposes of replacing

chemical sources in reservoir logging. The reference also teaches moveable / manipulable beam hardening filters and rotating light-house collimation on the source, and the use of gaseous insulators including SF₆ as an electrical insulator in a downhole x-ray generator. However, the reference fails to disclose a method of using the increased output of the x-ray device to enable longer offset detectors to enable analysis of the non-invaded zone of the formation. The reference also fails to disclose a method of increasing the permissible count rate within a detector volume by doubling the number of PMTs for a given detector volume as well as the use of an x-ray source to measure the photoelectric properties of a formation directly. GB 2 444 801 A relates to an apparatus and method for evaluating a formation surrounding a borehole using an x-ray generator. EP 0 860 715 A1 relates to the determination of an earth formation density and lithology of an earth formation. WO 2012/058579 A2 discloses an In-Situ Downhole X-Ray Core Analysis System. EP 2 275 840 A1 describes an apparatus and methods for measuring properties of formations surrounding a borehole. WO 2008/032265 A1 discloses an apparatus and a method for evaluating fluids encountered in a well services context using x-rays.

Summary

[0020] The invention relates to an x-ray based litho-density tool for measurement of simultaneous invaded and non-invaded formation surrounding a borehole according to claim 1.

Brief Description of the Drawings

[0021]

Figure 1 illustrates an x-ray based litho-density formation evaluation tool deployed by a wireline conveyance into a borehole, wherein the formation density is measured by the tool.

Figure 2 is a layout view of a practical means of exercising the method within the confines of a borehole tool configured to measure formation density, non-invaded bulk density and borehole corrections using an x-ray tube as a radiation source.

Figure 3 illustrates a typical reference detector spectrum for a Compton range source, showing Intensity in the y-axis versus photon energy in the x-axis, wherein the windowed region of interest (the region between two specified energies) remains unchanged as the spectrum peak intensity moves.

Figure 4 illustrates a typical x-ray based plot of Density (DRho) vs RhoLS - RhoSS, noting the slope of Aluminum [403] versus Magnesium [404] responses, consistent with those typically by associated with a ¹³⁷Cs based litho-density tool.

Figure 5 illustrates a typical x-ray based plot of PE response, indicating a "Short Space" detector capable of predictable behavior when considering the photoelectric response of

Magnesium, aluminum, and a Sleeve of known PE (in this case stainless steel).

Figure 6 illustrates a comparison of the spectral form of detected energies at the bulk density detector when measuring an aluminum formation versus a magnesium formation, when using ^{137}Cs and X-rays.

Figure 7 illustrates a spectral representation of the short space detector showing intensity versus photon energy; the short space detector can be used to collect a spectrum of incoming photons, or to collect based upon energy thresholds, wherein specific energy windows are used to separate between counts originating from Compton scattering events, and those originating from photoelectric.

Figure 8 illustrates the Aluminum-Magnesium slope on a DRho vs RhoLS-RhoSS plot exhibits 'ribs' that are the result of calibrating against mud-cake mats of varying mud-weights.

Brief Description of Several Example Embodiments

[0022] The invention described herein consists of an apparatus using an electronic x-ray device as a replacement for a chemical gamma ray source when attempting to achieve a density computation to determine the density of a formation within an oil and gas well. The invention further teaches of a means of improving upon the accuracy of the measurement by using the significantly higher output of an x-ray source (compared to 1.5Ci of ^{137}Cs) to increase the axial offset of a bulk-density detector, while maintaining the statistical requirements necessary to achieve 0.01g/cc repeatability, thereby permitting a depth of investigation that is outside of the mud-invaded zone of the formation within the oil and gas well. This method provides a way to add data to the litho-density measurement and provides a method to remove uncertainty regarding mud-weight dependencies.

[0023] The invention consists of known and new technologies combined in a new application with respect to radiation physics and formation evaluation measurements for use within the oil and gas industry. The method is further embodied by a means, which may be used to practice the method for use in a water, oil or gas well.

[0024] The typical regulatory limit for the amount of ^{137}Cs which may be used during a logging operation is a maximum of 1.3 Curie. During density logging operations, a certain number of photons per second are required to enter into the detectors to ensure a high enough statistic for the purposes of data quality consistency and interpretation. As a result, density logging operations are normally performed such that the tool is moved at a rate of 1,800ft/hr to ensure sufficient photons enter the detectors at any particular depth to offer a data resolution acceptable to the client (typically a repeatability to 0.01g/cc density). In a 15,000ft long well, this can translate to just over 8 hours of logging time, bottom to surface (or at least 2 hours in

the zone of the reservoir).

[0025] The operations cannot currently be performed faster as the speed of logging relates to the acquisition speed that is proportional to the output of the gamma source. For safety reasons, the amount of ^{137}Cs which may be used is capped, with a resultant cap in the minimum amount of time required to perform a log.

[0026] There are currently no viable technologies that have the ability to increase the axial offset of the density detectors for the purpose of avoiding measurement of the mud-invaded zone, thereby increasing the accuracy of the litho-density measurement and lessening the impact of mud-weight and formation porosity on the litho-density measurement.

[0027] With reference now to the attached Figures, Figure 1 illustrates an x-ray based litho-density formation evaluation tool 101 is deployed by wireline conveyance 102, 103 into a borehole 104, wherein the formation 105 density is measured by the tool 101.

[0028] Figure 2 is a layout view of a practical means of exercising the method within the confines of a borehole tool 201 configured to measure formation density, non-invaded bulk density and borehole corrections using an x-ray tube 203 as a radiation 204 source. The x-ray source 203 produces a beam of x-rays 204 that illuminates the formation 202. The x-ray source output is monitored by a reference detector 205. No direct beam path through the shielding 209 that surrounds the source 203 and detectors 205, 206, 207, 208 is necessary as the reference detector uses the shielding 209 to attenuate the radiation emanating directly from the source 204. Note that the bulk density detector 207 is double-ended, such that the scintillator crystal is effectively comprised of two crystals back-to-back in the space of a single crystal (photomultiplier on each end). This arrangement effectively doubles the number of counts per second that can be collected prior to saturation while maintaining the detector volume.

[0029] Figure 3 illustrates a typical reference detector spectrum for a Compton range source, showing intensity in the y-axis 301 versus photon energy in the x-axis 302, the windowed region of interest 303 (the region between two specified energies) remains unchanged as the spectrum peak intensity 304 moves.

[0030] Figure 4 illustrates a typical x-ray based plot of Density (DRho) 401 vs RhoLS - RhoSS 402, note the slope of Aluminum 403 versus Magnesium 404 responses, being consummate with those typically by associated with a ^{137}Cs based litho-density tool.

[0031] Figure 5 illustrates a typical x-ray based plot of PE response, indicating that the short space detector is capable of predictable behavior when considering the photoelectric response of Magnesium 501, aluminum 502 and a Sleeve of known PE (in this case stainless steel) 503. See Figure 7 for further clarification of PE ratios.

[0032] Figure 6 illustrates a comparison of the spectral form of detected energies at the bulk

density detector when measuring an aluminum formation versus a magnesium formation, when using ^{137}Cs and X-ray. The x-ray equivalent 603 in aluminum of a ^{137}Cs measurement 604 is of a very similar form. Equally, the x-ray equivalent 601 in magnesium of a ^{137}Cs measurement 602 is also of a very similar form. The formation tends to filter/scatter the higher energy of the ^{137}Cs to such a degree that the form of the spectrum is practically indistinguishable from X-ray. As such the x-ray measurement physics result is interchangeable with that of a standard ^{137}Cs -based litho-density tool.

[0033] Figure 7 is a spectral representation of the short-space detector showing intensity 701 versus photon energy 702. The short space detector can be used to collect a spectrum of incoming photons, or to collect based upon energy thresholds, wherein specific energy windows are used to separate between counts originating from Compton scattering events, and those originating from photoelectric. In this respect, photoelectric energies would be represented by the counts within Window 1 703, and Compton within Window 2 704. The ratio of the counts collected within Window 1 to Window 2 gives the basis of the photoelectric measurement.

[0034] Figure 8 illustrates the Aluminum-Magnesium slope 803 on a DRho 801 vs RhoLS-RhoSS 802 plot exhibits ribs 804, 805, 806, 807 that are the result of calibrating against mud-cake mats of varying mud-weights. Each curve 804, 805, 806, 807 is comprised of points that represent carrying thicknesses of mud-cake. In a typical Cs-based litho-density log, the mud-weight needs to be known to understand which rib the tool response is operating on.

[0035] In one example embodiment, the x-ray based litho-density formation evaluation tool 101 is deployed by wireline conveyance 102,103 into a borehole 104, wherein the formation 105 density is measured by the tool 101. The tool 101 is enclosed by a pressure housing 201 which ensures that well fluids are maintained outside of the housing. The tool 101 is configured to measure formation density, non-invaded bulk density and borehole corrections using an x-ray tube 203 as a radiation 204 source.

[0036] The x-ray source 203 produces a beam of x-rays 204 that illuminates the formation 202. The x-ray source output is monitored by a reference detector 205. No direct beam path through the shielding 209 that surrounds the source 203 and detectors 205, 206, 207, 208 is necessary as the reference detector uses the shielding 209 to attenuate the radiation emanating directly from the source 204. Note that the bulk density detector 207 is double-ended, such that the scintillator crystal is effectively comprised of two crystals back-to-back in the space of a single crystal (photomultiplier on each end). This arrangement effectively doubles the number of counts per second that can be collected prior to saturation of the crystal while maintaining the detector volume.

[0037] In an example not forming part of the presently claimed invention, the detector crystal may be made from a direct conversion type, which converts the incoming x-ray photons directly into cascading electrons, to be read by an electronic read-out device, rather than the x-

rays being converted/scintillated to visible light within the crystal, which then must be converted to an electronic pulse via use of a photomultiplier tube.

[0038] In a still further example not forming part of the presently claimed invention, the crystal volume may be replaced entirely by an arrayed imaging detector, such as a Cadmium Telluride or Cadmium Zinc Telluride detector that is bonded to a two dimensional array of read-out circuits within an Application Specific Integrated Circuit (ASIC).

[0039] In a further embodiment still, at least two detectors 206, 207, 208 made of a scintillator crystal with an embedded micro-isotope check source (to be used in detector gain stabilization), are located axially offset from an x-ray tube 204 within a pressure housing 201. The pressure housing 201 is maintained against the wall of a borehole by means of a wear-pad 210. The tool is conveyed by means of a wireline or other conveyance device, along the axis of the well, typically filled with drilling fluids, such as mud. As a result of the drilling activity that created the well, mud (or drilling fluids) penetrate into the formation 202 a short distance leaving a mud-cake where the particulates within the mud get filtered out of the drilling fluid that permeates the formation.

[0040] In yet another embodiment, the detector 206 closest to the output beam exit (of the x-ray source) is primarily used to measure the standoff between the tool and the formation, due to borehole rugosity, and therefore, how much well fluid is between the tool and the formation (detector known as the short space). This is important as the amount of source radiation leaking down the annular space 211 between the tool and the formation gives rise to an increase in the number of photons entering the detectors 206, 207, 208 that have not been through the formation 202 (also known as borehole effect). In addition, the detector 206 can be used to measure photoelectric effects and give an indication of the type of materials forming the formation make-up. The short space detector can be used to collect a spectrum of incoming photons, or to collect based upon energy thresholds, wherein specific energy windows are used to separate between counts originating from Compton scattering events, and those originating from photoelectric.

[0041] In this respect, photoelectric energies would be represented by the counts within Window 1 703, and Compton within Window 2 704. The ratio of the counts collected within Window 1 to Window 2 gives the basis of the photoelectric measurement. This is achieved through comparing two energy windows within the collected energy spectrum of the detector, one set at a lower energy (such as 80-100keV) and another set at Compton energy ranges (such as 110-600keV). Comparison of the ratio of the counts collected in each energy window permits an index of photoelectric effect, which may be characterized based upon the types of materials anticipated in the formation. The photoelectric index can be presented as a measurement versus depth of log.

[0042] In another embodiment, the next detector 207 further offset (known as the bulk density detector or long space) from the output beam 204 exit is used to measure formation 202 density. The output of this detector is compensated for borehole effect by measuring the

known response of said detector to the characteristics of the short space detector. This detector is used to measure bulk density, which can be computed from the effective electron density of the formation. This is calculated from the known output of the x-ray source 204. The higher the density of the formation 202, the fewer the number of counts enter the long space; conversely, the lower the formation density, the higher the number of counts. As the number of counts that can enter the bulk density detector 207 is so large compared to that of a typical ^{137}Cs -based tool, either a scintillator with a lower conversion and restoration time needs to be selected (such as LaBr), or higher market availability scintillators, such as NaI, can be used with an innovation. In the invention, the bulk density detector 207 is double-ended, such that the scintillator crystal is effectively comprised of two crystals back-to-back in the space of a single crystal (photomultiplier on each end). This arrangement effectively doubles the number of counts per second that can be collected prior to the saturation of the crystal while maintaining the detector volume within a specific region of source 204 to detector 207 axial offset.

[0043] Due to the large output of the x-ray device, there are sufficient photons to ensure that a large number of photons can be detected at a significantly larger offset than typical ^{137}Cs tools. For example, around 1,500 counts per second are required to be collected in the bulk density detector 207 in the region 180keV to 510keV to be able to compute a density with an uncertainty of 0.01g/cc at a logging speed of 1,800 ft/hr. With an x-ray tube that is configured at a voltage sufficient to produce Compton scattering in the formation (i.e. >200keV), then >1,500 counts per second of detected photons in bulk density detector 207 can be achieved at much higher logging speeds. An alternative use of the greater statistics is to adopt an additional detector at a much larger offset than typical long space detectors, and still have sufficient statistics (even with the larger offset) to achieve 0.01g/cc. Typically, the number of counts at a certain position falls off exponentially with the axial offset distance from the source 204 beam exit.

[0044] One benefit of placing an additional detector at a much larger axial offset is that its depth of investigation is larger than a typical long space detector. Such a detector would be capable of measuring litho-density within the non-invaded zone of the formation, such that the effect of mud-cake could be eliminated.

[0045] In a further embodiment, an additional detector 208 further offset (known as the non-invaded bulk density detector or ultra-long space) from the output beam 204 exit is used to measure formation 202 density. The output of this detector is compensated for borehole effect by measuring the known response of said detector to the characteristics of the short space detector 206. The non-invaded bulk density detector 208 is used to measure the bulk density of the non-invaded portion of the formation 202 that has not been directly affected by drilling fluid invasion, hence can be computed from the effective electron density of the formation. In a further embodiment, the output of this detector is compensated for borehole effect by measuring the known response of said detector to the characteristics of the short space detector 206 and by that of the bulk density detector 207.

[0046] In a further embodiment, the Aluminum-Magnesium slope 803 on a DRho 801 vs RhoLS-RhoSS 802 plot exhibits ribs 804, 805, 806, 807 that are the result of calibrating against mud-cake mats of varying mud-weights. Each curve 804, 805, 806, 807 is comprised of points that represent carrying thicknesses of mud-cake. In a typical Cs-based litho-density log, the mud-weight needs to be known to understand which rib the tool response is operating on. Consequently, in the standard spine-rib algorithm all the ribs for the different mud-weights are collapsed onto a single rib. In addition, mud-mat/standoff thicknesses greater than 0.75" typically result in a curvature that detaches from the single rib, making it difficult to determine which rib is relevant for the log. However, by modulating the output energy of the x-ray source 204, it would be possible to determine the mud-cake type which would mean that the specific rib for that mud-weight could be used (rather than a generic rib), allowing any offset corrections/compensation greater than 0.75" to function correctly.

[0047] In a further embodiment still, the tool 101 is located within a logging-while-drilling (LWD) string, rather than conveyed by wireline. In a further embodiment, the LWD provisioned tool 101 would be powered by mud turbines.

[0048] In yet another embodiment, the tool 101 is combinable with other measurement tools such as neutron-porosity, natural gamma and/or array induction tools.

[0049] Providing a log showing the compensated long space computed density in addition to the compensated non-invaded ultra-long space computed density gives operators the ability to determine the veracity of their computed density and eliminate any concerns regarding the effect of mud invasion into the formation zone being measured.

[0050] Additionally, the higher intensity of the x-ray source can be used to perform very high speed (7,200ft/hr) logging runs without sacrificing the statistics necessary to produce no more than 0.01g/cc uncertainty within the measurement. As such, this would lead to the ability to perform the measurement at 4 times the speed of existing techniques and reduce the amount of rig time used to a quarter of that required for a typical ¹³⁷Cs-based logging run.

[0051] Furthermore, the removal of the need for the dangerous radioactive isotope ¹³⁷Cs with an x-ray source, which is harmless when de-energized, will revolutionize the simplicity and safety of the logistics and handling of logging equipment worldwide.

[0052] The foregoing specification is provided only for illustrative purposes, and is not intended to describe all possible aspects of the present invention. While the invention has herein been shown and described in detail with respect to several exemplary embodiments, those of ordinary skill in the art will appreciate that minor changes to the description, and various other modifications, omissions and additions may also be made without departing from the scope of the invention, which is solely defined by the appended claims.

REFERENCES CITED IN THE DESCRIPTION

Cited references

This list of references cited by the applicant is for the reader's convenience only. It does not form part of the European patent document. Even though great care has been taken in compiling the references, errors or omissions cannot be excluded and the EPO disclaims all liability in this regard.

Patent documents cited in the description

- [US7675029B2 \[0017\]](#)
- [US7564948B \[0018\]](#)
- [US8481919B \[0019\]](#)
- [GB2444801A \[0019\]](#)
- [EP0860715A1 \[0019\]](#)
- [WO2012058579A2 \[0019\]](#)
- [EP2275840A1 \[0019\]](#)
- [WO2008032265A1 \[0019\]](#)

PATENTKRAV

1. Et røntgenbaseret litografisk densitetsværktøj (101, 201) til sideløbende måling af invaderet og ikke-invaderet dannelse (105, 202) omkring et borehul (104), hvor værktøjet består af:

5 en indvendig længde bestående af et sondeafsnit, hvori det nævnte sondeafsnit består af en røntgenkilde (204,203), hvori værktøjet (101, 201) bruger røntgen (204) til at belyse dannelsen (105, 202) omkring et borehul (104); en pluralitet af detektorer til strålingsmåling (205, 206, 207, 208), som bruges til direkte at måle både invaderede og ikke-invaderede dannelsesdensiteter; mindst
10 én kildeovervågningsdetektor (205); og en pluralitet af sonde-afhængig elektronik,

der karakteriseres ved,

at den nævnte pluralitet af detektorer til strålingsmåling (205, 206, 207, 208) består af en densitetsdetektor (207), som består en scintillationskrystal og har to ender således, at scintillationskrystallen i praksis består af to krystaller med
15 bagsiden mod hinanden med en fotomultiplikator i hver ende.

2. Værktøjet (101, 201) i Krav 1, der yderligere omfatter en række værktøjslogisk elektronik og PSU'er.

3. Værktøjet (101, 201) i Krav 1, der yderligere omfatter en detektor til måling af borehulsplaceringsstift således, at andre detektorsvar udignes i forhold til
20 værktøjsplaceringsstift.

4. Værktøjet (101, 201) i Krav 1, der yderligere omfatter en lang pladsdetektor; en ultralang pladsdetektor; og en kilde (203) placeret inden i en kollimeret strålingsafskærmning (209).

5. Værktøjet (101, 201) i Krav 4, i hvilket den nævnte afskærmning (209) er,
25 yderligere omfatter tungsten.

6. Værktøjet (101, 201) i Krav 1, i hvilket det nævnte værktøj (101, 201) yderligere omfatter en slidpude, der er placeres således, at kilden (203) og

detektorsamlingen kan presses mod siden af borehullet (104) for at reducere borehulseffekter.

7. Værktøjet (101, 201) i Krav 1, hvori referencedetektoren (205) bruges til at overvåge outputtet af røntgenkilden (204, 203).

DRAWINGS

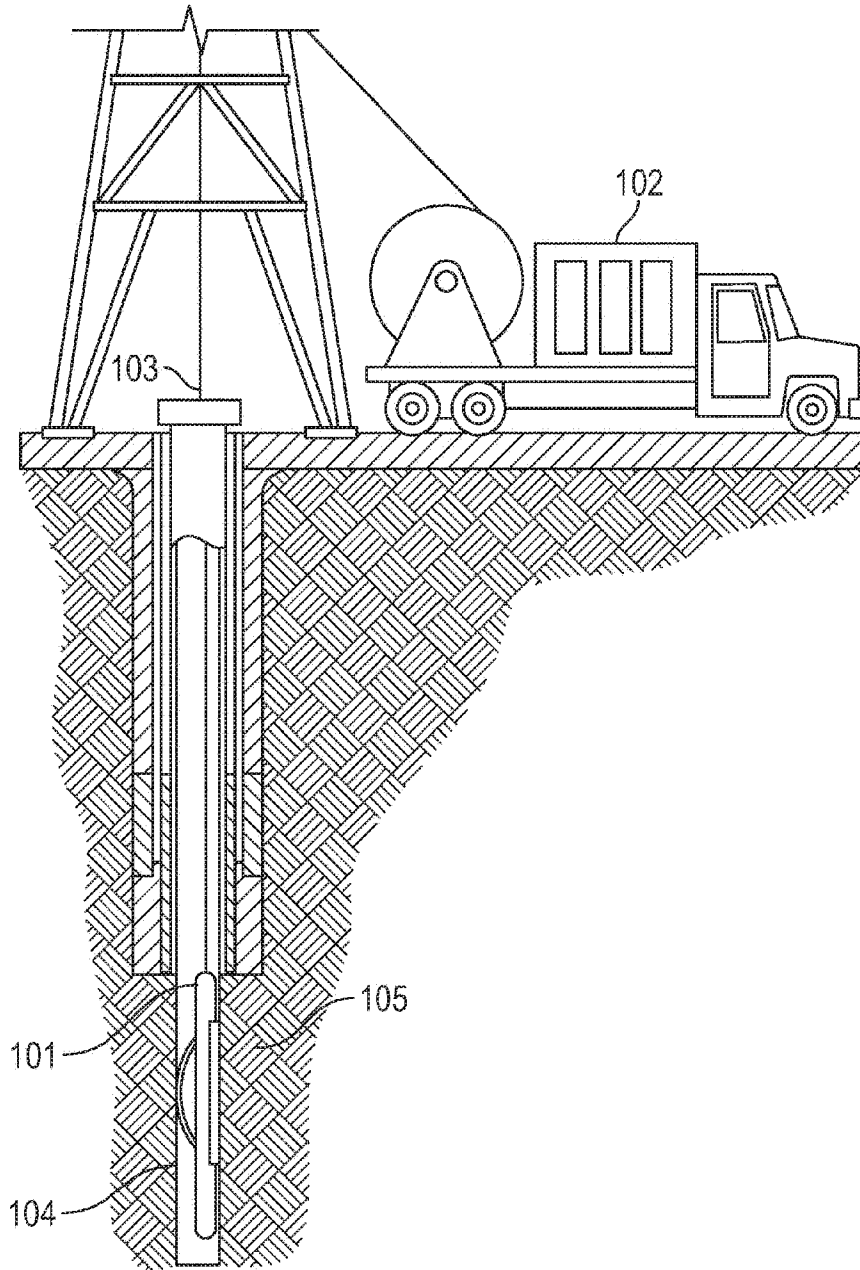

FIG. 1

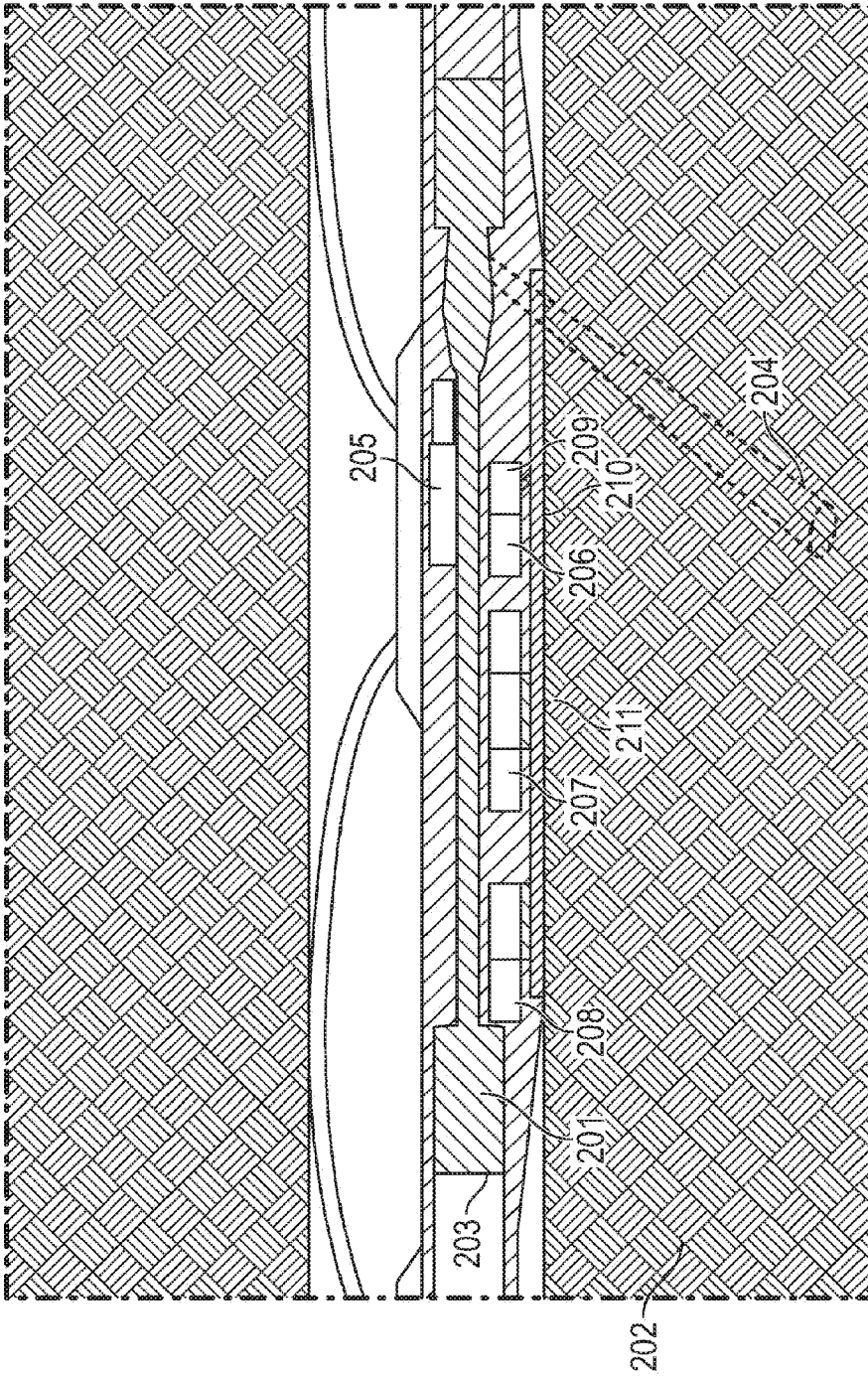

FIG. 2

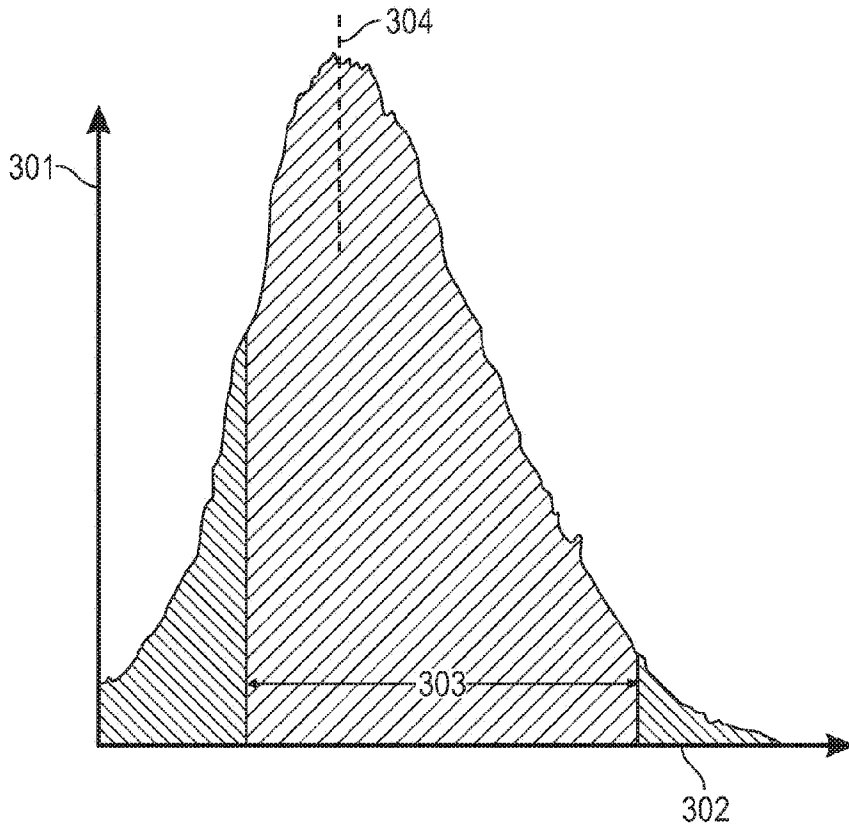

FIG. 3

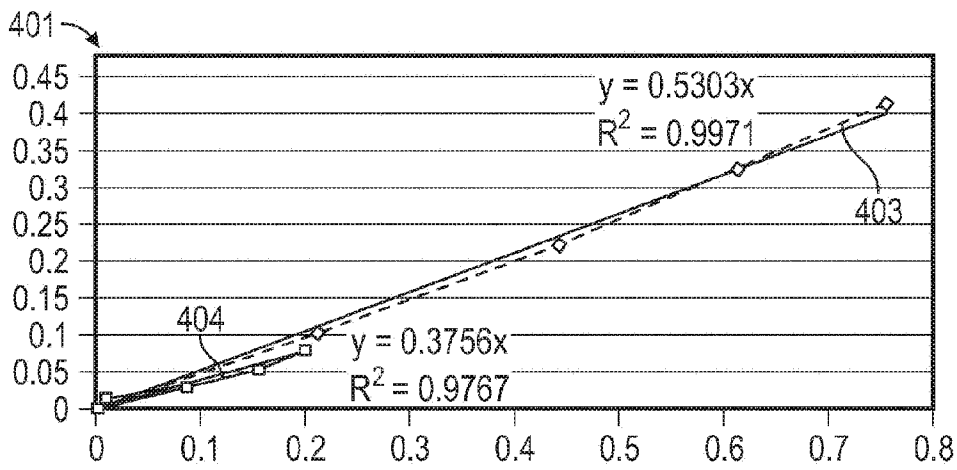

FIG. 4

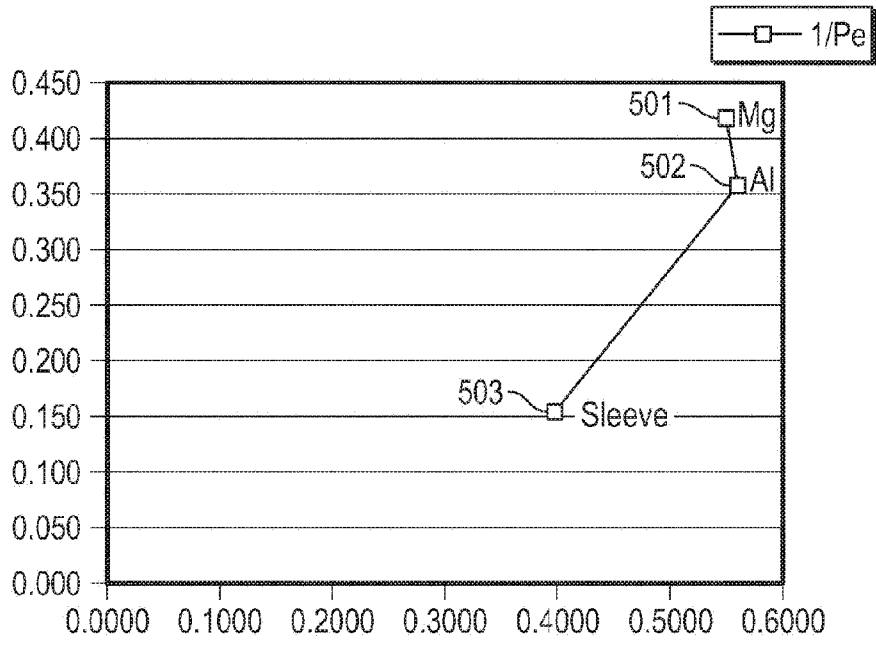

FIG. 5

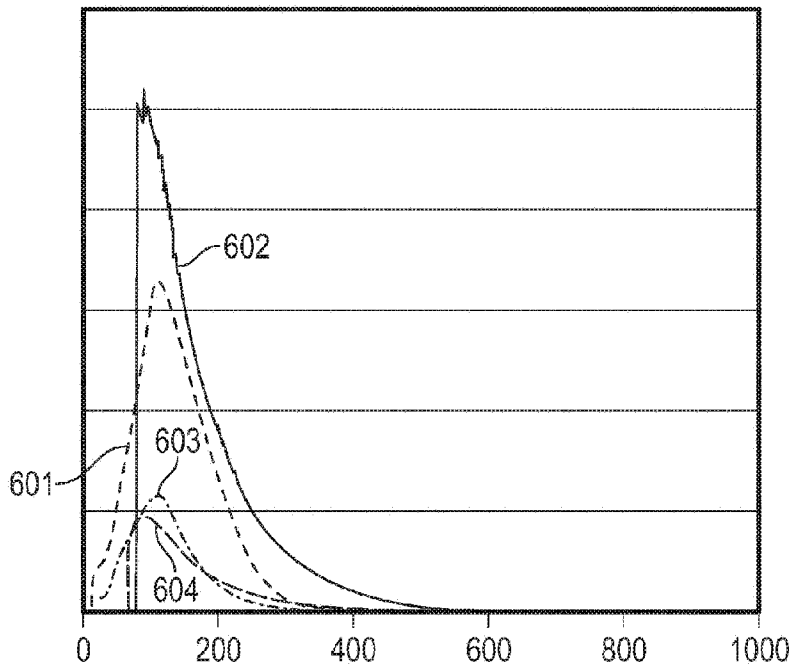

FIG. 6

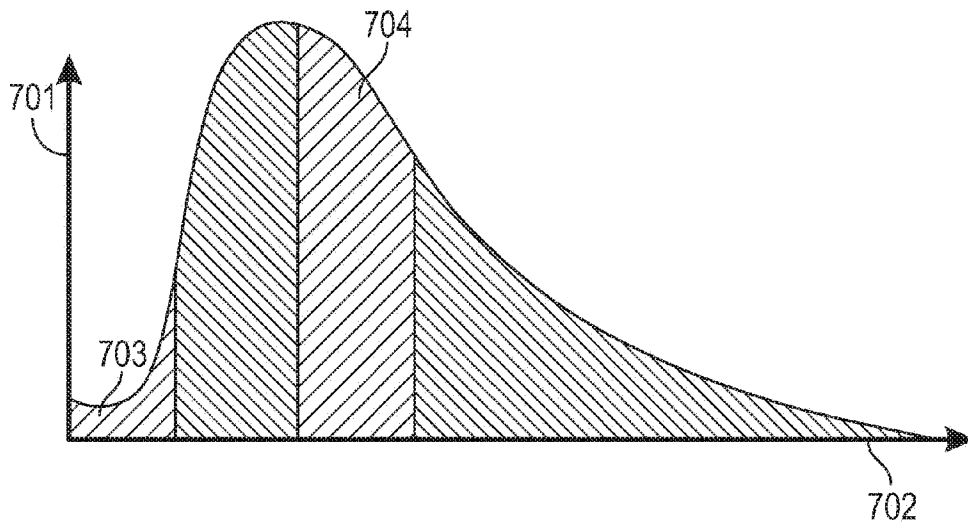

FIG. 7

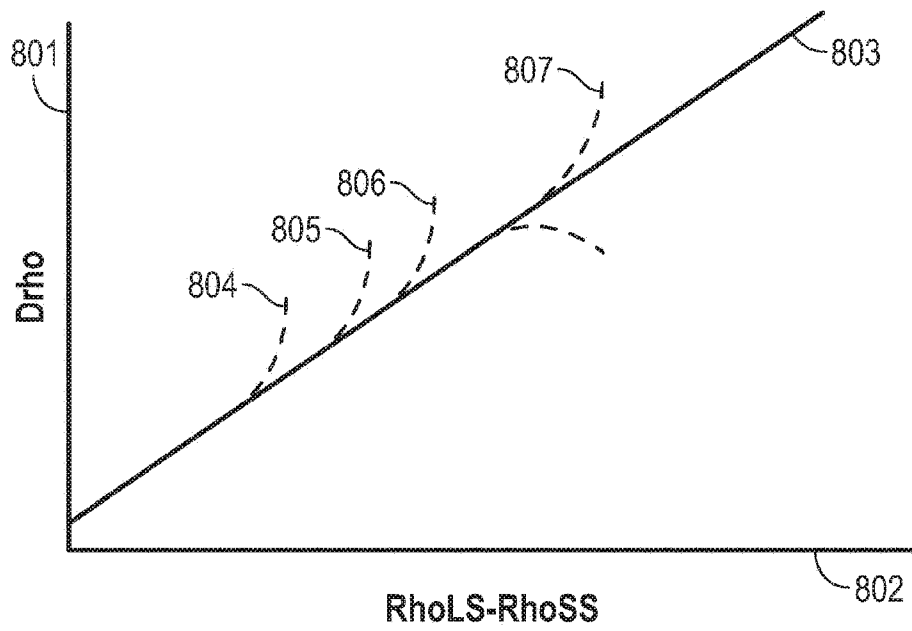

FIG. 8