

C. E. Gale,
Cartet Stretcher.

No. 111,337.

Patented Jan. 31, 1871.

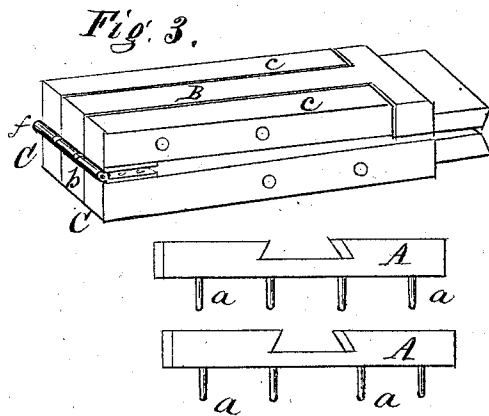
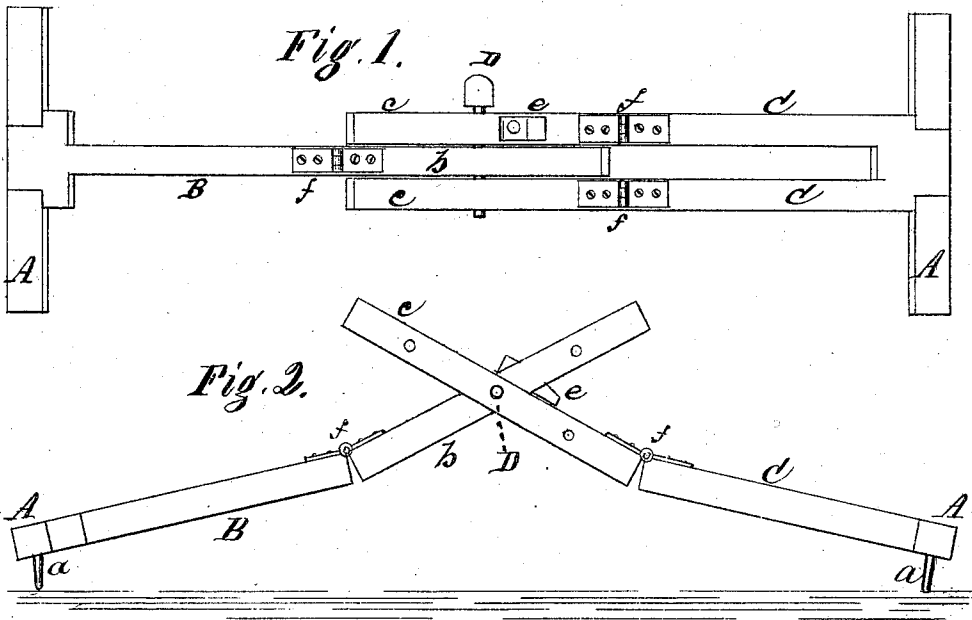

Witnesses.

D. H. Motthead
A. Allgauer

Inventor

Chas. E. Gale
per H. W. Morley
Atty.

United States Patent Office.

CHARLES E. GALE, OF AURELIUS, NEW YORK.

Letters Patent No. 111,337, dated January 31, 1871.

IMPROVEMENT IN CARPET-STRETCHERS.

The Schedule referred to in these Letters Patent and making part of the same.

To all whom it may concern:

Be it known that I, CHARLES E. GALE, of Aurelius, in the county of Cayuga and State of New York, have invented a new and improved Carpet-Stretcher; and I do hereby declare that the following is a full, clear, and exact description thereof, which will enable others to make and use the same, reference being had to the accompanying drawing forming a part of this specification, in which—

Figure 1 is a top view or plan of my invention;

Figure 2 is a side view; and

Figure 3 shows the parts detached and folded to occupy but little space when not in use.

Similar letters of reference indicate like parts in the several figures.

This invention consists in a light frame, that extends across the entire carpet, with one or more knee-joints at or near the center, and a toothed head-block at each end, for engaging with the carpet; the frame being extended, to stretch the carpet, by pressing down the joint at its center, as hereinafter more fully described.

In the accompanying drawing—

A A are the head-blocks, and

B b C c is the extensible frame.

The frame B b has a joint or hinge at *f*.

The frame C c is made in two parts, or doubled, as shown in fig. 1, to balance or prevent side strain on the joints, and has also hinge-joints *ff*.

The parts *b c* are connected with each other by a pin, D, at the center of the frame, and have a series of holes, so that the frame can be lengthened out or shortened, to fit the size of various carpets, by changing the pin D to a different set of holes.

Each head-block A is provided with teeth *a a*, and

has also a dovetailed recess, as shown in fig. 3; by which it is fixed to its frame in a detachable manner.

In using the apparatus, the frame is adjusted in length so as to nearly reach across the room. The center of the frame is then lifted, as shown in fig. 2, and on pressing it down the head-blocks engage with the carpet, and it is extended with any desired degree of power.

When pressed fully down, the weight of the frame is usually sufficient to hold the joint down; but a button, *e*, can be used to lock the parts until the carpet has been secured to the floor.

The parts fold up snug for shipping or to occupy but little room when not in use, as shown in fig. 3.

By these means a carpet is stretched very uniformly and with the greatest facility.

Having thus described my invention,

What I claim, and desire to secure by Letters Patent, is—

A carpet-stretcher composed of the jointed sections B b C c, capable of a double adjustment, the adjustable connecting-pin D, and teeth *a*, when the latter, fitted in heads A A, are applied to both ends of the stretcher, and adapted to be operated by depressing the central joint at the point of connection between the parts B b C c, and locked in position, substantially as herein shown and described.

The above specification of my invention signed by me this 28th day of November, 1870.

CHAS. E. GALE.

Witnesses:

D. L. MOORHEAD,

A. ALLGIEAR.