

(No Model.)

3 Sheets—Sheet 1.

C. H. KNOWLTON & B. F. MEYER.

LOOM.

No. 407,597.

Patented July 23, 1889.

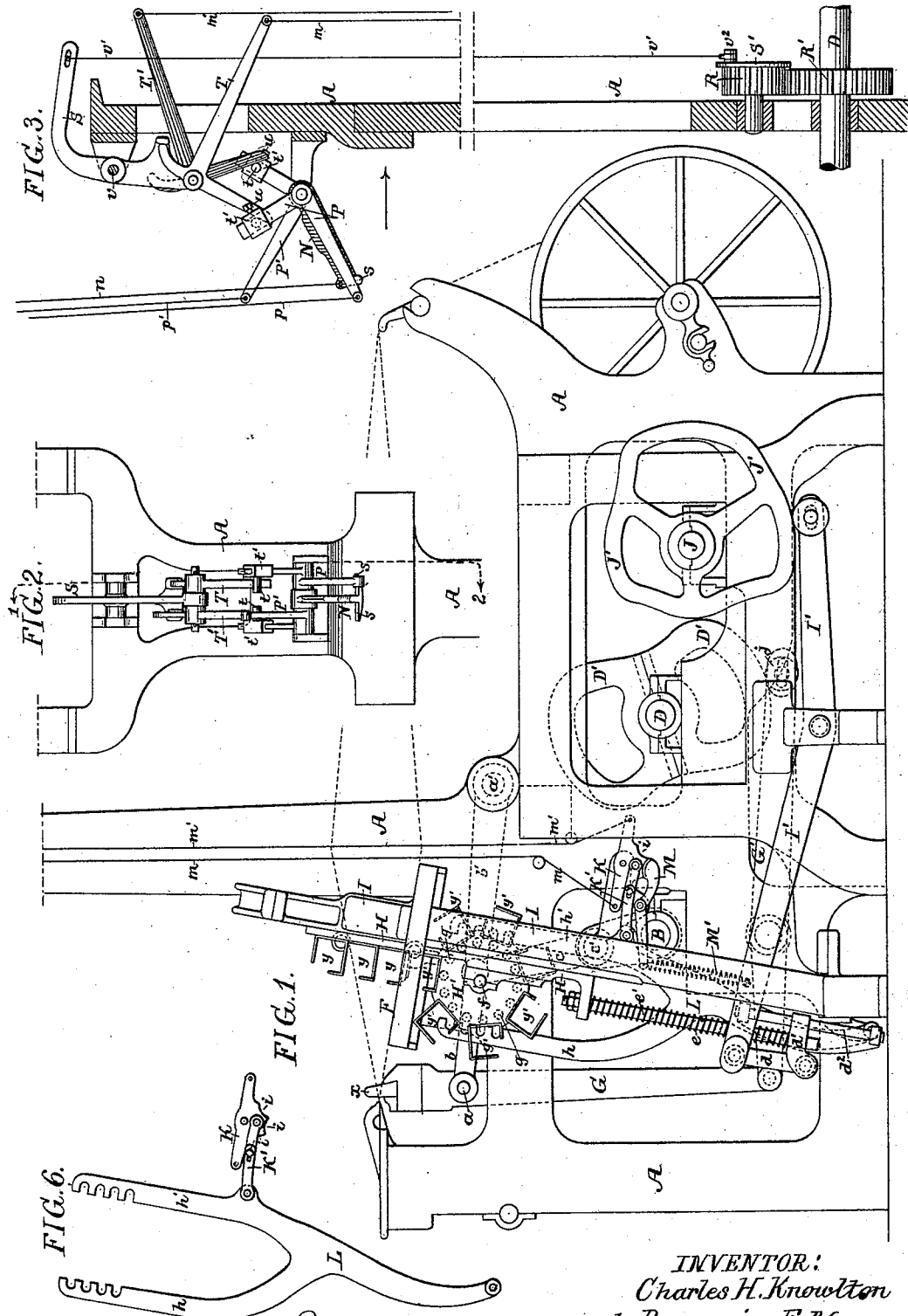

WITNESSES: *Atty. Barkoff*
William D. Bonner

INVENTOR:
Charles H. Knowlton
and Benjamin F. Meyer.
by their Atty's.
Howson & Sons

(No Model.)

3 Sheets—Sheet 3.

C. H. KNOWLTON & B. F. MEYER.

LOOM.

No. 407,597.

Patented July 23, 1889.

FIG. 7.

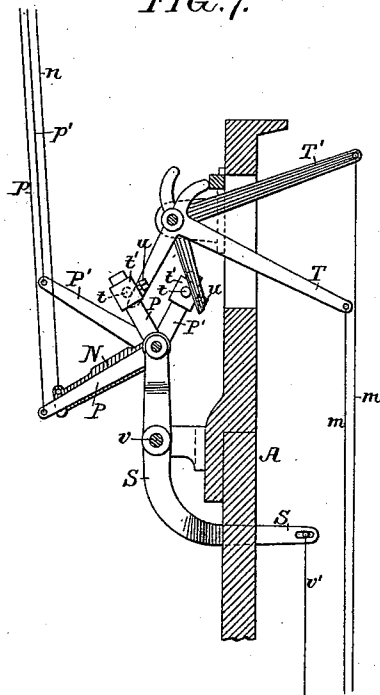

Witnesses:
William D. Bonner.
John E. Parker

Inventors:
Charles H. Knowlton &
Benjamin F. Meyer
by their Attorneys
Houson & Sonp

UNITED STATES PATENT OFFICE.

CHARLES H. KNOWLTON AND BENJAMIN F. MEYER, OF CAMDEN, NEW JERSEY, ASSIGNORS TO THE M. A. FURBUSH & SON MACHINE COMPANY, OF SAME PLACE.

LOOM.

SPECIFICATION forming part of Letters Patent No. 407,597, dated July 23, 1889.

Application filed December 2, 1886. Serial No. 220,467. (No model.)

To all whom it may concern:

Be it known that we, CHARLES H. KNOWLTON and BENJAMIN F. MEYER, citizens of the United States, and residents of Camden, New Jersey, have invented certain Improvements in Looms, of which the following is a specification.

Our invention relates to that class of looms in which a fixed shuttle-race and reed are combined with an independent comb for beating up the weft-thread, the object of our invention being to construct a high-speed loom of this class in which a large number of shuttle-boxes can be used.

In the accompanying drawings, Figure 1 is a side view of the lower part of a loom embodying our invention; Fig. 2, a side view of the inner part of the upper portion of the loom, looking in the direction of the arrow, Fig. 3, and illustrating a feature of our invention; Fig. 3, a transverse section of said upper part of the loom on the line 1 2, Fig. 2; Fig. 4, a front view of part of the loom with some of the parts broken away to show those behind; Fig. 5, a diagram showing the mechanism for operating the beating-up comb, and Fig. 6 a detached view of part of the shuttle-box-operating mechanism. Fig. 7 represents a modification in the construction of part of the loom.

A represents part of one of the side frames of the loom; B, the crank-shaft, adapted to suitable bearings thereon, and D a cam-shaft adapted to similar bearings. The shuttle-race F and the reed F' carried thereby are immovable, the shuttle-race forming part of the fixed frame of the loom and the beating up of the weft-thread being effected by a comb x , which is carried by a lathe G, pivoted to one arm of a lever G', the other arm of which carries an anti-friction roller j , acted upon by cams D' on the shaft D.

A pin a on the lathe G is connected to a fixed pin a' on the frame of the loom by means of links $b b'$, the jointed ends of which are connected by a third link c to the pin c' of a crank on the shaft B, the result of this mechanism being that as the shafts B and D are rotated a combined longitudinal vibrating

and vertical reciprocating movement substantially in the path shown by the dotted line x' in Fig. 5 is imparted to the comb x , so that after a filling-thread has been laid across the open shed by the passage of the shuttle the comb will rise into the shed behind said filling-thread, and will then be carried forward, so as to beat it up, after which the comb will descend to a point below the shed and will be retracted to the starting-point, ready to beat up another thread. This construction is substantially similar to that shown in the patent of J. C. Duckworth, No. 172,097, January 11, 1876, in which, however, the invention is illustrated as applied to a single-shuttle loom.

In the weaving of certain classes of fabrics (ingrain carpet, for instance) it is necessary to employ a large number of shuttles, and Duckworth, in adapting his loom for the performance of work of this class, adopted the construction shown in his patent, No. 211,718, January 28, 1879. In the loom shown in said patent two sets of shuttle-boxes, one in advance of the other, on each side of the loom were employed, and the shuttle-race and reed were vibrated so as to be brought into line with either set of shuttle-boxes; but this construction is objectionable, not only because of the duplication of the picking mechanism at each side of the loom which it necessitates, but also because it sacrifices one of the main advantages of the original Duckworth loom—that is to say, the fixed shuttle-race and reed.

In carrying out our invention we discard the construction shown in the last-mentioned patent, No. 211,718, and use in connection with the stationary shuttle-race and reed of the original Duckworth loom shuttle-box mechanism of a character substantially similar to that shown in Murkland's patent, No. 97,106, November 23, 1869, for we find that we are in this way enabled to attain the advantages of a loom constructed as in Patent No. 211,718, so far as regards the employment of a large number of shuttles, without the complexity, difficulty of working, and other objections which are inseparable from the construction shown in said Patent No. 211,718,

while at the same time we overcome certain objections to which the Murkland shuttle-box arrangement is subject when it is used in connection with a vibrating lathe, as usual.

5 The shuttle-box slide H is guided on a slightly-inclined fixed side frame I, and is operated by a shuttle-box cam J', carried by a shaft J at the rear of the loom, said cam acting through the medium of a lever I', which
10 is connected by a link *d* to an arm *d'*, guided on a rod *d²* of the frame and acting upon the lower end of a spring *e*, which is coiled round a guide-rod *e'*, carried by and projecting downward from the shuttle-box slide H, the
15 upper end of said spring bearing against said slide and serving as the medium through which the movement of the arm *d'* is imparted to the same.

The upper shuttle-boxes *y* of the set are secured directly to the upper end of the box-slide H; but the lower boxes *y'* are carried by a cylinder H', having trunnions *f*, adapted to bearings on the slide. As the slide H is reciprocated vertically, therefore, the cylinder
25 H' may be rotated in one direction or the other by the engagement of pins *g* on said cylinder with one or other of the notched arms *h h'* of a forked lever L, which is hung to a suitable stud near the base of the loom, the lever being moved so as to throw either
30 of its arms into engagement with the pins *g*, or so as to adjust the arms to an intermediate position in which both are free from engagement with said pins. These movements of
35 the lever L are determined by a dictating-lever K, hung to a pin on the fixed frame of the loom and connected to the lever L by a link K', said dictating-lever having recesses *i*, with one of which engages one arm of a
40 locking-lever M, hung to a fixed stud, the other arm of said lever being acted upon by a spring M', so that the lever, by engagement with one or other of the recesses *i*, serves to retain the dictating-lever in any one of the
45 three positions to which it may be adjusted.

By the use of shuttle-box mechanism of this character we are enabled to employ the desired large number of shuttles without resorting to the complicated, expensive, and
50 troublesome construction shown in the Duckworth patent of 1879. In operating the usual Murkland loom it has been found necessary to limit the speed of the same in order to prevent overrunning or derangement of the
55 box-cylinder H', and this objection we conceive to be due to the vibration of the lathe, which, in the ordinary Murkland loom, carries said box-cylinder. In our improved loom this objection is entirely overcome, and we
60 are enabled to run the loom at a much higher rate of speed than an ordinary loom with the Murkland arrangement of shuttle-boxes, this advantage arising from the fact that in our loom the bearings for the shuttle-box slide
65 are perfectly rigid; hence, whatever the speed at which the loom is run, there can be no such jarring of the box-cylinder as would

have a tendency to cause the same to over-run or would interfere with the proper engagement of the notched arms of the lever L
70 with the pins of said cylinder. It was also found in operating the Murkland loom that when the loom was thrown out of gear by the action of the weft-fork the movement of the loom was not arrested as quickly as was desirable, because of the difficulty of overcoming the momentum which had been acquired
75 by the swinging lathe and its heavy box-cylinder. This objection, it will be evident, is entirely overcome in our loom. 80

We are aware that it has heretofore been proposed to use in a loom a shuttle-box slide and cylinder adapted to bearings on the fixed frame of the loom, and we may refer to the patent of Hickey and Miles, No. 192,580, July
85 3, 1877, as an instance of such construction; but in this case, as in the construction shown in the Duckworth patent, No. 211,718, the shuttle-race moves back and forth, the Hickey and Miles loom being even more objectionable
90 than the Duckworth loom in this respect, for the reason that the shuttle-race and reed move with the lathe in beating up the weft. Where the shuttle-race is movable, the speed of the loom is limited, as the picker cannot
95 act until the shuttle-race comes to rest in line with the box, while the imperfect registering of the shuttle race and box, which is likely to occur when said shuttle-race is movable, causes the shuttle to be deflected and leave
100 the race. It will be evident that these objections do not apply to our loom, in which the shuttle-race is stationary.

The lever K, which controls the adjustment of the lever L for operating the box-cylinder,
105 is actuated by means of cords or wires *m m'*, which usually lead from the opposite arms of said lever K to the Jacquard mechanism of the loom; but said lever K cannot be operated except when the shuttle-boxes are at rest, and at such times the lifter-board of the Jacquard has almost completed its movement; hence we find it necessary to use in our loom, in connection with the ordinary Jacquard mechanism, supplemental devices,
115 whereby the necessary movement will be imparted to the lever K at the proper intervals. This mechanism is shown in Figs. 2 and 3, in which N represents an arm hung to a suitable pivot-pin carried by brackets on the
120 inner side of the frame of the loom and connected to one of the tails *n* of the Jacquard mechanism, bell-crank levers P P' being hung to the same pivot-pin as the arm N, one on each side of the latter, and being connected
125 to tails *p' p'* of the Jacquard mechanism.

The long arms of the levers P are prevented from dropping below the arm N by reason of supporting-lugs *s* on the latter, and the short arms of the levers are provided with slides
130 *t'*, having projecting pins *t*, these slides being adjustable on the arms of the levers and being secured in position after adjustment by means of suitable set-screws *u*.

Hung to a pin v , carried by a stud on the side frame A, is a lever S, the long arm of which is connected by a rod v' to a crank-pin v^2 on a disk S', which is secured to or forms part of a spur-pinion R, gearing into a spur-wheel R' on the cam-shaft D or any other available shaft of the loom. (See Fig. 3.)

The short arm of the lever S carries a pair of levers T T', the long arms of which are connected, respectively, to the cords or wires $m m'$ of the lever K, the short arms of said levers T T' projecting into the path of the pins t of the slides t' , carried, respectively, by the levers P P'.

The levers P P' can be lifted independently of each other by the tails $p p'$ when either lever is to act upon its corresponding lever T or T'; or both levers may be lifted simultaneously by means of the arm N when both levers T T' are to be acted on to adjust the lever K to the mid or inactive position shown in Fig. 1, the extent of lift of the levers in this case being less than when they are directly actuated, owing to the fact that the lifting-tail n of the arm N has more slack than the tails of the levers P P'.

It will be observed that the movement of the lever K is not due to the direct action of the jacquard, but to the vibration of the lever S, which carries the levers T T', against the pins t of the levers P P', and this vibration is so timed as to effect the operation of the lever K during the intervals between the operations of the shuttle-box slide H.

If desired, the arrangement shown may be reversed—that is to say, the pivot-pin of the arm N and levers P P' may be carried by the vibrating lever S, the levers T T' being hung to a fixed pivot. (See Fig. 7.) The levers T T' might also be operated by direct contact with the arms of the levers P P'; but the use on the latter of the adjustable slides with striking-pins is preferred, as it permits the extent of lift of the levers T T' to be readily governed.

The mechanism for operating the beating-up comb may be modified without departing

from our invention. For instance, the lathe G may be connected by a suitable rod directly to the pin c' of the crank-shaft B, the toggle-arms being dispensed with.

We claim as our invention—

1. The combination, in a loom, of a fixed shuttle-race and an independent beating-up comb and devices for operating the latter, a shuttle-box slide guided on the fixed frame of the loom and having boxes carried partly by said slide and partly by a cylinder hung thereto, mechanism for raising and lowering the shuttle-box slide on the fixed frame, a notched fork for engaging with the cylinder and turning the same as it is raised or lowered, and means for operating said fork, substantially as specified.

2. The combination of a shuttle-box slide having a cylinder hung thereto, means for operating said slide, a notched lever engaging with the box-cylinder to turn the same, a dictating-lever connected to said operating-lever, Jacquard levers having operating-tails, levers intermediate of the Jacquard levers and the dictating-lever, cords connecting said intermediate levers to the dictating-lever, a movable carrier for the Jacquard levers or intermediate levers, and means for operating said carrier, all substantially as specified.

3. The combination of the levers P P' and their supporting-arm, operating-tails connected to said arm and levers, the lever K, intermediate levers T T', connected by cords to the lever K and constructed for engagement with the levers P P', a lever S, carrying one set of said levers, and means for operating said lever S, so as to carry its set of levers from and toward the other set, all substantially as specified.

In testimony whereof we have signed our names to this specification in the presence of two subscribing witnesses.

CHARLES H. KNOWLTON.
BENJAMIN F. MEYER.

Witnesses:

WILLIAM D. CONNER,
HARRY SMITH.