



(12) EUROPEAN PATENT APPLICATION

(88) Date of publication A3:
07.04.1999 Bulletin 1999/14

(51) Int. Cl.⁶: F01P 7/16, F01P 3/20

(43) Date of publication A2:
10.03.1999 Bulletin 1999/10

(21) Application number: 98114838.0

(22) Date of filing: 06.08.1998

(84) Designated Contracting States:
AT BE CH CY DE DK ES FI FR GB GR IE IT LI LU
MC NL PT SE
Designated Extension States:
AL LT LV MK RO SI

(72) Inventor: Suzuki, Makoto
Toyota-shi, Aichi-ken, 471-8571 (JP)

(74) Representative:
Pellmann, Hans-Bernd, Dipl.-Ing. et al
Patentanwaltsbüro
Tiedtke-Bühling-Kinne & Partner
Bavariaring 4
80336 München (DE)

(30) Priority: 09.09.1997 JP 244319/97

(71) Applicant:
TOYOTA JIDOSHA KABUSHIKI KAISHA
Aichi-ken (JP)

(54) Apparatus for circulating cooling water for internal combustion engine

(57) An apparatus for circulating cooling water for an internal combustion engine (1) has a cooling water outer passageway (11), through which an engine body (3), a radiator (5), an indoor heater core (7) and an oil cooler (9) communicate with each other, for flowing the cooling water therethrough. The cooling water outer passageway (11) includes a going-to-engine-body communicating passageway (14) through which the cooling water flows from the radiator (5) towards the engine body (3), a going-to-heater-core communicating passageway (21) through which the cooling water flows from the engine body (3) towards the indoor heater core (7), and an oil cooler cooling water communicating passageway (30), bypasses the engine body communicating passageway (19) and the heater core

communicating passageway (32) with respect to a water jacket, including an oil cooler (9) midway of this oil cooler cooling water communicating passageway (30). The engine body communicating passageway (14) and the heater core communicating passageway (21) provided with flow rate control valves (15,23) for reducing a quantity of the cooling water when a temperature of the cooling water comes to a predetermined temperature. A connecting point between the oil cooler cooling water communicating passageway (30) and the heater core communicating passageway (21), exists more upstream than a point (M) at which the flow rate control valve (23) is disposed on the heater core communicating passageway (21).

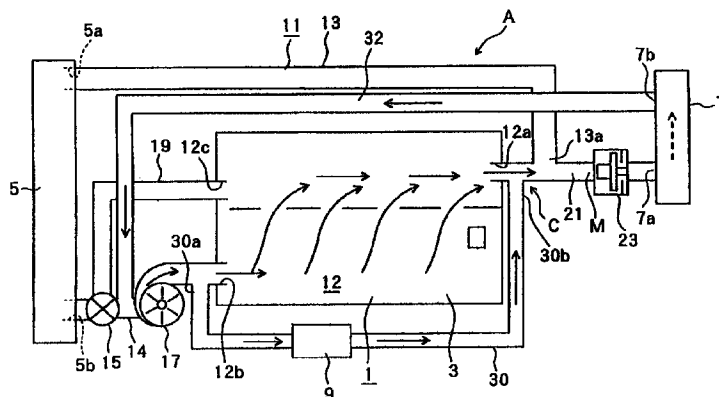



European Patent
Office

EUROPEAN SEARCH REPORT

Application Number
EP 98 11 4838

DOCUMENTS CONSIDERED TO BE RELEVANT			
Category	Citation of document with indication, where appropriate, of relevant passages	Relevant to claim	CLASSIFICATION OF THE APPLICATION (Int.Cl.6)
A	US 3 211 374 A (MATULAITIS) 12 October 1965 * column 3, line 57 - column 4, line 25; figures * ---	1, 2, 4, 5	F01P7/16 F01P3/20
A	DE 40 33 261 A (FREUDENBERG) 23 April 1992 * column 6, line 13 - line 56; figure 2A * ---	1	
A	PATENT ABSTRACTS OF JAPAN vol. 016, no. 021 (M-1201), 20 January 1992 & JP 03 235774 A (SUZUKI MOTOR CORP), 21 October 1991 * abstract; figure * ---	1	
A	US 4 697 551 A (LARSEN ET AL.) 6 October 1987 * figures * -----	1	
			TECHNICAL FIELDS SEARCHED (Int.Cl.6)
			F01P
The present search report has been drawn up for all claims			
Place of search THE HAGUE		Date of completion of the search 16 February 1999	Examiner Kooijman, F
CATEGORY OF CITED DOCUMENTS		T : theory or principle underlying the invention E : earlier patent document, but published on, or after the filing date D : document cited in the application L : document cited for other reasons ----- & : member of the same patent family, corresponding document	
X : particularly relevant if taken alone Y : particularly relevant if combined with another document of the same category A : technological background O : non-written disclosure P : intermediate document			

EPO FORM 1503 03.82 (P4/C01)

**ANNEX TO THE EUROPEAN SEARCH REPORT
ON EUROPEAN PATENT APPLICATION NO.**

EP 98 11 4838

This annex lists the patent family members relating to the patent documents cited in the above-mentioned European search report. The members are as contained in the European Patent Office EDP file on
The European Patent Office is in no way liable for these particulars which are merely given for the purpose of information.

16-02-1999

Patent document cited in search report	Publication date	Patent family member(s)	Publication date
US 3211374 A	12-10-1965	NONE	
DE 4033261 A	23-04-1992	NONE	
US 4697551 A	06-10-1987	DE 3620288 A GB 2178157 A	18-12-1986 04-02-1987