

(19)



(11)

EP 4 027 006 B1

(12)

EUROPEAN PATENT SPECIFICATION

(45) Date of publication and mention of the grant of the patent:
05.03.2025 Bulletin 2025/10

(51) International Patent Classification (IPC):
F03D 1/06 (2006.01)

(21) Application number: **21150476.6**

(52) Cooperative Patent Classification (CPC):
F03D 1/06495; F05B 2240/304; F05B 2240/3062; Y02E 10/72

(22) Date of filing: **07.01.2021**

(54) **A WIND TURBINE ROTOR BLADE WITH TWO ROWS OF VORTEX GENERATORS**

ROTORSCHAUFEL EINER WINDTURBINE MIT ZWEI REIHEN VON WIRBELGENERATOREN

PALE DE ROTOR D'ÉOLIENNE AYANT DEUX RANGÉES DE GÉNÉRATEURS DE VORTEX

(84) Designated Contracting States:
AL AT BE BG CH CY CZ DE DK EE ES FI FR GB GR HR HU IE IS IT LI LT LU LV MC MK MT NL NO PL PT RO RS SE SI SK SM TR

(72) Inventor: **Doosttalab, Mehdi**
22850 Norderstedt (DE)

(43) Date of publication of application:
13.07.2022 Bulletin 2022/28

(74) Representative: **Hauck**
Patentanwaltpartnerschaft mbB
Postfach 11 31 53
20431 Hamburg (DE)

(73) Proprietor: **Nordex Energy SE & Co. KG**
22419 Hamburg (DE)

(56) References cited:
EP-A1- 3 473 849 EP-A1- 3 473 850
EP-B1- 2 129 908 EP-B1- 3 037 565
US-A1- 2011 229 321 US-A1- 2015 003 985

EP 4 027 006 B1

Note: Within nine months of the publication of the mention of the grant of the European patent in the European Patent Bulletin, any person may give notice to the European Patent Office of opposition to that patent, in accordance with the Implementing Regulations. Notice of opposition shall not be deemed to have been filed until the opposition fee has been paid. (Art. 99(1) European Patent Convention).

Description

[0001] The invention relates to a wind turbine rotor blade with two rows of vortex generators.

5 **[0002]** For optimum performance under various operating conditions, wind turbine rotor blades need to fulfil complex structural and aerodynamic requirements. With regard to the profile thickness, for example, a compromise has to be made between aerodynamic and structural performance. In an inner radius section of wind turbine rotor blades, structural requirements call for profiles having a large relative thickness of more than e.g. 30 %, while the strong curvature of these profiles may lead to flow separation. Flow separation has also been observed in various other surface regions of wind turbine rotor blades. To counteract such flow separation, it is well known to place vortex generators on the blade surface.

10 **[0003]** The vortex generators are positioned obliquely, so that they have an angle of attack with respect to the local airflow, in order to create a vortex which draws energetic, rapidly moving outside air into the slow-moving boundary layer in contact with the blade surface. Vortex generators are used to trigger the transition from laminar flow to turbulent flow. A turbulent boundary layer is less likely to separate than a laminar one. As a consequence, a higher lift can be obtained. However, the vortex generators at the same time increase drag. For best results, vortex generators are generally positioned just before of an imaginary line where flow separation is expected.

15 **[0004]** The document EP 3 037 565 B1 discloses a wind turbine rotor blade having a main vortex generator configured to generate a main vortex and a secondary vortex generator configured to generate a second vortex, wherein the main vortex generator has a greater height than the secondary vortex generator.

20 **[0005]** The document EP 2 129 908 B1 discloses a wind turbine rotor blade with two rows of vortex generators. The vortex generators of both rows have a relatively small height and for this reason are called micro vortex generators.

[0006] The document US 2011/0229321 A1 discloses a wind turbine rotor blade in accordance with the preamble of claim 1. The vortex generators of the second row are placed just behind the vortex generators of the first row.

[0007] Starting therefrom, it is an object of the invention to improve the aerodynamic efficiency of a wind turbine rotor blade having two rows of vortex generators.

25 **[0008]** This object is solved by the wind turbine rotor blade with the features of claim 1. Preferred aspects of the invention are given in the dependent claims.

[0009] The wind turbine rotor blade has a blade root, a blade tip, a leading edge, a trailing edge, a first row of vortex generators and a second row of vortex generators,

- wherein the first row and the second row extend in a generally spanwise direction and the first row is arranged closer to the leading edge than the second row,
 - wherein the first row comprises two adjacent vortex generators each having a longitudinal axis extending in a generally chordwise direction and two first fins arranged symmetrically to the longitudinal axis, wherein each of the two first fins has a leading end and a trailing end, wherein the trailing ends are arranged in a distance d from each other, wherein the distance d is larger than a distance between the leading ends, wherein the two longitudinal axes are arranged in a distance D from each other and define a centre line extending in a generally chordwise direction,
 - wherein the second row of vortex generators comprises a second fin having a leading end and a trailing end, wherein the trailing end is arranged closer to the centre line than the leading end,
 - wherein the second fin is positioned with reference to the first fin that is arranged on the same side of the centre line as the second fin and with its trailing end closer to the centre line than its leading end such that the trailing end of the second fin is arranged in a chordwise distance c from the trailing end of that first fin,
 - wherein a distance x of the trailing end of the second fin from the centre line is within a range between
- (i) an upper limit x_u defined by:

45
$$\begin{array}{ll} x_u \leq 0.30 D & \text{for } c > 1.43 D - 3.57d \\ x_u \leq D/2 - d/2 - 0.14 c & \text{for } c \leq 1.43 D - 3.57 d \text{ and} \end{array}$$

(ii) a lower limit x_L defined by

50
$$\begin{array}{ll} x_L \geq 0.07 D & \text{for } c > 0.75 D - 0.87 d \\ x_L \geq D/2 - d/2 - 0.58 c & \text{for } c \leq 0.75 D - 0.87 d. \end{array}$$

55 **[0010]** The wind turbine rotor blade in particular is designed for a wind turbine rotor with a horizontal axis. The blade root can be adapted for being fastened on a rotor hub. The spanwise direction generally extends from the blade root towards the blade tip, in particular parallel to a pitch axis or longitudinal axis of the wind turbine rotor blade. The wind turbine rotor blade has an aerodynamic profile with a suction side, a pressure side and a chord extending between a profile leading edge and a profile trailing edge. The chordwise direction corresponds to the direction of this chord, and is perpendicular to the

longitudinal axis/pitch axis of the wind turbine rotor blade.

[0011] The first row and the second row of vortex generators extend in a generally spanwise direction. In other words, the vortex generators of each row are placed along a line on the wind turbine rotor blade surface running from a first point closer to the blade root to a second point closer to the blade tip. These lines may be straight and/or parallel to the longitudinal axis/pitch axis of the wind turbine rotor blade. However, they may as well be inclined with regard to the longitudinal axis/pitch axis and/or comprise a curvature and/or one or more kinks. For example, the lines may be positioned at a fixed distance from the leading edge, either in absolute terms or in relation to the chord length varying in the spanwise direction. The distance from the leading edge may also vary in the spanwise direction, for example may it increase with increasing distance from the blade root. In this context, the feature that the first row is arranged closer to the leading edge than the second row means that a vortex generator of the first row at a given spanwise position is closer to the leading edge than a vortex generator of the second row at substantially the same spanwise position, so that the air flow reaches the second row only after having passed the first row.

[0012] The first row comprises a plurality of vortex generators each having a longitudinal axis arranged in a generally chordwise direction. In other words, the vortex generators are aligned with a direction of the surrounding air flow, wherein some deviation between the direction of air flow, the longitudinal axis and/or the chordwise direction is possible.

[0013] Each vortex generator of the first row comprises two first fins placed symmetrically with regard to its longitudinal axis. The first fins may be connected to each other via a base plate or via any other supporting structure mounted to the wind turbine rotor blade surface, but they may as well be mounted individually on the wind turbine rotor blade surface, without any other connecting member between the two first fins.

[0014] The first fins as well as the second fin may be essentially planar, but they may also include some curvature. They are placed at an angle with reference to the longitudinal axis and hence to the direction of air flow. This angle may be in a range of about 10° to about 40°, for example. The fins may be placed generally perpendicular to a wind turbine rotor blade surface, in particular on the suction side. Each of the fins has a leading end and a trailing end, based upon where the air flow passes first. The leading end is the foremost part of the fin, the trailing end is the backmost part of the fin. As the fin may have any shape, e.g. rectangular, triangular, trapezoidal and/or including some curvature, the leading end may be a point or an edge. The same holds for the trailing end. The distance d is measured between the trailing ends of the first fins of a vortex generator of the first row of vortex generators. It corresponds to the overall width of these vortex generators.

[0015] The longitudinal axes of two adjacent vortex generators of the first row define a centre line arranged halfway between the two longitudinal axes. If the longitudinal axes are exactly parallel, the centre line will be parallel to both of them. It is also possible that an angle is formed between the two longitudinal axes, should one or both of them deviate from the chordwise direction, e.g. by a few degrees. In this case, the centre line will be a bisecting line.

[0016] The vortex generators of the second row comprise a second fin having a leading end and a trailing end, wherein the trailing end is arranged closer to the centre line. For defining the position of the trailing end of the second fin, reference is made to the position of the trailing end of one of the first fins, namely of the first fin that is on the same side of the centre line and also has its trailing end closer to the centre line than its leading end. The chordwise distance between the trailing end of this first fin and the trailing end of the second fin is denoted distance c. It is measured along the wind turbine rotor blade surface, which may include some curvature. Hence, the chordwise distance c may not follow a straight line, but corresponds to an overall direction of air flow.

[0017] In accordance with the invention, the spanwise position of the trailing end of the second fin lies in a specified area defined in terms of the spanwise distance x of this trailing end from the centre line. The spanwise distance x shall be measured along the wind turbine rotor blade surface as well, as has been explained for the chordwise distance c. The range of the spanwise distance x within the specified area is defined by upper and lower limits which depend on the chordwise distance c as indicated above. Both limits include a fixed value for the spanwise distance x which applies further away from the first row, and a value depending linearly on the chordwise distance c which applies closer to the first row. Together, the upper and lower limits define a strip-shaped surface area beginning at the trailing end of the specified first fin of the vortex generator of the first row, and then broadening with increasing distance from this trailing end.

[0018] In operation, the area defined by the upper and lower limits corresponds to an extension of a vortex generated by the first fin. When the second fin has the same orientation with reference to the direction of air flow as the first fin, it tends to generate a vortex with the same rotation direction, either clockwise or counter-clockwise. Placing the trailing end of the second fin in the specified area therefore does not generate a new vortex, but rather strengthens or re-energises the vortex generated by the first fin. For this reason, it is believed that the second row of vortex generators helps avoiding flow separation while generating less additional drag than a second row of vortex generators placed outside of the specified area.

[0019] In an aspect of the invention, the upper limit x_u is defined by

$$\begin{aligned} x_u &\leq 0.18 D && \text{for } c > 1.19D - 1.87d \\ x_u &\leq D/2 - d/2 - 0.27 c && \text{for } c \leq 1.19D - 1.87 d. \end{aligned}$$

[0020] This means the area in which the trailing end of the second fin is placed is narrower, so that the strengthening of the vortex generated by the first fin is even more efficient and/or applies a larger range of operating conditions. The slope of $-0.27 c$ corresponds to an angle α of 15° (see below explanation of Fig. 3).

[0021] In an aspect of the invention, the lower limit x_L is defined by

5

$$\begin{array}{ll} x_L \geq 0.10D & \text{for } c > 0.85 D - 1.06 d \\ x_L \geq D/2 - d/2 - 0.47 c & \text{for } c \leq 0.85 D - 1.06 d. \end{array}$$

10 **[0022]** This means the area in which the trailing end of the second fin is placed is even narrower, so that the strengthening of the vortex generated by the first fin is even more efficient and/or applies to an even larger range of operating conditions. The slope of $-0.47 c$ corresponds to an angle β of 25° (see below explanation of Fig. 3).

[0023] In accordance with the invention, the chordwise distance c is larger than twice the distance d . It has been found that the vortex strengthening effect works best when the distance c is at least as large as the distance d .

15 **[0024]** In an aspect of the invention, the second row comprises a plurality of second fins, wherein each of the second fins is arranged with reference to one of the first fins as defined in claim 1. In this way, each of the second fins strengthens a vortex generated by one of the first fins.

[0025] In an aspect of the invention, the two vortex generators of the first row are arranged in a longitudinal section of the wind turbine rotor blade in which the wind turbine rotor blade has an aerodynamic profile with a relative thickness of 0.35 or more. The relative thickness may also be 0.45 or larger. For this type of profiles, the second row of vortex generators is particularly useful.

20 **[0026]** In an aspect of the invention, the aerodynamic profile has a flat trailing edge. The flat trailing edge helps limiting the curvature of the suction side and therefore avoiding flow separation. In combination with the inventive positioning of the second fin, optimal aerodynamic efficiency can be obtained.

25 **[0027]** In an aspect of the invention, the flat trailing edge has a thickness of at least 2 % of a chord length of the aerodynamic profile. The thickness may also be at least 10 % or at least 15 % of the chord length.

[0028] In an aspect of the invention, a vortex generator of the first row comprises a base plate mounted on a wind turbine rotor blade surface, wherein the two first fins of the vortex generator are connected to the base plate. This type of vortex generator is easy to install.

30 **[0029]** In an aspect of the invention, a vortex generator of the second row comprises a base plate mounted on a wind turbine rotor blade surface, wherein a single second fin is connected to the base plate. In other words, each of the second fins of the second row of vortex generators is installed by means of a separate base plate. The defined spanwise positions of the second fins may include relatively large distances between adjacent second fins. Installing the second fins individually by means of separate, relatively small base plates instead of in pairs with relatively wide base plates can therefore lead to less disturbance of the air flow between adjacent second fins.

35 **[0030]** In the following, the invention is explained in greater detail based on an embodiment shown in figures. The figures show:

Fig. 1 a wind turbine rotor blade in a schematic, perspective view,

40

Fig. 2 the wind turbine rotor blade of Fig. 1 in cross section,

Fig. 3 the wind turbine rotor blade of Fig. 1 in a schematic view on a section of the suction side.

45 **[0031]** The wind turbine rotor blade 10 of Fig. 1 has a blade root 12, a blade tip 14 and a pitch axis 68. The pitch axis 68 may also be referred to as longitudinal axis of the wind turbine rotor blade 10. At the blade root 12, the wind turbine rotor blade 10 has a cylindrical cross section and is adapted for attachment to a wind turbine rotor hub (not shown). The cross section with increasing distance from the blade root 12 transforms into an aerodynamic profile, as illustrated by the dotted lines. The surface of the wind turbine rotor blade 10 facing the viewer forms a suction side 16, the opposite surface of the wind turbine rotor blade 10 forms a pressure side 18. The pressure side 16 and the suction side 18 both extend from a leading edge 20 to a trailing edge 22.

50 **[0032]** A first row 24 of vortex generators and a second row 26 of vortex generators are arranged in a generally spanwise direction in a longitudinal section 28 of the wind turbine rotor blade 10, on the suction side 16. The first row 24 of vortex generators is positioned closer to the leading edge 20 than the second row 26 of vortex generators. In the embodiment of Fig. 1, each vortex generator of the first row 24 and of the second row 26 comprises two fins. However, this is not mandatory in particular for the second row 26, in which one or more of the vortex generators may consist each of a single second fin only.

55 **[0033]** The cross section of Fig. 2 lies within the longitudinal section 28 of the wind turbine rotor blade 10, close to the

blade root 12. At this longitudinal position, the aerodynamic profile has a relative thickness of about 40 %, calculated as the profile thickness 70 divided by the chord length 72, and a flat trailing edge 22 with a height 74 of about 20 % of the chord length 32.

[0034] On the suction side 16, one can see a first fin 30 of a vortex generator of the first row 24. The first fin 30 has a trapezoidal shape with a leading end 34 formed by a short edge arranged approximately perpendicular to the surface of the suction side 16, and a trailing end 36 arranged approximately perpendicular to the surface of the suction side 16. One can also see a second fin 32 of a vortex generator of the second row 26. The second fin 32 has a trapezoidal shape with a leading end 38 formed by a short edge arranged approximately perpendicular to the surface of the suction side 16, and a trailing end 40 arranged approximately perpendicular to the surface of the suction side 16. The chordwise distance c is measured between the trailing ends 36 and 40 along the wind turbine rotor blade's surface.

[0035] Figure 3 shows the positions of the vortex generators in greater detail, looking onto a section of the suction side 16 of the wind turbine rotor blade 10. The leading edge 20 is shown to the left, the trailing edge 22 is shown to the right of Fig. 3. The first row 24 of vortex generators comprises a vortex generator having a first fin 30 and a further first fin 42 arranged symmetrically to a longitudinal axis 44 of this vortex generator.

[0036] The distance d is indicated between the trailing end 36 of first fin 30 and the trailing end of first fin 42. It corresponds to a width of the vortex generator.

[0037] Another, adjacent vortex generator of the first row 24 of vortex generators is arranged in a spanwise distance D . It comprises two fins 46, 48 and a longitudinal axis 50. The longitudinal axes 44, 50 of both vortex generators of the first row 24 of vortex generators are arranged in a generally chordwise direction. They define a centre line 52 arranged halfway between the longitudinal axes 44, 50. The spanwise distance D is measured between the longitudinal axes 44, 50.

[0038] The second row 26 of vortex generators comprises a second fin 32 having a leading end 38 and a trailing end 40. The trailing end 40 is arranged in a spanwise distance x from the centre line 52, and in a chordwise distance c from the trailing end 36 of the first fin 30. The trailing end 40 is arranged in a specific surface area 54 shown with a shading. The range of spanwise positions x within the surface area 54 is defined by an upper limit x_u given by a first line 56 and a second line 58 and by a lower limit x_L given by a third line 60 and a fourth line 62.

[0039] The first line 56 is described by the term $x_u = D/2 - d/2 - 0.14 c$ and applies as an upper limit x_u for the spanwise distance x where $c \leq 1.43 D - 3.57 d$. The slope of $-0.14 c$ corresponds to an angle $\alpha = 8^\circ$. The second line 58 is described by the term $x_u = 0.30 D$.

[0040] The third line 60 is described by the term $x_L = D/2 - d/2 - 0.58 c$ and applies as a lower limit x_L for the spanwise distance x where $c \leq 0.75 D - 0.87 d$. The slope of $-0.58 c$ corresponds to an angle $\beta = 30^\circ$. The fourth line 62 is described by the term $x_L = 0.07 D$.

[0041] When looking from the leading edge 20 at the air flow close to the suction side 16, the first fin 30 will generate a vortex rotating counter-clockwise and roughly covering the surface area 54 when flowing towards the trailing edge 22. The second fin 32 with its trailing end 40 arranged within this surface area 54 will not generate a new vortex, but will strengthen the vortex generated by the first fin 30.

[0042] One can see from Fig. 3 that each of the second fins comprised in the second row 26 of vortex generators is arranged with reference to one of the first fins 30, 42, 46, 48 of the first row 24 of vortex generators, as has been explained in detail for the second fin 32, that is in a specific surface area shown with a shading.

[0043] Figure 3 also shows that the vortex generators of the first row 24 of vortex generators each comprise two first fins (30/42, and 46/48, respectively) connected to a common base plate 64, while each of the second fins of the vortex generators of the second row 26 of vortex generators is connected to a separate base plate 66.

List of reference numerals

[0044]

- 10 wind turbine rotor blade
- 12 blade root
- 14 blade tip
- 16 suction side
- 18 pressure side
- 20 leading edge
- 22 trailing edge
- 24 first row of vortex generators
- 26 second row of vortex generators
- 28 longitudinal section
- 30 first fin
- 32 second fin

34	leading end of first fin 30
36	trailing end of first fin 30
38	leading end of second fin 32
40	trailing end of second fin 32
5	42 first fin
	44 longitudinal axis
	46 first fin
	48 first fin
	50 longitudinal axis
10	52 centre line
	54 surface area
	56 first line
	58 second line
	60 third line
15	62 fourth line
	64 common base plate
	66 separate base plate
	68 pitch axis
	70 profile thickness
20	72 chord length
	74 height
	α, β angles
	x distance of the trailing end of the second fin from the centre line
	xu upper limit of the value x
25	x_L lower limit of the value x

Claims

1. A wind turbine rotor blade (10) comprising a blade root (12), a blade tip (14), a leading edge (20), a trailing edge (22), a first row (24) of vortex generators and a second row (26) of vortex generators,
- wherein the first row (24) and the second row (26) extend in a generally spanwise direction and the first row (24) is arranged closer to the leading edge (20) than the second row (26),
 - wherein the first row (24) comprises two adjacent vortex generators each having a longitudinal axis (44, 50) extending in a generally chordwise direction and two first fins (30, 42, 46, 48) arranged symmetrically to the longitudinal axis (44, 50), wherein each of the two first fins (30, 42, 46, 48) has a leading end (34) and a trailing end (36), wherein the trailing ends (36) are arranged in a distance d from each other, wherein the distance d is larger than a distance between the leading ends (34), wherein the two longitudinal axes (44, 50) are arranged in a distance D from each other and define a centre line (52) extending in a generally chordwise direction,
 - wherein the second row (24) of vortex generators comprises a second fin (32) having a leading end (38) and a trailing end (40), wherein the trailing end (40) is arranged closer to the centre line (52) than the leading end (38),
 - wherein the second fin (32) is positioned with reference to the first fin (30) that is arranged on the same side of the centre line (52) as the second fin (32) and with its trailing end (40) closer to the centre line (52) than its leading end (38) such that the trailing end (40) of the second fin (32) is arranged in a chordwise distance c from the trailing end (36) of that first fin (30), **characterised in that**
 - the chordwise distance c is larger than twice the distance d and
 - a distance x of the trailing end (40) of the second fin (32) from the centre line (52) is within the range between

(i) an upper limit x_U defined by:

$$x_U \leq 0.30 D \quad \text{for } c > 1.43 D - 3.57 d$$

$$x_U \leq D/2 - d/2 - 0.14 c \quad \text{for } c \leq 1.43 D - 3.57 d \text{ and}$$

(ii) a lower limit x_L defined by

$$x_L \geq 0.07 D \quad \text{for } c > 0.75 D - 0.87 d$$

(continued)

$$x_L \geq D/2 - d/2 - 0.58 c \quad \text{for } c \leq 0.75 D - 0.87 d.$$

- 5 2. The wind turbine rotor blade (10) of claim 1, **characterised in that** the upper limit x_U is defined by

$$\begin{aligned} x_U &\leq 0.18 D && \text{for } c > 1.19 D - 1.87 d \\ x_U &\leq D/2 - d/2 - 0.27 c && \text{for } c \leq 1.19 D - 1.87 d. \end{aligned}$$

- 10 3. The wind turbine rotor blade (10) of claim 1 or 2, **characterised in that** the lower limit x_L is defined by

$$\begin{aligned} x_L &\geq 0.10 D && \text{for } c > 0.85 D - 1.06 d \\ x_L &\geq D/2 - d/2 - 0.47 c && \text{for } c \leq 0.85 D - 1.06 d. \end{aligned}$$

- 15 4. The wind turbine rotor blade (10) of any of the claims 1 to 3, **characterised in that** the second row (26) comprises a plurality of second fins (32), wherein each of the second fins (32) is arranged with reference to one of the first fins (30, 42, 46, 48) as defined in claim 1.

- 20 5. The wind turbine rotor blade (10) of any of the claims 1 to 4, **characterised in that** the two vortex generators of the first row (24) are arranged in a longitudinal section (28) of the wind turbine rotor blade in which the wind turbine rotor blade (10) has an aerodynamic profile with a relative thickness of 0.35 or more.

- 25 6. The wind turbine rotor blade (10) of any of the claims 1 to 5, **characterised in that** the aerodynamic profile has a flat trailing edge (22).

7. The wind turbine rotor blade (10) of any of the claims 1 to 6, **characterised in that** the flat trailing edge (22) has a thickness of at least 2 % of a chord length (72) of the aerodynamic profile.

- 30 8. The wind turbine rotor blade (10) of any of the claims 1 to 7, **characterised in that** a vortex generator of the first row (24) comprises a base plate (64) mounted on a wind turbine rotor blade surface, wherein the two first fins (30, 42) of the vortex generator are connected to the base plate (64).

- 35 9. The wind turbine rotor blade (10) of any of the claims 1 to 8, **characterised in that** a vortex generator of the second row (26) comprises a base plate (66) mounted on a wind turbine rotor blade surface, wherein a single second fin (32) is connected to the base plate (66).

40 Patentansprüche

1. Windenergieanlagenrotorblatt (10), umfassend eine Blattwurzel (12), eine Blattspitze (14), eine Vorderkante (20), eine Hinterkante (22), eine erste Reihe (24) von Wirbelgeneratoren und eine zweite Reihe (26) von Wirbelgeneratoren,

- 45
- wobei sich die erste Reihe (24) und die zweite Reihe (26) in einer generellen Spannweitenrichtung erstrecken und die erste Reihe (24) näher an der Vorderkante (20) angeordnet ist als die zweite Reihe (26),
 - wobei die erste Reihe (24) zwei benachbarte Wirbelgeneratoren umfasst, die jeweils eine in einer generellen Sehnenrichtung verlaufende Längsachse (44, 50) und zwei symmetrisch zur Längsachse (44, 50) angeordnete erste Finnen (30, 42, 46, 48) aufweisen, wobei jede der beiden ersten Finnen (30, 42, 46, 48) ein vorderes Ende (34) und ein hinteres Ende (36) aufweist, wobei die hinteren Enden (36) in einem Abstand d voneinander angeordnet sind, wobei der Abstand d größer ist als ein Abstand zwischen den vorderen Enden (34), wobei die beiden Längsachsen (44, 50) in einem Abstand D voneinander angeordnet sind und eine Mittellinie (52) definieren, die sich in einer generellen Sehnenrichtung erstreckt,
- 50
- wobei die zweite Reihe (26) von Wirbelgeneratoren eine zweite Finne (32) mit einem vorderen Ende (38) und einem hinteren Ende (40) umfasst, wobei das hintere Ende (40) näher an der Mittellinie (52) angeordnet ist als das vordere Ende (38),
 - wobei die zweite Finne (32) in Bezug auf die erste Finne (30) positioniert ist, die auf derselben Seite der Mittellinie
- 55

(52) wie die zweite Finne (32) und mit ihrem hinteren Ende (40) näher an der Mittellinie (52) als mit ihrem vorderen Ende (38) angeordnet ist, so dass das hintere Ende (40) der zweiten Finne (32) in einem sehnenweisen Abstand c von dem hinteren Ende (36) dieser ersten Finne (30) angeordnet ist, **dadurch gekennzeichnet, dass**

- der sehnenweise Abstand c größer als das Doppelte des Abstands d ist und
- ein Abstand x des hinteren Endes (40) der zweiten Finne (32) von der Mittellinie (52) innerhalb des Bereichs liegt zwischen

(i) einer oberen Grenze x_U definiert durch:

$$\begin{aligned} x_U &\leq 0.30D && \text{for } c > 1.43D - 3.57d \\ x_U &\leq D/2 - d/2 - 0.14c && \text{for } c \leq 1.43 D - 3.57d \end{aligned}$$

und

(ii) einer unteren Grenze x_L definiert durch:

$$\begin{aligned} x_L &\geq 0.07D && \text{for } c > 0.75D - 0.87d \\ x_L &\geq D/2 - d/2 - 0.58c && \text{for } c < 0.75D - 0.87d. \end{aligned}$$

2. Windenergieanlagenrotorblatt (10) nach Anspruch 1, **dadurch gekennzeichnet, dass** die obere Grenze x_U definiert ist durch

$$\begin{aligned} x_U &\leq 0.18D && \text{for } c > 1.19D - 1.87d \\ x_U &\leq D/2 - d/2 - 0.27c && \text{for } c \leq 1.19D - 1.87d. \end{aligned}$$

3. Windenergieanlagenrotorblatt (10) nach Anspruch 1 oder 2, **dadurch gekennzeichnet, dass** die untere Grenze x_L definiert ist durch

$$\begin{aligned} x_L &\geq 0.10D && \text{for } c > 0.85D - 1.06d \\ x_L &\geq D/2 - d/2 - 0.47c && \text{for } c \leq 0.85D - 1.06d. \end{aligned}$$

4. Windenergieanlagenrotorblatt (10) nach einem der Ansprüche 1 bis 3, **dadurch gekennzeichnet, dass** die zweite Reihe (26) eine Vielzahl von zweiten Finnen (32) umfasst, wobei jede der zweiten Finnen (32) unter Bezugnahme auf eine von den ersten Finnen (30, 42, 46, 48) im Sinne des Anspruchs 1 angeordnet ist.

5. Windenergieanlagenrotorblatt (10) nach einem der Ansprüche 1 bis 4, **dadurch gekennzeichnet, dass** die beiden Wirbelgeneratoren der ersten Reihe (24) in einem Längsschnitt (28) des Windenergieanlagenrotorblatts angeordnet sind, in dem das Windenergieanlagenrotorblatt ein aerodynamisches Profil mit einer relativen Dicke von 0,35 oder mehr aufweist.

6. Windenergieanlagenrotorblatt (10) nach einem der Ansprüche 1 bis 5, **dadurch gekennzeichnet, dass** das aerodynamische Profil eine flache Hinterkante (22) aufweist.

7. Windenergieanlagenrotorblatt (10) nach einem der Ansprüche 1 bis 6, **dadurch gekennzeichnet, dass** die flache Hinterkante (22) eine Dicke von mindestens 2 % einer Sehnenlänge (72) des aerodynamischen Profils aufweist.

8. Windenergieanlagenrotorblatt (10) nach einem der Ansprüche 1 bis 7, **dadurch gekennzeichnet, dass** ein Wirbelgenerator der ersten Reihe (24) eine auf einer Oberfläche des Windenergieanlagenrotorblatts montierte Grundplatte (64) aufweist, wobei die beiden ersten Finnen (30, 42) des Wirbelgenerators mit der Grundplatte (64) verbunden sind.

9. Windenergieanlagenrotorblatt (10) nach einem der Ansprüche 1 bis 8, **dadurch gekennzeichnet, dass** ein Wirbelgenerator der zweiten Reihe (26) eine auf einer Oberfläche des Windenergieanlagenrotorblatts montierte Grundplatte (66) aufweist, wobei eine einzelne zweite Finne (32) mit der Grundplatte (66) verbunden ist.

Revendications

1. Pale de rotor d'éolienne (10) comportant un pied de pale (12), une extrémité de pale (14), un bord d'attaque (20), un bord de fuite (22), une première rangée (24) de générateurs de vortex et une seconde rangée (26) de générateurs de vortex,

- dans laquelle la première rangée (24) et la seconde rangée (26) s'étendent dans une direction généralement dans le sens de l'envergure et la première rangée (24) est agencée plus près du bord d'attaque (20) que la seconde rangée (26),

- dans laquelle la première rangée (24) comporte deux générateurs de vortex adjacents, ayant chacun un axe longitudinal (44, 50) s'étendant dans une direction généralement dans le sens de la corde, et deux premières ailettes (30, 42, 46, 48) agencées symétriquement à l'axe longitudinal (44, 50), dans laquelle chacune des deux premières ailettes (30, 42, 46, 48) a une extrémité d'attaque (34) et une extrémité de fuite (36), dans laquelle les extrémités de fuite (36) sont agencées à une distance d l'une de l'autre, dans laquelle la distance d est supérieure à une distance entre les extrémités d'attaque (34), dans laquelle les deux axes longitudinaux (44, 50) sont agencés à une distance D l'un de l'autre et définissent une ligne centrale (52) s'étendant dans une direction généralement dans le sens de la corde,

- dans laquelle la seconde rangée (24) de générateurs de vortex comporte une seconde ailette (32) ayant une extrémité d'attaque (38) et une extrémité de fuite (40), dans laquelle l'extrémité de fuite (40) est agencée plus près de la ligne centrale (52) que l'extrémité d'attaque (38),

- dans laquelle la seconde ailette (32) est positionnée par rapport à la première ailette (30) qui est agencée du même côté de la ligne centrale (52) que la seconde ailette (32) et avec son extrémité de fuite (40) plus proche de la ligne centrale (52) que son extrémité d'attaque (38), de sorte que l'extrémité de fuite (40) de la seconde ailette (32) soit agencée à une distance c dans le sens de la corde à partir de l'extrémité de fuite (36) de cette première ailette (30), **caractérisée en ce que**

- la distance c dans le sens de la corde est supérieure à deux fois la distance d et
- une distance x entre l'extrémité de fuite (40) de la seconde ailette (32) et la ligne centrale (52) se trouve au sein de la plage entre

(i) une limite supérieure x_U définie par :

$$x_U \leq 0,30 D \quad \text{pour } c > 1,43 D - 3,57 d$$

$$x_U \leq D/2 - d/2 - 0,14 c \quad \text{pour } c \leq 1,43 D - 3,57 d \text{ et}$$

(ii) une limite inférieure x_L définie par

$$x_L \geq 0,07 D \quad \text{pour } c > 0,75 D - 0,87 d$$

$$x_L \geq D/2 - d/2 - 0,58 c \quad \text{pour } c \leq 0,75 D - 0,87 d.$$

2. Pale de rotor d'éolienne (10) selon la revendication 1, **caractérisée en ce que** la limite supérieure x_U est définie par

$$x_U \leq 0,18 D \quad \text{pour } c > 1,19 D - 1,87 d$$

$$x_U \leq D/2 - d/2 - 0,27 c \quad \text{pour } c \leq 1,19 D - 1,87 d.$$

3. Pale de rotor d'éolienne (10) selon la revendication 1 ou 2, **caractérisée en ce que** la limite inférieure x_L est définie par

$$x_L \geq 0,10 D \quad \text{pour } c > 0,85 D - 1,06 d$$

$$x_L \geq D/2 - d/2 - 0,47 c \quad \text{pour } c \leq 0,85 D - 1,06 d.$$

4. Pale de rotor d'éolienne (10) selon l'une quelconque des revendications 1 à 3, **caractérisée en ce que** la seconde rangée (26) comporte une pluralité de secondes ailettes (32), dans laquelle chacune des secondes ailettes (32) est agencée par rapport à l'une des premières ailettes (30, 42, 46, 48) selon la revendication 1.

EP 4 027 006 B1

5. Pale de rotor d'éolienne (10) selon l'une quelconque des revendications 1 à 4, **caractérisée en ce que** les deux générateurs de vortex de la première rangée (24) sont agencés dans une section longitudinale (28) de la pale de rotor d'éolienne dans laquelle la pale de rotor d'éolienne (10) a un profil aérodynamique avec une épaisseur relative de 0,35 ou plus.

5
6. Pale de rotor d'éolienne (10) selon l'une quelconque des revendications 1 à 5, **caractérisée en ce que** le profil aérodynamique a un bord de fuite plat (22).

10
7. Pale de rotor d'éolienne (10) selon l'une quelconque des revendications 1 à 6, **caractérisée en ce que** le bord de fuite plat (22) a une épaisseur d'au moins 2 % d'une longueur de corde (72) du profil aérodynamique.

15
8. Pale de rotor d'éolienne (10) selon l'une quelconque des revendications 1 à 7, **caractérisée en ce qu'**un générateur de vortex de la première rangée (24) comporte une plaque de base (64) montée sur une surface de pale de rotor d'éolienne, dans laquelle les deux premières ailettes (30, 42) du générateur de vortex sont reliées à la plaque de base (64).

20
9. Pale de rotor d'éolienne (10) selon l'une quelconque des revendications 1 à 8, **caractérisée en ce qu'**un générateur de vortex de la seconde rangée (26) comporte une plaque de base (66) montée sur une surface de pale de rotor d'éolienne, dans laquelle une seconde ailette unique (32) est reliée à la plaque de base (66).

25

30

35

40

45

50

55

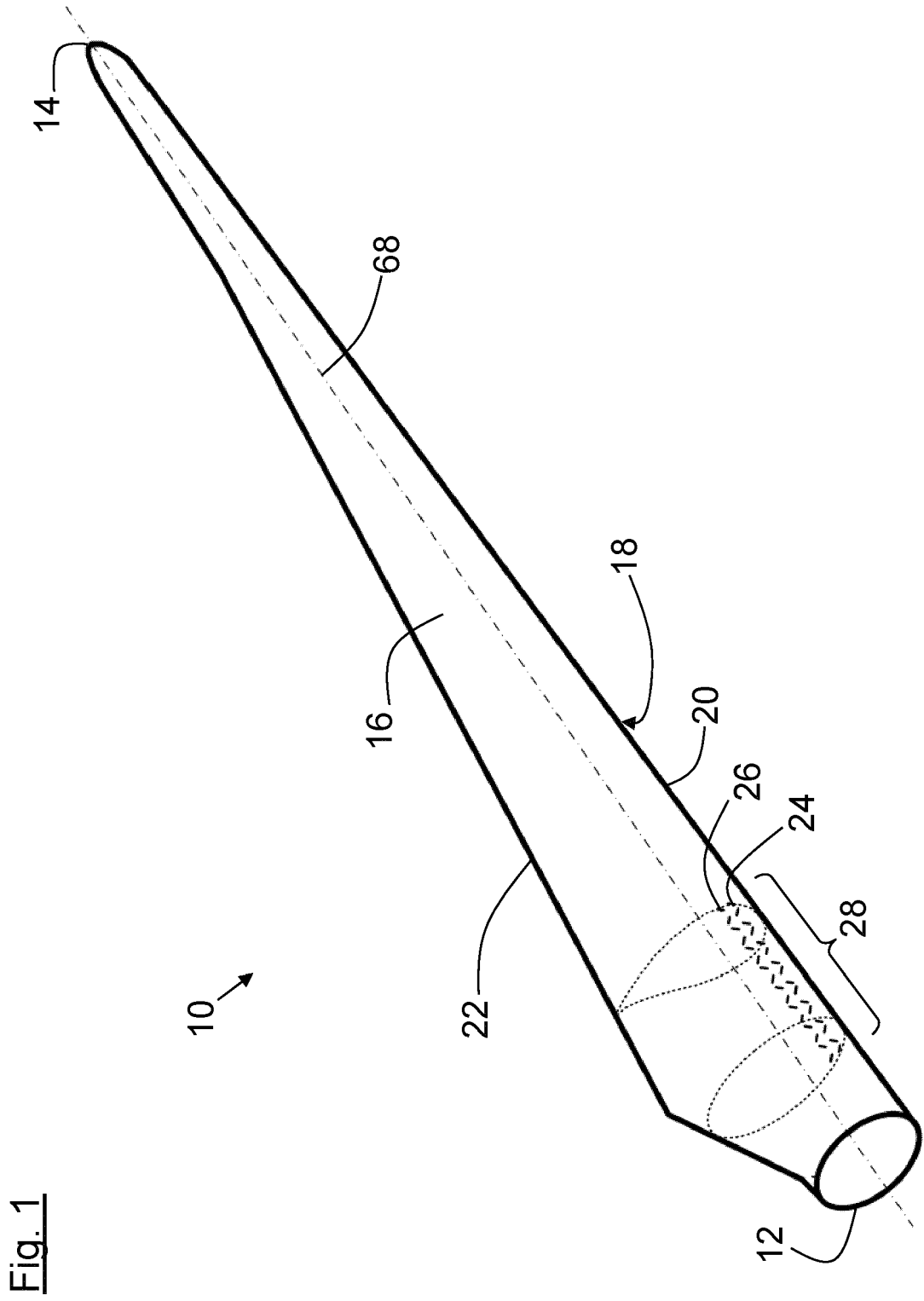
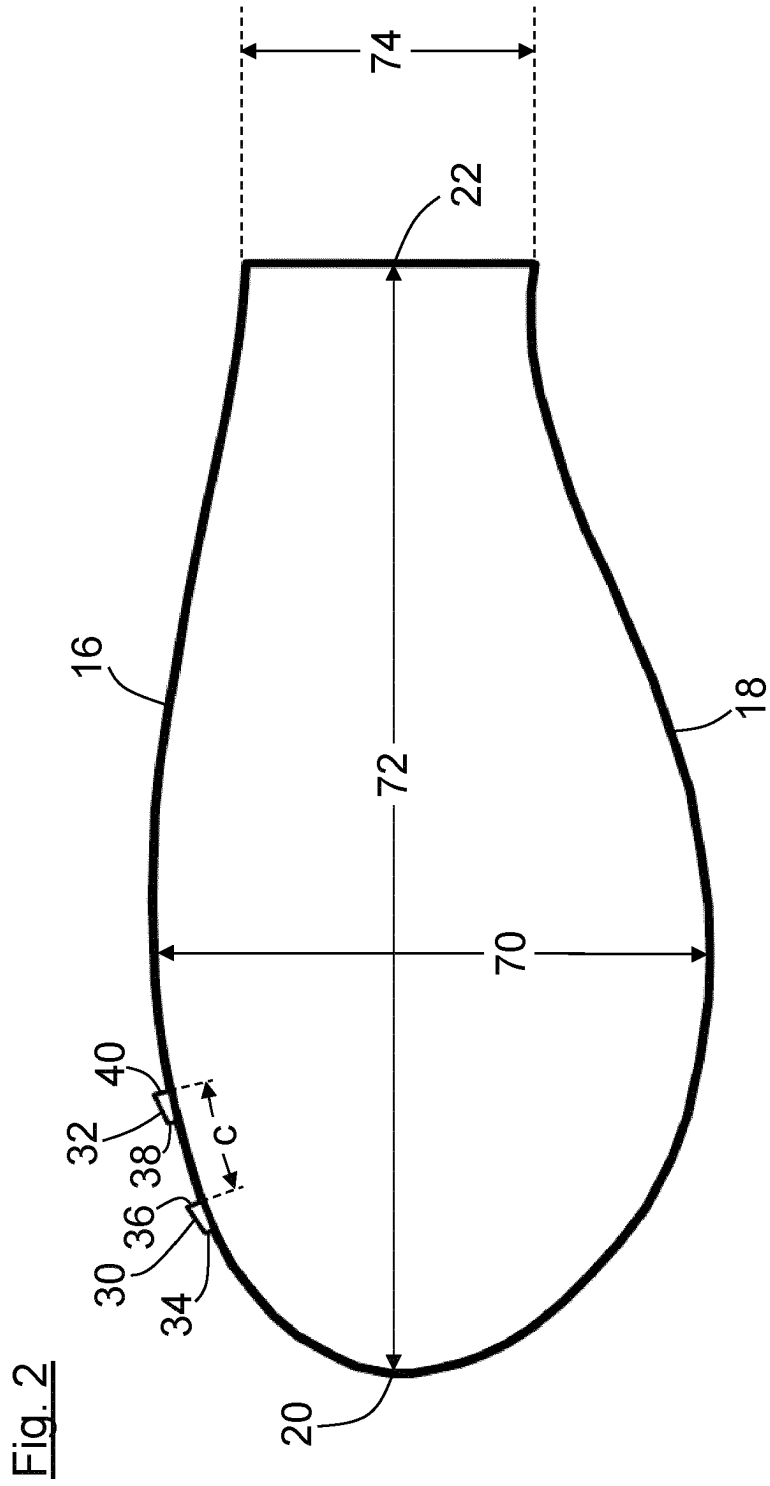

Fig. 1



REFERENCES CITED IN THE DESCRIPTION

This list of references cited by the applicant is for the reader's convenience only. It does not form part of the European patent document. Even though great care has been taken in compiling the references, errors or omissions cannot be excluded and the EPO disclaims all liability in this regard.

Patent documents cited in the description

- EP 3037565 B1 [0004]
- EP 2129908 B1 [0005]
- US 20110229321 A1 [0006]