

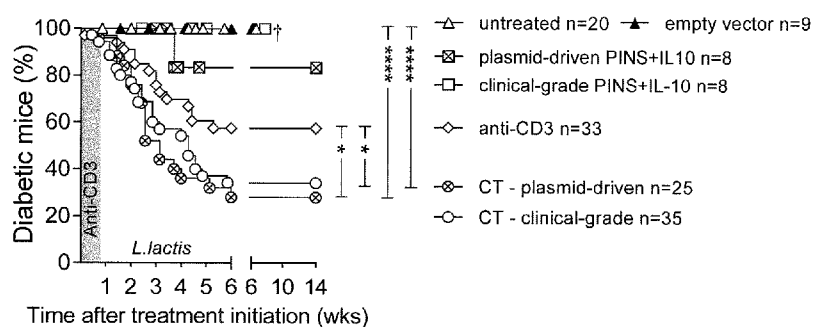

- (51) International Patent Classification:
A61K 39/008 (2006.01) C12N 15/74 (2006.01)
A61K 35/744 (2015.01)
- (21) International Application Number:
PCT/IB2017/055287
- (22) International Filing Date:
02 September 2017 (02.09.2017)
- (25) Filing Language: English
- (26) Publication Language: English
- (30) Priority Data:
62/383,079 02 September 2016 (02.09.2016) US
- (71) Applicant: INTREXON ACTOBIOTICS N.V. [BE/BE];
Technologiepark 4, B-9052 Zwijnaarde (BE).
- (72) Inventors: ROTTIERS, Pieter; Twee Dreven 37, B-9840 De Pinte (BE). STEIDLER, Lothar; Bokslaarstraat 41, B-9160 Lokeren (BE).
- (81) Designated States (unless otherwise indicated, for every kind of national protection available): AE, AG, AL, AM, AO, AT, AU, AZ, BA, BB, BG, BH, BN, BR, BW, BY, BZ, CA, CH, CL, CN, CO, CR, CU, CZ, DE, DJ, DK, DM, DO, DZ, EC, EE, EG, ES, FI, GB, GD, GE, GH, GM, GT, HN, HR, HU, ID, IL, IN, IR, IS, JO, JP, KE, KG, KH, KN, KP, KR, KW, KZ, LA, LC, LK, LR, LS, LU, LY, MA, MD, ME, MG, MK, MN, MW, MX, MY, MZ, NA, NG, NI, NO, NZ, OM, PA, PE, PG, PH, PL, PT, QA, RO, RS, RU, RW, SA, SC, SD, SE, SG, SK, SL, SM, ST, SV, SY, TH, TJ, TM, TN, TR, TT, TZ, UA, UG, US, UZ, VC, VN, ZA, ZM, ZW.
- (84) Designated States (unless otherwise indicated, for every kind of regional protection available): ARIPO (BW, GH, GM, KE, LR, LS, MW, MZ, NA, RW, SD, SL, ST, SZ, TZ,

(54) Title: GENETICALLY MODIFIED BACTERIA STABLY EXPRESSING IL-10 AND INSULIN

Figure 1A



(57) Abstract: The current disclosure provides microorganisms, such as lactic acid bacteria (e.g., *Lactococcus lactis*) containing an exogenous nucleic acid encoding an IL-10 polypeptide and an exogenous nucleic acid encoding a T1D-specific antigen (e.g., a proinsulin) polypeptide, wherein both exogenous nucleic acids are integrated into the bacterial chromosome. Such microbial strains are suitable for human therapy. The disclosure further provides compositions (e.g., pharmaceutical compositions) methods of using the microorganisms and compositions, e.g., for the treatment of type 1 diabetes (T1D), including those with residual beta-cell function, e.g., recent-onset T1D. The microorganism may be administered orally, delivers the microorganism into the gastrointestinal tract, where it is released and expresses the bioactive polypeptides, The methods of the present disclosure are particularly well suited for subjects possessing residual beta-cell function, e.g., for subjects with recent-onset T1D.

UG, ZM, ZW), Eurasian (AM, AZ, BY, KG, KZ, RU, TJ, TM), European (AL, AT, BE, BG, CH, CY, CZ, DE, DK, EE, ES, FI, FR, GB, GR, HR, HU, IE, IS, IT, LT, LU, LV, MC, MK, MT, NL, NO, PL, PT, RO, RS, SE, SI, SK, SM, TR), OAPI (BF, BJ, CF, CG, CI, CM, GA, GN, GQ, GW, KM, ML, MR, NE, SN, TD, TG).

Published:

- *with international search report (Art. 21(3))*
- *with sequence listing part of description (Rule 5.2(a))*

GENETICALLY MODIFIED BACTERIA STABLY EXPRESSING IL-10 AND INSULIN

CROSS REFERENCE TO RELATED APPLICATION

[001] This application claims the benefit of the filing date of U.S. Provisional Patent
5 Application No. 62/383,079, filed September 2, 2016.

REFERENCE TO SEQUENCE LISTING

[002] This application contains a Sequence Listing which has been submitted
electronically in ASCII format and is hereby incorporated by reference in its entirety. Said
ASCII copy, created on August 30, 2017, is named 205350_0032_WO_567020_ST25.txt and
10 is 43,027 bytes in size.

BACKGROUND

[003] Genetically modified microorganisms (*e.g.*, bacteria) have been used to deliver
therapeutic molecules to mucosal tissues. *See, e.g.*, Steidler, L., *et al.*, *Nat. Biotechnol.* 2003,
21(7): 785-789; and Robert S. and Steidler L., *Microb. Cell Fact.* 2014, 13 Suppl. 1: S11.

15 [004] Interleukin 10 (IL-10) producing lactic acid bacteria have been previously
described and mucosally administered IL-10 and/or insulin or proinsulin have been described
for the treatment of type-1 diabetes (T1D). *See e.g.*, International patent application
publication WO 2007/063075; Robert S. *et al.*, *Diabetes* 2014, 63: 2876-2887; Steidler *et al.*,
Nat. Biotechnol. 2003, 21(7): 785-789; and Takiishi T. *et al.*, *J. Clin. Invest.* 2012, 122(5):
20 1717-1725.

[005] However, there is still a need in the art for genetically modified bacterial strains
that are stable, constitutively express more than one bioactive polypeptide and are suitable for
clinical usage, *e.g.*, for the treatment of T1D. The present disclosure addresses these needs.

SUMMARY

25 [006] The current disclosure provides genetically modified microorganisms containing
chromosomally integrated nucleic acids encoding IL-10 and proinsulin (PINS), methods of
preparing such microorganisms, and methods of using such microorganisms. These
genetically modified microorganisms can be suitable to human therapy, including but not
limited to the treatment of diabetes, *e.g.*, T1D.

Microorganisms and Compositions

[007] The present disclosure provides microorganisms, *e.g.*, Gram-positive bacteria, such as a lactic acid bacterium (LAB) containing an exogenous nucleic acid encoding an interleukin-10 (IL-10) polypeptide, and an exogenous nucleic acid encoding a T1D-specific antigen, such as proinsulin (PINS) polypeptide, wherein the exogenous nucleic acid encoding the IL-10 polypeptide and the exogenous nucleic acid encoding the T1D-specific antigen (*e.g.*, PINS polypeptide) are both chromosomally integrated, *i.e.*, are integrated into (or located on) the bacterial chromosome.

[008] The microorganism can be a Gram-positive bacterium, such as an LAB. The LAB can be a *Lactococcus* species bacterium. In other embodiments, the LAB is a *Lactobacillus* species, or a *Bifidobacterium* species. In some embodiments, the LAB can be *Lactococcus lactis*. The LAB can be *Lactococcus lactis* subspecies *cremoris*. Another exemplary LAB is a *Lactococcus lactis* strain MG1363. *See, e.g.*, Gasson, M.J., *J. Bacteriol.* 1983, 154: 1-9.

[009] In some examples according to any of the above embodiments, the IL-10 polypeptide is human IL-10 (hIL-10). In other examples, the IL-10 is an IL-10 variant polypeptide, *e.g.*, including at least one point mutation, *e.g.*, to increase expression of the IL-10 polypeptide by the bacterium. In some examples according to these embodiments the IL-10 is "mature" human IL-10 (hIL-10), *i.e.* without its signal peptide. In some embodiments, the hIL-10 comprises a proline (Pro) to alanine (Ala) substitution, at position 2, when counting the amino acids in the mature peptide. *See, e.g.*, SEQ ID NO: 1. Such polypeptides are described, *e.g.*, in Steidler *et al.*, *Nat. Biotechnol.* 2003, 21(7): 785-789, the disclosure of which incorporated herein by reference in its entirety. In some examples, the IL-10 polypeptide is wild-type human IL-10. In other examples, the IL-10 polypeptide is wild-type human IL-10 without its own signal peptide and has an amino acid sequence at least 90%, at least 92%, at least 95%, at least 96%, at least 97%, at least 98%, or at least 99% identical to SEQ ID NO: 1. In other examples, the exogenous nucleic acid encoding the IL-10 polypeptide has a nucleotide sequence at least 90%, at least 92%, at least 95%, at least 96%, at least 97%, at least 98%, or at least 99% identical to SEQ ID NO: 2.

[0010] In some examples according to any of the above embodiments, the T1D-specific antigen polypeptide is a PINS polypeptide, such as human PINS (hPINS), *e.g.*, wild-type human PINS. In some examples, the PINS polypeptide has an amino acid sequence at least 90%, at least 92%, at least 95%, at least 96%, at least 97%, at least 98%, or at least 99% identical to SEQ ID NO: 5. The wild-type PINS may be encoded by a nucleotide sequence

that is at least 90%, at least 92%, at least 95%, at least 96%, at least 97%, at least 98%, or at least 99% identical to SEQ ID NO: 6 or SEQ ID NO: 7. In other examples, the PINS polypeptide is human PINS without its signal peptide and has an amino acid sequence that is at least 90%, at least 92%, at least 95%, at least 96%, at least 97%, at least 98%, or at least 99% identical to SEQ ID NO: 3. In other examples, the exogenous nucleic acid encoding the PINS polypeptide has a nucleotide sequence at least 90%, at least 92%, at least 95%, at least 96%, at least 97%, at least 98%, or at least 99% identical to SEQ ID NO: 4.

[0011] In some examples according to any of the above embodiments, the microorganism, (e.g., LAB) expresses (e.g., constitutively expresses) the IL-10 polypeptide. In other examples, the microorganism (e.g., LAB) constitutively expresses and secretes the IL-10 polypeptide (e.g., hIL-10). In other examples according to any of the above embodiments, the LAB constitutively expresses the T1D-specific antigen polypeptide (e.g., PINS polypeptide). In other examples, the microorganism (e.g., LAB) constitutively expresses and secretes the T1D-specific antigen (e.g., PINS) polypeptide. In yet other examples, the microorganism (e.g., LAB) constitutively expresses and secretes the IL-10 polypeptide (e.g., hIL-10) and the T1D-specific antigen (e.g., PINS) polypeptide (e.g., hPINS).

[0012] In some examples according to any of the above embodiments, the exogenous nucleic acid encoding the IL-10 polypeptide is positioned 3' of an *hllA* promoter (*PhllA*), such as a *Lactococcus lactis PhllA*. In some examples according to this embodiment, the exogenous nucleic acid encoding the IL-10 polypeptide is transcriptionally regulated by the *PhllA*. In other examples, the LAB includes an IL-10 expression cassette containing a *PhllA* promoter (e.g., a *Lactococcus lactis PhllA*), an IL-10 secretion sequence (e.g., positioned 3' of the *PhllA*), and the exogenous nucleic acid encoding the IL-10 polypeptide (e.g., positioned 3' of the IL-10 secretion sequence). In some examples, the IL-10 expression cassette is chromosomally integrated. In some examples, the IL-10 expression cassette is chromosomally integrated thereby replacing or partially replacing another gene. In some examples according to this embodiment, the IL-10 expression cassette is chromosomally integrated at the *thyA* locus, e.g., replacing an endogenous *thyA* gene, e.g., as described in Steidler *et al.*, *Nat. Biotechnol.* 2003, 21(7): 785-789. In some examples according to any of the above embodiments, the IL-10 secretion sequence is a nucleotide sequence encoding a secretion leader of unidentified secreted 45-kDa protein (Usp45). Such secretion sequence is referred to herein as SSusp45. In some examples, SSusp45 has an amino acid sequence that is

at least 90%, at least 92%, at least 95%, at least 96%, at least 97%, at least 98%, or at least 99% identical to SEQ ID NO: 10. In other examples, SSusp45 is encoded by a nucleic acid sequence that is at least 90%, at least 92%, at least 95%, at least 96%, at least 97%, at least 98%, or at least 99% identical to SEQ ID NO: 11 or SEQ ID NO: 12. In some examples
5 SSusp45 in the IL-10 expression cassette is encoded by a nucleic acid sequence that is at least 90%, at least 92%, at least 95%, at least 96%, at least 97%, at least 98%, or at least 99% identical to SEQ ID NO: 11. In some examples, the IL-10 expression cassette is illustrated by: *PhIIA*>>SSusp45>>hIL-10. The nucleotide sequence of an exemplary IL-10 expression cassette is depicted in Figure 11.

10 **[0013]** In some examples according to any of the above embodiments, the exogenous nucleic acid encoding the T1D-specific antigen (*e.g.*, PINS) polypeptide is positioned 3' of a *gapB* promoter, *e.g.*, a *gapB* promoter that is endogenous to the microorganism (*e.g.*, LAB). In other examples according to this embodiment, the exogenous nucleic acid encoding the T1D-specific antigen (*e.g.*, PINS) polypeptide is transcriptionally regulated by the *gapB*
15 promoter. In other examples, the exogenous nucleic acid encoding the T1D-specific antigen (*e.g.*, PINS) polypeptide is positioned 3' of a *gapB* gene (*gapB*) and its *gapB* promoter. In other examples, the LAB comprises a first polycistronic expression cassette (*e.g.*, a dual cistron) comprising a *gapB* promoter positioned 5' of a *gapB* gene, a T1D-specific antigen secretion sequence (*e.g.*, PINS secretion sequence) (*e.g.*, positioned 3' of the *gapB*), and the
20 exogenous nucleic acid encoding the T1D-specific antigen (*e.g.*, PINS) polypeptide (*e.g.*, 3' of the PINS secretion sequence). In some examples according to this embodiment, the polycistronic expression cassette further includes an intergenic region, *e.g.*, between the *gapB* and the PINS secretion sequence. In some examples according to any of the above embodiments, the *gapB* promoter and the *gapB* gene are endogenous to the microorganism
25 (*e.g.*, LAB). In some examples, the PINS secretion sequence is SSusp45. In other examples according to the above embodiments, the first polycistronic expression cassette is chromosomally integrated. In other examples, the first polycistronic expression cassette is illustrated by: P*gapB*>>*gapB*>>intergenic region>>SSusp45>>PINS. In some examples according to any of the above embodiments, the intergenic region in the first polycistronic
30 expression cassette is *rpmD* gene 5' intergenic region (*i.e.* the region preceding *rpmD*). In some examples according to any of the above embodiments, the *rpmD* has a nucleotide sequence according to SEQ ID NO: 8 (which includes a stop codon of the first gene, and a

start codon of a second gene). Without the start and stop codons, the intergenic region *rpmD* has a nucleic acid sequence according to SEQ ID NO: 9.

[0014] In some examples according to any of the above embodiments, the microorganism (*e.g.*, LAB) further comprises an exogenous nucleic acid encoding a trehalose-6-phosphate phosphatase, *e.g.*, *otsB*, such as *Escherichia coli otsB*. In some examples according to these 5 embodiments, the exogenous nucleic acid encoding the trehalose-6-phosphate phosphatase is chromosomally integrated. In some examples, the exogenous nucleic acid encoding the trehalose-6-phosphate phosphatase is chromosomally integrated 3' of unidentified secreted 45-kDa protein gene (*usp45*). In some examples according to this embodiment, the LAB 10 comprises a second polycistronic expression cassette comprising a *usp45* promoter, the *usp45* gene (*e.g.*, 3' of the promoter), and the exogenous nucleic acid encoding a trehalose-6-phosphate phosphatase (*e.g.*, 3' of the *usp45* gene). In some examples, the second polycistronic expression cassette further comprises an intergenic region between the *usp45* gene and the exogenous nucleic acid encoding a trehalose-6-phosphate phosphatase. In some 15 examples, the second polycistronic expression cassette is illustrated by: Pusp45>>usp45>>intergenic region>>*otsB*. In some examples according to these embodiments, the intergenic region is *rpmD* as described herein above (*e.g.*, having SEQ ID NO: 8 or SEQ ID NO: 9). The second polycistronic expression cassette may then be illustrated by: Pusp45>>usp45>>*rpmD*>>*otsB*.

20 [0015] In some examples according to any of the above embodiments, a trehalose-6-phosphate phosphorylase gene (*trePP*) is disrupted or inactivated in the microorganism (*e.g.*, LAB). For example, the *trePP* has been inactivated by removing the *trePP* gene or a fragment thereof, or the *trePP* has been disrupted by inserting a stop codon. Thus, in some examples according to these embodiments, the microorganism (*e.g.*, LAB) lacks *trePP* 25 activity.

[0016] In other examples according to any of the above embodiments, a cellobiose-specific PTS system IIC component gene (*ptcC*) has been disrupted or inactivated in the microorganism (*e.g.*, LAB). For example, the *ptcC* has been disrupted by inserting a stop codon, or *ptcC* has been inactivated by removing the *ptcC* or a fragment thereof. Thus, in 30 some examples according to these embodiments, the microorganism (*e.g.*, LAB) lacks *ptcC* activity.

[0017] In other examples according to any of the above embodiments, the LAB further comprises one or more genes encoding one or more trehalose transporter(s). In some

examples, the one or more genes encoding the one or more trehalose transporter(s) are endogenous to the LAB. In some examples, the LAB overexpresses the one or more genes encoding the one or more trehalose transporter(s). In some examples according to these embodiments, the one or more genes encoding the one or more trehalose transporter(s) is positioned 3' of an exogenous promoter, *e.g.*, an *hllA* promoter (*PhllA*). For example, the one or more genes encoding the one or more trehalose transporter(s) are transcriptionally regulated by the *PhllA*. In some examples according to these embodiments, the one or more genes encoding the one or more trehalose transporter(s) is selected from *llmg_0453*, *llmg_0454*, and any combination thereof. In some examples, *llmg_0453* and *llmg_0454* are transcriptionally regulated by a *PhllA*.

[0018] In some examples, according to any of the above embodiments, the one or more genes encoding one or more trehalose transporter(s) comprises two genes encoding two trehalose transporters, wherein an intergenic region is located between the two genes. In some examples, the intergenic region is *rpmD*, *e.g.*, having SEQ ID NO: 8 or SEQ ID NO: 9. In some examples, the microorganism (*e.g.*, LAB) comprises a polycistronic expression cassette comprising two nucleic acid sequences (*e.g.*, genes) encoding two different trehalose transporters (transporter 1 and transporter 2 sequences) and an intergenic region between the two nucleic acids encoding the two different trehalose transporters. Such expression cassette may be illustrated by: *PhllA*>>transporter 1>>intergenic region>>transporter 2. In some examples according to these embodiments, the intergenic region is *rpmD* as described herein above (*e.g.*, having SEQ ID NO: 8 or SEQ ID NO: 9). The polycistronic expression cassette may then be illustrated by: *PhllA*>>transporter1>> *rpmD* >>transporter2.

[0019] Thus, in some embodiments, the LAB comprises, in a single strain, several useful features. In one embodiment, the LAB is *Lactococcus lactis*, comprising:

- (A) a chromosomally integrated promoter>>secretion signal>> therapeutic protein, such as an interleukin, antigen, or enzyme;
- (B) a chromosomally-integrated promoter >> secretion signal>>optional second therapeutic protein.
- (C) a combination of mutations and insertions to promote trehalose accumulation, which enhances LAB survivability against bile salts and drying. The mutations are selected from

- (i) chromosomally-integrated trehalose transporter(s), such as *PhlIA*>>transporter 1>> intergenic region>>transporter 2, such as *llmg_0453* and/or *llmg_0454*, for uptake of trehalose;
- (ii) chromosomally-integrated Trehalose-6-phosphate phosphatase gene (*otsB*; Gene ID: 1036914) positioned downstream of *usp45* (Gene ID: 4797218) to facilitate conversion of trehalose-6-phosphate to trehalose;
- (iii) inactivated (*e.g.* through gene deletion) Trehalose-6-phosphate phosphorylase gene (*trePP*; Gene ID: 4797140); and
- (iv) inactivated cellobiose-specific PTS system IIC component (Gene ID: 4796893), *ptcC*, (*e.g.* *tga* at codon position 30 of 446; *tga30*).

The LAB may also contain an auxotrophic mutation for biological containment, such as *thyA*.

[0020] In one embodiment, the LAB is *Lactococcus lactis*, comprising:

- (A) a chromosomally integrated promoter>>secretion signal>>hIL-10 to secrete mature hIL-10 from LAB, such as *PhlIA*>>SSusp45>>hIL-10;
- (B) a chromosomally-integrated promoter >> secretion signal>>PINS, to secrete mature PINS from LAB; such as *PgapB*>>*gapB*>>intergenic region>>SSusp45>>PINS. The intergenic region could be, for example, *rpmD*;
- (C) a combination of mutations and insertions to promote trehalose accumulation, which enhances LAB survivability against bile salts and drying. The mutations are selected from
 - (i) chromosomally-integrated trehalose transporter(s), such as *PhlIA*>>transporter 1>> intergenic region>>transporter 2, such as *llmg_0453* and/or *llmg_0454*, for uptake of trehalose;
 - (ii) chromosomally-integrated Trehalose-6-phosphate phosphatase gene (*otsB*; Gene ID: 1036914) positioned downstream of *usp45* (Gene ID: 4797218) to facilitate conversion of trehalose-6-phosphate to trehalose;
 - (iii) inactivated (*e.g.* through gene deletion) Trehalose-6-phosphate phosphorylase gene (*trePP*; Gene ID: 4797140); and
 - (iv) inactivated cellobiose-specific PTS system IIC component (Gene ID: 4796893), *ptcC*, (*e.g.* *tga* at codon position 30 of 446; *tga30*).

The LAB may also contain an auxotrophic mutation for biological containment, such as *thyA*.

[0021] In one embodiment, the LAB is *Lactococcus lactis*, with

- (A) *thyA* mutation, for biological containment
- (B) a chromosomally integrated *PhlIA*>>SSusp45>>hIL-10 to secrete mature hIL-10 from
5 LAB;
- (C) a chromosomally-integrated *PgapB*>>*gapB*>>intergenic region>>SSusp45>>PINS,
wherein the intergenic region is selected from *rpmD*, to secrete mature PINS from
LAB;
- (D) chromosomally-integrated trehalose transporter(s), such as *PhlIA*>>transporter 1>>
10 intergenic region>>transporter 2, such as *llmg_0453* and/or *llmg_0454*, for uptake of
trehalose;
- (E) inactivated (*e.g.* through gene deletion) Trehalose-6-phosphate phosphorylase gene
(*trePP*; Gene ID: 4797140);
- (F) chromosomally integrated Trehalose-6-phosphate phosphatase gene (*otsB*; Gene ID:
15 1036914) (positioned downstream of *usp45* (Gene ID: 4797218) to facilitate
conversion of trehalose-6-phosphate to trehalose; and
- (G) inactivated cellobiose-specific PTS system IIC component (Gene ID: 4796893), *ptcC*,
(*e.g.* *tga* at codon position 30 of 446; *tga30*).

[0022] The present disclosure further provides compositions containing a microorganism
20 (*e.g.*, an LAB) as described herein, *e.g.*, a microorganism (*e.g.*, LAB) in accordance with any
of the above embodiments.

[0023] The present disclosure further provides pharmaceutical compositions containing a
microorganism (*e.g.*, LAB) as described herein, *e.g.*, a microorganism (*e.g.*, LAB) in
accordance with any of the above embodiments, and further containing a pharmaceutically
25 acceptable carrier.

[0024] The present disclosure further provides a microbial suspension (*e.g.*, bacterial
suspension) containing a microorganism (*e.g.*, LAB) in accordance with any of the above
embodiments, and further containing a solvent, and a stabilizing agent. In some examples
according to this embodiment, the solvent is selected from water, oil, and any combination
30 thereof. For example, the present disclosure provides a bacterial suspension containing an
LAB of the present disclosure, an aqueous mixture (*e.g.*, a drink), and a stabilizing agent.

Exemplary stabilizing agents are selected from a protein or polypeptide (*e.g.*, glycoprotein), a peptide, a mono-, di- or polysaccharide, an amino acid, a gel, a fatty acid, a polyol (*e.g.*, sorbitol, mannitol, or inositol), a salt (*e.g.*, an amino acid salt), or any combination thereof.

[0025] The present disclosure further provides a microorganism as described herein (*e.g.*,
5 an LAB in accordance with any of the above embodiments), a composition as described herein, or a pharmaceutical composition as described herein, for use in the treatment of type-1 diabetes (T1D).

[0026] The present disclosure further provides a microorganism as described herein (*e.g.*,
10 an LAB in accordance with any of the above embodiments), a composition as described herein, or a pharmaceutical composition as described herein, for use in the preparation of a medicament, *e.g.*, for the treatment of a disease, *e.g.*, an autoimmune disease, such as type-1 diabetes (T1D)

Method 1: Methods of treating disease

[0027] The present disclosure further provides methods for the treatment of T1D in a
15 subject in need thereof. Exemplary methods include administering to the subject a therapeutically effective amount of a microorganism (*e.g.*, LAB) as disclosed herein (*e.g.*, an LAB in accordance with any of the above embodiments), a composition as disclosed herein, or a pharmaceutical composition as disclosed herein. In some examples according to any of these embodiments, the subject is a human, *e.g.*, a human patient. In some examples
20 according to any of these embodiments, the method further comprises administering an immunomodulatory agent (*e.g.*, an anti-CD3 antibody) to the subject. For example, the immuno-modulatory agent (*e.g.*, anti-CD3 antibody) is administered to the subject using a co-therapeutic regimen, *i.e.*, the subject (*e.g.*, human) is concurrently treated with another immune-modulatory agent, such as an anti-CD3 antibody. Thus, in some examples, the
25 present disclosure provides a method for the treatment of T1D in a human subject in need thereof. Exemplary methods include administering to the human subject a therapeutically effective amount of an LAB as disclosed herein (*e.g.*, an LAB in accordance with any of the above embodiments), a composition as disclosed herein, or a pharmaceutical composition as disclosed herein, wherein the human subject is further administered an anti-CD3 antibody
30 (*e.g.*, is concurrently treated with an anti-CD3 antibody) or fragment thereof.

[0028] In some examples, the anti-CD3 antibody is a monoclonal antibody. In other examples, the anti-CD3 antibody is a humanized monoclonal antibody. In other examples,

the anti-CD3 antibody is otelexizumab or teplizumab. In some examples, when administered as a combination therapy with LAB, the anti-CD3 antibody is administered to the subject in a dose different from that normally used for monotherapy. The optimal dose of anti-CD3 for use in combination therapy may be determined through animal models and clinical trials.

5 Preferably, the dose of anti-CD3 is less than a dose normally required for effective monotherapy with anti-CD3 antibody, *i.e.* a subtherapeutic dose. A dose effective for monotherapy may be determined by reference to animal models and clinical trials, and by the practice of those of skill in the art, and may be the regulatory-approved dose. In some examples, the subject undergoing combination therapy with LAB is administered a dose of anti-CD3 that is

10 at least about 10%, at least about 20%, at least about 30%, at least about 40%, at least about 50%, at least about 60%, at least about 70%, at least about 80%, or at least about 90% less than the standard dose of anti-CD3 in monotherapy. In other examples, the dose of anti-CD3 administered in combination therapy is about 10-100% less, about 10-90% less, about 10-70% less, about 10-60% less, about 10-50% less, about 50-100% less, or about 20-50% less

15 than the dose of anti-CD3 in monotherapy. Experiments have shown that 6 daily doses of 48 or 64 mg of otelexizumab can suppress T-cell activity enough that, at 36 months, the treatment group retained 80% more beta cell function than placebo control. However, such a dose was associated with reactivation of latent Epstein-Barr infection. A 3.1 mg/day dose for 8 days did not preserve beta-cell function. Therefore, a treatment at least 10% less than 48

20 mg (*i.e.* 43 mg) would be considered “subtherapeutic.”

[0029] In some embodiments, the mammalian subject in the above methods, has recently been diagnosed with T1D (*i.e.*, has recent-onset T1D). In some examples according to these embodiments, the subject has been diagnosed with T1D within the previous 12 months, the previous 24 months, or the previous 36 months prior to administering the microorganism

25 (*e.g.*, LAB).

[0030] In some examples according to any of the embodiments of Method 1, the method further includes measuring a clinical marker (*e.g.*, an immune biomarker) in the subject, *e.g.*, the subject’s organ or blood. For example, the method may further include measuring a T1D-related antibody in the subject’s blood. In some examples, the method can further include

30 measuring insulin autoantibody (IAA) in the subject’s blood. In some examples, the amount of IAA in the subject’s blood is indicative of T1D disease progression, *e.g.*, whether the subject can be classified as having recent-onset T1D, and may be indicative of whether the subject will likely benefit from treatment. Thus, measuring IAA may occur prior to

administering the microorganism to the subject. In some examples, IAA positivity at disease onset is predictive of positive therapeutic outcome. However, measuring IAA may also be used to monitor and measure the outcome of the treatment, and may therefore be used during treatment (*e.g.*, throughout the treatment period in intervals) to monitor treatment efficacy or outcome and/or subsequent to the treatment period, *e.g.*, to monitor whether the subject maintains treatment results (*e.g.*, normoglycemia) after treatment has stopped. In some examples, decline of IAA positivity is indicative of a positive therapeutic outcome. In other examples, the method further includes measuring regulatory T cells in the subject. Regulatory T cells include Treg17, Tr1 Th3, CD8⁺CD28⁻, Qa-1 restricted T cells, CD4⁺Foxp3⁺CD25⁺and/or CD4⁺Foxp3⁺CD25⁻ T cells. Preferably, CD4⁺Foxp3⁺CD25⁺and/or CD4⁺Foxp3⁺CD25⁻ T cells. In other examples, the method further includes measuring an initial blood glucose concentration in the subject. In other examples, the method further includes measuring C-peptide levels in the subject.

[0031] In related embodiments, the invention is a method of increasing the activity of Treg cells to suppress the autoimmune response to beta cells and/or a T1D-associated antigen, preferably suppressing the autoimmune response to all T1D-associated antigens. In other embodiments, the invention is a method of substantially decreasing, preferably halting, the autoimmune response to beta cells and/or any T1D-associated antigen. Preferably, the substantial decrease in the autoimmune response leads to a substantial decrease or halting of the disease progress.

[0032] In some embodiments in any of the above methods, the microorganism (*e.g.*, LAB) is administered to the subject orally. For example, the microorganism (*e.g.*, LAB) is administered to the subject in the form of a pharmaceutical composition for oral administration (*e.g.*, a capsule, tablet, granule, or liquid) comprising the microorganism (*e.g.*, LAB) and a pharmaceutically acceptable carrier. In other examples, the microorganism (*e.g.*, LAB) is administered to the subject in the form of a food product, or is added to a food (*e.g.*, a drink). In other examples, the microorganism (*e.g.*, LAB) is administered to the subject in the form of a dietary supplement. In yet other examples, the microorganism (*e.g.*, LAB) is administered to the subject in the form of a suppository product. In some examples, the compositions of the present disclosure are adapted for mucosal delivery of the polypeptides, which are expressed by the microorganism (*e.g.*, LAB). For example, compositions may be formulated for efficient release in the gastro-intestinal tract (*e.g.*, gut) of the subject.

[0033] In accordance with any of the above embodiments, the present disclosure further provides methods for establishing tolerance to a T1D-specific antigen (*e.g.*, PINS) polypeptide in a subject in need thereof. Exemplary methods include administering to the subject a therapeutically effective amount of a microorganism (*e.g.*, LAB) as disclosed herein (5 *e.g.*, an LAB in accordance with any of the above embodiments), a composition as disclosed herein, or a pharmaceutical composition as disclosed herein. In some examples according to any of these embodiments, the subject is a human, *e.g.*, a human patient.

[0034] In accordance with any of the above embodiments, the present disclosure further provides methods for decreasing IAA in a subject in need thereof, or for increasing the number of CD4⁺Foxp3⁺ T cells in a subject in need thereof. Exemplary methods include administering to the subject a therapeutically effective amount of a microorganism (*e.g.*, LAB) as disclosed herein (*e.g.*, an LAB in accordance with any of the above embodiments), a composition as disclosed herein, or a pharmaceutical composition as disclosed herein. In some examples according to any of these embodiments, the subject is a human, *e.g.*, a human patient. (15

[0035] In some examples, administering a therapeutically effective amount of a microorganism (*e.g.*, LAB) of the current disclosure and an anti-CD3 antibody of the current disclosure to the subject (*e.g.*, in accordance with any of the above methods), reduces the amount of insulin the subject is (*i.e.*, must be) administered to control blood glucose levels or maintain a certain blood glucose level (*e.g.*, as recommended by a physician, or as generally regarded as safe). For example, administering a therapeutically effective amount of a microorganism (*e.g.*, LAB) of the current disclosure and an anti-CD3 antibody of the current disclosure to the subject (*e.g.*, in accordance with any of the above methods), reduces the amount of insulin required to control blood glucose levels or maintain a certain blood glucose level in a subject when compared to the amount of insulin required by a corresponding subject not being administered the microorganism (*e.g.*, LAB) and the anti-CD3 antibody, or when compared to the amount of insulin required by a corresponding subject treated with anti-CD3 antibody alone. (20 25

[0036] In other examples, administering a therapeutically effective amount of a microorganism (*e.g.*, LAB) of the current disclosure and an anti-CD3 antibody of the current disclosure to the subject (*e.g.*, in accordance with any of the above methods), preserves beta-cell function in a subject (*e.g.*, preserves the beta-cell function measured at the beginning of treatment) in a subject, *e.g.*, as measured using art recognized methods. Exemplary methods (30

for measuring beta-cell function (*e.g.*, using C-peptide levels) are also described herein. In some examples, beta-cell function in the subject is preserved for at least about 2 months, at least about 4 months, at least about 6 months, at least about 8 months, at least about 10 months, at least about 12 months, at least about 14 months, at least about 16 months, at least about 18 months, at least about 20 months, at least about 22 months, or at least about 24 months after administration of the microorganism (*e.g.*, LAB) and the anti-CD3 antibody began. In other examples, administering a therapeutically effective amount of a microorganism (*e.g.*, LAB) of the current disclosure and an anti-CD3 antibody of the current disclosure to the subject (*e.g.*, in accordance with any of the above methods), increases the time in which beta-cell function is preserved in the subject, when compared to the time in which beta-cell function is preserved in a corresponding subjects not being administered the microorganism (*e.g.*, LAB) and the anti-CD3 antibody, or when compared to a corresponding subject treated with anti-CD3 antibody alone.

[0037] In other examples, administering a therapeutically effective amount of a microorganism (*e.g.*, LAB) of the current disclosure and an anti-CD3 antibody of the current disclosure to the subject (*e.g.*, in accordance with any of the above methods), maintains normal glycemia in a subject, *e.g.*, as measured using art recognized methods. Blood glucose ranges correlating with normal glycemia are described herein. For example, normal glycemia in a human subject may be correlated with two consecutive fasting blood glucose measurements of 126 mg/dL or less. Exemplary methods for measuring blood glucose levels are known in the art and are described herein. In some examples, normal glycemia in the subject (undergoing treatment) is preserved for at least about 2 months, at least about 4 months, at least about 6 months, at least about 8 months, at least about 10 months, at least about 12 months, at least about 14 months, at least about 16 months, at least about 18 months, at least about 20 months, at least about 22 months, or at least about 24 months after administration of the microorganism (*e.g.*, LAB) and the anti-CD3 antibody began. In other examples, administering a therapeutically effective amount of a microorganism (*e.g.*, LAB) of the current disclosure and an anti-CD3 antibody of the current disclosure to the subject (*e.g.*, in accordance with any of the above methods), increases the time in which normal glycemia is maintained in the subject, when compared to the time normal glycemia is maintained in a corresponding subject not being administered the microorganism (*e.g.*, LAB) and the anti-CD3 antibody, or when compared to the time normal glycemia is maintained in a corresponding subject treated with anti-CD3 antibody alone.

[0038] In other examples, administering a therapeutically effective amount of a microorganism (*e.g.*, LAB) of the current disclosure and an anti-CD3 antibody of the current disclosure to the subject (*e.g.*, in accordance with any of the above methods), maintains a normal hemoglobin A1c (HbA1c) level in a subject, *e.g.*, as measured using art recognized methods. In some examples, normal HbA1c level in the subject (undergoing treatment) is maintained for at least about 2 months, at least about 4 months, at least about 6 months, at least about 8 months, at least about 10 months, at least about 12 months, at least about 14 months, at least about 16 months, at least about 18 months, at least about 20 months, at least about 22 months, or at least about 24 months after administration of the microorganism (*e.g.*, LAB) and the anti-CD3 antibody.

[0039] In an alternative embodiment, the therapeutic method of the invention ameliorates the disease, such that in treated subjects the degree and frequency of hyperglycemia is reduced compared with untreated subjects. Such reduction may be 10, 20, 30, 40, 50, 60, 70, 80 or 90% of the untreated subjects.

[0040] Untreated T1D develops over time and becomes progressively worse as beta cells in the pancreas are destroyed. Thus, as the present method can halt disease, it is advantageous to treat subjects as early as possible in the disease progression. Such markers of disease progression include, without limitation, glycemic index, insulin autoantibody (IAA) levels, fragment C levels, and insulinitis. Thus, in a related embodiment, the therapeutic method of the invention also includes measuring disease progression prior to therapy, and during therapy.

[0041] For example, a human subject may be categorized as having early onset T1D when any one of the following is measured in the subject: (1) two consecutive fasting blood glucose tests are equal to or greater than 126 mg/dL; (2) when any random blood glucose measurement is greater than 200 mg/dL; (3) a hemoglobin A1c (HbA1c) test that is equal to or greater than 6.5 percent (HbA1c is a blood test that gives a three month average of blood sugars); or (4) a two-hour oral glucose tolerance test with any value over 200 mg/dL, or combinations thereof. Thus, normal glycemia may be characterized by any of the following: (1) two consecutive fasting blood glucose tests are below 126 mg/dL, below 120 mg/dL, or below 100 mg/dL; (2) when any random blood glucose measurement is below 200 mg/dL, below 180 mg/dL, below 160 mg/dL, or below 140 mg/dL; (3) a hemoglobin A1c (HbA1c) test that is less than 6.5 percent, or less than 6%; or (4) a two-hour oral glucose tolerance test

with a value below 200 mg/dL, below 180 mg/dL, below 160 mg/dL, or below 140 mg/dL, or any combination thereof.

[0042] Once disease progression is substantially decreased (and preferably ceased, especially with regard to autoimmunity that underlies the pathogenic process), a subject may be further treated by methods to restore beta cell function. Thus in a further embodiment, the subject may be treated with a beta-cell transplant, and/or with drugs to cause the proliferation of endogenous beta cells. Because the method is able to reverse the autoimmunity that underlies T1D, the method is not limited to early onset diabetes. Once the beta-cell destroying autoimmunity is eliminated, beta cell function can be restored through transplantation, and/or by encouraging the growth and development of endogenous beta cells. Thus, the method can be applied to subjects with chronic diabetes.

[0043] In a further embodiment, the therapeutic method of the invention ameliorates disease progression, such that the rate of worsening is three quarters, half, one quarter or less that of the untreated disease. Such worsening may be assessed through glycemic index, insulin autoantibody (IAA) levels, fragment C levels, and insulinitis, for example.

[0044] In a further embodiment, the therapeutic method of the invention is given to prevent T1D, such as by administration prior to any clinical symptoms. Preferably, the subject is identified as having T1D risk factors, including family history, elevated (but not diabetic) sugar levels in blood and urine, and antibodies to T1D associated antigens, and by a progressive worsening of these markers over time.

Method 2: Method of preparing a genetically-modified organism for treatment of T1D

[0045] The current disclosure further provides methods for preparing a genetically modified microorganism (*e.g.*, an LAB as disclosed herein. Exemplary methods include (i) contacting a microorganism (*e.g.*, LAB) with an exogenous nucleic acid encoding an IL-10 polypeptide; and (ii) contacting the microorganism (*e.g.*, LAB) with an exogenous nucleic acid encoding a T1D-specific antigen (*e.g.*, PINS) polypeptide, wherein the exogenous nucleic acid encoding the IL-10 polypeptide and the exogenous nucleic acid encoding the T1D-specific antigen (*e.g.*, PINS) polypeptide are chromosomally integrated (*i.e.*, integrated into the chromosome of the microorganism, *e.g.*, LAB). When the nucleic acids are integrated into the microbial (*e.g.*, bacterial) genome, *e.g.* in the chromosome, the genetically modified microorganism (*e.g.*, LAB) is formed. The microorganism (*e.g.*, LAB) subjected to the genetic modification of the current method can be any microbial strain, *e.g.*, can be a wild-

type bacterial strain, or can be genetically modified prior to contacting it with the exogenous nucleic acid encoding the IL-10 polypeptide and the exogenous nucleic acid encoding the T1D-specific antigen (*e.g.*, PINS) polypeptide.

[0046] In some examples, the above methods employ homologous recombination to integrate the nucleic acids into the microbial (*e.g.*, bacterial) chromosome. Thus, in some examples in accordance with these embodiments, the exogenous nucleic acid encoding the IL-10 polypeptide and the exogenous nucleic acid encoding the T1D-specific antigen (*e.g.*, PINS) polypeptide are chromosomally integrated using homologous recombination (*e.g.*, employing one or more integration plasmid containing the respective nucleic acids). In some examples according to any of these embodiments, contacting the microorganism (*e.g.*, LAB) with an exogenous nucleic acid encoding the IL-10 polypeptide (*e.g.*, an integration plasmid containing the exogenous nucleic acid encoding the IL-10 polypeptide) occurs prior to contacting the LAB with an exogenous nucleic acid encoding the T1D-specific antigen (*e.g.*, PINS) polypeptide (*e.g.*, an integration plasmid containing the exogenous nucleic acid encoding the PINS polypeptide). In other examples according to any of these embodiments, contacting the microorganism (*e.g.*, LAB) with an exogenous nucleic acid encoding the IL-10 polypeptide (*e.g.*, an integration plasmid containing the exogenous nucleic acid encoding the IL-10 polypeptide) occurs subsequent to contacting the LAB with an exogenous nucleic acid encoding the T1D-specific antigen (*e.g.*, PINS) polypeptide (*e.g.*, an integration plasmid containing the exogenous nucleic acid encoding the PINS polypeptide). In yet other examples according to any of these embodiments, the microorganism (*e.g.*, LAB) is contacted concurrently with an exogenous nucleic acid encoding the IL-10 polypeptide (*e.g.*, an integration plasmid containing the exogenous nucleic acid encoding the IL-10 polypeptide) and an exogenous nucleic acid encoding the T1D-specific antigen (*e.g.*, PINS) polypeptide (*e.g.*, an integration plasmid containing an exogenous nucleic acid encoding a PINS polypeptide), or a exogenous nucleic acid encoding both hIL-10 and PINS.

[0047] In some examples according to any of these embodiments, the method further includes combining a culture of the genetically modified microorganism (*e.g.*, LAB) with at least one stabilizing agent (*e.g.*, a cryopreserving agent) to form a microbial (*e.g.*, bacterial) mixture. In some examples, the method further includes removing water from the microbial (*e.g.*, bacterial) mixture forming a dried composition. For example, the method can further include freeze-drying the microbial (*e.g.*, bacterial) mixture to form a freeze-dried composition. In other examples, the method may further include combining the genetically

modified microorganism (*e.g.*, LAB) or the dried composition (*e.g.*, the freeze-dried composition) with a pharmaceutically acceptable carrier to form a pharmaceutical composition. The method may further include formulating the dried composition (*e.g.*, the freeze-dried composition) or the pharmaceutical composition into a pharmaceutical dosage
5 form.

[0048] The current disclosure further provides a genetically modified microorganism (*e.g.*, a genetically modified LAB) prepared by a method described herein (*e.g.*, a method in accordance with any of the above embodiments of Method 2).

Method 3: Method of preparing a pharmaceutical composition

10 [0049] The disclosure further provides methods for preparing a pharmaceutical composition. Exemplary methods include contacting a culture of a microorganism (*e.g.*, LAB) as disclosed herein (*e.g.*, an LAB in accordance with any of the above embodiments) with at least one stabilizing agent (*e.g.*, a cryopreserving agent), thereby forming a microbial (*e.g.*, bacterial) mixture. In some examples, the at least one stabilizing agent comprises at
15 least one cryopreserving agent. In some examples, the microorganism (*e.g.*, LAB) contains an exogenous nucleic acid encoding an interleukin-10 (IL-10) polypeptide, and further contains an exogenous nucleic acid encoding a T1D-specific antigen (*e.g.*, PINS) polypeptide, wherein the exogenous nucleic acid encoding the IL-10 polypeptide and the exogenous nucleic acid
20 encoding the T1D-specific antigen (*e.g.*, PINS) polypeptide are both chromosomally integrated, *i.e.*, are integrated into (or located on) the microbial (*e.g.*, bacterial) chromosome.

[0050] Such methods may further include removing water from the microbial (*e.g.*, bacterial) mixture, thereby forming a dried composition. For example, the methods may include freeze-drying the microbial (*e.g.*, bacterial) mixture thereby forming a freeze-dried composition.

25 [0051] In some examples according to any of the above embodiments of Method 3, the method further includes contacting the dried composition (*e.g.*, the freeze-dried composition) with a pharmaceutically acceptable carrier forming a pharmaceutical composition. The methods may further include formulating the dried composition (*e.g.*, freeze-dried composition) into a pharmaceutical dosage form, such as a tablet, a capsule, or a sachet.

Unit Dosage Forms

[0052] Accordingly, the present disclosure further provides a unit dosage form comprising a microorganism (*e.g.*, LAB) of the present disclosure, a dried composition of the present disclosure (*e.g.*, a freeze-dried composition of the present disclosure), or a pharmaceutical composition of the present disclosure. In some examples, the unit dosage form is an oral dosage form, such as a tablet, a capsule (*e.g.*, a capsule containing a powder or containing micro-pellets or micro-granules), a granule, or a sachet (*e.g.*, containing dried bacteria for suspension in a liquid for oral administration). In some embodiments, the non-pathogenic microorganism (*e.g.*, LAB) contained in the dosage form is in a dry-powder form or compacted version thereof.

[0053] In some examples according to these embodiments, the unit dosage form contains from about 1×10^4 to about 1×10^{12} colony-forming units (cfu) of the microorganism (*e.g.*, LAB). In other examples, the unit dosage form contains from about 1×10^6 to about 1×10^{12} colony forming units (cfu) of the microorganism (*e.g.*, LAB). In other examples, the unit dosage form contains from about 1×10^8 to about 1×10^{11} cfu. In yet other examples, the unit dosage form contains about 1×10^9 to about 1×10^{12} cfu.

Kits

[0054] The current disclosure further provides kits containing (1) a microorganism (*e.g.*, LAB) according to any of the embodiments disclosed herein, a composition containing a microorganism (*e.g.*, LAB) according to any of the embodiments described herein, a pharmaceutical composition containing a microorganism (*e.g.*, LAB) according to any of the embodiments described herein, or a unit dosage form containing a microorganism (*e.g.*, LAB) according to any of the embodiments described herein; and (2) instructions for administering the microorganism (*e.g.*, LAB), the composition, the pharmaceutical composition, or the unit dosage form to a mammal, *e.g.*, a human (*e.g.*, human patient).

[0055] In related embodiments, the kit may further comprise tests for ascertaining the progression of the disease and the success of treatment (*e.g.*, tests for glycemic index, insulin autoantibody (IAA) levels, fragment C levels, and insulinitis). The kit may further provide with beta cells for transplantation.

BRIEF DESCRIPTION OF THE DRAWINGS

[0056] **Figure 1A** is a graph demonstrating that an exemplary antigen-specific therapy according to the present disclosure stably reverses new-onset diabetes in NOD mice. New-onset diabetic NOD mice were treated as indicated and blood glucose concentrations were followed up for 14 weeks post-treatment initiation. Shown is the percentage of mice that remained diabetic after treatment. “†” indicates dead or moribund mice. In all Kaplan-Meier survival curves, statistical significance between groups was determined by Mantel-Cox log-rank test; * $P < 0.05$, ****, $P < 0.0001$.

[0057] **Figure 1B** depicts graphs demonstrating that an exemplary antigen-specific therapy according to the present disclosure preserves residual beta-cell function in NOD mice. Intraperitoneal glucose tolerance tests (IPGTTs) were performed on new-onset diabetic NOD mice in addition to *L. lactis*-based combination therapy (CT)-treated mice (both responders and non-responders) 1 to 2 weeks prior to treatment termination. Corresponding area under the glucose tolerance curve (AUC glucose; mg/dl \times 120 minutes) over 2 hours is shown. A responder is used herein as a subject that returns to normoglycemia (e.g. no glucosuria and blood glucose measurements >200 mg/dl) following treatment.

[0058] **Figure 1C** is a graph demonstrating that an exemplary antigen-specific therapy according to the present disclosure halts insulinitis progression in NOD mice. Insulinitis scoring was performed in a blinded manner on paraffin-embedded pancreatic sections of new-onset diabetic and *L. lactis*-based combination therapy (CT)-treated mice (both responders and non-responders), as indicated, at the end of treatment. Statistical significance between groups was calculated using Mann-Whitney t-test; ** $P < 0.01$.

[0059] **Figure 2A** is a graph showing diabetes remission rate according to starting blood glucose concentrations. New-onset diabetic NOD mice were stratified based on starting glycemia under or above 350 mg/dl at study entry. Shown is the percentage of mice that remained diabetic after combination treatment (CT) with a clinical-grade *L. lactis* strain of the present disclosure. In the Kaplan-Meier survival curve, statistical significance between groups was determined by Mantel-Cox log-rank test; ** $P < 0.01$.

[0060] **Figure 2B** is a graph showing the diabetes remission rate according to insulin autoantibody (IAA) positivity at study entry. New-onset diabetic NOD mice were stratified based on starting glycemia under or above 350 mg/dl at study entry. Shown is the percentage

of mice that remained diabetic after combination treatment (CT) with a clinical-grade *L. lactis* strain of the present disclosure.

[0061] **Figure 2C** is a graph showing that starting glycemia and positivity for IAAs at entry correlated with therapeutic success. New-onset diabetic NOD mice were stratified based on starting glycemia under or above 350 mg/dl and IAA positivity at study entry. Shown is the percentage of mice that were tolerized after therapy.

[0062] **Figure 2D** depicts graphs showing that change in IAA positivity between pre- and post-therapy was significantly different in therapy responders. Shown is IAA levels at diabetes diagnosis and after *L. lactis*-based combination treatment follow-up in therapy responders (upper panel) and non-responders (lower panel). Statistical significance between groups was calculated using Mann-Whitney t-test; ** $P < 0.01$. For one mouse the starting level of IAA was 139, outside the y-axis limit, and therefore not shown.

[0063] **Figure 3A** depicts graphs showing that *L. lactis*-based combination therapy induces higher levels of Foxp3⁺ T cells. The percentages of CD25⁺Foxp3⁺ cells (left panel), CD25⁻Foxp3⁺ cells (middle panel), and total Foxp3⁺ cells (right panel) within the CD4⁺ T cell population in peripheral blood of new-onset diabetic and *L. lactis*-based combination therapy (CT)-treated mice (both responders and non-responders). Each symbol represents one mouse, and horizontal bars indicate the median value. Statistical significance was calculated using Mann-Whitney t-test; * $P < 0.05$, ** $P < 0.01$, ***, $P < 0.001$; ****, $P < 0.0001$.

[0064] **Figure 3B** depicts graphs showing *L. lactis*-based combination therapy induces higher levels of Foxp3⁺ T cells. The percentages of CD25⁺Foxp3⁺ cells (left panel), CD25⁻Foxp3⁺ cells (middle panel), and total Foxp3⁺ cells (right panel) within the CD4⁺ T cell population in pancreatic draining lymph nodes of new-onset diabetic and *L. lactis*-based combination therapy (CT)-treated mice (both responders and non-responders). Each symbol represents one mouse, and horizontal bars indicate the median value. Statistical significance was calculated using Mann-Whitney t-test; * $P < 0.05$, ** $P < 0.01$, ***, $P < 0.001$; ****, $P < 0.0001$.

[0065] **Figure 3C** depicts graphs showing *L. lactis*-based combination therapy induces higher levels of Foxp3⁺ T cells. The percentages of CD25⁺Foxp3⁺ cells (left panel), CD25⁻Foxp3⁺ cells (middle panel), and total Foxp3⁺ cells (right panel) within the CD4⁺ T cell population in pancreas of new-onset diabetic and *L. lactis*-based combination therapy (CT)-treated mice (both responders and non-responders). Each symbol represents one mouse, and

horizontal bars indicate the median value. Statistical significance was calculated using Mann-Whitney t-test; * $P < 0.05$, ** $P < 0.01$, ***, $P < 0.001$; ****, $P < 0.0001$.

[0066] **Figure 3D** depicts graphs showing *L. lactis*-based combination therapy induces higher levels of Foxp3⁺ T cells. The percentages of CD25⁺Foxp3⁺CTLA4⁺ cells (left panel),
5 CD25⁻Foxp3⁺CTLA4⁺ cells (middle panel), and Foxp3⁺CTLA4⁺ cells (right panel) within the CD4⁺ T cell population in peripheral blood of new-onset diabetic and *L. lactis*-based combination therapy (CT)-treated mice (both responders and non-responders). Each symbol represents one mouse, and horizontal bars indicate the median value. Statistical significance was calculated using Mann-Whitney t-test; * $P < 0.05$, ** $P < 0.01$, ***, $P < 0.001$; ****, $P <$
10 0.0001.

[0067] **Figure 3E** depicts graphs showing *L. lactis*-based combination therapy induces higher levels of Foxp3⁺ T cells. The percentages of CD25⁺Foxp3⁺CTLA4⁺ cells (left panel), CD25⁻Foxp3⁺CTLA4⁺ cells (middle panel), and Foxp3⁺CTLA4⁺ cells (right panel) within the
15 CD4⁺ T cell population in pancreatic draining lymph nodes of new-onset diabetic and *L. lactis*-based combination therapy (CT)-treated mice (both responders and non-responders). Each symbol represents one mouse, and horizontal bars indicate the median value. Statistical significance was calculated using Mann-Whitney t-test; * $P < 0.05$, ** $P < 0.01$, ***, $P <$
0.001; ****, $P < 0.0001$.

[0068] **Figure 3F** depicts graphs showing *L. lactis*-based combination therapy induces
20 higher levels of Foxp3⁺ T cells. The percentages of CD25⁺Foxp3⁺CTLA4⁺ cells (left panel), CD25⁻Foxp3⁺CTLA4⁺ cells (middle panel), and Foxp3⁺CTLA4⁺ cells (right panel) within the CD4⁺ T cell population in pancreas of new-onset diabetic and *L. lactis*-based combination therapy (CT)-treated mice (both responders and non-responders). Each symbol represents one mouse, and horizontal bars indicate the median value. Statistical significance was calculated
25 using Mann-Whitney t-test; * $P < 0.05$, ** $P < 0.01$, ***, $P < 0.001$; ****, $P < 0.0001$.

[0069] **Figure 4** depicts graphs showing that *L. lactis*-based combination therapy induces suppressive IL10-secreting Foxp3⁺ T cells in responders and non-responders. For *in vitro* polyclonal suppressor assay, CD4⁺CD25⁻ effector T cells (Teff) were isolated from normoglycemic NOD mice, dye-labeled, and stimulated for 72 hours using soluble anti-CD3 in
30 the presence of accessory cells and increasing ratios of CD4⁺CD25⁺Foxp3⁺ or CD4⁺CD25⁻Foxp3⁺ T cells (Treg), isolated from *L. lactis*-based combination therapy (CT)-treated NOD.Foxp3.hCD2 mice (both responders and non-responders) at the end of the indicated 6-week treatment. Proliferation of Teff cells was measured by flow cytometric analysis of dye

dilution and shown as the percentage of Teff cells undergone two or more divisions, normalized to effector only culture. Activation of Teff cells was measured by flow cytometric analysis of CD69 and shown as the MFI, normalized to effector only culture. MSD high-sensitivity multiplex assay of IFN- γ and IL10 concentrations in the Treg:Teff cultures.

5 Statistical significance between groups was calculated using Kruskal-Wallis test followed by Dunnett's multiple testing; * P < 0.05, ** P < 0.01, ***, P < 0.001; * P < 0.05, ** P < 0.01.

[0070] **Figure 5A** is a graph showing *L. lactis*-based combination therapy-induced Tregs depend on CTLA4 and TGF- β to control T effector cell responses. T effector (Teff) proliferation – shown as the percentage of Teff cells that had undergone two or more divisions, normalized to proliferation by effector only culture. Dye-labeled CD4⁺CD25⁻ T cells (Teff)

10 were stimulated with anti-CD3 (0.5 μ g/ml) in the presence of accessory cells and CD4⁺CD25⁺Foxp3⁺, isolated from *L. lactis*-based combination therapy (CT)-treated NOD.Foxp3.hCD2 mice (both responders and non-responders), and indicated neutralizing antibodies (10 μ g/ml). Statistical significance between groups was calculated using Kruskal-

15 Wallis test followed by Dunnett's multiple testing; * P < 0.05, ** P < 0.01, *** P < 0.001.

[0071] **Figure 5B** is a graph showing *L. lactis*-based combination therapy-induced Tregs depend on CTLA4 and TGF- β to control T effector cell responses. T effector (Teff) proliferation – shown as the percentage of Teff cells that had undergone 2 or more divisions, normalized to proliferation by effector only culture. Dye-labeled CD4⁺CD25⁻ T cells (Teff)

20 were stimulated with anti-CD3 (0.5 μ g/ml) in the presence of accessory cells and CD4⁺CD25⁻ Foxp3⁺ cells (Treg), isolated from *L. lactis*-based combination therapy (CT)-treated NOD.Foxp3.hCD2 mice (both responders and non-responders), and indicated neutralizing antibodies (10 μ g/ml). Statistical significance between groups was calculated using Kruskal-

Wallis test followed by Dunnett's multiple testing; * P < 0.05, ** P < 0.01, *** P < 0.001.

25 [0072] **Figure 5C** is a graph showing that *L. lactis*-based combination therapy-induced Tregs depend on CTLA4 and TGF- β to control T effector cell responses. *L. lactis*-based combination therapy-cured mice were injected with anti-CTLA4 and anti-TGF- β antibodies (n=5) and followed up for diabetes recurrence (glucosuria and blood glucose measurements >200 mg/dl and).

30 [0073] **Figure 6A** is a treatment scheme for the simultaneous administration of *L. lactis*-based combination therapy (CT) and the specific FOXP3 inhibitor P60 (i.p. 50 μ g/daily) in new-onset diabetic NOD mice.

- [0074] **Figure 6B** is a graph showing that specific inhibition of Treg function impairs therapy-induced tolerance. Shown is the percentage of mice that remained diabetic after treatment. In the Kaplan-Meier survival curve, statistical significance between groups was determined by Mantel-Cox log-rank test; * $P < 0.05$.
- 5 [0075] **Figure 7A** is a treatment scheme for Foxp3⁺ T cell depletion by diphtheria toxin (DT) in *L. lactis*-based combination therapy (CT)-cured NOD.Foxp3.DTR mice.
- [0076] **Figure 7B** is a graph showing that Foxp3⁺ T cell depletion breaches *L. lactis*-based combination therapy-induced tolerance in NOD.Foxp3.DTR mice. Blood glucose measurements in new-onset diabetic NOD.Foxp3.DTR mice during *L. lactis*-based
10 combination therapy (n=7) and after DT treatment (n=4). Mice were considered cured (white symbols) when random blood glucose concentrations recovered to beneath 200 mg/dl or non-cured (black symbols) when mice sustained blood glucose concentrations above 200 mg/dl.
- [0077] **Figure 7C** is a graph showing insulinitis scoring in the pancreas of therapy-cured NOD.Foxp3.DTR mice before and after DT treatment.
- 15 [0078] **Figure 7D** is a graph showing the quantification of islet-resident Foxp3⁺ T cells in the pancreas of therapy-cured NOD.Foxp3.DTR mice before and after DT treatment. Staining of pancreas sections from combination therapy-tolerized mice for insulin (red), CD4 (purple) and Foxp3 (green) in which the white arrow heads indicate the presence of Foxp3⁺ T cells within an islet of Langerhans with some insulin positivity. Higher magnification of the boxed
20 area clearly indicates that Foxp3⁺ cells are CD4⁺ T-cells. Statistical significance was calculated using Mann-Whitney t-test; ****, $P < 0.0001$.
- [0079] **Figure 8A** depicts graphs showing the percentages of CTLA4⁺ cells within the CD4⁺CD25⁺Foxp3⁺ (left), CD4⁺CD25⁻Foxp3⁺ (middle), and CD4⁺Foxp3⁺ (right) T cell population in peripheral blood of new-onset diabetic and *L. lactis*-based combination therapy
25 (CT)-treated mice (both responders and non-responders). Each symbol represents one mouse, and horizontal bars indicate the median value. Statistical significance was calculated using Mann-Whitney t-test; * $P < 0.05$, ** $P < 0.01$, ***, $P < 0.001$; ****, $P < 0.0001$.
- [0080] **Figure 8B** depicts graphs showing the percentages of CTLA4⁺ cells within the CD4⁺CD25⁺Foxp3⁺ (left), CD4⁺CD25⁻Foxp3⁺ (middle), and CD4⁺Foxp3⁺ (right) T cell
30 population in pancreatic draining lymph nodes of new-onset diabetic and *L. lactis*-based combination therapy (CT)-treated mice (both responders and non-responders). Each symbol represents one mouse, and horizontal bars indicate the median value. Statistical significance

was calculated using Mann-Whitney t-test; * P < 0.05, ** P < 0.01, ***, P < 0.001; ****, P < 0.0001.

[0081] **Figure 8C** depicts graphs showing the percentage of CTLA4⁺ cells within the CD4⁺CD25⁺Foxp3⁺ (left), CD4⁺CD25⁻Foxp3⁺ (middle), and CD4⁺Foxp3⁺ (right) T cell population in pancreas of new-onset diabetic and *L. lactis*-based combination therapy (CT)-treated mice (both responders and non-responders). Each symbol represents one mouse, and horizontal bars indicate the median value. Statistical significance was calculated using Mann-Whitney t-test; * P < 0.05, ** P < 0.01, ***, P < 0.001; ****, P < 0.0001.

[0082] **Figure 9** is graph showing that *L. lactis*-based combination therapy-tolerized mice are not depleted in pathogenic T effector cells. Adoptive transfer of total splenocytes (1×10^7) isolated from overtly diabetic (white diamonds), combination therapy (CT) responders (white circles) or non-responders (crossed circles). Statistical calculations were performed using Mantel-Cox log-rank test; “ns”: not significant.

[0083] **Figure 10A** is schematic scheme to deplete Foxp3⁺ cells with DT in NOD.Foxp3.DTR mice. Four consecutive i.p. (intraperitoneal) DT injections (on day (d) 1, 2, 5 and 7) (40 µg/kg body weight/d) are indicated in the scheme.

[0084] **Figure 10B** depicts graphs showing depletion of Foxp3⁺ cells with DT in NOD.Foxp3.DTR mice. Flow cytometric analysis of peripheral blood demonstrated efficient depletion of Foxp3⁺ cells in DT-treated NOD.Foxp3.DTR mice. Foxp3 staining of pancreas sections showed effective depletion of islet-resident Foxp3⁺ cells in DT-treated NOD.Foxp3.DTR mice.

[0085] **Figure 10C** depicts representative flow cytometric profiles showing the percentage of CD4⁺ T cells positive for Foxp3 and the DTR-GFP fusion protein before (d0) and after two consecutive DT injections (d3 and 5) of NOD.Foxp3.DTR mice (left panel).

[0086] **Figure 10D** is a graph demonstrating rapid diabetes onset upon acute Foxp3⁺ Treg depletion in NOD.Foxp3.DTR mice.

[0087] **Figure 11** is a representation of an exemplary IL-10 expression cassette (SEQ ID NO: 13) comprising an *hllA* promoter (*PhllA*), an IL-10 secretion sequence (SSusp45), and an exemplary nucleic acid sequence encoding human IL-10 (and a corresponding amino acid sequence), which sequence is used without its native signal peptide and includes a (Pro to Ala) point mutation at position 2 of the indicated IL-10 sequence (hIL10aPxA). SEQ ID NO: 14 is the amino acid sequence of the IL-10 secretion sequence linked to the human IL-10 sequence.

[0088] **Figures 12A and 12B** are collectively a representation of an exemplary PINS polycistronic expression cassette (SEQ ID NO: 15) containing a *gapB* promoter (P_{gapB}), the *gapB* gene, an exemplary intergenic region (*rpmD*), an exemplary PINS secretion sequence (SSusp45) translationally coupled to an exemplary nucleic acid sequence encoding human PINS. SEQ ID NO: 16 is the amino acid sequence encoded by the *gapB* gene. SEQ ID NO: 17 is the amino acid sequence encoded by the PINS secretion sequence and the translationally coupled human PINS sequence.

[0089] **Figures 13A, 13B, and 13C** (SEQ ID NO: 18) are collectively a representation of a deletion of the trehalose-6-phosphate phosphorylase gene (*trePP*; Gene ID: 4797140); Insertion of the constitutive promoter of the HU-like DNA-binding protein gene (*PhllA*; Gene ID: 4797353) to precede the putative phosphotransferase genes in the trehalose operon (*trePTS*; *llmg_0453* and *llmg_0454*; *ptsI* and *ptsII*; Gene ID: 4797778 and Gene ID: 4797093 respectively), insertion of the intergenic region preceding the highly expressed *L. lactis* MG1363 50S ribosomal protein L30 gene (*rpmD*; Gene ID: 4797873) in between *ptsI* and *ptsII*.

[0090] **Figures 14A and 14B** (SEQ ID NO: 19) are collectively a representation of insertion of trehalose-6-phosphate phosphatase gene (*otsB*; Gene ID: 1036914) downstream of unidentified secreted 45-kDa protein gene (*usp45*; Gene ID: 4797218). Insertion of the intergenic region preceding the highly expressed *L. lactis* MG1363 50S ribosomal protein L30 gene (*rpmD*; Gene ID: 4797873) between *usp45* and *otsB*.

[0091] **Figures 15A and 15B** (SEQ ID NO: 20) are collectively a representation of insertion of *tga* at codon position 30 of 446 (*tga30*), alongside with the introduction of an *EcoRI* restriction site, to disrupt the gene encoding cellobiose-specific PTS system IIC component (*ptcC*; Gene ID: 4796893).

[0092] **Figure 16** (SEQ ID NO: 22) is a representation of insertion of a gene encoding a fusion of *usp45* secretion leader (SSusp45) with the *pins* gene, encoding human proinsulin (PINS; UniProt: P01308, amino acids 25-110), downstream of the highly expressed glyceraldehyde 3-phosphate dehydrogenase gene (*gapB*; Gene ID: 4797877). Insertion of the intergenic region preceding the highly expressed *L. lactis* MG1363 50S ribosomal protein L30 gene (*rpmD*; Gene ID: 4797873) between *gapB* and *pins*.

[0093] **Figure 17** (SEQ ID NO: 23) is a representation of deletion of thymidylate synthase gene (*thyA*; Gene ID: 4798358). Downstream of the constitutive promoter of the HU-like DNA-binding protein gene (*PhllA*; Gene ID: 4797353), insertion of a gene encoding

a fusion (SEQ ID NO: 24) of SSusp45 with the hil-10 gene, encoding human interleukin-10 (hIL-10; UniProt: P22301, aa 19-178, variant P2A, Steidler *et al.*, *Nat. Biotechnol.* 2003, 21(7): 785-789) is inserted to allow expression and secretion of hIL-10.

[0094] **Figure 18:** Schematic overview of relevant genetic loci of sAGX0407 as described: trePTS, Δ trePP; otsB; ptcC-; gapB>>pins and Δ thyA, hIL-10 with indication of the relevant oligonucleotide binding sites (oAGXno), EcoRI restriction site, (/truncated/) genetic characters, intergenic regions (IR), PCR amplification product sizes (bp).

DETAILED DESCRIPTION

[0095] Provided are compositions and methods for the treatment of T1D, and/or for restoring tolerance to T1D-specific antigens (*i.e.*, PINS) in a subject.

Definitions

[0096] As used in the specification and embodiments, the singular forms “a,” “an” and “the” include plural references unless the context clearly dictates otherwise. For example, the term “a cell” includes a plurality of cells, including mixtures thereof. Similarly, use of “a compound” for treatment or preparation of medicaments as described herein contemplates using one or more compounds of this invention for such treatment or preparation unless the context clearly dictates otherwise.

[0097] As used herein, the term “comprising” is intended to mean that the compositions and methods include the recited elements, but not excluding others. “Consisting essentially of” when used to define compositions and methods, shall mean excluding other elements of any essential significance to the combination. Thus, a composition consisting essentially of the elements as defined herein would not exclude trace contaminants from the isolation and purification method and pharmaceutically acceptable carriers, such as phosphate buffered saline, preservatives, and the like. “Consisting of” shall mean excluding more than trace elements of other ingredients and substantial method steps for administering the compositions of this invention. Embodiments defined by each of these transition terms are within the scope of this invention.

[0098] As used herein, the term “expressing” a gene or polypeptide or “producing” a polypeptide (*e.g.*, an IL-10 polypeptide or T1D-specific antigen polypeptide), or “secreting” a polypeptide is meant to include “capable of expressing” and “capable of producing,” or “capable of secreting,” respectively. For example, a microorganism, which contains an

exogenous nucleic acid can under sufficient conditions (*e.g.*, sufficient hydration and/or in the presence of nutrients) express and secrete a polypeptide encoded by an exogenous nucleic acid. However, the microorganism may not always actively express the encoded polypeptide. The microorganism (*e.g.*, bacterium) may be dried (*e.g.*, freeze-dried), and in that state can be considered dormant (*i.e.*, is not actively producing polypeptide). However, once the
5 microorganism is subjected to sufficient conditions, *e.g.*, is administered to a subject and is released (*e.g.*, in the gastro-intestinal tract of the subject) it may begin expressing and secreting polypeptide. Thus, a microorganism “expressing” a gene or polypeptide, “producing” a polypeptide, or “secreting” a polypeptide of the current disclosure includes the
10 microorganism in its “dormant” state. As used herein, “secrete” means that the protein is exported outside the cell and into the culture medium/supernatant or other extracellular milieu.

[0099] As used herein, the term “constitutive” in the context of a promoter (or by extension relating to gene expression or secretion of a polypeptide) refers to a promoter that
15 allows for continual transcription of its associated gene. A constitutive promoter compares to an “inducible” promoter.

[00100] The term “about” in relation to a reference numerical value, and its grammatical equivalents as used herein, can include the reference numerical value itself and a range of values plus or minus 10% from that reference numerical value. For example, the term “about
20 10” includes 10 and any amounts from and including 9 to 11. In some cases, the term “about” in relation to a reference numerical value can also include a range of values plus or minus 10%, 9%, 8%, 7%, 6%, 5%, 4%, 3%, 2%, or 1% from that reference numerical value. In some embodiments, “about” in connection with a number or range measured by a particular method indicates that the given numerical value includes values determined by the
25 variability of that method.

[00101] An “IL-10 gene” refers to an interleukin 10 gene encoding an “IL-10 polypeptide.” The term “IL-10 gene” includes “IL-10 variant genes” encoding “IL-10 variant polypeptides.” The DNA sequence encoding IL-10 in an LAB may be codon optimized to facilitate expression in LAB, and as such may differ from that in the native organism (*e.g.*,
30 humans).

[00102] The term “IL-10” or “IL-10 polypeptide” refers to a functional, IL-10 polypeptide (*e.g.*, human IL-10 polypeptide) that has at least the amino acid sequence of the mature form

(*i.e.* without its secretion signal), but also includes membrane-bound forms and soluble forms, as well as “IL-10 variant polypeptides.”

[00103] An “IL-10 variant” or “IL-10 variant polypeptide” refers to a modified (*e.g.*, truncated or mutated), but functional IL-10 polypeptide, *e.g.*, a truncated or mutated version of human IL-10. The term “IL-10 variant polypeptide” includes IL-10 polypeptides with enhanced activity or diminished activity when compared to a corresponding wild-type IL-10 polypeptide. An “IL-10 variant polypeptide” retains at least some IL-10 activity (functional polypeptide).

[00104] The “percentage identity” between polypeptide sequences can be calculated using commercially available algorithms which compare a reference sequence with a query sequence. In some embodiments, polypeptides are 70%, at least 70%, 75%, at least 75%, 80%, at least 80%, 85%, at least 85%, 90%, at least 90%, 92%, at least 92%, 95%, at least 95%, 97%, at least 97%, 98%, at least 98%, 99%, or at least 99% or 100% identical to a reference polypeptide, or a fragment thereof (*e.g.*, as measured by BLASTP or CLUSTAL, or other alignment software) using default parameters. Similarly, nucleic acids can also be described with reference to a starting nucleic acid, *e.g.*, they can be 50%, at least 50%, 60%, at least 60%, 70%, at least 70%, 75%, at least 75%, 80%, at least 80%, 85%, at least 85%, 90%, at least 90%, 95%, at least 95%, 97%, at least 97%, 98%, at least 98%, 99%, at least 99%, or 100% identical to a reference nucleic acid or a fragment thereof (*e.g.*, as measured by BLASTN or CLUSTAL, or other alignment software using default parameters). When one molecule is said to have a certain percentage of sequence identity with a larger molecule, it means that when the two molecules are optimally aligned, the percentage of residues in the smaller molecule finds a match residue in the larger molecule in accordance with the order by which the two molecules are optimally aligned, and the “%” (percent) identity is calculated in accord with the length of the smaller molecule.

[00105] The term “chromosomally integrated” or “integrated into a chromosome” or any variation thereof means that a nucleic acid sequence (*e.g.*, gene; open reading frame; exogenous nucleic acid encoding a polypeptide; promoter; expression cassette; and the like) is located on (integrated into) a microbial (*e.g.*, bacterial) chromosome, *i.e.*, is not located on an episomal vector, such as a plasmid. In some embodiments, in which the nucleic acid sequence is chromosomally integrated, the polypeptide encoded by such chromosomally integrated nucleic acid is constitutively expressed.

[00106] The terms “self-antigen” or “auto-antigen” are used interchangeably herein. The terms are used herein in accordance with the art recognized meaning of self-antigen or auto-antigen, and generally refer to a polypeptide/protein originating from within a subject's own body (produced by the subject's own body), wherein the antigen is recognized by the subject's own immune system, and typically produces antibodies against such antigen. Autoimmune diseases are generally associated with certain disease-specific self-antigens. For example, in T1D a subject's immune system may produce antibodies against at least one antigen associated with the beta-cell destruction process. Such self-antigens include proinsulin (PINS), glutamic acid decarboxylase (GAD65), insulinoma-associated protein 2 (IA-2), islet-specific glucose-6-phosphatase catalytic subunit-related protein (IGRP) and zinc transporter (ZnT) 8. Clinical T1D may further be associated with additional candidate target molecules expressed by beta-cells such as chromogranin A, (prepro) islet amyloid polypeptide (ppIAPP), peripherin and citrullinated glucose-regulated protein (GRP).

[00107] The term “T1D-specific antigen gene” refers to a gene encoding the above “T1D-specific antigen.” The term “T1D-specific antigen gene” includes “T1D-specific antigen variant genes” encoding “T1D-specific antigen variant polypeptides.” The DNA sequence encoding T1D antigen in an LAB may be codon optimized to facilitate expression in LAB, and as such may differ from that in the native organism (*e.g.* humans).

[00108] The term “T1D-specific antigen polypeptide” refers to a functional, *e.g.*, full-length, polypeptide, as well as “T1D-specific antigen variant polypeptides,” which may have enhanced activity or diminished activity when compared to a corresponding wild-type polypeptide. The T1D specific antigen may also lack the eukaryotic signal sequences.

[00109] The term “T1D-specific antigen variant” or “T1D-specific antigen variant polypeptide” refers to a modified (*e.g.*, truncated or mutated), but functional polypeptide, *e.g.*, a truncated or mutated version of human PINS. The term “variant polypeptide” includes polypeptides with enhanced activity or diminished activity when compared to a corresponding wild-type polypeptide. A “variant polypeptide” retains at least some biological activity (functional polypeptide). Exemplary variants of GAD65 and IA-2 include trimmed versions thereof (*e.g.*, GAD65₃₇₀₋₅₇₅, and IA-2₆₃₅₋₉₇₉, respectively; relative to NCBI accession numbers NP_000809.1 and NP_002837.1 retaining antigenic properties, and are thus useful in the compositions and methods of the current disclosure, *e.g.*, in stimulating Tregs and inducing tolerance in a subject. Generally, trimmed or truncated versions of a T1D-

specific antigen are efficiently expressed and secreted by the microorganism (*e.g.*, *Lactococcus lactis*).

[00110] The term “operably linked” refers to a juxtaposition wherein the components described are in a relationship permitting them to function in their intended manner. A control sequence “operably linked” to a coding sequence is ligated in such a way that expression of the coding sequence is achieved under condition compatible with the control sequences. For example, a promoter is said to be operably linked to a gene, open reading frame or coding sequence, if the linkage or connection allows or effects transcription of said gene. In a further example, a 5’ and a 3’ gene, cistron, open reading frame or coding sequence are said to be operably linked in a polycistronic expression unit, if the linkage or connection allows or effects translation of at least the 3’ gene. For example, DNA sequences, such as, *e.g.*, a promoter and an open reading frame, are said to be operably linked if the nature of the linkage between the sequences does not (1) result in the introduction of a frame-shift mutation, (2) interfere with the ability of the promoter to direct the transcription of the open reading frame, or (3) interfere with the ability of the open reading frame to be transcribed by the promoter region sequence.

Anti-CD3 Antibody

[00111] An “anti-CD3 antibody” can be any antibody that binds to a CD3 receptor on the surface of a T cell, *e.g.*, an antibody that targets the epsilon chain of CD3 (CD3E). The term “anti-CD3 antibody” includes any fragment of such antibody, such as Fab fragments, single domain antibodies, nanobodies and the like. In some examples, the anti-CD3 antibody or fragment thereof is a monoclonal antibody. In other examples, the anti-CD3 antibody is a humanized monoclonal antibody, *e.g.*, a chimeric or humanized hybrid antibody. In some examples, the anti-CD3 antibody is a single domain antibody or nanobody. In other examples, the anti-CD3 antibody is muromonab-CD3. Other known monoclonal anti-CD3 antibodies include oteelixizumab, teplizumab and visilizumab, and fragments thereof. These antibodies are being investigated for the treatment of conditions like Crohn’s disease, ulcerative colitis and type 1 diabetes (*see, e.g.*, Herold K.C. and Taylor L.; “Treatment of Type 1 diabetes with anti-CD3 monoclonal antibody: induction of immune regulation?”. *Immunologic Research* 2003, 28 (2): 141–50) and for inducing immune tolerance. *See, e.g.*, Bisikirska *et al.* “TCR stimulation with modified anti-CD3 mAb expands CD8+ T cell population and induces CD8+CD25+ Tregs” (2005), and Bisikirska *et al.*, “Use of Anti-CD3 Monoclonal Antibody to Induce Immune Regulation in Type 1 Diabetes”. *Annals of the New*

York Academy of Sciences 2004, 1037: 1–9. In some examples, the anti-CD3 antibody blocks the function of effector T cells (*e.g.*, which attack and destroy insulin-producing beta-cells) and/or stimulates regulatory T cells. Thus, in some examples, the anti-CD3 antibody protects a subject against effector T cell damage, *e.g.*, preserving the ability of beta-cells to produce insulin. In some examples, the anti-CD3 antibody is suitable for administration to a human, *e.g.*, is the subject of a clinical trial or has already been approved by a regulatory agency. In some examples, the anti-CD3 antibody is oteelixizumab or teplizumab.

Recent-Onset T1D

[00112] The inventors have discovered that subjects with certain minimal amounts of residual beta-cell function respond particularly well to the therapeutic methods described herein. Residual beta-cell function may be measured in accordance with art recognized methods and as described herein. However, sufficient residual beta-cell function is typically found in subjects who have not been exposed to harmful auto-immune functions targeting the subject's beta-cells for too long. Thus, in some embodiments, the mammalian subject in the above methods has recently been diagnosed with T1D. For example, such subject may be referred to as having "recent-onset T1D" or "new-onset T1D" (used interchangeably herein). In some examples according to these embodiments, the subject has been diagnosed with T1D within the previous 12 months, the previous 18 months, or the previous 24 months prior to administering a composition according to the present disclosure. In other examples, the subject has been treated with insulin for less than about 12 weeks, less than about 8 weeks, less than about 6 weeks, or less than about 4 weeks. In other examples, according to any of the above embodiments, the subject tested positive for at least one auto-antibody, *e.g.*, tested positive for insulin autoantibody (IAA), islet-cell auto-antibodies, glutamic acid decarboxylase (*e.g.*, GAD65) auto-antibodies, and/or ICA512 antibodies. In other examples, according to any of the above embodiments, the subject has a fasting plasma glucose level of greater than about 100 mg/dL, or greater than about 120 mg/dL, or greater than about 126 mg/dL. In other examples, according to any of the above embodiments, the subject has a fasting plasma glucose level of about 180 to about 250 mg per deciliter (mg/dL), or about 10 mmol/L to about 14 mmol/L. In other examples, according to any of the above embodiments, the subject has a plasma glucose level of about 100 to about 500 mg/dL. In other examples, according to any of the above embodiments, the subject had polyuria for less than about 8 months, less than about 6 months, or less than about 4 months.

[00113] In some examples, a human subject may be categorized as having early onset T1D when any one of the following is measured in the subject: (1) two consecutive fasting blood glucose tests are equal to or greater than 126 mg/dL; (2) when any random blood glucose measurement is greater than 200 mg/dL; (3) a hemoglobin A1c (HbA1c) test that is equal to or greater than 6.5 percent (HbA1c is a blood test that gives a three month average of blood sugars); or (4) a two-hour oral glucose tolerance test with any value over 200 mg/dL, or combinations thereof. Thus, normal glycemia may be characterized by any of the following: (1) two consecutive fasting blood glucose tests are below 126 mg/dL, below 120 mg/dL, or below 100 mg/dL; (2) when any random blood glucose measurement is below 200 mg/dL, below 180 mg/dL, below 160 mg/dL, or below 140 mg/dL; (3) a hemoglobin A1c (HbA1c) test that is less than 6.5 percent, or less than 6%; or (4) a two-hour oral glucose tolerance test with a value below 200 mg/dL, below 180 mg/dL, below 160 mg/dL, or below 140 mg/dL, or any combination thereof.

[00114] A subject that returns to normoglycemia (*e.g.* no glucosuria and blood glucose measurements >200 mg/dl) following treatment may be considered to be a “responder” to the treatment. Subject who do not return to substantial normoglycemia are “non-responders”.

[00115] The concentrations of C-peptide in the blood or urine of a subject may be used to assess a subject’s beta-cell function and the T1D disease stage, where higher concentrations of C-peptide indicate higher beta-cell function. In some examples, the subject (*e.g.*, human patient) has recent-onset T1D, characterized by having a fasting blood C-peptide concentration of less than about 1 nmol/L, but at least about 0.2 nmol/L. In other embodiments, the recent-onset subject (*e.g.*, human patient) has a stimulated blood C-peptide concentration, *e.g.*, during a 4-hour mixed meal tolerance test (MMTT) of less than about 5 nmol/L, but at least about 0.2 nmol/L, or less than about 4 nmol/L, but at least about 0.5 nmol/L. Other suitable C-peptide ranges are described herein. Stimulated C-peptide may thus be measured using MMTT area under the curve C-peptide (AUC CP), or may alternatively be measured using a 90 minute MMTT stimulated CP (90CP post MMTT or 90CP).

Promoter

[00116] By “promoter” is meant generally a region on a nucleic acid molecule, for example DNA molecule, to which an RNA polymerase binds and initiates transcription. A promoter is for example, positioned upstream, *i.e.*, 5’, of the sequence the transcription of which it controls. The skilled person will appreciate that the promoter may be associated with

additional native regulatory sequences or regions, *e.g.* operators. The precise nature of the regulatory regions needed for expression may vary from organism to organism, but shall in general include a promoter region which, in prokaryotes, contains both the promoter (which directs the initiation of RNA transcription) as well as the DNA sequences which, when transcribed into RNA, will signal the initiation of protein synthesis. Such regions will normally include those 5'-non-coding sequences involved with initiation of transcription and translation, such as the Pribnow-box (*cf.* TATA-box), Shine-Dalgarno sequence, and the like.

Expression Cassette

[00117] The term “expression cassette” or “expression unit” is used in accordance with its generally accepted meaning in the art, and refers to a nucleic acid containing one or more genes and sequences controlling the expression of the one or more genes. Exemplary expression cassettes contain at least one promoter sequence and at least one open reading frame.

Polycistronic Expression Cassette

[00118] The terms “polycistronic expression cassette” “polycistronic expression unit” or “polycistronic expression system” are used herein interchangeably and in accordance with their generally accepted meaning in the art. They refer to a nucleic acid sequence wherein the expression of two or more genes is regulated by common regulatory mechanisms, such as promoters, operators, and the like. The term polycistronic expression unit as used herein is synonymous with multicistronic expression unit. Examples of polycistronic expression units are without limitation bicistronic, tricistronic, tetracistronic expression units. Any mRNA comprising two or more, such as 3, 4, 5, 6, 7, 8, 9, 10, or more, open reading frames or coding regions encoding individual expression products such as proteins, polypeptides and/or peptides is encompassed within the term polycistronic. A polycistronic expression cassette includes at least one promoter, and at least two open reading frames controlled by the promoter, wherein an intergenic region is optionally placed between the two open reading frames.

[00119] In some example, the “polycistronic expression cassette” includes one or more endogenous genes and one or more exogenous genes that are transcriptionally controlled by a promoter which is endogenous to the microorganism (*e.g.*, LAB). The polycistronic expression unit or system as described herein can be transcriptionally controlled by a promoter that is exogenous to the microorganism (*e.g.*, LAB). In a further embodiment, the

translationally or transcriptionally coupled one or more endogenous genes and one or more exogenous genes as described herein are transcriptionally controlled by the native promoter of (one of) said one or more endogenous genes. In another embodiment, the polycistronic expression unit is transcriptionally controlled by the native promoter of (one of) said one or more endogenous genes comprised in said polycistronic expression unit. In another embodiment, the polycistronic expression unit is operably linked to a gram-positive endogenous promoter. In an exemplary embodiment, the promoter may be positioned upstream of, *i.e.*, 5' of the open reading frame(s) to which it is operably linked. In a further embodiment, the promoter is the native promoter of the 5' most, *i.e.*, most upstream, endogenous gene in the polycistronic expression unit. Accordingly, in some examples, the polycistronic expression unit contains an endogenous gene and one or more exogenous genes transcriptionally coupled to the 3' end of said one or more endogenous gene, for example wherein said one or more exogenous gene(s) is (are) the most 3' gene(s) of the polycistronic expression unit.

15 [00120] As used herein, the term "translationally coupled" is synonymous with "translationally linked" or "translationally connected". These terms in essence relate to polycistronic expression cassettes or units. Two or more genes, open reading frames or coding sequences are said to be translationally coupled when common regulatory element(s) such as in particular a common promoter effects the transcription of said two or more genes as one mRNA encoding said two or more genes, open reading frames or coding sequences, which can be subsequently translated into two or more individual polypeptide sequences. The skilled person will appreciate that bacterial operons are naturally occurring polycistronic expression systems or units in which two or more genes are translationally or transcriptionally coupled.

25 ***Intergenic Region***

[00121] As used herein, the term "intergenic region" is synonymous with "intergenic linker" or "intergenic spacer". An intergenic region is defined as a polynucleic acid sequence between adjacent (*i.e.*, located on the same polynucleic acid sequence) genes, open reading frames, cistrons or coding sequences. By extension, the intergenic region can include the stop codon of the 5' gene and/or the start codon of the 3' gene which are linked by said intergenic region. As defined herein, the term intergenic region specifically relates to intergenic regions between adjacent genes in a polycistronic expression unit. For example, an intergenic region

as defined herein can be found between adjacent genes in an operon. Accordingly, in an embodiment, the intergenic region as defined herein is an operon intergenic region.

[00122] In some examples, the intergenic region, linker or spacer is selected from intergenic regions preceding, *i.e.*, 5' to, more particularly immediately 5' to, *rp/W*, *rpf P*,
5 *rpmD*, *rp/8*, *rpsG*, *rpsE* or *rp/N* of a gram-positive bacterium. In an embodiment, said gram positive bacterium is a lactic acid bacterium, for example a *Lactococcus* species, *e.g.*, *Lactococcus lactis*, and any subspecies or strain thereof. In an embodiment, said intergenic region encompasses the start codon of *rp/W*, *rp/P*, *rpmD*, *rp/8*, *rpsG*, *rpsE* or *rp/N* and/or the stop codon of the preceding, *i.e.* 5', gene. In a preferred embodiment, the invention relates to
10 a gram-positive bacterium or a recombinant nucleic acid as described herein, wherein the endogenous gene and the one or more exogenous genes are transcriptionally coupled by intergenic region or regions active in the gram-positive bacterium, for example wherein the intergenic region or regions is endogenous to said gram-positive bacterium, for example, wherein the endogenous intergenic region is selected from intergenic regions preceding *rp/W*,
15 *rpf P*, *rpmD*, *rp/8*, *rpsG*, *rpsE*, *rp/N*, *rplM*, *rplE*, and *rplF*.

[00123] The skilled person will appreciate that if the intergenic region encompasses a 5' stop codon and/or a 3' start codon, these respective codons in some cases are not present in the genes which are linked by said intergenic regions, in order to avoid double start and/or stop codons, which may affect correct translation initiation and/or termination. Methods for
20 identifying intergenic regions are known in the art. By means of further guidance, intergenic regions can for instance be identified based on prediction of operons, and associated promoters and open reading frames, for which software is known and available in the art. Exemplary intergenic regions are described in international patent application publication WO2012/164083, the disclosure of which is incorporated herein by reference in its entirety.

25 **Subject**

[00124] A "subject" is an organism, which may benefit from being administered a composition of the present disclosure, *e.g.*, according to methods of the present disclosure. The subject may be a mammal ("mammalian subject"). Exemplary mammalian subjects include humans, farm animals (such as cows, pigs, horses, sheep, goats), pets or domesticated
30 animals (such as a dogs, cats, and rabbits), and other animals, such as mice, rats, and primates. In some examples, the mammalian subject is a human patient.

[00125] The term “international unit” (IU) is used herein in accordance with its art-recognized meaning and represents an amount of a substance (*e.g.*, polypeptide). The mass or volume that constitutes one international unit varies based on which substance is being measured. The World Health Organization (WHO) provides unit characterizations for
5 bioactive polypeptides.

T1D Specific Antigen

[00126] The at least one microorganism of the present disclosure contains an exogenous nucleic acid encoding at least one disease-specific (*i.e.*, T1D-specific) self-antigen gene, and can express such gene under conditions sufficient for expression. Exemplary T1D-specific
10 self-antigens include islet antigens associated with the beta-cell destruction process. In some embodiments, in any of the above compositions and methods, the T1D-specific antigen is selected from known auto-antigens associated with T1D, and include proinsulin (PINS); insulin (INS); glutamic acid decarboxylase (GAD) (*e.g.*, GAD65, GAD67, or GAD2); insulinoma-associated protein 2 (islet antigen-2; IA-2) (also referred to as protein tyrosine
15 phosphatase, receptor type, N (PTPRN), tyrosine phosphatase-like protein, or ICA512), (*see, e.g.*, Long *et al.*, *Diabetes* 2013, 62 (6), 2067-2071); islet-specific glucose-6-phosphatase catalytic subunit-related protein (IGRP), zinc transporter 8 (ZnT8). Other examples include molecules expressed by beta-cells, such as chromogranin A, (prepro) islet amyloid polypeptide (ppIAPP), peripherin, citrullinated glucose-regulated protein (*e.g.*, GRP78); *see,*
20 *e.g.*, Rondas *et al.*, *Diabetes* 2015; 64(2):573-586; and Ye *et al.*, *Diabetes* 2010, 59(1):6-16), and combinations of two or more of these antigens. In other embodiments, in the above compositions and methods, the T1D-specific antigen is PINS, GAD65, or IA-2. In other embodiments, in the above compositions and methods, the T1D-specific antigen is PINS. In various embodiments, the T1D-specific antigen is encoded by a variant nucleic acid sequence
25 shorter than a full length (*e.g.*, wild-type) gene, as such “trimmed” versions are often more efficiently expressed and/or secreted by the microorganisms used (*e.g.*, *Lactococcus lactis*). While secretion is more efficient, many “trimmed” versions retain all (or a substantial portion) of their biological activity, *e.g.*, retain sufficient Treg stimulating and/or tolerance-inducing capacities.

30 [00127] Examples of PINS polypeptides include wild-type human PINS and polypeptides having at least about 60%, at least about 70%, at least about 80%, at least about 90%, at least about 95%, at least about 96%, at least about 97%, at least about 98%, or at least about 99% sequence identity with such wild-type human PINS. An exemplary amino acid sequence of

wild-type human PINS is SEQ ID NO: 5, and an exemplary nucleic acid sequence is represented by SEQ ID NO: 6 (see CDS contained in accession number NM_000207.2). In some examples, the PINS polypeptide has an amino acid sequence of SEQ ID NO: 3, which is encoded by a nucleic acid sequence of SEQ ID NO: 4.

5 **[00128]** Additional exemplary PINS nucleotide sequences are represented by the coding sequences of NCBI accession numbers AY899304 (complete CDS, alternatively spliced; SEQ ID NO: 7); NM_000207 (transcript variant 1); NM_001185097 (transcript variant 2); NM_001185098 (transcript variant 3); NM_001291897 (transcript variant 4), and partial sequences thereof. Exemplary PINS amino acid sequences include those encoded by any one
10 of the above PINS nucleic acid sequences.

[00129] Any nucleotide sequence encoding the amino acid sequence of SEQ ID NO: 3, or any nucleotide sequence encoding at least about 20, at least about 30, at least about 40, at least about 50, at least about 60, at least about 70, or at least about 80 consecutive amino acids thereof, or any nucleotide sequence encoding a polypeptide having at least about 60%,
15 at least about 70%, at least about 80%, at least about 90%, at least about 95%, at least about 96%, at least about 97%, at least about 98%, or at least about 99% sequence identity with SEQ ID NO: 3 may be used.

[00130] Additional PINS polypeptides are described, *e.g.*, in UniProtKB - P01308 and links therein. In some examples, the PINS polypeptide is represented by amino acid residues
20 25-110 (numbering according to SEQ ID NO: 5).

[00131] Exemplary GAD (*e.g.*, GAD65) polypeptides include wild-type human GAD65, and polypeptides having at least about 60%, at least about 70%, at least about 80%, at least about 90%, at least about 95%, at least about 96%, at least about 97%, at least about 98%, or at least about 99% sequence identity with such wild-type GAD65. See, *e.g.*, CDS contained
25 in accession number M81882.1.

[00132] Any nucleotide sequence encoding the above amino acid sequence, or any nucleotide sequence encoding at least about 100, at least about 200, at least about 300, at least about 400, or at least about 500 consecutive amino acids thereof, or any nucleotide sequence encoding a polypeptide having at least about 60%, at least about 70%, at least about
30 80%, at least about 90%, at least about 95%, at least about 96%, at least about 97%, at least about 98%, or at least about 99% sequence identity may be used.

[00133] Other exemplary glutamate decarboxylase (*e.g.*, GAD65) sequences are described, *e.g.*, in UniProtKB - Q05329 and links therein. In some example, the GAD polypeptide is a trimmed variant containing less than about 500, less than about 400, or less than about 300 of the wild-type amino acids. Exemplary polypeptide fragments (trimmed GAD65 variants) are described, *e.g.*, in Robert *et al.*, *Benef. Microbes* 2015, 6(4): 591-601, the disclosure of which is incorporated herein by reference in its entirety. In some examples, the trimmed GAD variants are efficiently expressed and secreted by a gram-positive bacterium (*i.e.*, *Lactococcus lactis*). An exemplary trimmed GAD variant is GAD65₃₇₀₋₅₇₅ (amino acid numbering relative to NCBI accession number NP_000809.1).

10 [00134] Other exemplary GAD nucleotide sequences are represented by NCBI accession numbers M81882 (GAD65); M81883 (GAD67); NM_000818 (GAD2 variant 1); and NM_001134366 (GAD2 variant 2); and open reading frames (CDS) contained therein. Exemplary amino acid sequences include sequences encoded by the above nucleotide sequences of accession numbers M81882, M81883, NM_001134366, and NM_000818.

15 [00135] A person of ordinary skill in the art will appreciate that the optimal amount of self-antigen to be delivered to the subject using the methods of the present disclosure varies, *e.g.*, with the type of antigen, the microorganism expressing the antigen, and the genetic construct, *e.g.*, the strength of the promoter used in the genetic construct. Typically, the microorganism will be administered in an amount equivalent to a particular amount of expressed antigen, or in an amount, which generates a desired PK profile for the respective antigen polypeptide in the respective subject. Exemplary daily antigen doses are from about 20 10 fg to about 100 µg of active polypeptide per day. Other exemplary dose ranges are from about 1 pg to about 100 µg per day; or from about 1 ng to about 100 µg per day.

[00136] The above antigen doses may be realized by administering to the subject effective amounts of the microorganism per day, wherein the microorganism is adapted to express a sufficient amount of bioactive polypeptide to realize the desired dose, such as those above. The microorganism secreting the antigen polypeptide may be delivered in a dose of from about 10⁴ colony forming units (cfu) to about 10¹² cfu per day, *e.g.*, from about 10⁶ cfu to about 10¹² cfu per day, or from about 10⁹ cfu to about 10¹² cfu per day.

30 [00137] The amount of secreted antigen polypeptide can be determined based on cfu, for example in accordance with the methods described in Steidler *et al.*, *Science* 2000; 289(5483):1352-1355, or by using ELISA. For example, a particular microorganism may

secrete at least about 1 ng to about 1 µg of active polypeptide per 10⁹ cfu. Based thereon, the skilled person can calculate the range of antigen polypeptide secreted at other cfu doses.

[00138] Each of the above doses/dose ranges may be administered in connection with any dosing regimen as described herein. The daily dose of active polypeptide may be administered in 1, 2, 3, 4, 5, or 6 portions throughout the day. Further the daily doses may be administered for any number of days, with any number of rest periods between administration periods. For example, a dose of from about 0.01 to about 3.0 M IU of IL-10/day/subject may be administered every other day for a total of 6 weeks.

Treating

10 [00139] The terms “treatment”, “treating”, and the like, as used herein means ameliorating or alleviating characteristic symptoms or manifestations of a disease or condition, *e.g.*, T1D. For example, treatment of T1D can result in the restoration or induction of antigen-specific immune tolerance in the subject. In other examples, treatment means arresting auto-immune diabetes, or reversing autoimmune diabetes. As used herein these terms also encompass, preventing or delaying the onset of a disease or condition or of symptoms associated with a disease or condition, including reducing the severity of a disease or condition or symptoms associated therewith prior to affliction with said disease or condition. Such prevention or reduction prior to affliction refers to administration of the compound or composition of the invention to a patient that is not at the time of administration afflicted with the disease or condition. “Preventing” also encompasses preventing the recurrence or relapse-prevention of a disease or condition or of symptoms associated therewith, for instance after a period of improvement. Treatment of a subject “in need thereof” conveys that the subject has a disease or condition, and the therapeutic method of the invention is performed with the intentional purpose of treating the specific disease or condition.

25 *Patient Sub-Populations*

[00140] In some embodiments, the subject being treated using the methods of the present disclosure, has significant (*e.g.*, measurable) residual beta-cell function. Under such circumstances, the subject may maintain disease remission, even after treatment is interrupted or stopped altogether. Newly diagnosed patients often have a certain minimal number of pancreatic islet beta-cells (beta-cells) remaining at the time of diagnosis, so that such patients are able to produce a certain minimal amount of endogenous insulin. Such patient population can benefit particularly well when treated with the compositions and methods of the current

disclosure (e.g., IL-10 and PINS therapy). The treatments described herein can prevent further destruction of beta-cells and may thus induce disease remission. Unexpectedly, the inventors have found that initial beta-cell mass can be important for the efficacy of treatment. However, once a subject's beta-cells are destroyed, such subject may no longer benefit from the described treatment in the same manner.

[00141] Untreated T1D develops over time and becomes progressively worse as beta cells in the pancreas are destroyed. Thus, as the present method can halt disease, it is advantageous to treat subjects as early as possible in the disease progression. Thus, in a related embodiment, the therapeutic method of the invention also includes measuring disease progression prior to therapy, and during therapy.

[00142]

Therapeutically Effective Amount

[00143] As used herein, the term "therapeutically effective amount" refers to an amount of a non-pathogenic microorganism or a composition of the present disclosure that will elicit a desired therapeutic effect or response when administered according to the desired treatment regimen. In some cases, the compounds or compositions are provided in a unit dosage form, for example a tablet or capsule, which contains an amount of the active component equivalent with the therapeutically effective amount when administered once, or multiple times per day.

[00144] A person of ordinary skill in the art will appreciate that a therapeutically effective amount of a recombinant microorganism, which is required to achieve a desired therapeutic effect (e.g., for the effective treatment of T1D), will vary, e.g., depending on the nature of the IL-10 polypeptide expressed by the microorganism, the nature of the antigen polypeptide expressed by the microorganism, the route of administration, and the age, weight, and other characteristics of the recipient.

25 *Mucosa*

[00145] The term "mucosa" or "mucous membrane" is used herein in accordance with its art recognized meaning. The "mucosa" can be any mucosa found in the body, such as oral mucosa, rectal mucosa, gastric mucosa, intestinal mucosa, urethral mucosa, vaginal mucosa, ocular mucosa, buccal mucosa, bronchial or pulmonary mucosa, and nasal or olfactory mucosa.

[00146] The term “mucosal delivery” as used herein is used in accordance with its art recognized meaning, *i.e.*, delivery to the mucosa, *e.g.*, via contacting a composition of the present disclosure with a mucosa. Oral mucosal delivery includes buccal, sublingual and gingival routes of delivery. Accordingly, in some embodiments, “mucosal delivery” includes
5 gastric delivery, intestinal delivery, rectal delivery, buccal delivery, pulmonary delivery, ocular delivery, nasal delivery, vaginal delivery and oral delivery.

[00147] The term “mucosal tolerance” refers to the inhibition of specific immune responsiveness to an antigen in a mammalian subject (*e.g.*, a human patient), after the subject has been exposed to the antigen via the mucosal route. In some cases the mucosal tolerance is
10 systemic tolerance. Low dose oral tolerance is oral tolerance induced by low doses of antigens, and is characterized by active immune suppression, mediated by cyclophosphamide sensitive regulatory T-cells that can transfer tolerance to naive hosts. High dose oral tolerance is oral tolerance induced by high doses of antigens, is insensitive to cyclophosphamide treatment, and proceeds to induction of T cell hyporesponsiveness via anergy and/or deletion
15 of antigen specific T-cells. The difference in sensitivity to cyclophosphamide can be used to make a distinction between low dose and high dose tolerance (Strobel *et al.*, 1983). In some cases, the oral tolerance is low dose oral tolerance as described by Mayer and Shao (2004).

Immuno-Modulating Compound

[00148] The terms “immuno-modulating compound” or immuno-modulator” are used
20 herein in accordance with their art-recognized meaning. The immuno-modulating compound can be any immuno-modulating compound known to a person skilled in the art.

[00149] In some embodiments, the immuno-modulating compound is a tolerance inducing compound. Tolerance induction can be obtained, *e.g.*, by inducing regulatory T-cells, or in an indirect way, *e.g.*, by activation of immature dendritic cells to tolerizing dendritic cells
25 and/or inhibiting Th2 immune response inducing expression of “co-stimulation” factors on mature dendritic cells. Immuno-modulating and immuno-suppressing compounds are known to the person skilled in the art and include, but are not limited to, bacterial metabolites such as spargualin, fungal and streptomycal metabolites such as tacrolimus or ciclosporin, immuno-suppressing cytokines such as IL-4, IL-10, IFN α , TGF β (as selective adjuvant for
30 regulatory T-cells) Flt3L, TSLP and Rank-L (as selective tolerogenic DC inducers), antibodies and/or antagonist such as anti-CD40L, anti-CD25, anti-CD20, anti-IgE, anti-CD3, and proteins, peptides or fusion proteins such as the CTL-41 g or CTLA-4 agonist fusion

protein. In some embodiments, the immuno-modulating compound is an immuno-suppressing compound. In other embodiments, the immuno-suppressing compound is an immuno-suppressing cytokine or antibody. In other embodiments, the immuno-suppressing cytokine is a tolerance-enhancing cytokine or antibody. It will be appreciated by the person skilled in the art that the term “immuno-modulating compound” also includes functional homologues thereof. A functional homologue is a molecule having essentially the same or similar function for the intended purposes, but can differ structurally. In some examples, the immuno-modulating compound is anti-CD3, or a functional homologue thereof.

Microorganisms

10 [00150] The invention relates to the use of at least one microorganism. In some embodiments, the microorganism is a non-pathogenic and non-invasive bacterium. In other embodiments, the microorganism is a non-pathogenic and non-invasive yeast.

[00151] In some embodiments, the microorganism is a yeast strain selected from the group consisting of *Saccharomyces sp.*, *Hansenula sp.*, *Kluyveromyces sp.*, *Schizosaccharomyces sp.*, *Zygosaccharomyces sp.*, *Pichia sp.*, *Monascus sp.*, *Geothchum sp* and *Yarrowia sp.* In some embodiments, the yeast is *Saccharomyces cerevisiae*. In other embodiments, the *S. cerevisiae* is of the subspecies *boulardii*. In one embodiment of the present invention, the recombinant yeast host-vector system is a biologically contained system. Biological containment is known to the person skilled in the art and can be realized by the introduction of an auxotrophic mutation, for example a suicidal auxotrophic mutation such as the *ThyA* mutation, or its equivalents.

25 [00152] In other embodiments of the present invention, the microorganism is a bacterium, such as a non-pathogenic bacterium, *e.g.*, a food grade bacterial strain. In some examples, the non-pathogenic bacterium is a gram-positive bacterium, *e.g.*, a gram-positive food-grade bacterial strain. In some embodiments, the gram-positive food grade bacterial strain is a lactic acid fermenting bacterial strain (*i.e.*, a lactic acid bacterium (LAB) or a Bifidobacterium).

30 [00153] In some embodiments, the lactic acid fermenting bacterial strain is a *Lactococcus*, *Lactobacillus* or *Bifidobacterium* species. As used herein, *Lactococcus* or *Lactobacillus* is not limited to a particular species or subspecies, but meant to include any of the *Lactococcus* or *Lactobacillus* species or subspecies. Exemplary *Lactococcus* species include *Lactococcus garvieae*, *Lactococcus lactis*, *Lactococcus piscium*, *Lactococcus plantarum*, and *Lactococcus*

raffinolactis. In some examples, the *Lactococcus lactis* is *Lactococcus lactis* subsp. *cremoris*, *Lactococcus lactis* subsp. *hordniae*, or *Lactococcus lactis* subsp. *Lactis*.

[00154] Exemplary *Lactobacillus* species include *Lactobacillus acetotolerans*,
Lactobacillus acidophilus, *Lactobacillus agilis*, *Lactobacillus algidus*, *Lactobacillus*
5 *alimentarius*, *Lactobacillus amylolyticus*, *Lactobacillus amylophilus*, *Lactobacillus*
amylovorus, *Lactobacillus animalis*, *Lactobacillus aviarius*, *Lactobacillus aviarius* subsp.
araffinosus, *Lactobacillus aviarius* subsp. *aviarius*, *Lactobacillus bavaricus*, *Lactobacillus*
bifermentans, *Lactobacillus brevis*, *Lactobacillus buchneri*, *Lactobacillus bulgaricus*,
Lactobacillus carnis, *Lactobacillus casei*, *Lactobacillus casei* subsp. *alactosus*, *Lactobacillus*
10 *casei* subsp. *casei*, *Lactobacillus casei* subsp. *pseudopiantarum*, *Lactobacillus casei* subsp.
rhamnosus, *Lactobacillus casei* subsp. *tolerans*, *Lactobacillus catenaformis*, *Lactobacillus*
cellobiosus, *Lactobacillus collinoides*, *Lactobacillus confusus*, *Lactobacillus coryniformis*,
Lactobacillus coryniformis subsp. *coryniformis*, *Lactobacillus coryniformis* subsp. *torquens*,
Lactobacillus crispatus, *Lactobacillus curvatus*, *Lactobacillus curvatus* subsp. *curvatus*,
15 *Lactobacillus curvatus* subsp. *melibiosus*, *Lactobacillus delbrueckii*, *Lactobacillus*
delbrueckii subsp. *bulgaricus*, *Lactobacillus delbrueckii* subsp. *delbrueckii*, *Lactobacillus*
delbrueckii subsp. *lactis*, *Lactobacillus divergens*, *Lactobacillus farciminis*, *Lactobacillus*
fermentum, *Lactobacillus fornicalis*, *Lactobacillus fructivorans*, *Lactobacillus fructosus*,
Lactobacillus gallinarum, *Lactobacillus gasseri*, *Lactobacillus graminis*, *Lactobacillus*
20 *halotolerans*, *Lactobacillus hamsteri*, *Lactobacillus helveticus*, *Lactobacillus heterohiochii*,
Lactobacillus hilgardii, *Lactobacillus homohiochii*, *Lactobacillus iners*, *Lactobacillus*
intestinalis, *Lactobacillus jensenii*, *Lactobacillus johnsonii*, *Lactobacillus kandleri*,
Lactobacillus kefir, *Lactobacillus kefiranoferens*, *Lactobacillus kefirgranum*, *Lactobacillus*
kunkeei, *Lactobacillus lactis*, *Lactobacillus leichmannii*, *Lactobacillus lindneri*,
25 *Lactobacillus malefermentans*, *Lactobacillus mali*, *Lactobacillus maltaromicus*,
Lactobacillus manihotivorans, *Lactobacillus minor*, *Lactobacillus minutus*, *Lactobacillus*
mucosae, *Lactobacillus murinus*, *Lactobacillus nagelii*, *Lactobacillus oris*, *Lactobacillus*
panis, *Lactobacillus parabuchneri*, *Lactobacillus paracasei*, *Lactobacillus paracasei* subsp.
paracasei, *Lactobacillus paracasei* subsp. *tolerans*, *Lactobacillus parakefir*, *Lactobacillus*
30 *paralimentarius*, *Lactobacillus paraplantarum*, *Lactobacillus pentosus*, *Lactobacillus*
perolens, *Lactobacillus piscicola*, *Lactobacillus plantarum*, *Lactobacillus pontis*,
Lactobacillus reuteri, *Lactobacillus rhamnosus*, *Lactobacillus rimae*, *Lactobacillus rogosae*,
Lactobacillus ruminis, *Lactobacillus sakei*, *Lactobacillus sakei* subsp. *camosus*,

Lactobacillus sakei subsp. *sakei*, *Lactobacillus salivarius*, *Lactobacillus salivarius* subsp. *salicinius*, *Lactobacillus salivarius* subsp. *salivarius*, *Lactobacillus sanfranciscensis*, *Lactobacillus sharpeae*, *Lactobacillus suebicus*, *Lactobacillus trichodes*, *Lactobacillus uli*, *Lactobacillus vaccinostercus*, *Lactobacillus vaginalis*, *Lactobacillus viridescens*,
5 *Lactobacillus vitulinus*, *Lactobacillus xylosus*, *Lactobacillus yamanashiensis*, *Lactobacillus yamanashiensis* subsp. *mali*, *Lactobacillus yamanashiensis* subsp. *Yamanashiensis*, *Lactobacillus zeae*, *Bifidobacterium adolescentis*, *Bifidobacterium angulatum*, *Bifidobacterium bifidum*, *Bifidobacterium breve*, *Bifidobacterium catenulatum*, *Bifidobacterium longum*, and *Bifidobacterium infantis*. In some examples, the LAB is
10 *Lactococcus lactis* (LL).

[00155] In further examples, the bacterium is selected from the group consisting of *Enterococcus alcedinis*, *Enterococcus aquimarinus*, *Enterococcus asini*, *Enterococcus avium*, *Enterococcus caccae*, *Enterococcus camelliae*, *Enterococcus canintestini*, *Enterococcus canis*, *Enterococcus casseliflavus*, *Enterococcus cecorum*, *Enterococcus columbae*,
15 *Enterococcus devriesei*, *Enterococcus diestrammenae*, *Enterococcus dispar*, *Enterococcus durans*, *Enterococcus eurekensis*, *Enterococcus faecalis*, *Enterococcus faecium*, *Enterococcus gallinarum*, *Enterococcus gilvus*, *Enterococcus haemoperoxidus*, *Enterococcus hermannienseis*, *Enterococcus hirae*, *Enterococcus italicus*, *Enterococcus lactis*, *Enterococcus lemanii*, *Enterococcus malodoratus*, *Enterococcus moraviensis*, *Enterococcus mundtii*,
20 *Enterococcus olivae*, *Enterococcus pallens*, *Enterococcus phoeniculicola*, *Enterococcus plantarum*, *Enterococcus pseudoavium*, *Enterococcus quebecensis*, *Enterococcus raffinokus*, *Enterococcus ratti*, *Enterococcus rivorum*, *Enterococcus rotai*, *Enterococcus saccharolyticus*, *Enterococcus silesiacus*, *Enterococcus solitarius*, *Enterococcus sulfureus*, *Enterococcus termitis*, *Enterococcus thailandicus*, *Enterococcus ureasiticus*, *Enterococcus ureilyticus*,
25 *Enterococcus viikkiensis*, *Enterococcus villorum*, and *Enterococcus xiangfangensis*,

[00156] In further examples, the bacterium is selected from the group consisting of *Streptococcus agalactiae*, *Streptococcus anginosus*, *Streptococcus bovis*, *Streptococcus canis*, *Streptococcus constellatus*, *Streptococcus dysgalactiae*, *Streptococcus equinus*,
30 *Streptococcus iniae*, *Streptococcus intermedius*, *Streptococcus milleri*, *Streptococcus mitis*, *Streptococcus mutans*, *Streptococcus oralis*, *Streptococcus parasanguinis*, *Streptococcus peroris*, *Streptococcus pneumoniae*, *Streptococcus pseudopneumoniae*, *Streptococcus pyogenes*, *Streptococcus ratti*, *Streptococcus salivarius*, *Streptococcus tigurinus*,

Streptococcus thermophilus, *Streptococcus sanguinis*, *Streptococcus sobrinus*, *Streptococcus suis*, *Streptococcus uberis*, *Streptococcus vestibularis*, *Streptococcus viridans*, and *Streptococcus zooepidemicus*.

[00157] In a particular aspect of the present invention, the gram-positive food grade
5 bacterial strain is *Lactococcus lactis* or any of its subspecies, including *Lactococcus lactis*
subsp. Cremoris, *Lactococcus lactis subsp. Hordniae*, and *Lactococcus lactis subsp. Lactis*.
In another aspect of the present invention, the recombinant gram-positive bacterial strains is a
biologically contained system, such as the plasmid free *Lactococcus lactis* strain MG1363,
that lost the ability of normal growth and acid production in milk (Gasson, M.J. (1983) *J.*
10 *Bacteriol.* 154:1-9); or the threonine- and pyrimidine-auxotroph derivative *L. lactis* strains
(Sorensen *et al.* (2000) *Appl. Environ. Microbiol.* 66:1253-1258; Glenting *et al.* (2002)
68:5051-5056).

[00158] In one embodiment of the present invention, the recombinant bacterial host-vector
system is a biologically contained system. Biological containment is known to the person
15 skilled in the art and can be realized by the introduction of an auxotrophic mutation, for
example a suicidal auxotrophic mutation such as the *ThyA* mutation, or its equivalents,
debilitating DNA synthesis. Other examples of auxotrophic mutations can debilitate RNA,
cell wall or protein synthesis. Alternatively, the biological containment can be realized at the
level of the plasmid carrying the gene encoding the IL-10 polypeptide or IL-10 variant, such
20 as, for example, by using an unstable episomal construct, which is lost after a few
generations. Several levels of containment, such as plasmid instability and auxotrophy, can
be combined to ensure a high level of containment, if desired.

Constructs

[00159] In the present invention, the microorganism (*e.g.*, the non-pathogenic gram-
25 positive bacterium) delivers the IL-10 polypeptide and the T1D-specific antigen (*e.g.*, PINS)
at the intended site, *i.e.*, the mucosa. For example, the microorganism (*e.g.*, LAB) expresses
the IL-10 polypeptide, after which the IL-10 polypeptide is secreted (if a secreted form of IL-
10 is used). Hence, in a particular embodiment the microorganism (*e.g.*, LAB), such as *L.*
lactis, expresses IL-10 and PINS at the site of an intended mucosa, *e.g.*, in the gastrointestinal
30 tract.

[00160] Use of an operon enables expression of the IL-10 polypeptide and T1D-specific
antigen polypeptide (*e.g.*, PINS) to be coordinated. Polycistronic expression systems in

bacterial host cells are described, *e.g.*, in U.S. Patent Application No. 2014/0105863 to Vanden-Broucke *et al.*, which is incorporated herein by reference in its entirety.

[00161] In an embodiment the present invention relates to stably transfected microorganisms, *i.e.*, microorganisms in which the gene coding for the IL-10 polypeptide and the T1D-specific antigen (*e.g.*, PINS) gene has been integrated into the host cell's genome. Techniques for establishing stably transfected microorganisms are known in the art. For instance, the IL-10 polypeptide and the T1D-specific antigen (*e.g.*, PINS) gene may be cloned into the host's genome, *e.g.* in the chromosome, via homologous recombination. In some embodiments, an essential gene of the host is disrupted by the homologous recombination event, such as deletion of the gene, one or more amino acid substitutions leading to an inactive form of the protein encoded by the essential gene, or to a frameshift mutation resulting in a truncated form of the protein encoded by the essential gene. In an embodiment, the essential gene is the *thyA* gene. A preferred technique is described, *e.g.*, in WO 02/090551, which is incorporated herein by reference in its entirety. The plasmid may be a self-replicating, for example carrying one or more genes of interest and one or more resistance markers. Then, the transforming plasmid can be any plasmid, as long as it cannot complement the disrupted essential gene, *e.g.*, *thyA* gene. Alternatively, the plasmid is an integrative plasmid. In the latter case, the integrative plasmid itself may be used to disrupt the essential gene, by causing integration at the locus of the essential gene, *e.g.*, *thyA* site, because of which the function of the essential gene, *e.g.*, the *thyA* gene, is disrupted. In some cases, the essential gene, such as the *thyA* gene, is replaced by double homologous recombination by a cassette comprising the gene or genes of interest, flanked by targeting sequences that target the insertion to the essential gene, such as the *thyA* target site. It will be appreciated that that these targeting sequences are sufficiently long and sufficiently homologous to enable integration of the gene of interest into the target site. In some examples, an IL-10 expression cassette of the present disclosure is integrated at the *thyA* locus.

[00162] The genetic construct encoding the IL-10 polypeptide and the T1D-specific antigen (*e.g.*, PINS) may be integrated into the microbial genomic DNA, *e.g.*, bacterial or yeast chromosome, *e.g.*, *Lactococcus* chromosome. In the latter case, a single or multiple copies of the nucleic acid may be integrated; the integration may occur at a random site of the chromosome or, as described above, at a predetermined site thereof, for example at a

predetermined site, such as, in a non-limiting example, in the *thyA* locus of *Lactococcus*, *e.g.*, *Lactococcus lactis*.

[00163] Hence, in an embodiment, the genetic construct encoding the IL-10 polypeptide and the T1D-specific antigen (*e.g.*, PINS) may further comprise sequences configured to effect insertion of the genetic construct into the genome, *e.g.*, a chromosome, of a host cell.

[00164] In some examples, insertion of the genetic construct into particular sites within a genome, *e.g.*, chromosome, of a host cell may be facilitated by homologous recombination. For instance, the genetic construct the invention may comprise one or more regions of homology to the said site of integration within the genome *e.g.*, a chromosome, of the host cell. The sequence at the said genome, *e.g.*, chromosome, site may be natural, *i.e.*, as occurring in nature, or may be an exogenous sequence introduced by previous genetic engineering. For instance, the region(s) of homology may be at least 50 bp, 100 bp, 200 bp, 300 bp, 400 bp, 500 bp, 600 bp, 700 bp, 800 bp, 900 bp, 1000 bp, or more.

[00165] In one example, two regions of homology may be included, one flanking each side of the relevant expression units present in the genetic construct of the invention. Such configuration may advantageously insert the relevant sequences, *i.e.*, at least the ones encoding and effecting the expression of the antigen of interest, in host cells. Ways of performing homologous recombination, especially in bacterial hosts, and selecting for recombinants, are generally known in the art.

[00166] Transformation methods of microorganisms are known to the person skilled in the art, such as for instance protoplast transformation and electroporation.

[00167] A high degree of expression can be achieved by using homologous expression and/or secretion signals on the expression vectors present in the microorganism, *e.g.*, *L. lactis*. Expression signals will be apparent to the person skilled in the art. The expression vector can be optimized for expression depending on the microorganism, *e.g.*, *L. lactis*, it is incorporated in. For instance, specific expression vectors that gave sufficient levels of expression in *Lactococcus*, *Lactobacillus lactis*, *casei* and *plantarum* are known. Moreover, systems are known which have been developed for the expression of heterologous antigens in the non-pathogenic, non-colonizing, non-invasive food-grade bacterium *Lactococcus lactis* (see UK patent GB2278358B, which is incorporated herein by reference). A particularly preferred construct according to the invention comprises the multi-copy expression vector described in PCT/NL95/00135 (WO-A-96/32487), in which the nucleotide sequence

encoding the IL-10 polypeptide and/or the T1D-specific antigen (*e.g.*, PINS) has been incorporated. Such a construct is particularly suitable for expression of a desired antigen in a lactic acid bacterium, in particular in a *Lactobacillus*, at a high level of expression, and also can be used advantageously to direct the expressed product to the surface of the bacterial cell.

5 The constructs (*e.g.*, of PCT/NL95/00135) may be characterized in that the nucleic acid sequence encoding the IL-10 polypeptide and/or T1D-specific antigen (*e.g.*, PINS) is preceded by a 5' non-translated nucleic acid sequence comprising at least the minimal sequence required for ribosome recognition and RNA stabilization. This can be followed by a translation initiation codon which may be (immediately) followed by a fragment of at least 5

10 codons of the 5' terminal part of the translated nucleic acid sequence of a gene of a lactic acid bacterium or a structural or functional equivalent of the fragment. The fragment may also be controlled by the promoter. The contents of PCT/NL95/00135, including the differing embodiments disclosed therein, and all other documents mentioned in this specification, are incorporated herein by reference. One aspect of the present invention provides a method

15 which permits the high level regulated expression of heterologous genes in the host and the coupling of expression to secretion. In another embodiment, the T7 bacteriophage RNA polymerase and its cognate promoter are used to develop a powerful expression system according to WO 93/17117, which is incorporated herein by reference. In one embodiment, the expression plasmid is derived from pT1 NX (GenBank: HM585371.1).

20 **[00168]** A promoter employed in accordance with the present invention is in some cases expressed constitutively in the bacterium. The use of a constitutive promoter avoids the need to supply an inducer or other regulatory signal for expression to take place. In some cases, the promoter directs expression at a level at which the bacterial host cell remains viable, *i.e.*, retains some metabolic activity, even if growth is not maintained. Advantageously then, such

25 expression may be at a low level. For example, where the expression product accumulates intracellularly, the level of expression may lead to accumulation of the expression product at less than about 10% of cellular protein, about or less than about 5%, for example about 1-3%. The promoter may be homologous to the bacterium employed, *i.e.*, one found in that bacterium in nature. For example, a Lactococcal promoter may be used in a *Lactococcus*. A

30 preferred promoter for use in *Lactococcus lactis* (or other *Lactococci*) is "P1" derived from the chromosome of *Lactococcus lactis* (Waterfield, N R, Lepage, R W F, Wilson, P W, *et al.* (1995). "The isolation of lactococcal promoters and their use in investigating bacterial luciferase synthesis in *Lactococcus lactis*" *Gene* 165(1):9-15). Other examples of a promoter

include, the *usp45* promoter, the *gapB* promoter, and the *hllA* promoter. Other useful promoters are described in U.S. Patent 8,759,088 to Steidler *et al.*, and in U.S. Patent Application No. 2014/0105863 to Vanden-Broucke *et al.*, the disclosures of which are incorporated herein by reference in their entirety. In some examples, a nucleic acid encoding an IL-10 polypeptide is placed under an *hllA* promoter.

[00169] The nucleic acid construct or constructs may comprise a nucleic acid encoding a secretory signal sequence. Thus, in some embodiments the nucleic acid encoding IL-10 and/or the T1D-specific antigen (*e.g.*, PINS) may provide for secretion of the polypeptides, *e.g.*, by appropriately coupling a nucleic acid sequence encoding a signal sequence to the nucleic acid sequence encoding the polypeptide). Ability of a bacterium harboring the nucleic acid to secrete the antigen may be tested *in vitro* in culture conditions which maintain viability of the organism. Preferred secretory signal sequences include any of those with activity in Gram positive organisms such as *Bacillus*, *Clostridium* and *Lactobacillus*. Such sequences may include the α -amylase secretion leader of *Bacillus amyloliquetaciens* or the secretion leader of the *Staphylokinase* enzyme secreted by some strains of *Staphylococcus*, which is known to function in both Gram-positive and Gram-negative hosts (*see* "Gene Expression Using Bacillus," Rapoport (1990) *Current Opinion in Biotechnology* 1:21-27), or leader sequences from numerous other *Bacillus* enzymes or S-layer proteins (*see* pp 341-344 of Harwood and Cutting, "Molecular Biological Methods for *Bacillus*," John Wiley & Co. 1990). In one embodiment, said secretion signal is derived from *usp45* (Van Asseldonk *et al.* (1993) *Mol. Gen. Genet.* 240:428-434). Such secretion leader is referred to herein, *e.g.*, as SSusp45. In some embodiments, the IL-10 polypeptide is constitutively secreted using SSusp45. In other examples, the PINS polypeptide is secreted using SSusp45. In yet other examples, both the IL-10 polypeptide and the PINS polypeptide are secreted using SSusp45.

[00170] A person of ordinary skill in the art will appreciate that the optimal amount of IL-10 and PINS to be delivered to the subject using the methods of the present disclosure varies, *e.g.*, with the microorganism expressing the IL-10 polypeptide and the PINS polypeptide, and the genetic constructs, *e.g.*, the strength of the promoter used in the genetic constructs. Typically, the microorganism will be administered in an amount equivalent to a particular amount of expressed IL-10 polypeptide and PINS polypeptide, or in an amount which generates a desired PK profile for the respective IL-10 polypeptide or PINS polypeptide in the respective subject. Exemplary daily IL-10 polypeptide or PINS polypeptide doses are

from about 10 fg to about 100 µg of active polypeptide per day. Other exemplary dose ranges are from about 1 pg to about 100 µg per day; or from about 1 ng to about 100 µg per day.

[00171] The above doses may be realized by administering to the subject effective amounts of the microorganism per day, wherein the microorganism is adapted to express a sufficient amount of IL-10 and a T1D-specific antigen (*e.g.*, PINS) to realize the desired dose, such as those above. The microorganism secreting the IL-10 polypeptide and the T1D-specific antigen (*e.g.*, PINS polypeptide) may be delivered in a dose of from about 10^4 colony forming units (cfu) to about 10^{12} cfu per day, in particular from about 10^6 cfu to about 10^{12} cfu per day, more in particular from about 10^9 cfu to about 10^{12} cfu per day. The amount of secreted IL-10 and T1D-specific antigen (*e.g.*, PINS polypeptide) can be determined based on cfu, for example in accordance with the methods described in Steidler *et al.*, *Science* 2000; 289(5483):1352-1355, or by using ELISA. For example, a particular microorganism may secrete at least about 1 ng to about 1 µg IL-10 per 10^9 cfu. Based thereon, the skilled person can calculate the range of IL-10 polypeptide secreted at other cfu doses.

[00172] Each of the above doses/dose ranges may be administered in connection with any dosing regimen as described herein. The daily dose may be administered in 1, 2, 3, 4, 5, or 6 portions throughout the day. Further the daily doses may be administered for any number of days, with any number of rest periods between administration periods. For example, the subject may be administered the microorganism at a dose equivalent to about 0.01 to about 3 M IU of IL-10/day or every other day, for a period of at least about 1 week, at least about 2 weeks, at least about 3 weeks, at least about 4 weeks, at least about 5 weeks, or at least about 6 weeks. In some examples, the subject is administered the microorganism at a dose equivalent to about 0.1 to about 5 MIU/day, or about 0.3 to about 3 MIU, *e.g.*, for about 5 days, about 7 days, or about 14 days. Exemplary doses are described, *e.g.*, in Hartemann *et al.*, *Lancet Diabetes Endocrinol.* 2013, 1(4): 295-305, the disclosure of which is incorporated herein by reference in its entirety.

Formulations and Regimens

[00173] In some methods of the present disclosure, the IL-10 polypeptide and the T1D-specific antigen (*e.g.*, PINS) are administered (delivered) to a subject (*e.g.*, a human T1D-patient) using a microorganism (*e.g.*, LAB) producing both the IL-10 polypeptide and the T1D-specific antigen (*e.g.*, PINS) polypeptide.

[00174] In some embodiments, the microorganism (*e.g.*, LAB), optionally contained in a composition (*e.g.*, a pharmaceutical composition) of the present disclosure or a unit dosage form of the present disclosure, will be administered, once, twice, three, four, five, or six times daily, *e.g.*, using an oral formulation. In some embodiments, the microorganism is administered every day, every other day, once per week, twice per week, three times per week, or four times per week. In other embodiments, treatment occurs once every two weeks. In other embodiments, treatment occurs once every three weeks. In other embodiments, treatment occurs once per month.

[00175] The duration of a treatment cycle is, for example, 7 days to the subject's lifetime, as needed to treat or reverse T1D, or prevent relapse. In some embodiments, a treatment cycle lasts for about 30 days to about 2 years. In other embodiments, the subject will have a treatment cycle that lasts from 30 days to 1.5 years. In other embodiments, the subject will have a treatment cycle that lasts from 30 days to 1 year. In other embodiments, the subject will have a treatment cycle that lasts from 30 days to 11 months. In other embodiments, the subject will have a treatment cycle that lasts from 30 days to 10 months. In other embodiments, the subject will have a treatment cycle that lasts from 30 days to 9 months. In other embodiments, the subject will have a treatment cycle that lasts from 30 days to 8 months. In other embodiments, the subject will have a treatment cycle that lasts from 30 days to 7 months. In other embodiments, the subject will have a treatment cycle that lasts from 30 days to 6 months. In other embodiments, the subject will have a treatment cycle that lasts from 30 days to 5 months. In other embodiments, the subject will have a treatment cycle that lasts from 30 days to 4 months. In other embodiments, the subject will have a treatment cycle that lasts from 30 days to 3 months. In other embodiments, the subject will have a treatment cycle that lasts from 30 days to 2 months.

[00176] In further embodiments, the treatment cycle will be based on the level of markers that track the progress of disease, including glycemic index, insulin autoantibody (IAA) levels, fragment C levels, and insulinitis. Preferably, the subject is at early onset diabetes. A subject may also be assessed for the level of Treg cells that suppress the immune response to beta cells. In an exemplary embodiment, the subject is treated at least until there is no further disease progression, preferably until there is a return of normoglycemia. The patient may be treated for an additional period to ensure a population of Treg cells that suppress and reverse disease. A subject may also be monitored and treated at the first appearance of any indicia of reemergent disease.

[00177] Daily maintenance doses can be given for a period clinically desirable in the subject, for example from 1 day up to several years (*e.g.* for the subject's entire remaining life); for example from about (2, 3 or 5 days, 1 or 2 weeks, or 1 month) upwards and/or for example up to about (5 years, 1 year, 6 months, 1 month, 1 week, or 3 or 5 days).

5 Administration of the daily maintenance dose for about 3 to about 5 days or for about 1 week to about 1 year is typical. Nevertheless, unit doses should for example be administered from twice daily to once every two weeks until a therapeutic effect is observed.

[00178] The microorganisms producing the IL-10 polypeptide and the T1D-specific antigen (*e.g.*, PINS) polypeptide may be administered to the subject in mono- or combination
10 therapy (*e.g.*, using a co-therapeutic regimen) for the treatment of T1D. "The term "co-therapy," "co-therapeutic" or variation thereof refers to a treatment regimen, in which the subject is administered at least one additional therapeutically active agent, such as an additional immuno-modulating compound. Thus, in some embodiments, the compositions of the present disclosure include additional therapeutically active agents. In some embodiments,
15 the compositions of the present disclosure contain at least one additional immuno-modulating substance, such as antibodies (*e.g.*, anti-CD3 antibodies). In some examples, the methods of the present disclosure further include administering to the subject (*e.g.*, a human patient) an additional immuno-modulating substance, such as antibodies (*e.g.*, anti-CD3 antibodies).

Pharmaceutical Compositions and Carriers

20 [00179] The microorganism (*e.g.*, bacteria, such as LAB described herein) may be administered in pure form, combined with other active ingredients, and/or combined with pharmaceutically acceptable (*i.e.*, nontoxic) excipients or carriers. The term "pharmaceutically acceptable" is used herein in accordance with its art-recognized meaning and refers to carriers that are compatible with the other ingredients of a pharmaceutical
25 composition, and are not deleterious to the recipient thereof.

[00180] The compositions of the present disclosure can be prepared in any known or otherwise effective dosage or product form suitable for delivery of the microorganism (*e.g.*, bacteria) to the mucosa, which would include pharmaceutical compositions and dosage forms as well as nutritional product forms.

30 [00181] In some embodiments, the pharmaceutical composition (*i.e.*, formulation) is an oral pharmaceutical composition. In some examples according to this embodiment, the formulation or pharmaceutical composition comprises the non-pathogenic microorganism in

a dried form (*e.g.*, dry-powder form; *e.g.*, freeze-dried form) or in compacted form thereof, optionally in combination with other dry carriers. Oral formulations will generally include an inert diluent carrier or an edible carrier.

[00182] In some examples, the oral formulation comprises a coating or utilizes an encapsulation strategy, which facilitates the delivery of the formulation into the intestinal tract, and/or allows the microorganism be released and hydrated in the intestinal tract (*e.g.*, the ileum, small intestine, or the colon). Once the microorganism is released from the formulation and sufficiently hydrated, it begins expressing the bioactive polypeptides, which are subsequently released into the surroundings, or expressed on the surface of the microorganism. Such coating and encapsulation strategies (*i.e.*, delayed-release strategies) are known to those of skill in the art. *See, e.g.*, U.S. 5,972,685; WO 2000/18377; and WO 2000/22909, the disclosures of which are incorporated herein by reference in their entirety.

[00183] In some embodiments, the disclosure provides a pharmaceutical composition comprising the microorganism (*e.g.*, the non-pathogenic bacteria) in a lyophilized or freeze dried form, optionally in conjunction with other components, such as dextrans, sodium glutamate, and polyols. Exemplary freeze dried compositions are described, *e.g.*, in U.S. Patent Application No. 2012/0039853 to Corveleyn *et al.*, the disclosure of which is incorporated herein by reference in its entirety. Exemplary formulations comprise freeze-dried bacteria (*e.g.*, a therapeutically effective amount of the bacteria) and a pharmaceutically acceptable carrier. Freeze-dried bacteria may be prepared in the form of capsules, tablets, granulates and powders, each of which may be administered orally. Alternatively, freeze-dried bacteria may be prepared as aqueous suspensions in suitable media, or lyophilized bacteria may be suspended in a suitable medium, such as a drink, just prior to use. Such composition may additionally contain a stabilizing agent useful to maintain a stable suspension, *e.g.*, without precipitation, aggregation, or floating of the bacterial biomass.

[00184] For oral administration, the formulation may be a gastro-resistant oral dosage form. For example, the oral dosage form (*e.g.*, capsules, tablets, pellets, micro-pellets, granulates, and the like) may be coated with a thin layer of excipient (usually polymers, cellulosic derivatives and/or lipophilic materials) that resists dissolution or disruption in the stomach, but not in the intestine, thereby allowing transit through the stomach in favor of disintegration, dissolution and absorption in the intestine (*e.g.*, the small intestine, or the colon).

[00185] In some examples, oral formulations may include compounds providing controlled release, sustained release, or prolonged release of the microorganism, and thereby provide controlled release of the desired protein encoded therein. These dosage forms (*e.g.*, tablets or capsules) typically contain conventional and well known excipients, such as lipophilic, polymeric, cellulosic, insoluble, and/or swellable excipients. Controlled release formulations may also be used for any other delivery sites including intestinal, colon, bioadhesion or sublingual delivery (*i.e.*, dental mucosal delivery) and bronchial delivery. When the compositions of the invention are to be administered rectally or vaginally, pharmaceutical formulations may include suppositories and creams. In this instance, the host cells are suspended in a mixture of common excipients also including lipids. Each of the aforementioned formulations are well known in the art and are described, for example, in the following references: Hansel *et al.* (1990, Pharmaceutical dosage forms and drug delivery systems, 5th edition, William and Wilkins); Chien 1992, Novel drug delivery system, 2nd edition, M. Dekker); Prescott *et al.* (1989, Novel drug delivery, J. Wiley & Sons); Gazzaniga *et al.*, (1994, Oral delayed release system for colonic specific delivery, *Int. J. Pharm.* 108:77-83).

[00186] In some embodiments, the oral formulation includes compounds that can enhance mucosal delivery and/or mucosal uptake of the bioactive polypeptides expressed by the microorganism. In other examples, the formulation includes compounds, which enhance the viability of the microorganism within the formulation, and/or once released.

[00187] The bacteria of the invention can be suspended in a pharmaceutical formulation for administration to the human or animal having the disease to be treated. Such pharmaceutical formulations include but are not limited to live gram-positive bacteria and a medium suitable for administration. The bacteria may be lyophilized in the presence of common excipients such as lactose, other sugars, alkaline and/or alkali earth stearate, carbonate and/or sulphate (*e.g.*, magnesium stearate, sodium carbonate and sodium sulphate), kaolin, silica, flavorants and aromas. Bacteria so-lyophilized may be prepared in the form of capsules, tablets, granulates and powders (*e.g.*, a mouth rinse powder), each of which may be administered by the oral route. Alternatively, some gram-positive bacteria may be prepared as aqueous suspensions in suitable media, or lyophilized bacteria may be suspended in a suitable medium just prior to use, such medium including the excipients referred to herein and other excipients such as glucose, glycine and sodium saccharinate.

[00188] In some examples, the microorganism is locally delivered to the gastrointestinal tract of the subject using any suitable method. For example, microsphere delivery systems could be employed to enhance delivery to the gut. Microsphere delivery systems include microparticles having a coating that provides localized release into the gastrointestinal tract of the subject (e.g., controlled release formulations such as enteric-coated formulations and colonic formulations).

[00189] For oral administration, gastroresistant oral dosage forms may be formulated, which dosage forms may also include compounds providing controlled release of the gram-positive bacteria and thereby provide controlled release of the desired protein encoded therein (e.g., IL-10). For example, the oral dosage form (including capsules, tablets, pellets, granulates, powders) may be coated with a thin layer of excipient (e.g., polymers, cellulosic derivatives and/or lipophilic materials) that resists dissolution or disruption in the stomach, but not in the intestine, thereby allowing transit through the stomach in favor of disintegration, dissolution and absorption in the intestine.

[00190] The oral dosage form may be designed to allow slow release of the gram-positive bacteria and of the produced exogenous proteins, for instance as controlled release, sustained release, prolonged release, sustained action tablets or capsules. These dosage forms usually contain conventional and well-known excipients, such as lipophilic, polymeric, cellulosic, insoluble, and/or swellable excipients. Such formulations are well-known in the art and are described, for example, in the following references: Hansel *et al.*, Pharmaceutical dosage forms and drug delivery systems, 5th edition, William and Wilkins, 1990; Chien 1992, Novel drug delivery system, 2nd edition, M. Dekker; Prescott *et al.*, Novel drug delivery, J. Wiley & Sons, 1989; and Gazzaniga *et al.*, *Int. J. Pharm.* 108: 77-83 (1994).

[00191] The pharmaceutical dosage form (e.g. capsule) may be coated with pH-dependent Eudragit polymers to obtain gastric juice resistance and for the intended delivery at the terminal ileum and colon, where the polymers dissolve at pH 6.5. By using other Eudragit polymers or a different ratio between the polymers, the delayed release profile could be adjusted, to release the bacteria for example in the duodenum or jejunum.

[00192] Pharmaceutical compositions contain at least one pharmaceutically acceptable carrier. Non-limiting examples of suitable excipients, diluents, and carriers include preservatives, inorganic salts, acids, bases, buffers, nutrients, vitamins, fillers and extenders such as starch, sugars, mannitol, and silicic derivatives; binding agents such as carboxymethyl cellulose and other cellulose derivatives, alginates, gelatin, and polyvinyl

pyrrolidone; moisturizing agents such as glycerol/ disintegrating agents such as calcium carbonate and sodium bicarbonate; agents for retarding dissolution such as paraffin; resorption accelerators such as quaternary ammonium compounds; surface active agents such as acetyl alcohol, glycerol monostearate; adsorptive carriers such as kaolin and bentonite ;
5 carriers such as propylene glycol and ethyl alcohol, and lubricants such as talc, calcium and magnesium stearate, and solid polyethyl glycols.

[00193] Pharmaceutically compatible binding agents, and/or adjuvant materials can be included as part of the composition. Tablets, pills, capsules, troches and the like can contain any of the following ingredients, or compounds of a similar nature: a binder such as
10 microcrystalline cellulose, gum tragacanth or gelatin; an excipient such as starch or lactose, a dispersing agent such as alginic acid, Primogel, or corn starch; a lubricant such as magnesium stearate; a glidant such as colloidal silicon dioxide; a sweetening agent such as sucrose or saccharin; or a flavoring agent such as peppermint, methyl salicylate, or orange flavoring. When the dosage unit form is a capsule, it can contain, in addition to material of the above
15 type, a liquid carrier such as a fatty oil. In addition, dosage unit forms can contain various other materials that modify the physical form of the dosage unit, for example, coatings of sugar, shellac, or enteric agents. Further, a syrup may contain, in addition to the active compounds, sucrose as a sweetening agent and certain preservatives, dyes, colorings, and flavorings. It will be appreciated that the form and character of the pharmaceutically
20 acceptable carrier is dictated by the amount of active ingredient with which it is to be combined, the route of administration and other well-known variables. The carrier(s) must be “acceptable” in the sense of being compatible with the other ingredients of the formulation and not deleterious to the recipient thereof.

[00194] Alternative preparations for administration include sterile aqueous or nonaqueous
25 solutions, suspensions, and emulsions. Examples of non-aqueous solvents are dimethylsulfoxide, alcohols, propylene glycol, polyethylene glycol, vegetable oils such as olive oil and injectable organic esters such as ethyl oleate. Aqueous carriers include mixtures of alcohols and water, buffered media, and saline. Intravenous vehicles include fluid and nutrient replenishers, electrolyte replenishers, such as those based on Ringer’s dextrose, and
30 the like. Preservatives and other additives may also be present such as, for example, antimicrobials, anti-oxidants, chelating agents, inert gases, and the like. Various liquid formulations are possible for these delivery methods, including saline, alcohol, DMSO, and water based solutions.

[00195] Oral aqueous formulations include excipients, such as pharmaceutical grades of mannitol, lactose, starch, magnesium stearate, sodium saccharine, cellulose, magnesium carbonate and/or the like. These compositions take the form of solutions such as mouthwashes and mouthrinses, further comprising an aqueous carrier such as for example water, alcoholic/aqueous solutions, saline solutions, parenteral vehicles such as sodium chloride, Ringer's dextrose, and the like.

[00196] Aqueous mouthwash formulations are well-known to those skilled in the art. Formulations pertaining to mouthwashes and oral rinses are discussed in detail, for example, in U.S. Patent 6,387,352, U.S. Patent 6,348,187, U.S. Patent 6,171,611, U.S. Patent 6,165,494, U.S. Patent 6,117,417, U.S. Patent 5,993,785, U.S. Patent 5,695,746, U.S. Patent 5,470,561, U.S. Patent 4,919,918, U.S. Patent Appl. No. 2004/0076590, U.S. Patent Appl. No. 2003/0152530, and U.S. Patent Appl. No. 2002/0044910, each of which is herein specifically incorporated by reference into this section of the specification and all other sections of the specification .

[00197] Other additives may be present in the formulations of the present disclosure, such as flavoring, sweetening or coloring agents, or preservatives. Mint, such as from peppermint or spearmint, cinnamon, eucalyptus, citrus, cassia, anise and menthol are examples of suitable flavoring agents. Flavoring agents are for example present in the oral compositions in an amount in the range of from 0 to 3%; up to 2%, such as up to 0.5%, *e.g.*, around 0.2%, in the case of liquid compositions.

[00198] Sweeteners include artificial or natural sweetening agents, such as sodium saccharin, sucrose, glucose, saccharin, dextrose, levulose, lactose, mannitol, sorbitol, fructose, maltose, xylitol, thaumatin, aspartame, D-tryptophan, dihydrochalcones, acesulfame, and any combination thereof, which may be present in an amount in the range of from 0 to 2%, for example, up to 1% w/w, such as 0.05 to 0.3% w/w of the oral composition.

[00199] Coloring agents are suitable natural or synthetic colors, such as titanium dioxide or CI 42090, or mixtures thereof. Coloring agents are preferably present in the compositions in an amount in the range of from 0 to 3%; for example, up to 0.1%, such as up to 0.05%, *e.g.*, around 0.005- 0.0005%, in the case of liquid compositions. Of the usual preservatives, sodium benzoate is preferred in concentrations insufficient substantially to alter the pH of the composition, otherwise the amount of buffering agent may need to be adjusted to arrive at the desired pH.

5 [00200] Other optional ingredients include humectants, surfactants (non-ionic, cationic or amphoteric), thickeners, gums and binding agents. A humectant adds body to the formulation and retains moisture in a dentifrice composition. In addition, a humectant helps to prevent microbial deterioration during storage of the formulation. It also assists in maintaining phase stability and provides a way to formulate a transparent or translucent dentifrice.

10 [00201] Suitable humectants include glycerine, xylitol, glycerol and glycols such as propylene glycol, which may be present, for example, in an amount of up to 50% w/w each, but total humectant is in some cases not more than about 60-80% w/w of the composition. For example, liquid compositions may comprise up to about 30% glycerine plus up to about 5%, for example, about 2% w/w xylitol. Surfactants are preferably not anionic and may include polysorbate 20 or cocoamidobetaine or the like in an amount up to about 6%, for example, about 1.5 to 3%, w/w of the composition.

15 [00202] When the oral compositions of the invention are in a liquid form, it is preferred to include a film-forming agent up to about 3% w/w of the oral composition, such as in the range of from 0 to 0.1%, for example, about 0.001 to 0.01%, such as about 0.005% w/w of the oral composition. Suitable film-formers include (in addition to sodium hyaluronate) those sold under the tradename Gantrez.

20 [00203] Liquid nutritional formulations for oral or enteral administration may comprise one or more nutrients such as fats, carbohydrates, proteins, vitamins, and minerals. Many different sources and types of carbohydrates, lipids, proteins, minerals and vitamins are known and can be used in the nutritional liquid embodiments of the present invention, provided that such nutrients are compatible with the added ingredients in the selected formulation, are safe and effective for their intended use, and do not otherwise unduly impair product performance.

25 [00204] These nutritional liquids are for example formulated with sufficient viscosity, flow, or other physical or chemical characteristics to provide a more effective and soothing coating of the mucosa while drinking or administering the nutritional liquid. These nutritional embodiments also in some cases represent a balanced nutritional source suitable for meeting the sole, primary, or supplemental nutrition needs of the individual.

30 [00205] Non-limiting examples of suitable nutritional liquids are described in U. S. Patent 5,700,782 (Hwang *et al.*); U. S. Patent 5,869,118 (Morris *et al.*); and U. S. Patent 5,223,285 (DeMichele *et al.*), which descriptions are incorporated herein by reference in their entireties.

[00206] Nutritional proteins suitable for use herein can be hydrolyzed, partially hydrolyzed or non-hydrolyzed, and can be derived from any known or otherwise suitable source such as milk (*e.g.*, casein, whey), animal (*e.g.*, meat, fish), cereal (*e.g.*, rice, corn), vegetable (*e.g.*, soy), or any combination thereof.

5 [00207] Fats or lipids suitable for use in the nutritional liquids include, but are not limited to, coconut oil, soy oil, corn oil, olive oil, safflower oil, high oleic safflower oil, MCT oil (medium chain triglycerides), sunflower oil, high oleic sunflower oil, structured triglycerides, palm and palm kernel oils, palm olein, canola oil, marine oils, cottonseed oils, and any combination thereof. Carbohydrates suitable for use in the nutritional liquids may be simple
10 or complex, lactose- containing or lactose-free, or any combination thereof. Non-limiting examples of suitable carbohydrates include hydrolyzed corn starch, maltodextrin, glucose polymers, sucrose, corn syrup, corn syrup solids, rice-derived carbohydrate, glucose, fructose, lactose, high fructose corn syrup and indigestible oligosaccharides such as fructo-oligosaccharides (FOS), and any combination thereof.

15 [00208] The nutritional liquids may further comprise any of a variety of vitamins, non-limiting examples of which include vitamin A, vitamin D, vitamin E, vitamin K, thiamine, riboflavin, pyridoxine, vitamin B12, niacin, folic acid, pantothenic acid, biotin, vitamin C, choline, inositol, salts and derivatives thereof, and any combination thereof.

[00209] The nutritional liquids may further comprise any of a variety of minerals known
20 or otherwise suitable for us in patients at risk of or suffering from T1D, non- limiting examples of which include calcium, phosphorus, magnesium iron, selenium, manganese, copper, iodine, sodium, potassium, chloride, and any combination thereof.

[00210] The microorganisms and in particular the yeast and bacteria of the present invention can also be formulated as elixirs or solutions for convenient oral or rectal
25 administration or as solutions appropriate for parenteral administration, for instance by intramuscular, subcutaneous or intravenous routes. Additionally, the nucleoside derivatives are also well suited for formulation as a sustained or prolonged release dosage forms, including dosage forms that release active ingredient only or in some cases in a particular part of the intestinal tract, for example over an extended or prolonged period of time to further
30 enhance effectiveness. The coatings, envelopes, and protective matrices in such dosage forms may be made, for example, from polymeric substances or waxes well known in the pharmaceutical arts.

[00211] The compositions of the present invention include pharmaceutical dosage forms such as lozenges, troches or pastilles. These are typically discoid-shaped solids containing the active ingredient in a suitably flavored base. The base may be a hard sugar candy, glycerinated gelatin, or the combination of sugar with sufficient mucilage to give it form.

5 Troches are placed in the mouth where they slowly dissolve, liberating the active ingredient for direct contact with the mucosa.

[00212] The troche embodiments of the present invention can be prepared, for example, by adding water slowly to a mixture of the powdered active, powdered sugar, and a gum until a pliable mass is formed. A 7% acacia powder can be used to provide sufficient adhesiveness to
10 the mass. The mass is rolled out and the troche pieces cut from the flattened mass, or the mass can be rolled into a cylinder and divided. Each cut or divided piece is shaped and allowed to dry, to thus form the troche dosage form.

[00213] If the active ingredient is heat labile, it may be made into a lozenge preparation by compression. For example, the granulation step in the preparation is performed in a manner
15 similar to that used for any compressed tablet. The lozenge is made using heavy compression equipment to give a tablet that is harder than usual as it is desirable for the dosage form to dissolve or disintegrate slowly in the mouth. Ingredients are in some cases selected to promote slow-dissolving characteristics.

[00214] In a particular formulation of the present invention, the microorganisms will be
20 incorporated in a bioadhesive carrier containing pregelatinized starch and cross-linked poly (acrylic acid) to form a bioadhesive tablet and a bioadhesive gel suitable for buccal application (*i.e.*, having prolonged bioadhesion and sustained drug delivery).

[00215] In an alternative embodiment, a powder mixture of non-pathogenic and non-invasive bacterium according to the invention, bioadhesive polymers (pregelatinized starch
25 and cross-linked poly (acrylic acid) coprocessed via spray drying), sodium stearyl fumarate (lubricant), and silicium dioxide (glidant) is processed into tablets (weight: 100 mg; diameter: 7 mm). The methods for the production of these tablets are well known to the person skilled in the art and has been described before for the successful development of bioadhesive tablets containing various drugs (miconazol, testosterone, fluoride, ciprofloxacin) (Bruschi M. L.
30 and de Freitas O., *Drug Development and Industrial Pharmacy*, 2005 31:293-310). All excipient materials are commercially available in pharmaceutical grades.

[00216] To optimize a formulation, the drug load in the tablets and the ratio between starch and poly (acrylic acid) will be varied. Based on previous research, the maximum drug load in the coprocessed bioadhesive carrier is about 60% (w/w) and the starch/poly (acrylic acid) ratio can be varied between 75/25 and 95/5 (w/w). During the optimization study, the bioadhesive properties of the tablets and the drug release from the tablets are the main evaluation parameters, with the standard tablet properties (hardness, friability) as secondary evaluation criteria.

[00217] The bacteria are incorporated into an aqueous dispersion of pregelatinized starch and cross-linked poly (acrylic acid). This polymer dispersion is prepared via a standard procedure using a high shear mixer.

[00218] Similar to the tablet, the drug load of the gel and the starch/poly (acrylic acid) ratio need to be optimized in order to obtain a gel having optimal adherence to the esophageal mucosa. For a gel, the concentration of the polymers in the dispersion is an additional variable as it determines the viscosity of the gel, hence its muco-adhesive properties.

[00219] The model to screen the bioadhesive properties of polymer dispersions to the mucosa of esophagus has been described in detail by Batchelor *et al.* (*Int. J. Pharm.*, 238:123- 132, 2002).

[00220] Other routes and forms of administration include food preparations containing the live microorganisms. In some examples, the bioactive polypeptide-expressing microorganism can be included into a dairy product.

[00221] The pharmaceutical compositions of the present invention can be prepared by any known or otherwise effective method for formulating or manufacturing the selected dosage form. For example, the microorganisms can be formulated along with common, *e.g.*, pharmaceutically acceptable carriers, such as excipients and diluents, formed into oral tablets, capsules, sprays, lozenges, treated substrates (*e.g.*, oral or topical swabs, pads, or disposable, non-digestible substrate treated with the compositions of the present invention); oral liquids (*e.g.*, suspensions, solutions, emulsions), powders, suppositories, or any other suitable dosage form. In some embodiments, the present disclosure provides a method for the manufacture of a pharmaceutical composition. Exemplary methods include: contacting the microorganism (*e.g.*, the non-pathogenic bacterium) containing the IL-10 gene and the T1D-specific antigen gene (or which is capable of expressing the IL-10 and the T1D-specific antigen) with a pharmaceutically acceptable carrier, thereby forming the pharmaceutical composition. In

some examples, the method further includes: growing the microorganism in a medium. The method may further include freeze-drying a liquid containing the microorganism, wherein the liquid optionally includes the pharmaceutically acceptable carrier.

Unit Dosage Forms

5 [00222] The current disclosure further provides unit dosage forms comprising a certain amount of a non-pathogenic microorganism optionally in combination with a food-grade or pharmaceutically acceptable carrier, wherein said non-pathogenic microorganism (*e.g.*, the non-pathogenic gram-positive bacterium) comprises: an exogenous nucleic acid encoding an IL-10 polypeptide; and an exogenous nucleic acid encoding a type-1 diabetes mellitus (T1D)-
10 specific antigen (*e.g.*, PINS). Exemplary unit dosage forms contain from about 1×10^3 to about 1×10^{14} colony-forming units (cfu) of the non-pathogenic microorganism (*e.g.*, a non-pathogenic gram-positive bacterium). Other exemplary unit dosage forms contain from about 1×10^4 to about 1×10^{13} colony-forming units (cfu) of a non-pathogenic microorganism (*e.g.*, a non-pathogenic gram-positive bacterium), or from about 1×10^4 to about 1×10^{12}
15 colony-forming units (cfu) of a non-pathogenic microorganism (*e.g.*, a non-pathogenic gram-positive bacterium). In other embodiments, the unit dosage form comprises from about 1×10^5 to about 1×10^{12} colony-forming units (cfu), or from about 1×10^6 to about 1×10^{12} colony-forming units (cfu) of the non-pathogenic microorganism (*e.g.*, the non-pathogenic gram-positive bacterium). In other embodiments, the unit dosage form comprises from about
20 1×10^8 to about 1×10^{12} colony-forming units (cfu), or from about 1×10^9 to about 1×10^{12} colony-forming units (cfu) of the non-pathogenic microorganism (*e.g.*, the non-pathogenic gram-positive bacterium). In yet other embodiments, the unit dosage form comprises from about 1×10^9 to about 1×10^{11} colony-forming units (cfu), or from about 1×10^9 to about 1×10^{10} colony-forming units (cfu) of the non-pathogenic microorganism (*e.g.*, the non-pathogenic gram-positive bacterium). In yet other embodiments, the unit dosage form comprises from about
25 1×10^7 to about 1×10^{11} colony-forming units (cfu), or from about 1×10^8 to about 1×10^{10} colony-forming units (cfu) of the non-pathogenic microorganism (*e.g.*, the non-pathogenic gram-positive bacterium).

[00223] In yet other embodiments, the unit dosage form comprises from about 1×10^9 to about 1×10^{10} colony-forming units (cfu), or from about 1×10^9 to about 100×10^9 colony-forming units (cfu) of the non-pathogenic microorganism (*e.g.*, the non-pathogenic gram-positive bacterium).
30

[00224] The unit dosage form can have any physical form or shape. In some embodiments, the unit dosage form is adapted for oral administration. In some examples according to these embodiments, the unit dosage form is in the form of a capsule, a tablet, or a granule. Exemplary capsules include capsules filled with micro-granules. In some embodiments, the non-pathogenic microorganism (*e.g.*, the non-pathogenic gram-positive bacterium) contained in the dosage form is in a dry-powder form. For example, the microorganism is in a freeze-dried powder form, which is optionally compacted and coated.

[00225] This compositions and methods can be better understood by reference to the Examples that follow, but those skilled in the art will appreciate that these are only illustrative of the invention as described more fully in the numbered embodiments and claims that follow. Additionally, throughout this application, various publications are cited. The disclosures of these publications are hereby incorporated by reference in their entirety.

EXAMPLES

Example 1

15 Construction of a Clinical-Grade *Lactococcus lactis* Secreting hPINS and hIL10

[00226] A *Lactococcus lactis* strain (sAGX0407) secreting human PINS and human IL10 was generated by replacement of the chromosomally-located thymidylate synthase (*thyA*) gene in an MG1363 parental strain by an expression cassette for human PINS and IL10 using methods previously described. *See, e.g.*, Steidler L. *et al.*, *Nat. Biotechnol.* 2003; 21:785-789; and Steidler L, Rottiers P; *Annals of the New York Academy of Sciences* 2006; 1072:176-186. Methods to introduce changes into the *L. lactis* chromosome make use of double homologous recombination. A conditionally replicative carrier plasmid derived from pORI19 and containing an erythromycin selection marker, was constructed in the repA+ *L. lactis* strain LL108. Carrier plasmids were designed in such way that the cargo of interest was cloned in between up to 1 kb cross over (XO) areas, identical to the ones flanking the wild type sequence on the bacterial chromosome. This plasmid was introduced into MG1363 or any of its derivatives (repA-). Resistant colonies were selected on agar plates containing erythromycin and a first homologous recombination either at the 5' or 3' target sites was verified by PCR screening. Release of erythromycin selection enabled the excision of the carrier plasmid from the bacterial chromosome by a second homologous recombination, at either the 5' or 3' target site. The final genetic structure of the clinical-grade strain was extensively documented by both Sanger and Illumina full genome sequencing. There are no

plasmids or residual erythromycin resistance in the final clinical strain. *See, e.g.,* Steidler, L., *et al., Nat. Biotechnol.* 2003, 21(7): 785-789.

[00227] sAGX0407 is a derivative of *Lactococcus lactis* (*L. lactis*) MG1363. In sAGX0407:

- 5 • Thymidylate synthase gene (*thyA*; Gene ID: 4798358) is absent, to warrant environmental containment (Steidler, L., *et al., Nat. Biotechnol.* 2003, 21(7): 785-789).
- At the position where *thyA* had been deleted, and downstream of the constitutive promoter of the HU-like DNA-binding protein gene (*PhlIA*; Gene ID: 4797353), a gene encoding the secretion leader of unidentified secreted 45-kDa protein gene (*usp45*; Gene ID: 4797218; SSusp45) fused to the *hil-10* gene, encoding human interleukin-10 (hIL-10; UniProt: P22301, aa 19-178, variant P2A; Steidler, L., *et al., Nat. Biotechnol.* 2003, 10 21(7): 785-789) is inserted to allow expression and secretion of hIL-10.
- Trehalose-6-phosphate phosphorylase gene (*trePP*; Gene ID: 4797140) is absent, to allow accumulation of exogenously added trehalose.
- Trehalose-6-phosphate phosphatase gene (*otsB*; Gene ID: 1036914) is positioned 15 downstream of *usp45* (Gene ID: 4797218) to facilitate conversion of trehalose-6-phosphate to trehalose. The *otsB* expression unit was transcriptionally and translationally coupled to *usp45* by use of the intergenic region (IR) preceding the highly expressed *L. lactis* MG1363 50S ribosomal protein L30 gene (*rpmD*; Gene ID: 4797873).
- The constitutive promoter of the HU-like DNA-binding protein gene (*PhlIA*; Gene ID: 20 4797353) is preceding the putative phosphotransferase genes in the trehalose operon (*trePTS*; limg_0453 and limg_0454; Gene ID: 4797778 and Gene ID: 4797093 respectively) to potentiate trehalose uptake.
- The gene encoding cellobiose-specific PTS system IIC component (Gene ID: 4796893), *ptcC*, was disrupted (tga at codon position 30 of 446; tga30). This mutation ascertains 25 trehalose retention after accumulation.
- A gene encoding a fusion of *usp45* secretion leader (SSusp45) with the *pins* gene, encoding human proinsulin (PINS; UniProt: P01308, amino acids 25-110) is positioned downstream of the glyceraldehyde 3-phosphate dehydrogenase gene (*gapB*; Gene ID: 4797877), to allow expression and secretion of PINS. The *pins* expression unit was 30 transcriptionally and translationally coupled to *gapB* by use of IR*rpmD*.

[00228] All genetic traits of sAGX0407 reside on the bacterial chromosome. The genetic background of sAGX0407 provides:

- Constitutive secretion of PINS and hIL-10.
- Strict dependence on exogenously added thymidine for growth and survival.
- The capacity to accumulate and retain trehalose and so acquire the capacity to resist bile acid toxicity.

5 **[00229]** **Figure 18** shows a schematic overview of relevant genetic loci of sAGX0407 as described: trePTS, Δ trePP; otsB; ptcC-; gapB>>pins and Δ thyA, hIL-10 with indication of the relevant oligonucleotide binding sites (oAGXno), EcoRI restriction site, (/truncated/) genetic characters, intergenic regions (IR), PCR amplification product sizes (bp).

trePTS, Δ trePP

10 **[00230]** Deletion of trehalose-6-phosphate phosphorylase gene (trePP; Gene ID: 4797140); Insertion of the constitutive promoter of the HU-like DNA-binding protein gene (PhlA; Gene ID: 4797353) to precede the putative phosphotransferase genes in the trehalose operon (trePTS; llmg_0453 and llmg_0454; ptsI and ptsII; Gene ID: 4797778 and Gene ID: 4797093 respectively), insertion of the intergenic region preceding the highly expressed *L. lactis* MG1363
15 50S ribosomal protein L30 gene (rpmD; Gene ID: 4797873) in-between ptsI and ptsII (**Figures 13A, 13B, and 13C**).

otsB

[00231] Insertion of trehalose-6-phosphate phosphatase gene (*otsB*; Gene ID: 1036914) downstream of unidentified secreted 45-kDa protein gene (*usp45*; Gene ID: 4797218).
20 Insertion of the intergenic region preceding the highly expressed *L. lactis* MG1363 50S ribosomal protein L30 gene (*rpmD*; Gene ID: 4797873) between *usp45* and *otsB*. (**Figures 14A and 14B**).

ptcC -

[00232] Insertion of tga at codon position 30 of 446 (tga30), alongside with the introduction
25 of an EcoRI restriction site, to disrupt the gene encoding cellobiose-specific PTS system IIC component (*ptcC*; Gene ID: 4796893). (**Figure 15A and 15B**)

gapB>>pins

[00233] Insertion of a gene encoding a fusion of *usp45* secretion leader (*SSusp45*) with the
30 *pins* gene, encoding human proinsulin (PINS; UniProt: P01308, amino acids 25-110), downstream of the highly expressed glyceraldehyde 3-phosphate dehydrogenase gene (*gapB*; Gene ID: 4797877). Insertion of the intergenic region preceding the highly expressed *L. lactis*

MG1363 50S ribosomal protein L30 gene (*rpmD*; Gene ID: 4797873) between *gapB* and *pins* (Figures 12A, 12B, and 16)

ΔthyA, hIL-10

[00234] Deletion of thymidylate synthase gene (*thyA*; Gene ID: 4798358). Downstream of the constitutive promoter of the HU-like DNA-binding protein gene (*PhlA*; Gene ID: 4797353), insertion of a gene encoding a fusion of SSusp45 with the *hil-10* gene, encoding human interleukin-10 (hIL-10; UniProt: P22301, aa 19-178, variant P2A, Steidler *et al.*, *Nat. Biotechnol.* 2003, 21(7): 785-789) is inserted to allow expression and secretion of hIL-10 (Figure 17).

10

Example 2

Treatment of Diabetes in Mice

[00235] NOD mice were screened for the onset of diabetes by evaluating glucose levels in urine (Diastix® Reagent strips, Bayer, Leverkusen, Germany) and venous blood (AccuCheck®, Roche Diagnostics, Vilvoorde, Belgium). Mice were diagnosed as diabetic when having glucosuria and two consecutive blood glucose measurements exceeding 200 mg/dl. Upon diabetes determination, NOD or NOD transgenic mice were treated for 5 consecutive days intravenously (i.v.) (day 0-4; 2.5 μg/mouse) with hamster anti-mouse CD3 antibodies (clone 145-2C11, BioXCell, West Lebanon, NH). This therapy was given in combination with oral administration of either plasmid-driven or clinical-grade *L. lactis* strains (2×10^9 cfu) 5 times per week during 6 weeks. Control mice were left untreated. Individual blood glucose concentrations at the start of treatment were recorded. Mice were tested 3 times weekly for their weight and blood glucose status. Remission was defined as the absence of glucosuria and a return to normal blood glucose concentrations. Experimental animals were sacrificed immediately or long after stopping therapy (6 or 14 weeks after treatment initiation). Peripheral blood, lymph organs and pancreas were harvested, and single cells were assessed for phenotyping as described in the Supplemental Research Design and Methods. Mice were removed from the study prior to the 14-week endpoint when blood glucose concentrations exceeded 600 mg/dl in two consecutive measurements.

20

25

Glucose Tolerance Test

[00236] One or two weeks prior to sacrifice intraperitoneal glucose tolerance tests (IPGTT) were performed. Mice were fasted for 16 hours, injected intraperitoneally (i.p.) with

30

glucose (2 g/kg) and blood glucose concentrations were measured at 0, 15, 30, 60, 90 and 120 minutes.

IAA Measurement

[00237] Heparinized plasma was collected from new-onset diabetic NOD mice before
5 treatment randomization and at therapy discontinuation, and IAAs were analyzed at the UF
Department of Pathology, Immunology and Laboratory Medicine, College of Medicine,
Gainesville, Florida, as described in Robert S. *et al.*, *Diabetes* 2014, 63: 2876-2887.

In vivo Blocking of CTLA4 and TGF- β

[00238] Mice tolerized by *L. lactis*-based therapy were injected intraperitoneally (i.p.)
10 after therapy withdrawal with blocking antibodies against CTLA4 (clone UC10-4F10,
Bioceros) and TGF- β (clone 1D11.16.8, BioXCell) in the following dose regimen: 250 μ g at
day 1 and 3 and then 100 μ g at day 6, 8, 10, 13 and 18 for CTLA4; 200 μ g 3 times per week
during 3 weeks for TGF- β . Blood glucose concentrations were measured daily up to 25 days
after first injection.

Adoptive Transfer of Diabetes.

[00239] To assess the diabetogenic potential of Teff cells, total T cells from spleen ($1 \times$
 10^7 cells) of new-onset diabetic controls, responders and non-responders of *L. lactis*-based
therapy were transferred i.v. (intravenously) into the tail veins of 6- to 8-week-old immune-
deficient NOD-scid mice. Recipient mice were monitored twice weekly for the development
20 of diabetes up to 100 days post-cell transfer.

DT-mediated depletion of Foxp3⁺ T cells in NOD.Foxp3.DTR mice

[00240] NOD.Foxp3.DTR mice (expressing the human diphtheria toxin receptor (DTR)
under the control of Foxp3 transcriptional control elements) allow for the depletion of Foxp3⁺
T cells upon DT (diphtheria toxin) administration. *See, e.g.*, Feuerer M. *et al.*, How punctual
25 ablation of regulatory T cells unleashes an autoimmune lesion within the pancreatic islets.
Immunity 2009; 31:654-664. For Treg depletion, NOD.Foxp3.DTR mice (unmanipulated or
tolerized after stopping the *L. lactis*-based therapy) were injected i.p. with 40 μ g/kg
bodyweight of DT (Sigma) on days 1, 2, 4, and 7 and examined on day 8. Following DT
injections, weight, urine and blood glucose status of mice were monitored. Foxp3⁺ T cells
30 were monitored in peripheral blood and pancreas by flow cytometry and histology

respectively as described. *See, e.g., Tian L. et al., Foxp3(+) regulatory T cells exert asymmetric control over murine helper responses by inducing Th2 cell apoptosis. Blood* 2011; 118:1845-1853.

FOXP3-inhibitory peptide P60 in combination with L. lactis-based therapy

5 [00241] P60 (a 15-mer synthetic peptide that can bind to and block FOXP3, i.p. 50 µg/dose daily, up to 14 doses) was given either at start of the *L. lactis*-based therapy, as previously described. *See, e.g., Casares N. et al., A peptide inhibitor of FOXP3 impairs regulatory T cell activity and improves vaccine efficacy in mice. Journal of Immunology* 2010, 185:5150-5159.

10 ***Histology of pancreas and insulinitis grading***

[00242] Six-µm sections from formalin-fixed paraffin-embedded pancreas tissues were cut and collected 100-µm apart, then stained with hematoxylin eosin. Islets were observed under light microscopy at 20× or 40×, enumerated and graded by an independent investigator in blinded fashion. At least 25 islets per pancreatic sample were scored for islet infiltration as follows: 0, no infiltration; 1, peri-insulinitis; 2, islets with lymphocyte infiltration in less than 15 50% of the area, 3, islets with lymphocyte infiltration in more than 50% of the area or completely destroyed.

Islet-resident Foxp3⁺ T cell detection

[00243] Pancreas tissues were snap-frozen in 2-methyl-butane 99% and cut into 12-µm 20 tissue sections. Foxp3⁺ T cell detection was performed as described. *See, e.g., Takiishi T. et al., Reversal of autoimmune diabetes by restoration of antigen-specific tolerance using genetically modified Lactococcus lactis in mice. J. Clin. Invest.* 2012, 122:1717-1725.

Statistics

[00244] All data were analyzed using GraphPad Prism 6 (Graphpad Prism, La Jolla, CA). 25 Survival curves were computed with Kaplan-Meier test and compared with log-rank test. Groups were analyzed by ANOVA (non-parametric Kruskal-Wallis test) with Dunn's multiple comparison or with Mann-Whitney U test, as appropriate. Error bars represent SEM. Unless otherwise indicated, differences are not significant (ns). * P <0.05, ** P <0.01, *** P <0.001, **** P < 0.0001.

Bacteria and Media

[00245] *L. lactis*-pT1NX is an MG1363 strain containing the empty vector pT1NX, and served as control. The plasmid-driven *L. lactis* strain (sAGX0328 secreting plasmid-encoded human PINS and chromosomally-integrated IL10) was cultured as previously described. See, 5 *e.g.*, Takiishi T. *et al.*, J. Clin. Invest. 2012, 122:1717-17253. As growth and survival of thyA-deficient *L. lactis* strains depends on the presence of thymidine in the growth medium, the clinical-grade *L. lactis* (secreting chromosomally-integrated human PINS and IL10) was cultured in GM17T, *i.e.* M17 broth (BD, Franklin Lakes, NJ), supplemented with 0.5% glucose (Merck KGaA, Darmstadt, Germany) and 200 μ M thymidine (Sigma, St. Louis, 10 MO). For intragastric inoculations, stock suspensions were diluted 1000-fold in growth media and incubated for 16 hours at 30°C, reaching a saturation density of 2×10^9 cfu/ml. Bacteria were harvested by centrifugation and concentrated 10-fold in BM9 medium. Treatment doses consisted of 100 μ l of this bacterial suspension. For intragastric inoculations, stock suspensions were diluted 1000-fold in growth media and incubated for 16 hours at 30°C, 15 reaching a saturation density of 2×10^9 cfu/ml. Bacteria were harvested by centrifugation and concentrated 10-fold in BM9 medium. Treatment doses consisted of 100 μ l of this bacterial suspension.

Flow Cytometry

[00246] Peripheral blood and specified organs were harvested 6 weeks after treatment 20 initiation, processed and incubated with fluorochrome-labeled antibodies or matching isotype controls for flow cytometric analysis. Tregs were stained with anti-mouse CD3 (145-2C11), CD4 (GK1.5), CD8a (53-6.7), CD25 (PC61.5 or 7D4 (BD, Erembodegem, Belgium)), and FR4 (eBio12A5) (all from eBioscience, San Diego, CA, unless specified) for 20 min on ice. Intracellular staining antibodies against Foxp3 (FJK-16s) and CTLA4 (UC10-4B9) were from 25 eBioscience and used according to the manufacturer's instructions. Naïve, effector memory and central memory T cells were determined by staining with anti-mouse CD3 (145-2C11), CD4 (GK1.5), CD8a (53-6.7), CD44 (IM7), CD62L (MEL-14), CD69 (H1.2F3), and CCR7 (4B12). Cells were analyzed in a Gallios™ flow cytometer with Kaluza (Beckman Coulter, Suarlée, Belgium) or FlowJo software (Treestar, Ashland, OR).

In vitro Suppressor Assays

[00247] Pathogenic CD4⁺CD25⁻ T_H17 cells were isolated from spleen cells of 10-week old NOD mice by negative selection using antibodies to CD25, CD8 α , B220, CD11c, CD11b,

MHC class II, and sheep anti-rat IgG Dynabeads (Invitrogen, Merelbeke, Belgium). CD4⁺CD25⁺Foxp3⁺ and CD4⁺CD25⁻Foxp3⁺ Tregs were isolated from pooled lymph node and spleen cells of NOD.Foxp3.hCD2 mice (harboring a human CD2-CD52 fusion protein, along with an intra-ribosomal entry site, into the 3' untranslated region of the endogenous *foxp3* locus). See, e.g., Culina S. *et al.*, *Clin. Dev. Immunol.* 2011; 2011:286248. Briefly, cell samples were passed through a 70- μ m cell strainer and suspended in RPMI1640 medium, centrifuged for 5 min at 1,500 rpm and suspended in RPMI1640 medium. The resultant cell suspension was counted, washed and first depleted of CD8 α ⁺, B220⁺, CD11c⁺, CD11b⁺ and MHC class⁺, and adherent cells by panning and stained with biotin-conjugated anti-CD4 and anti-hCD2 antibodies. Cells were then incubated with anti-biotin microbeads (Miltenyi Biotec B.V., Leiden, The Netherlands) and separated on LS or MS columns (Miltenyi Biotec). The resulting hCD2⁺ or hCD2⁻ cells were further purified with anti-CD25 antibodies. *In vitro* polyclonal suppressor assays were conducted. Cytokines (IFN- γ , IL10 and TGF- β) were measured in cell-free supernatants by multiplex immunoassay (Mesoscale Discovery, Rockville, MA) or flow cytometric bead array (Bender MedSystems FlowCytomix™, eBioscience) as described. See, e.g., Ludvigsson J. *et al.*, GAD65 antigen therapy in recently diagnosed type 1 diabetes mellitus. *N. Engl. J. Med.* 2012, 366:433-442.

[00248] Blocking antibodies against CTLA4 (UC10-4F10), IL10 (clone JES5-2A5, BioXCell), and TGF- β (clone 1D11.16.8, which neutralizes all three mammalian TGF- β isoforms (β 1, β 2, and β 3), BioXCell) were added to cultures at a concentration of 10 μ g/ml.

Results

A clinical-grade self-contained L. lactis vaccine combined with low-dose anti-CD3 stably reversed new-onset diabetes, preserved residual beta-cell function and halted insulinitis progression in NOD mice.

[00249] Using a clinical-grade self-containing *L. lactis* strain secreting human PINS along with IL10 in combination with sub-therapeutic doses of anti-CD3 antibodies, 66% (23 out of 35) of mice reverted to normoglycemia for at least 14 weeks after disease onset, which was statistically significantly superior to 43% of mice treated by anti-CD3 alone (**Figure 1A**). Animals left untreated (n=20) or treated with the empty vector bacterial strain *L. lactis*-pT1NX (n=9) remained hyperglycemic and were sacrificed when 20% of their starting body weight was lost. Monotherapy with the clinical-grade or plasmid-driven *L. lactis* strain

secreting PINS and IL-10 was significantly less effective than the combination with anti-CD3 (0% (n=8) and 17% (n=8) respectively) (**Figure 1A**).

[00250] During follow up, new-onset diabetic controls, mice protected by *L. lactis*-based therapy, and mice not protected by such therapy, were subjected to IPGTT and sacrificed 6 weeks after treatment initiation at which time their pancreas tissues were assessed by histology. Only in the successfully treated animals, residual beta-cell function (*i.e.* assessed as area under glucose tolerance curve (AUC_{glucose})) was preserved and smaller proportions of islets had severe insulinitis (**Figure 1B**). Of interest, at the end of the combination therapy no difference in the severity of insulinitis was observed between responders and non-responders (**Figure 1C**).

Starting glycemia and IAA positivity predict therapeutic success of L. lactis-based therapy.

[00251] No influence of age or gender of mice was observed on therapeutic success of the *L. lactis*-based therapy. However, glycemic concentrations at the beginning of therapy predicted success with 82% of mice starting with a glycemia below 350 mg/dl cured (n=22), in comparison to 38% of mice with a starting glycemia above 350 mg/dl (n=13) (**Figure 2A**). In addition, positivity for IAAs at entry seemed to correlate with therapeutic success (**Figure 2B**). Interestingly, mice with blood glucose concentrations <350 mg/dl and IAA positivity at therapy start had a clearly superior diabetes remission rate (89%, n = 8) than mice with blood glucose levels >350 mg/dl and being IAA negative (33%; n = 5; P=0.07). (**Figure 2C**). Moreover, the *L. lactis*-based therapy significantly decreased IAA levels, particularly in mice responsive to the therapy (**Figure 2D**).

L. lactis-based therapy induces higher levels of Foxp3⁺ T cells with regulatory capacity but no changes in Teff cells.

[00252] The mechanisms underlying disease remission induced by the *L. lactis*-based treatment were investigated by dissociating between the therapeutic immune effects in mice responsive or not to the intervention. We found that the percentages of CD4⁺Foxp3⁺ (both CD25⁺ and CD25⁻) T cells observed in the peripheral blood (**Figure 3A**), the pancreatic draining lymph nodes (**Figure 3B**), and the pancreas (**Figure 3C**) were significantly higher in mice treated with the *L. lactis*-based therapy in comparison to untreated controls. Interestingly, in the pancreatic draining lymph nodes and pancreas, but not in peripheral blood, the increased frequency of CD4⁺Foxp3⁺ T cells was less pronounced in responders

than non-responders. Using multicolor flow cytometry, we identified that most CD4⁺Foxp3⁺ Tregs were positive for CTLA4 and that the expression of this inhibitory marker was significantly higher in pancreatic draining lymph nodes (for both responders and non-responders) and pancreas (only for responders) of treated mice compared to untreated controls (Figures 8B and 8C). Of interest, no differences in the percentages of CD4⁺Foxp3⁺CTLA4⁺ T cells were observed in the peripheral blood of treated mice compared to untreated controls (Figure 3D). The percentages of naïve (CD44⁺CD62L⁺CCR7⁺), effector memory (CD44⁺CD62L⁻CCR7⁻) and central memory (CD44⁺CD62L⁺CCR7⁺) CD4⁺ T cells were not altered in any recipient group with respect to therapeutic success or failure. Transfer of splenocytes from responders and non-responders of *L. lactis*-based treatment caused diabetes in NOD-scid recipients with similar disease kinetics as transfer of splenocytes isolated from untreated new-onset diabetic controls, suggesting that circulating diabetogenic cells were not depleted from treated mice (Figure 9).

Diabetes reversal induced by L. lactis-based therapy is accompanied by and depends on the generation of functional Foxp3⁺ Tregs.

[00253] Using NOD.Foxp3.hCD2 mice treated by *L. lactis*-based therapy, we could isolate CD4⁺CD25⁺Foxp3⁺ T cells for functional *in vitro* studies, in which they suppressed proliferation, CD69 activation and IFN- γ production of pathogenic CD4⁺CD25⁻ Teff cells. These Tregs produced IL-10 (and TGF- β) when they were co-cultured and stimulated with anti-CD3 antibody in the presence of splenic antigen-presenting cells (APCs) isolated from NOD-scid γ c^{-/-} mice (Figure 4). No difference in regulatory capacity of CD4⁺CD25⁺Foxp3⁺ T cells was seen between therapy responders and non-responders.

[00254] Addition of anti-CTLA4 Ig (clone UC10-4F10) or a TGF- β neutralizing antibody (clone 1D11.16.8) significantly reduced the suppression by the CD4⁺CD25⁺Foxp3⁺ T cells (Figure 5A), suggesting that CD4⁺CD25⁺Foxp3⁺ Tregs of cured mice inhibit Teff proliferation via a CTLA4- and TGF- β -dependent fashion *in vitro*. Adding anti-IL10 (clone JES5-2A5) did not alter the direct suppressive effect of the Tregs. On the other hand, these regulatory mechanisms were not demonstrated with the CD4⁺CD25⁺Foxp3⁺ T cell fraction from therapy responders and non-responders (Figure 5B). Treating stably cured mice *in vivo* with a combination of anti-CTLA4 Ig (clone UC10-4F10) and anti-TGF- β (clone 1D11.16.8) led to diabetes recurrence in 2 out of 5 mice (Figure 5C).

[00255] Finally, we investigated whether the therapeutic success of *L. lactis*-based therapy was depended on the presence and functionality of Foxp3⁺ T cells. For this, new-onset diabetic NOD mice were simultaneously treated with the *L. lactis*-based therapy and the FOXP3-inhibitory peptide P60 for a period of 14 days (**Figure 6A**). Interestingly, none of the mice (n=6) developed normoglycemia, while mice treated with the *L. lactis*-based therapy and vehicle (n=11) had a 60% diabetes remission rate, indicating that Tregs are crucial for induction of therapy-induced tolerance (**Figure 6B**).

[00256] New-onset (spontaneously) diabetic NOD.Foxp3.DTR mice were treated with the *L. lactis*-based therapy and after stable diabetes reversal was observed, Foxp3⁺ T cells were eliminated using DT as described in the scheme depicted in **Figure 7A**. First, we established in unmanipulated NOD.Foxp3.DTR mice that the selected DT regimen eliminated over 90% of CD4⁺Foxp3⁺ T cells, with the remaining Tregs expressing low or no CD25, in the peripheral blood within 3 days after first DT injection (**Figures 10A-C**). A progressive repopulation of these cells started from day 5 after first DT injection as has been reported for several Foxp3.DTR strains. See, e.g., Kim J.M. *et al.*, *Nat. Immunol.* 2007, 8:191-197; Suffner J. *et al.*, *J. Immunol.* 2010, 184:1810-1820; and Mayer C.T. *et al.*, *Immun. Inflamm. Dis.* 2014, 2:162-165. This DT regimen also dramatically decreased the amount of Foxp3⁺ T cells residing in the pancreas, consequently leading to the development of autoimmune diabetes (**Figures 10B and 10D**). Next, comparable to wild-type NOD mice, the *L. lactis*-based treatment induced autoimmune diabetes remission in 57% of NOD.Foxp3.DTR mice (4 out of 7 mice) (**Figures 7A and 7B**). Transient Foxp3⁺ T cell depletion resulted in a complete reversal to the diabetic state in all mice (n=4) that were initially cured by the therapy, as evidenced by the reappearance of glucosuria along with severe hyperglycemia starting from day 2 after first DT injection (**Figure 7B**). This breach of immune tolerance to insulin-producing beta-cells was also accompanied by the induction of severe insulinitis (**Figure 7C**) and the ablation of the islet-resident Foxp3⁺ Treg pool (**Figure 7D**). Collectively, these data demonstrated that the therapeutic effect from the *L. lactis*-based intervention depended on the presence and functionality of Foxp3⁺ Tregs.

Discussion

[00257] Oral tolerance as a means of intervention to arrest disease has been explored in animal models of autoimmune disease including T1D. *See, e.g.,* Commins SP, *Pediatr. Clin. North. Am.* 2015; 62:1523-1529.

5 [00258] In this example, an oral clinical-grade self-containing *L. lactis* strain secreting chromosomally-integrated human PINS and human IL-10 was prepared. When combined with a short course of sub-therapeutic doses of anti-CD3, the intervention was safe and effective in inducing long-term normoglycemia in new-onset diabetic mice. Initial blood glucose concentrations (<350 mg/dl) in addition to IAA positivity at disease onset were
10 predictors of therapeutic outcome, while preservation of residual beta-cell function and decline in IAA positivity were markers of therapeutic success.

[00259] Thus, some degree of residual beta-cell mass will be necessary for therapeutic success when intervening at the moment of diabetes diagnosis, namely when dysglycemia is present.

15 [00260] By dissociating between the immune effects of the *L. lactis*-based intervention in mice responsive or not to the therapy, the nature and role of the immune processes accompanying the treatment was further characterized. The *L. lactis*-based therapy induced suppressive IL-10-secreting CD4⁺Foxp3⁺ (both CD25⁺ and CD25⁻) T cells in the pancreatic draining lymph nodes and pancreas of responders and even more so of non-responders,
20 suggesting enhanced recruitment of Tregs to the inflamed target tissues. In the periphery, the frequency of CD4⁺Foxp3⁺ T cells was also increased in treated mice compared to untreated controls, pointing towards a possible use this cell population as immune marker. Interestingly, the frequency of CTLA4⁺ T-cells among various Treg subsets was significantly higher in the pancreas of combination therapy-treated responder mice compared to new-onset
25 diabetic mice and in contrast to combination therapy-treated non-responder mice. No difference was seen in the degree of insulinitis between responder and non-responder mice, suggesting alterations in lymphocyte subsets other than Tregs.

[00261] Peripheral Tregs can use different regulatory mechanisms according to their environmental milieu and stimulatory conditions. *See, e.g.,* Liston A. *et al., Nature Reviews*
30 *Immunology* 2014; 14:154-165. In these experiments, CTLA4 and TGF- β were important for the regulatory activity of therapy-expanded CD4⁺CD25⁺Foxp3⁺ T cells *in vitro* and partially *in vivo*, while IL-10 was not.

[00262] Although IL-10 seemed to be a good marker for the identification of our *L. lactis*-based therapy-induced Tregs, others have demonstrated that anti-IL-10 antibodies did not abrogate established tolerance *in vivo*. See, e.g., Fowler S. and Powrie F, *European Journal of Immunology* 2002, 32:2997-3006.

5 [00263] As in mice, human Tregs are defined by having a suppressive phenotype endowed by high and sustained expression of the transcription factor Foxp3 (see, e.g., Hori S. *et al.*, *Science* 2003; 299:1057-1061) and loss of function/mutation in the Foxp3 gene leads to severe fatal autoimmune disorders (see, e.g., Kim J.M., *et al.*, *Nature Immunology* 2007; 8:191-197; and Mayer C.T. *et al.*, *European Journal of Immunology* 2014, 44:2990-3002).

10 [00264] Specific inhibition of Treg functionality by the P60 peptide (see, e.g., Casares N. *et al.*, *Journal of Immunology* 2010; 185:5150-5159) at the start of *L. lactis*-based therapy impaired the induction of therapy-induced tolerance. Moreover, transient depletion of Foxp3⁺ Tregs from therapy-tolerized NOD.Foxp3. DTR mice was sufficient to induce complete disease relapse in all animals, demonstrating that the presence of Foxp3⁺ T cells
15 was important to maintain therapeutic tolerance and control pathogenic Teff cells which were still present in mice responsive to *L. lactis*-based therapy.

[00265] The current data demonstrate that combining a clinical-grade self-containing *L. lactis* secreting human PINS and human IL-10 with low-dose anti-CD3 increased the frequency of diabetes reversal compared to anti-CD3 mono-therapy. Both therapy responders
20 and non-responders had increased frequencies of CD4⁺Foxp3⁺ T cells, suggesting that immune effects induced by the *L. lactis*-based therapy occurred in each individual recipient, but that therapeutic success (defined as return to stable normoglycemia) depended on other parameters, such as functional beta-cell mass still present at disease onset. Therapeutic success was further correlated with starting glycemia. Next to initial blood glucose
25 concentrations at entry, also IAA levels predicted outcome of this *L. lactis*-based therapy using PINS as antigen. The current data demonstrates that Foxp3⁺ Tregs were essential to induce and maintain active tolerance and control diabetogenic immune responses in tolerized mice. These findings provide tools for testing interventions in humans: a clinical-grade self-containing *L. lactis* secreting islet antigen(s), biomarkers for predicting therapeutic success,
30 and the demonstration that the induction of Foxp3⁺ T cells is the basis of the *L. lactis*-based therapy.

[00266] While some embodiments have been shown and described herein, such embodiments are provided by way of example only. Numerous variations, changes, and

substitutions will occur to those skilled in the art without departing from the invention. It should be understood that various alternatives to the embodiments of the invention described herein will be employed in practicing the invention.

Exemplary embodiments

5

1. A lactic acid bacterium (LAB) comprising an exogenous nucleic acid encoding interleukin-10 (IL-10), and an exogenous nucleic acid encoding proinsulin (PINS), wherein said exogenous nucleic acid encoding IL-10 and said exogenous nucleic acid encoding PINS are chromosomally integrated.
- 10 2. The LAB of embodiment 1, wherein said LAB is a *Lactococcus* species bacterium.
3. The LAB of embodiment 2, wherein said LAB is *Lactococcus lactis*.
4. The LAB of embodiment 3, wherein said LAB is *Lactococcus lactis* subspecies *cremoris*.
5. The LAB of embodiment 4, wherein said LAB is *Lactococcus lactis* strain MG1363.
- 15 6. The LAB of any one of embodiments 1 to 5, wherein said IL-10 is human IL-10 (hIL-10).
7. The LAB of embodiment 6, wherein said hIL-10 when secreted as a mature hIL-10 without a signal peptide comprises alanine (Ala) instead of proline (Pro) at position 2.
8. The LAB of any one of embodiments 1 to 7, wherein said IL-10 has an amino acid sequence at least 95% identical to SEQ ID NO: 1.
- 20 9. The LAB of any one of embodiments 1 to 8, wherein said exogenous nucleic acid encoding IL-10 has a nucleotide sequence at least 95% identical to SEQ ID NO: 2.
10. The LAB of any one of the preceding embodiments, wherein said PINS is human PINS (hPINS).
11. The LAB of any one of the preceding embodiments, wherein said PINS has an amino acid
25 sequence at least 95% identical to SEQ ID NO: 3.
12. The LAB of any one of the preceding embodiments, wherein said exogenous nucleic acid encoding PINS has a nucleotide sequence at least 95% identical to SEQ ID NO: 4.

13. The LAB of any one of the preceding embodiments, wherein said LAB constitutively expresses said IL-10.
14. The LAB of embodiment 13, wherein said LAB secretes said IL-10.
15. The LAB of any one of the preceding embodiments, wherein said LAB constitutively
5 expresses said PINS.
16. The LAB of embodiment 15, wherein said LAB secretes said PINS.
17. The LAB of any one of the preceding embodiments, wherein said LAB constitutively expresses and secretes said IL-10 and said PINS.
18. The LAB of any one of the preceding embodiments, wherein said exogenous nucleic acid
10 encoding IL-10 is positioned 3' of an *hllA* promoter (*PhllA*).
19. The LAB of embodiment 18, wherein said *PhllA* is a *Lactococcus lactis PhllA*.
20. The LAB of embodiment 18, wherein said exogenous nucleic acid encoding IL-10 is transcriptionally regulated by said *PhllA*.
21. The LAB of any one of the preceding embodiments, wherein said LAB comprises an
15 expression cassette comprising an *hllA* promoter, an IL-10 secretion sequence, and said exogenous nucleic acid encoding IL-10.
22. The LAB of embodiment 21, wherein said expression cassette is chromosomally integrated.
23. The LAB of embodiment 22, wherein said expression cassette is chromosomally
20 integrated at a *thyA* locus.
24. The LAB of any one of embodiments 21 to 23, wherein said IL-10 secretion sequence is a nucleotide sequence encoding a secretion leader of unidentified secreted 45-kDa protein (Usp45) (SSusp45).
25. The LAB of any one of the preceding embodiments, wherein said exogenous nucleic acid
25 encoding PINS is positioned 3' of a *gapB* promoter.

26. The LAB of embodiment 25, wherein said exogenous nucleic acid encoding PINS is transcriptionally regulated by said *gapB* promoter.
27. The LAB of embodiment 25 or 26, wherein said LAB comprises a first polycistronic expression cassette comprising a *gapB* promoter positioned 5' of a *gapB* gene, a PINS secretion sequence, and said exogenous nucleic acid encoding PINS.
28. The LAB of embodiment 27, wherein said LAB further comprises an intergenic region between said *gapB* gene and said PINS secretion sequence.
29. The LAB of embodiment 28, wherein said intergenic region is *rpmD* having SEQ ID NO: 8 or SEQ ID NO: 9.
30. The LAB of any one of embodiments 27 to 29, wherein said *gapB* promoter and said *gapB* gene are endogenous to said LAB.
31. The LAB of any one of embodiments 27 to 30, wherein said first polycistronic expression cassette is chromosomally integrated.
32. The LAB of any one of embodiments 27 to 31, wherein said PINS secretion sequence is a nucleotide sequence encoding SSusp45.
33. The LAB of embodiment 32, wherein said SSusp45 has a nucleotide sequence of SEQ ID NO: 11 or SEQ ID NO: 12.
34. The LAB of any one of the preceding embodiments, wherein said LAB further comprises an exogenous nucleic acid encoding a trehalose-6-phosphate phosphatase.
35. The LAB of embodiment 34, wherein said trehalose-6-phosphate phosphatase is *Escherichia coli* OtsB.
36. The LAB of embodiment 34 or 35, wherein said exogenous nucleic acid encoding a trehalose-6-phosphate phosphatase is chromosomally integrated.
37. The LAB of embodiment 36, wherein said exogenous nucleic acid encoding a trehalose-6-phosphate phosphatase is chromosomally integrated 3' of unidentified secreted 45-kDa protein gene (*usp45*).

38. The LAB of embodiment 37, wherein said LAB comprises a second polycistronic expression cassette comprising a *usp45* promoter, said *usp45*, and said exogenous nucleic acid encoding a trehalose-6-phosphate phosphatase.
39. The LAB of embodiment 38, wherein said second polycistronic expression cassette
5 further comprises an intergenic region between said *usp45* and said exogenous nucleic acid encoding a trehalose-6-phosphate phosphatase.
40. The LAB of embodiment 39, wherein said intergenic region is *rpmD* having SEQ ID NO: 8 or SEQ ID NO: 9.
41. The LAB of any one of the preceding embodiments, wherein a trehalose-6-phosphate
10 phosphorylase gene (*trePP*) is disrupted or inactivated in said LAB.
42. The LAB of embodiment 41, wherein said *trePP* is inactivated by removing said *trePP* or a fragment thereof.
43. The LAB of embodiment 41, wherein said *trePP* is disrupted by insertion of a stop codon.
- 15 44. The LAB of any one of embodiments 41-43, wherein said LAB lacks *trePP* activity.
45. The LAB of any one of the preceding embodiments, wherein a cellobiose-specific PTS system IIC component gene (*ptcC*) is disrupted or inactivated in said LAB.
46. The LAB of embodiment 45, wherein said *ptcC* is disrupted by inserting a stop codon.
47. The LAB of embodiment 45, wherein said *ptcC* is inactivated by removing said *ptcC* or a
20 fragment thereof.
48. The LAB of any one of embodiments 45 to 47, wherein said LAB lacks *ptcC* activity.
49. The LAB of any of the preceding embodiments, wherein said LAB further comprises one or more genes encoding one or more trehalose transporter(s).
50. The LAB of embodiment 49, wherein said one or more genes encoding one or more
25 trehalose transporter(s) is endogenous to said LAB.

51. The LAB of embodiment 49 or 50, wherein said LAB overexpresses said one or more trehalose transporter(s).
52. The LAB according to any one of embodiments 49 to 51, wherein said one or more genes encoding one or more trehalose transporter(s) is/are positioned 3' of an *hllA* promoter (*PhllA*).
53. The LAB of embodiment 52, wherein said one or more genes encoding one or more trehalose transporter(s) is/are transcriptionally regulated by said *PhllA*.
54. The LAB of any one of embodiments 47 to 51, wherein said one or more genes encoding one or more trehalose transporter(s) is/are selected from the group consisting of *llmg_0453*, *llmg_0454*, and any combination thereof.
55. The LAB of embodiment 54, wherein said one or more genes encoding one or more trehalose transporter(s) comprises two genes encoding two trehalose transporters, wherein an intergenic region is located between said two genes.
56. The LAB of embodiment 55, wherein said intergenic region is *rpmD* having SEQ ID NO: 8 or SEQ ID NO: 9.
57. A composition comprising the LAB of any one of the preceding embodiments.
58. A pharmaceutical composition comprising the LAB of any one of embodiments 1 to 56, and a pharmaceutically acceptable carrier.
59. The LAB of any one of embodiments 1 to 56, the composition of embodiment 57, or the pharmaceutical composition of embodiment 58, for use in the treatment of type-1 diabetes (T1D).
60. The LAB of any one of embodiments 1 to 56, the composition of embodiment 57, or the pharmaceutical composition of embodiment 58, for use in the preparation of a medicament for the treatment of T1D.
61. The LAB, the composition, or the pharmaceutical composition of embodiment 60, wherein said T1D is recent-onset T1D.

62. A method for the treatment of T1D in a subject in need thereof comprising administering to said subject a therapeutically effective amount of the LAB of any one of embodiments 1 to 56, the composition of embodiment 57, or the pharmaceutical composition of embodiment 58.
- 5 63. The method of embodiment 62, wherein said T1D is recent-onset T1D.
64. The method of embodiment 62 or 63, wherein said subject is a human.
65. The method of any one of embodiments 62 to 64, wherein said method further comprises administering a therapeutically effective amount of an anti-CD3 antibody to said subject.
66. The method of embodiment 65, wherein said anti-CD3 antibody is a monoclonal
10 antibody.
67. The method of embodiment 65 or 66, wherein said anti-CD3 antibody is oteplizumab or teplizumab.
68. The method of any one of embodiments 65 to 67, wherein said antibody is administered to said subject using a co-therapeutic regimen.
- 15 69. The method of any one of embodiments 65 to 68, wherein said administering said LAB and said administering said anti-CD3 antibody:
- (i) reduces an amount of insulin the subject needs to maintain a normal blood glucose level, when compared to a corresponding subject treated with anti-CD3 antibody alone, or compared to a corresponding subject not being administered said LAB and
20 said anti-CD3 antibody;
- (ii) preserves initial beta-cell function in said subject for at least about 2 months as measured by C-peptide level;
- (iii) maintains normal glycemia in the subject for at least about 2 months;
- (iv) maintains a normal hemoglobinA1c (HbA1c) level in said subject for at least about 2
25 months; or
- (v) any combination thereof.
70. The method of any one of embodiments 62 to 69, wherein the method further comprises measuring insulin autoantibody (IAA) in said subject.

71. A method for preparing a genetically modified LAB comprising (i) contacting an LAB with an exogenous nucleic acid encoding IL-10; and (ii) contacting said LAB with an exogenous nucleic acid encoding PINS, wherein said exogenous nucleic acid encoding IL-10, and said exogenous nucleic acid encoding PINS are chromosomally integrated.
- 5 72. The method of embodiment 71, wherein said exogenous nucleic acid encoding IL-10 and said exogenous nucleic acid encoding PINS are chromosomally integrated using homologous recombination.
73. The method of embodiment 71 or 72, wherein said contacting said LAB with an exogenous nucleic acid encoding IL-10 occurs prior to said contacting said LAB with an
10 exogenous nucleic acid encoding PINS.
74. The method of embodiment 71 or 72, wherein said contacting said LAB with an exogenous nucleic acid encoding IL-10 occurs subsequent to said contacting said LAB with an exogenous nucleic acid encoding PINS.
75. The method of any one of embodiments 71 to 74, further comprising combining a culture
15 of said genetically modified LAB with at least one stabilizing agent to form a bacterial mixture.
76. The method of embodiment 75, further comprising removing water from said bacterial mixture forming a dried composition.
77. The method of embodiment 76, comprising freeze-drying said bacterial mixture to form a
20 freeze-dried composition.
78. The method of embodiment 77, wherein said at least one stabilizing agent comprises at least one cryopreserving agent.
79. The method of any one of embodiments 71 to 78, further comprising combining said genetically modified LAB, said dried composition, or said freeze-dried composition with
25 a pharmaceutically acceptable carrier to form a pharmaceutical composition.
80. The method of any one of embodiments 76 to 79, further comprising formulating said dry composition, said freeze-dried composition or said pharmaceutical composition into a pharmaceutical dosage form.

81. A genetically modified bacterium prepared by the method of any one of embodiments 71 to 80.
82. A method for preparing a pharmaceutical composition comprising contacting a culture of the LAB of any one of embodiments 1 to 56 with at least one stabilizing agent forming a bacterial mixture.
83. The method of embodiment 82, further comprising removing water from said bacterial mixture, thereby forming a dried composition.
84. The method of embodiment 82 or 83, comprising freeze-drying said bacterial mixture thereby forming a freeze-dried composition.
85. The method of any one of embodiments 82 to 84, wherein said at least one stabilizing agent comprises at least one cryopreserving agent.
86. The method of embodiment 84 or 85, further comprising contacting said freeze-dried composition with a pharmaceutically acceptable carrier forming a pharmaceutical composition.
87. The method of any one of embodiments 84 to 86, further comprising formulating said freeze-dried composition into a pharmaceutical dosage form.
88. The method of embodiment 87, wherein said pharmaceutical dosage form is selected from the group consisting of a tablet, a capsule, a granule, and a sachet.
89. A unit dosage form comprising the LAB of any one of embodiments 1 to 56, the composition of embodiment 57, or the pharmaceutical composition of embodiment 58.
90. The unit dosage form of embodiment 89, wherein said unit dosage form is an oral dosage form.
91. The unit dosage form of embodiment 90, wherein said oral dosage form is selected from the group consisting of a tablet, a capsule, a granule, and a sachet.
92. The unit dosage form of any one of embodiments 89 to 91, wherein said unit dosage form comprises from about 1×10^6 to about 1×10^{12} colony forming units (cfu) of said LAB.

93. The unit dosage form of embodiment 92 comprising from about 1×10^8 to about 1×10^{11} cfu.
94. A kit comprising (1) an LAB according to any one of embodiments 1 to 56, a composition according to embodiment 57, a pharmaceutical composition of embodiment 58, or a unit dosage form of any one of embodiments 89 to 93, and (2) instructions for administering said LAB, said composition, said pharmaceutical composition, or said unit dosage form to a mammal.
95. The kit of embodiment 94, wherein said mammal is a human.
96. A bacterial suspension comprising the LAB of any one of embodiments 1 to 56, a solvent, and a stabilizing agent.
97. The bacterial suspension of embodiment 96, wherein said solvent is selected from water, oil, and any combination thereof.

CLAIMS**What is claimed is**

1. A lactic acid bacterium (LAB) comprising an exogenous nucleic acid encoding human interleukin-10 (hIL-10), and an exogenous nucleic acid encoding human proinsulin (hPINS), wherein said exogenous nucleic acid encoding hIL-10 and said exogenous nucleic acid encoding hPINS are chromosomally integrated.
2. The LAB of claim 1, wherein said LAB is *Lactococcus lactis*.
3. The LAB of claim 1, wherein said hIL-10, when secreted as a mature hIL-10 without a signal peptide, comprises alanine (Ala) instead of proline (Pro) at position 2.
4. The LAB of claim 1, wherein said hIL-10 has an amino acid sequence at least 95% identical to SEQ ID NO: 1, or wherein said exogenous nucleic acid encoding IL-10 has a nucleotide sequence at least 95% identical to SEQ ID NO: 2.
5. The LAB of claim 4, wherein the exogenous nucleic acid encoding hIL-10 further encodes a secretion sequence coupled to hIL-10, wherein said secretion sequence is unidentified secreted 45-kDa protein (Usp45) (SSusp45).
6. The LAB of claim 4, wherein said exogenous nucleic acid encoding hIL-10 is positioned 3' of an *hllA* promoter (*PhllA*), such as a *Lactococcus lactis PhllA*.
7. The LAB of claim 4, comprising an expression cassette comprising an *hllA* promoter that transcribes SSusp45 coupled to hIL-10, wherein the expression cassette is chromosomally integrated at the *thyA* locus.
8. The LAB of claim 1, wherein said hPINS has an amino acid sequence at least 95% identical to SEQ ID NO: 3, or wherein said exogenous nucleic acid encoding hPINS has a nucleotide sequence at least 95% identical to SEQ ID NO: 4.
9. The LAB of claim 8, wherein the exogenous nucleic acid encoding hPINS further encodes a secretion sequence coupled to hPINS, wherein said secretion sequence is unidentified secreted 45-kDa protein (Usp45) (SSusp45).
10. The LAB of claim 8, wherein said exogenous nucleic acid encoding hPINS comprises a first polycistronic expression cassette comprising a *gapB* promoter positioned 5' of

- a *gapB* gene, an hPINS secretion sequence, and said exogenous nucleic acid encoding hPINS.
11. The LAB of claim 10 wherein said LAB further comprises an intergenic region, such as *rpmD*, between said *gapB* gene and said PINS secretion sequence.
 12. The LAB of claims 5 or 9, wherein said SSusp45 has a nucleotide sequence of SEQ ID NO: 11 or SEQ ID NO: 12.
 13. The LAB of claim 1, wherein said LAB constitutively expresses and secretes said hIL-10 and said hPINS.
 14. The LAB of any one of the preceding claims, wherein said LAB further comprises an exogenous nucleic acid encoding a trehalose-6-phosphate phosphatase, such as *Escherichia coli* OtsB.
 15. The LAB of claim 14, wherein said exogenous nucleic acid encoding a trehalose-6-phosphate phosphatase is chromosomally integrated 3' of unidentified secreted 45-kDa protein gene (*usp45*).
 16. The LAB of claim 14, further comprising a second polycistronic expression cassette comprising a *usp45* promoter, said *usp45*, and an exogenous nucleic acid encoding a trehalose-6-phosphate phosphatase and optionally an intergenic region, such as *rpmD*, between said *usp45* and said exogenous nucleic acid encoding a trehalose-6-phosphate phosphatase.
 17. The LAB of claim 1, further comprising one or more genes encoding one or more trehalose transporter(s), such as *llmg_0453* or *llmg_0454*.
 18. The LAB of claim 17, comprising two trehalose transporter(s) positioned 3' of an *hllA* promoter (*PhllA*), transcriptionally regulated by said *PhllA*, and wherein the genes encoding the trehalose transporters are separated by an intergenic region, such as *rpmD*.
 19. The LAB of claim 1, further wherein a trehalose-6-phosphate phosphorylase gene (*trePP*) is disrupted or inactivated in said LAB.

20. The LAB of claim 1 wherein a cellobiose-specific PTS system IIC component gene (*ptcC*) is disrupted or inactivated in said LAB.
21. The LAB of claim 1, being a *Lactococcus lactis* having chromosomally inserted
 - a. an expression cassette comprising an *hllA* promoter that transcribes *SSusp45* coupled to hIL-10, wherein the expression cassette is chromosomally integrated at the *thyA* locus;
 - b. a first polycistronic expression cassette comprising a *gapB* promoter positioned 5' of a *gapB* gene, an hPINS secretion sequence, and said exogenous nucleic acid encoding hPINS;
 - c. *Escherichia coli otsB*;
 - d. a second polycistronic expression cassette comprising a *usp45* promoter, *usp45*, and an exogenous nucleic acid encoding a trehalose-6-phosphate phosphatase and optionally an intergenic region, such as *rpmD*, between said *usp45* and said exogenous nucleic acid encoding a trehalose-6-phosphate phosphatase;
 - e. a third polycistronic expression cassette comprising trehalose transporters *llmg_0453* and *llmg_0454*, positioned 3' of an *hllA* promoter (*PhllA*);
 - f. inactivation of *trePP*; and
 - g. inactivation of *ptcC*.
22. A composition comprising the LAB of any one of the preceding claims.
23. The use of the LAB of the claims 1-21, or the composition of claim 22, in the treatment of type-1 diabetes (T1D).
24. The use of the LAB of the claims 1-21, or the composition of claim 22, for the preparation of a medicament for the treatment of T1D.
25. A method for the treatment of T1D in a subject in need thereof comprising administering to said subject a therapeutically effective amount of the LAB of any one of the preceding claims, and an antibody against CD3, such as oteelixumab.

26. The method of claim 25, wherein said administering said LAB and said administering said anti-CD3 antibody:
- a. reduces an amount of insulin the subject needs to maintain a normal blood glucose level, when compared to a corresponding subject treated with anti-CD3 antibody alone, or compared to a corresponding subject not being administered said LAB and said anti-CD3 antibody;
 - b. preserves initial beta-cell function in said subject for at least about 2 months as measured by C-peptide level;
 - c. maintains normal glycemia in the subject for at least about 2 months;
 - d. maintains a normal hemoglobinA1c (HbA1c) level in said subject for at least about 2 months; or
 - e. any combination thereof.

Figure 1A

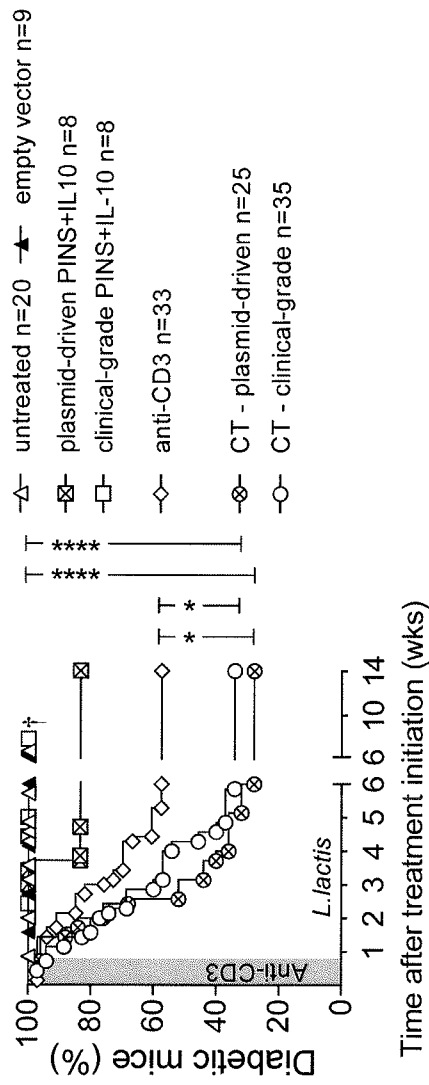

Figure 1B

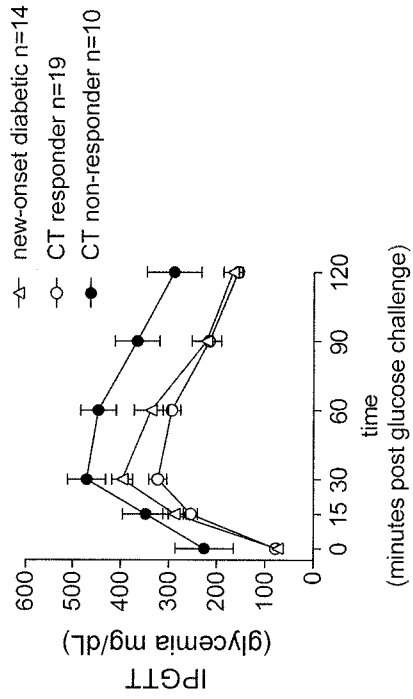
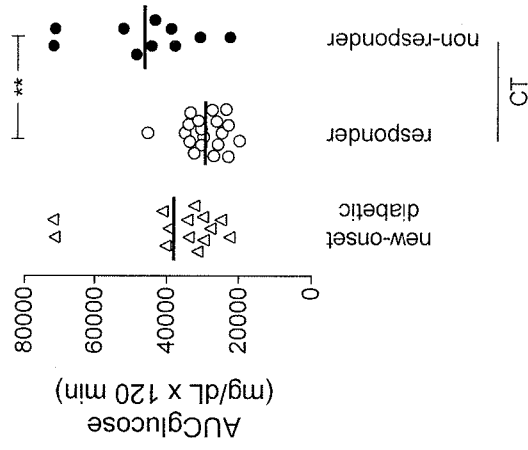

Figure 1C

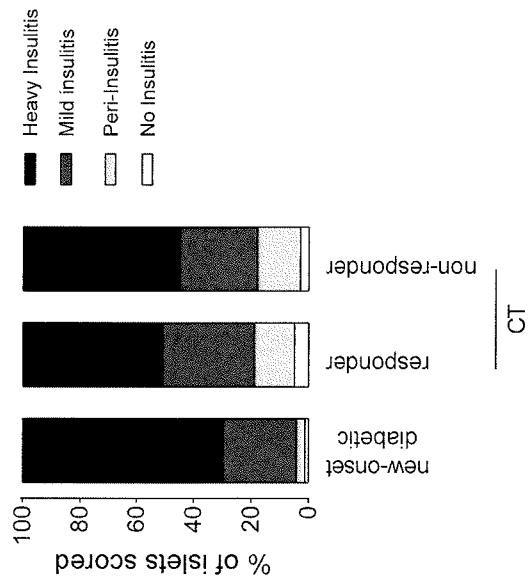

Figure 2A

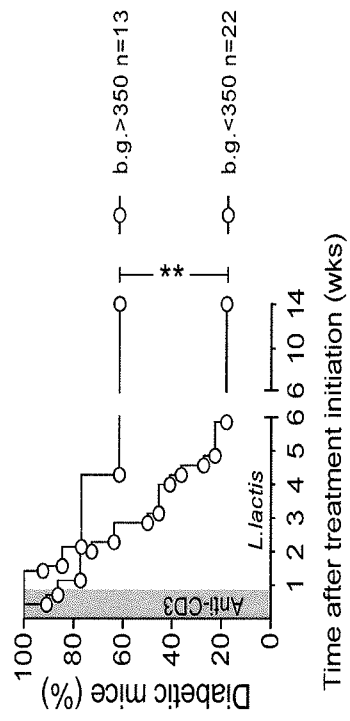

Figure 2B

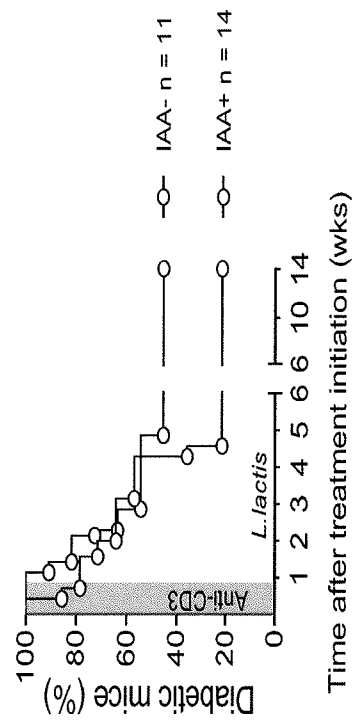

Figure 2C

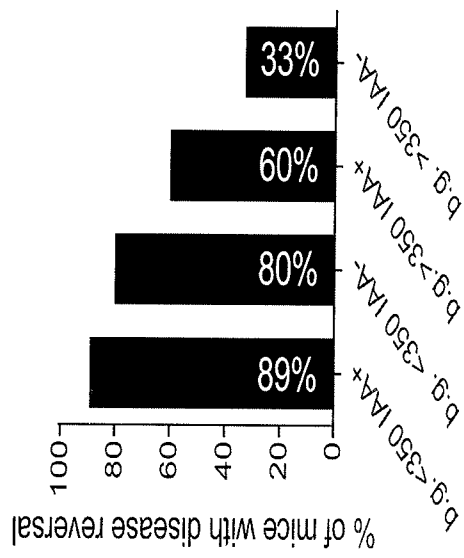
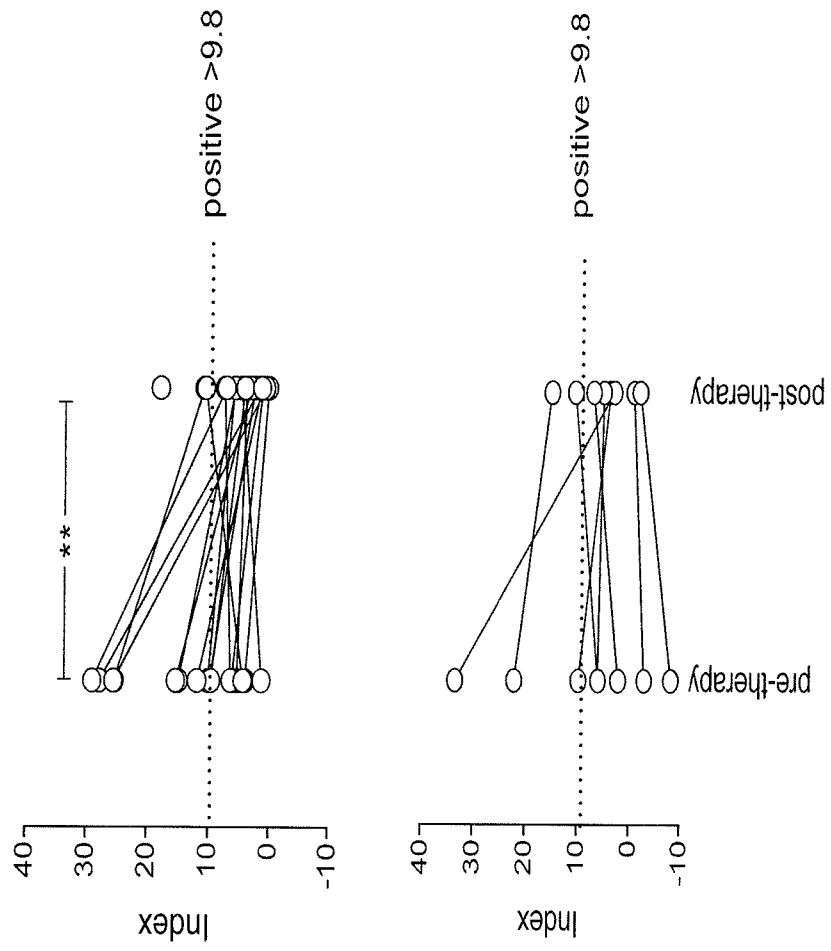

Figure 2D



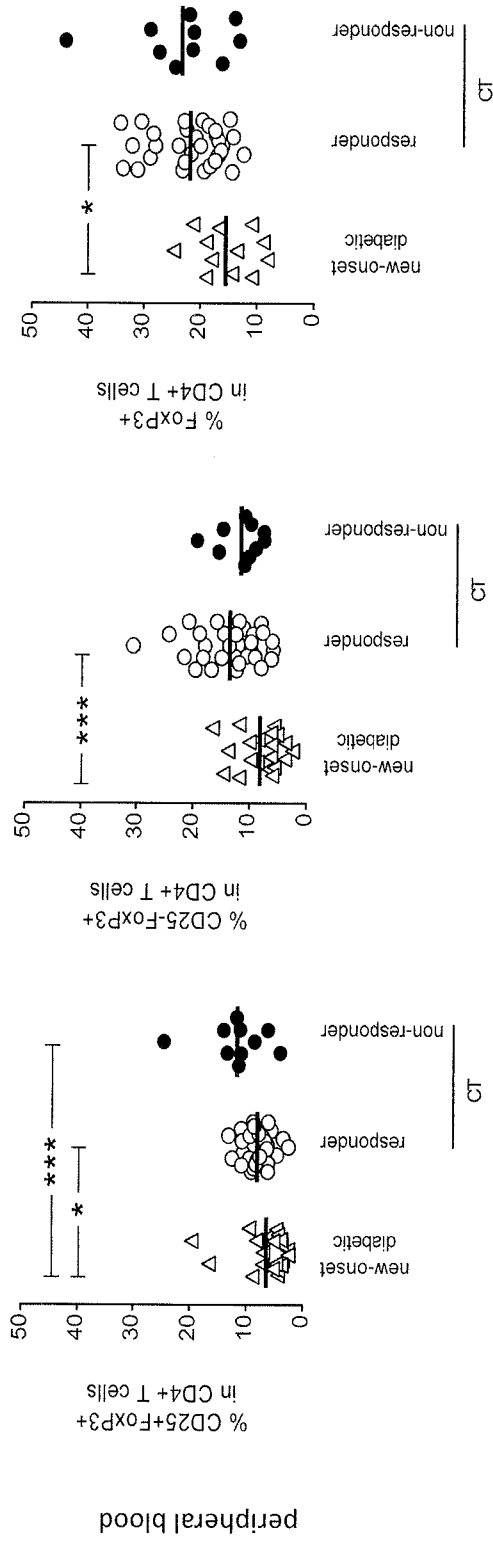
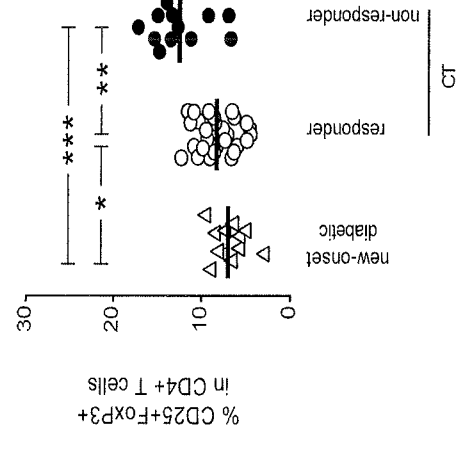
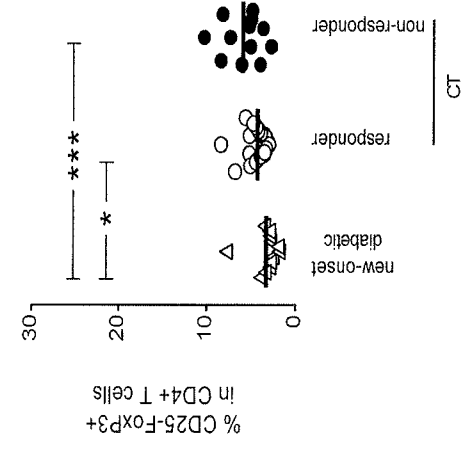
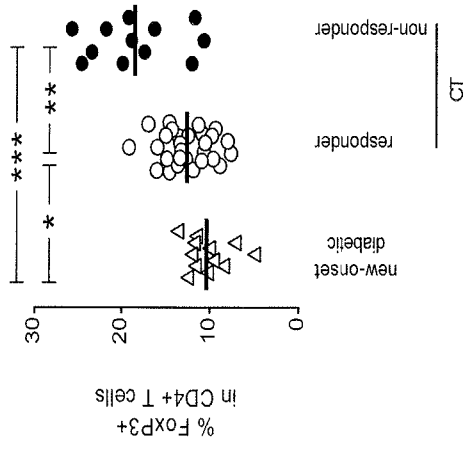

Figure 3A



pancreatic lymph nodes

Figure 3B

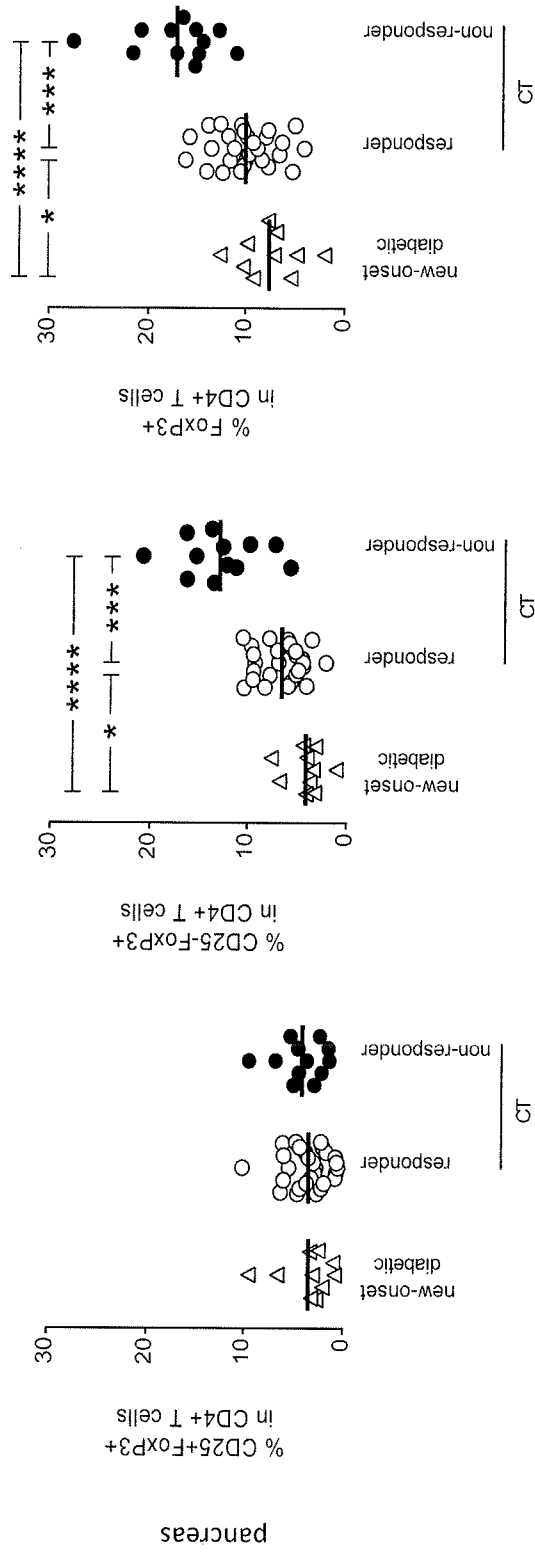

Figure 3C

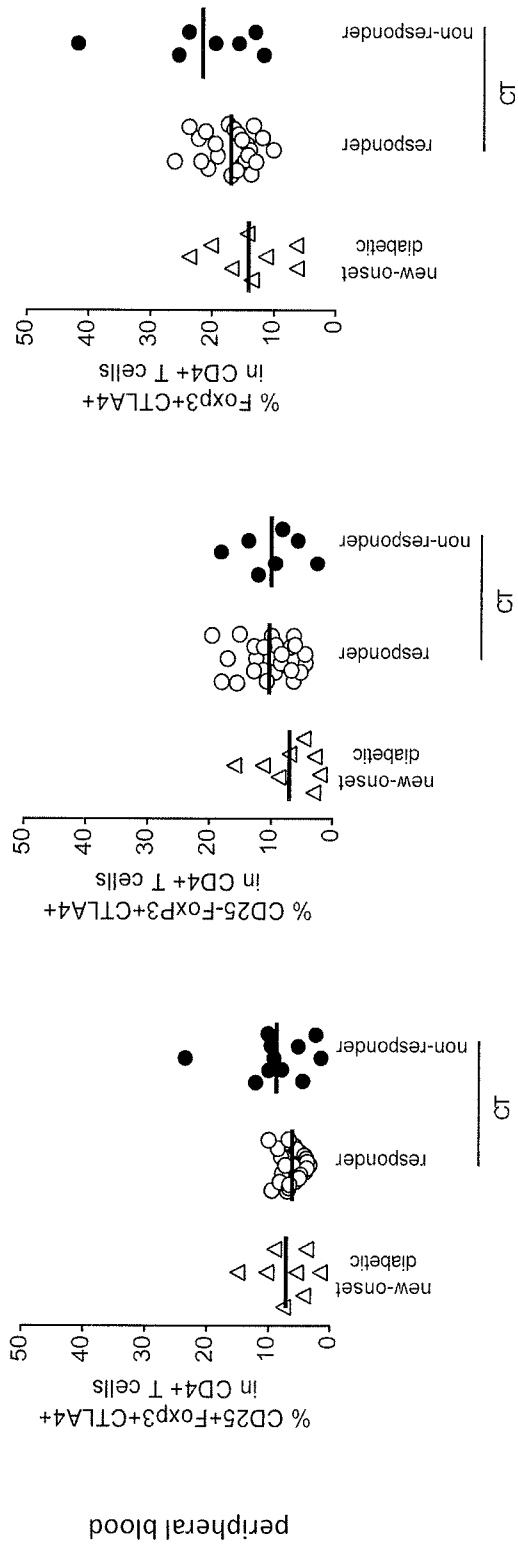

Figure 3D

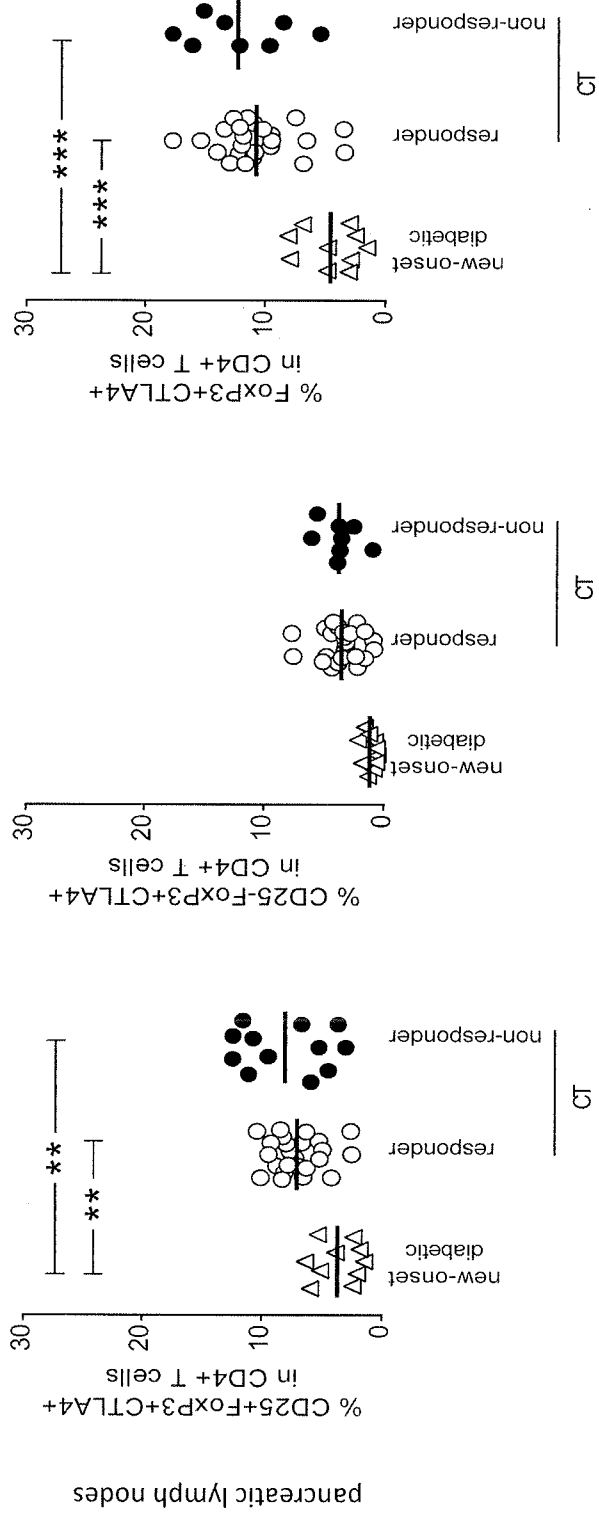

Figure 3E

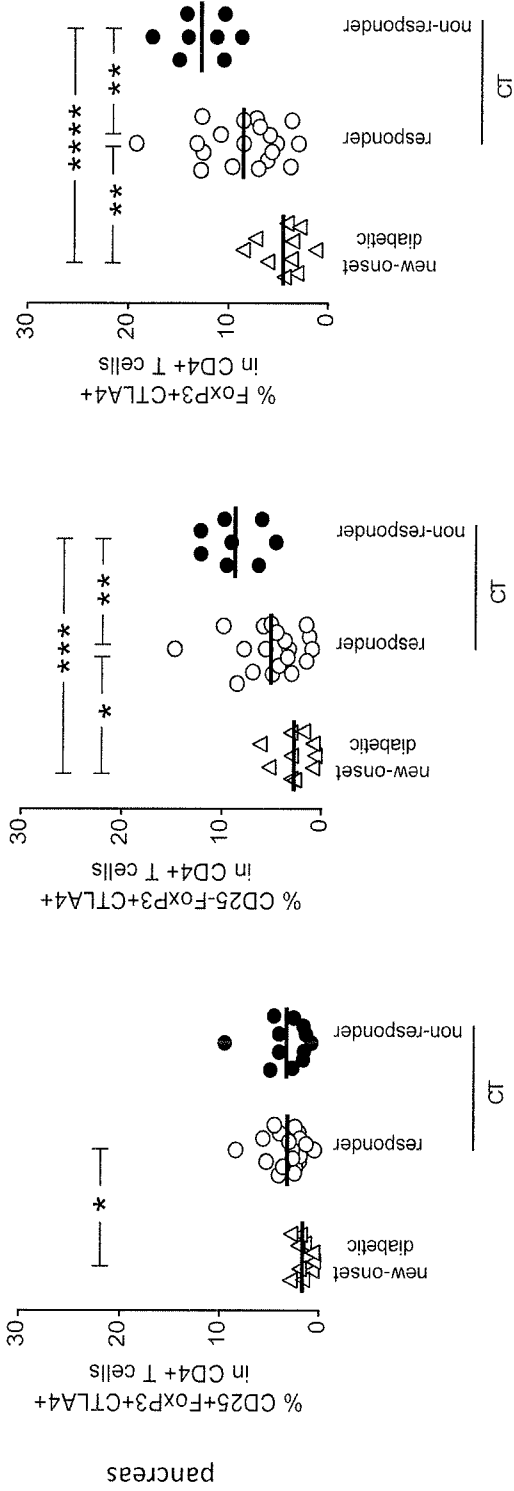

Figure 3F

Figure 4

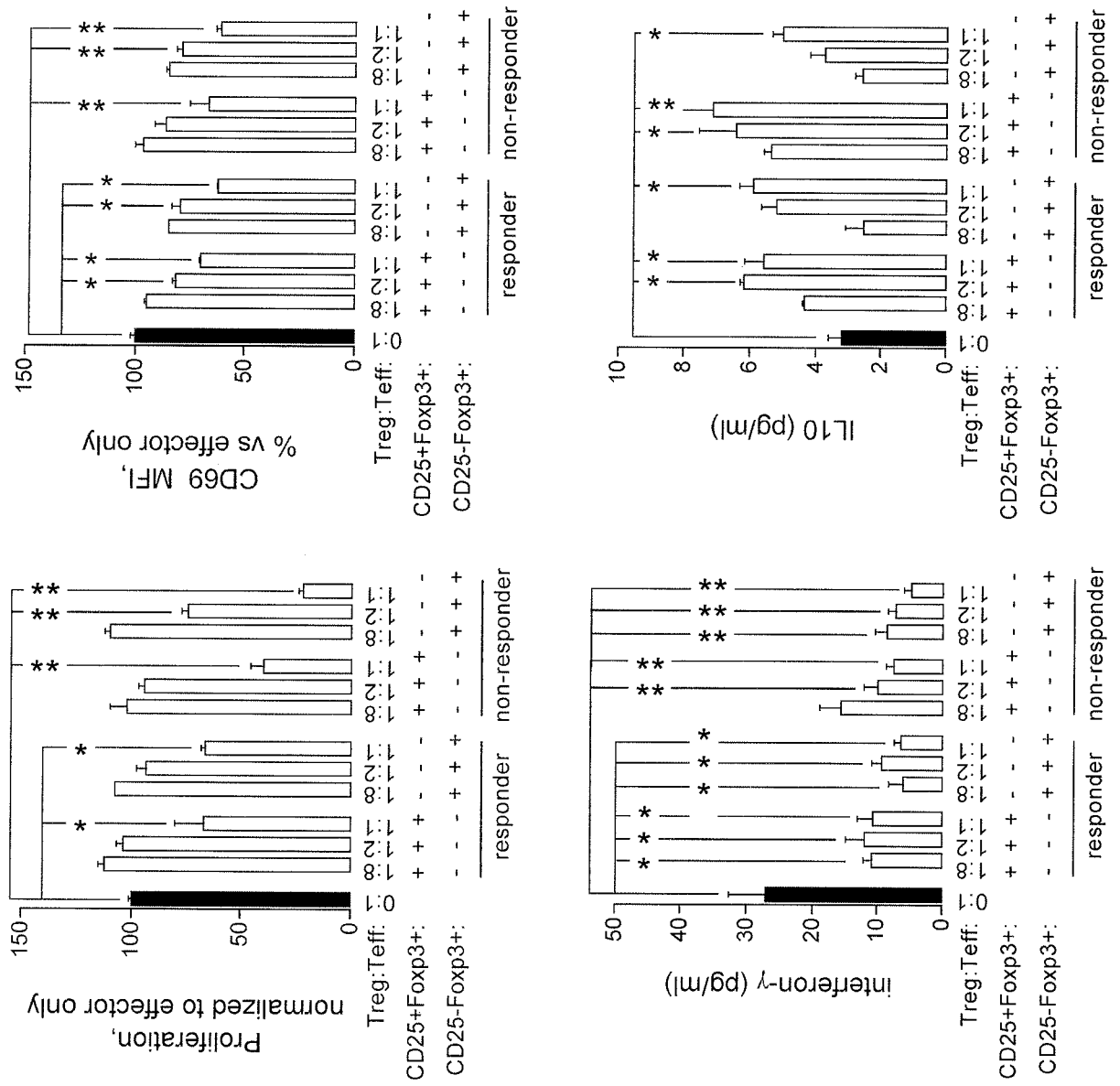

Figure 5C

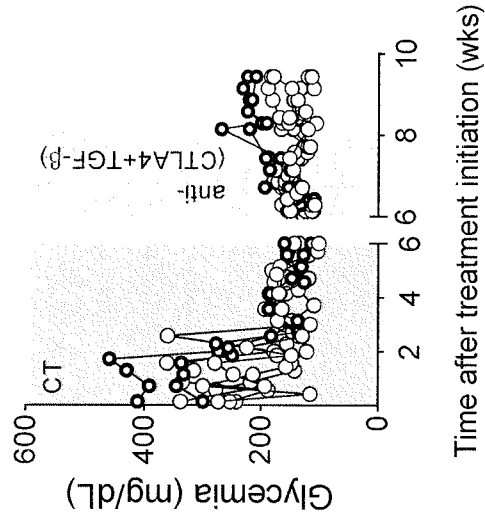

Figure 5B

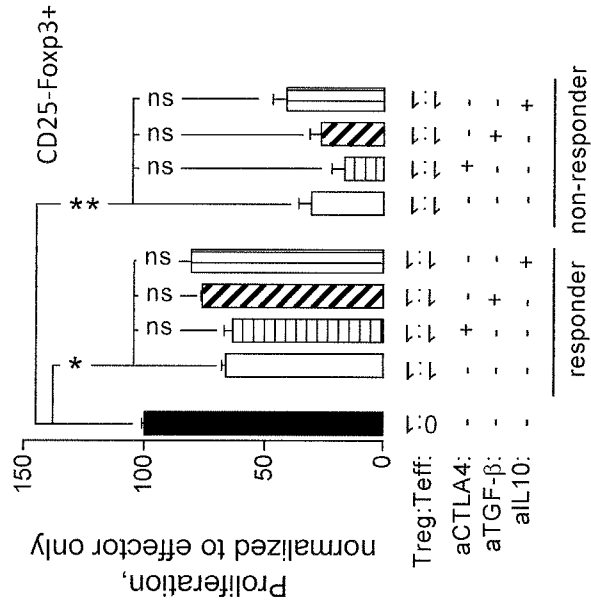

Figure 5A

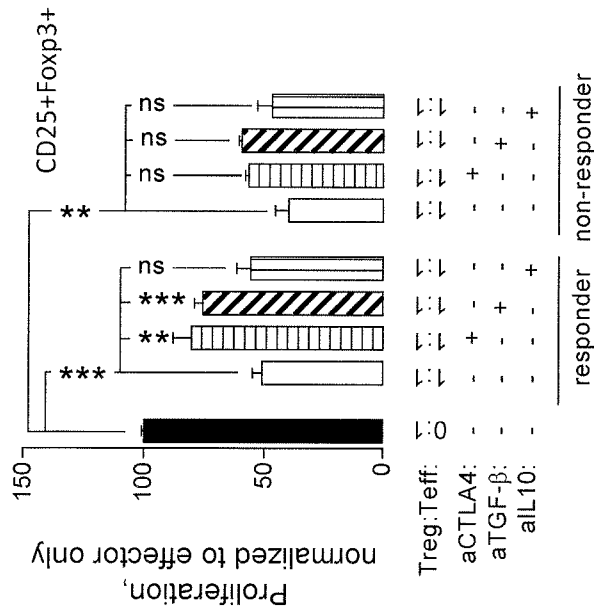

Figure 6A

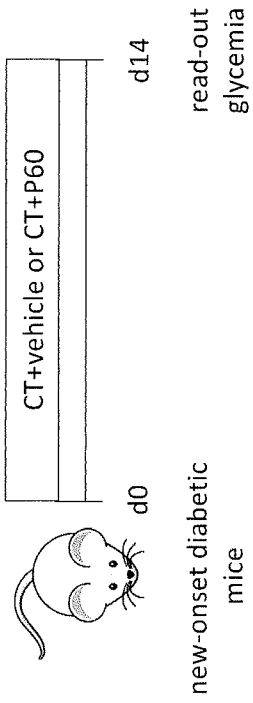

Figure 6B

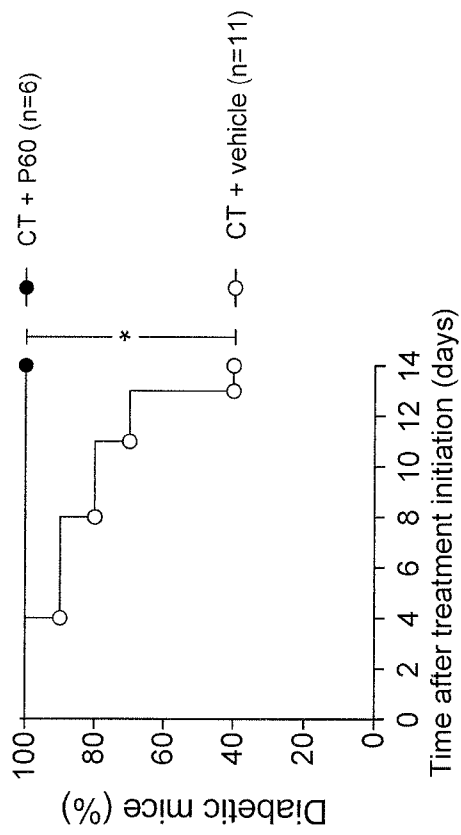
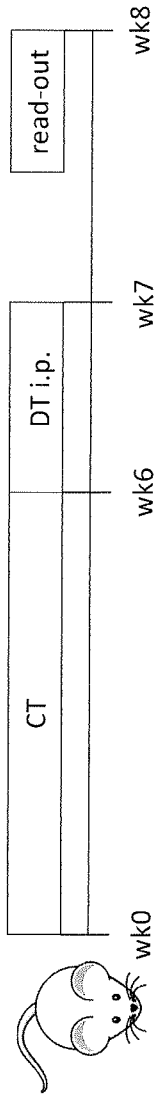

Figure 7A



new-onset diabetic CT responder
NOD.Foxp3.DTR mice NOD.Foxp3.DTR mice

Figure 7B

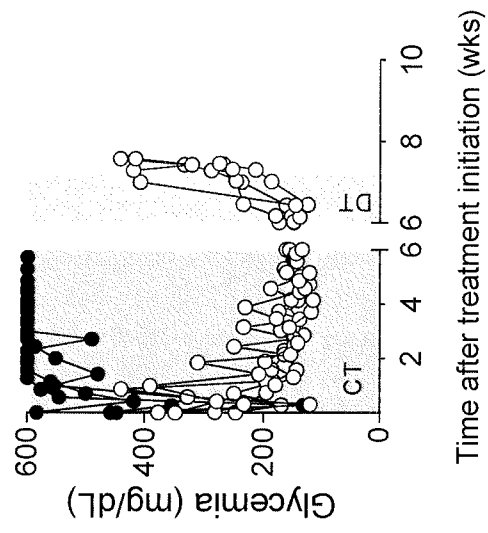

Figure 7C

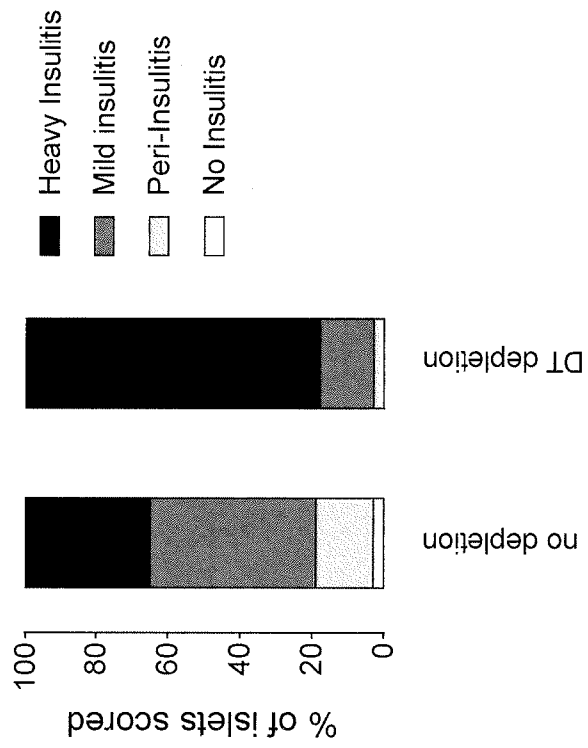

Figure 7D

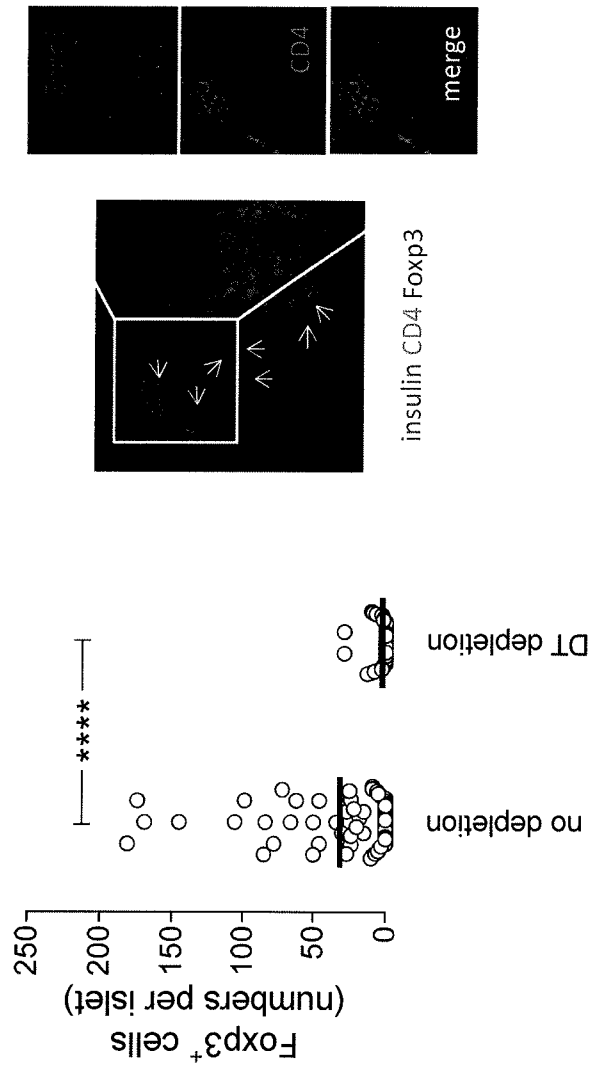
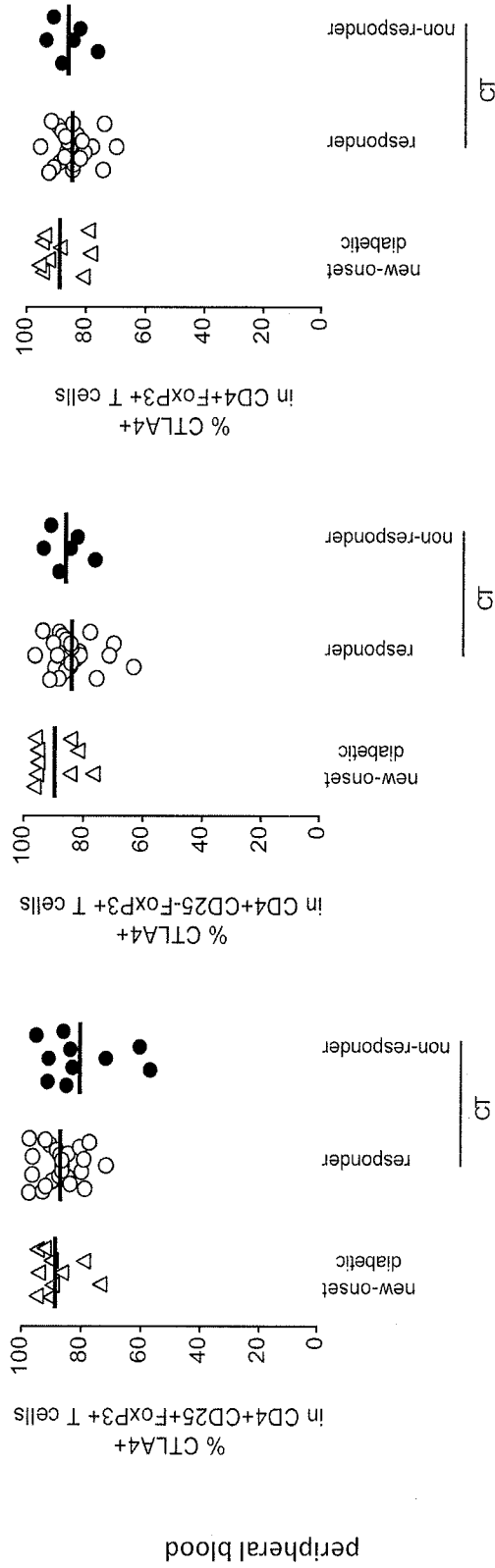

Figure 8A



pancreatic lymph nodes

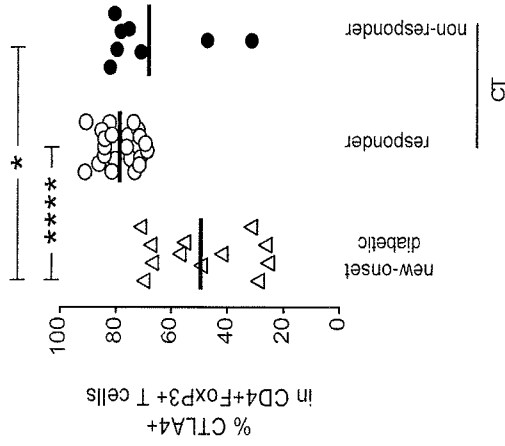
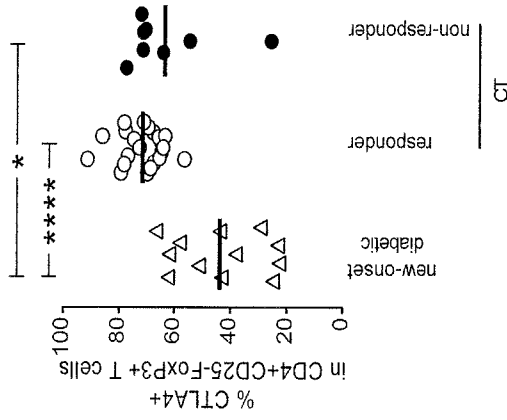
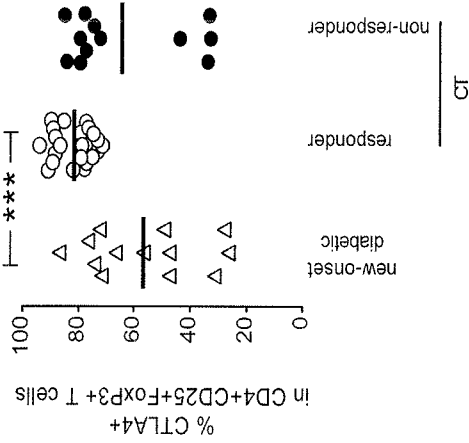

Figure 8B

Figure 8C

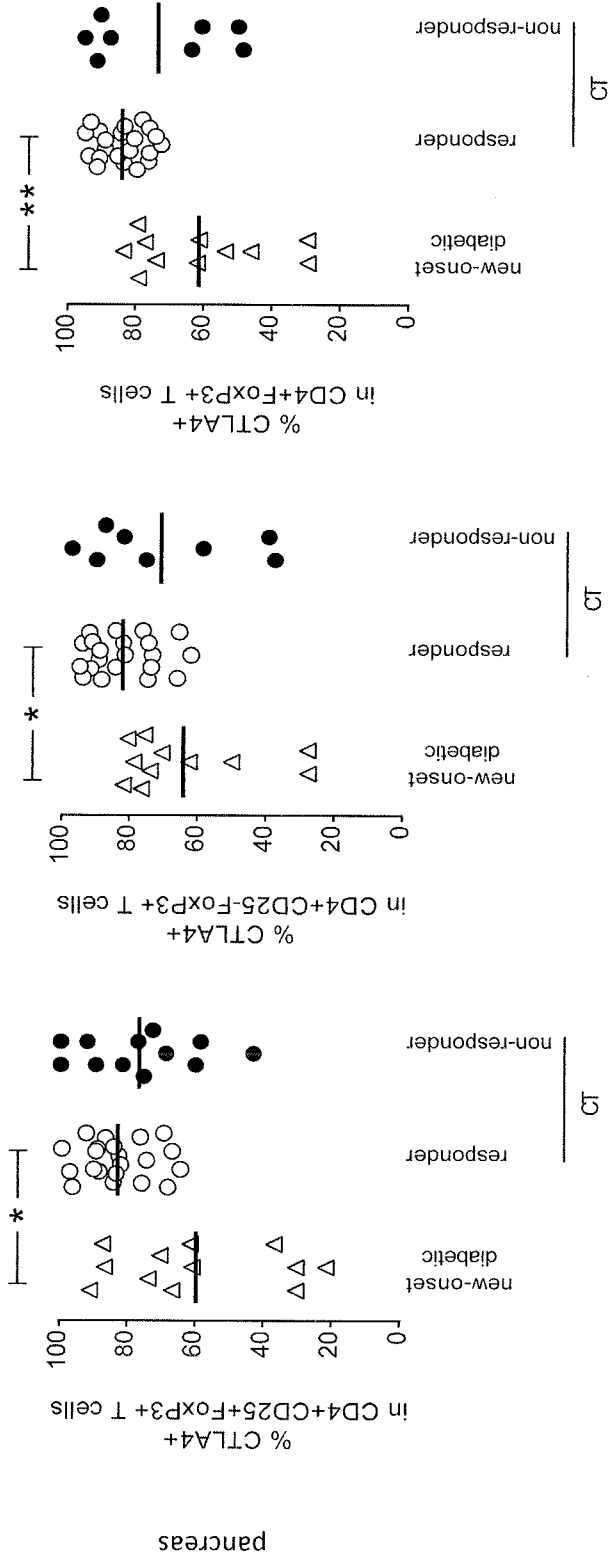

Figure 9

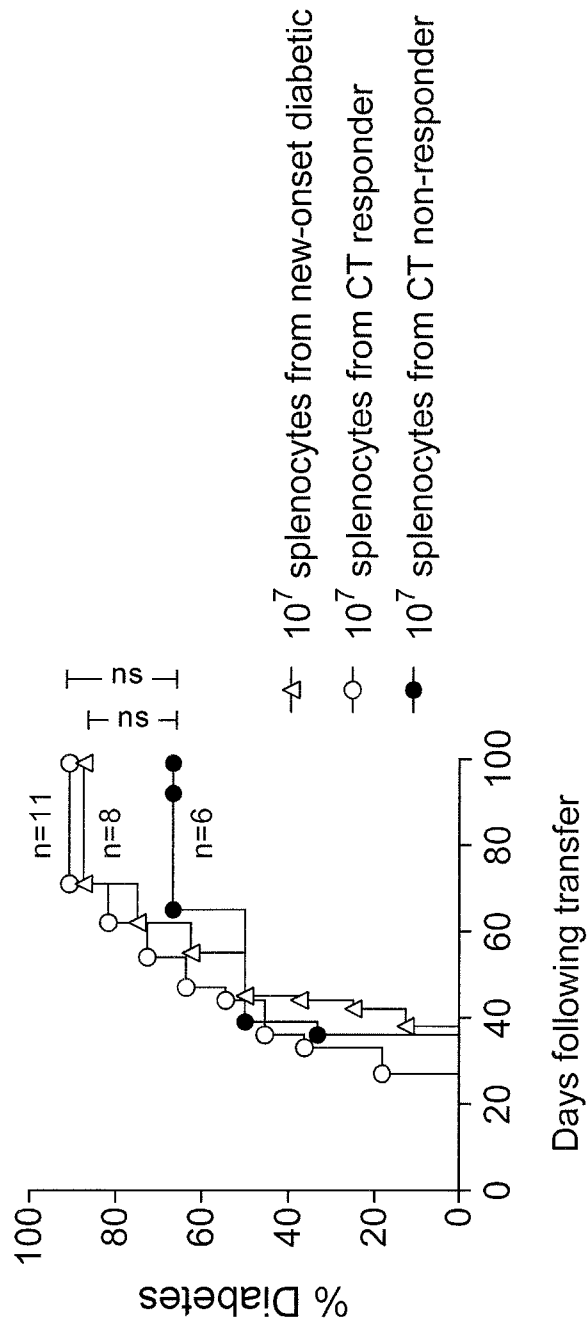
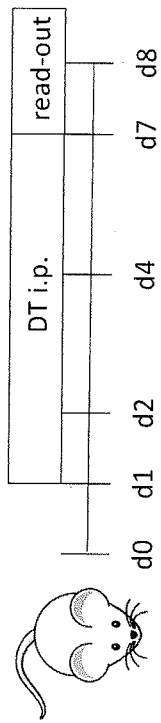

Figure 10A



NOD.Foxp3.DTR mice

Figure 10B

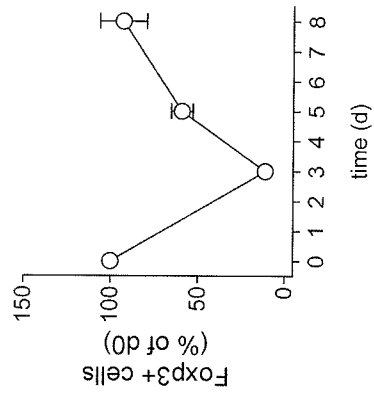
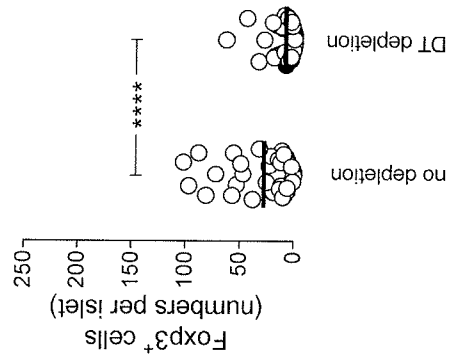

Figure 10C

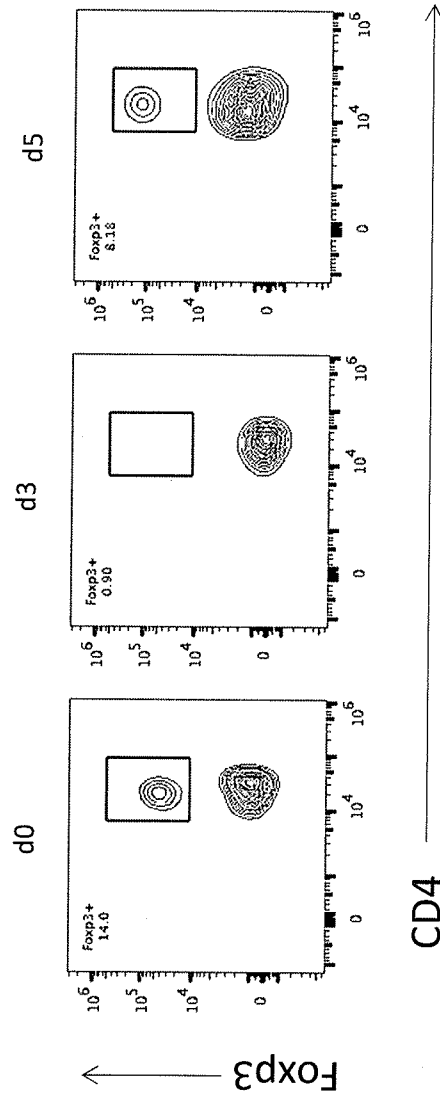

Figure 11

```

1   aaaacgcctt aaaatggcat tttgacttgc aaactgggct aagatttgct aaaatgaaaa
   >>.....Phl1A.....>

61  atgcctatgt ttaaggtaaa aaacaaatgg aggacatttc taaaatgaaa aaaagatta
   >.....Phl1A.....>>
                                     >>...SSusp45....>
                                     m k k k i

121 tctcagctat tttaatgtct acagtgatac tttctgctgc agccccgttg tcaggtgttt
   >.....SSusp45.....>
   i s a i l m s t v i l s a a a p l s g v

181 acgcctcagc tggccaaggt actcaatcag aaaactcatg tactcacttt ccaggttaact
   >..>> SSusp45
   y a
   >>.....hIL10aPxA.....>
   s a g q g t q s e n s c t h f p g n

241 tgccaaacat gcttcgtgat ttgcgtgatg ctttttcacg tgttaaaact tttttcaaa
   >.....hIL10aPxA.....>
   l p n m l r d l r d a f s r v k t f f q

301 tgaagatca acttgataac ttgcttttga aagaatcact tttggaagat ttaaagggt
   >.....hIL10aPxA.....>
   m k d q l d n l l l k e s l l e d f k g

361 accttggttg tcaagctttg tcagaaatga tccaatttta ccttgaagaa gttatgccac
   >.....hIL10aPxA.....>
   y l g c q a l s e m i q f y l e e v m p

421 aagctgaaaa ccaagatcca gatatcaaag ctcacgttaa ctcattgggt gaaaacctta
   >.....hIL10aPxA.....>
   q a e n q d p d i k a h v n s l g e n l

481 aaactttgcg tcttcgtttg cgtcgttgc accgttttct tccatgtgaa aacaaatcaa
   >.....hIL10aPxA.....>
   k t l r l r l r r c h r f l p c e n k s

541 aagctgttga acaagttaa aacgctttta acaaattgca agaaaaaggt atctacaaag
   >.....hIL10aPxA.....>
   k a v e q v k n a f n k l q e k g i y k

601 ctatgtcaga atttgatata tttatcaact acatcgaagc ttacatgact atgaaaatcc
   >.....hIL10aPxA.....>
   a m s e f d i f i n y i e a y m t m k i

661 gtaactaact agaattaatc tataagttac tgacaaaact gtcagtaact ttttttgtgg
   >.....>> hIL10aPxA
   r n -
    
```

Figure 12A

```

1  aataaaaatt actgacagcc tgctcagtaa tttttttagt cataatTTTT aggtggaag
61  tcaaagatta ttgccaaaag tatttagcttt tttaatgtta accgctttca gaagaagggg
121 agttcatttg cttttgtaga gcgctttcta aggtagttta tgtttgcaaa ttttaaaaa
                                     PgapB >>.>
                                     k
181 agtgttaaaa taaaagagta agttaaattg ttaacttagt caatttaaaa ggtttgcctt
>.....PgapB.....>
241 ttataaaatc taatccctat aaggaggaaa ctactaatgg tagttaaagt tggattaac
>.....PgapB.....>>
                                     >>.....gapB.....>
                                     m v v k v g i n
301 ggtttcggtc gtatcggtcg tcttgctttc cgtcgtattc aaaatgttga aggtgttgaa
>.....gapB.....>
   g f g r i g r l a f r r i q n v e g v e
361 gttgttgcaa tcaacgactt gacagatcca gcaatgcttg ctcacttgct taaatacgat
>.....gapB.....>
   v v a i n d l t d p a m l a h l l k y d
421 acaactcaag gtcgttttga tggtaaagtt gaagttaaag atggtggttt tgaagttaac
>.....gapB.....>
   t t q g r f d g k v e v k d g g f e v n
481 ggtaaattcg ttaaagttac tgctgaatct aaccagcta acatcaactg ggctgaagtt
>.....gapB.....>
   g k f v k v t a e s n p a n i n w a e v
541 ggtgcagaaa tcgttcttga agcaactggt ttcttcgcaa ctaaagaaaa agctgaacaa
>.....gapB.....>
   g a e i v l e a t g f f a t k e k a e q
601 cacttgcacg ctaatggtgc taagaaagtt gttatcactg cacctggtgg atcagatggt
>.....gapB.....>
   h l h a n g a k k v v i t a p g g s d v
661 aaaacaatcg ttttcaacac taaccacgaa gtacttgatg gaactgaaac agtaatttca
>.....gapB.....>
   k t i v f n t n h e v l d g t e t v i s
721 gctggttcat gtacaaccaa ctgtcttgct ccaatggctg atactttgaa caaacaattc
>.....gapB.....>
   a g s c t t n c l a p m a d t l n k q f
781 ggtatcaaag ttggtacaat gactacagtt cacggttaca ctggtgacca aatgactctt
>.....gapB.....>
   g i k v g t m t t v h g y t g d q m t l
841 gatggcccac accgtggtgg agatttccgt cgcgcacgtg ctgcagctga aaacatcgta
>.....gapB.....>
   d g p h r g g d f r r a r a a a e n i v
901 cctaactcaa caggtgctgc taaagccatc ggtcttgat tgccagaact tcaaggtaaa
>.....gapB.....>
   p n s t g a a k a i g l v l p e l q g k

```

Figure 12B

```

961  cttcaaggac atgctcaacg tgtaccagtt ccaactgggtt cattgactga acttggtact
>.....gapB.....>
   l q g h a q r v p v p t g s l t e l v t

1021  atccttgata aagaagttac agttgacgaa atcaacgcag ctatgaaagc tgcttcaaat
>.....gapB.....>
   i l d k e v t v d e i n a a m k a a s n

1081  gaatcatttg gttacaacga agaccaaadc gtttcatctg atatcggttg tatctcaaac
>.....gapB.....>
   e s f g y n e d q i v s s d i v g i s n

1141  tcttcaactct ttgatgctac tcaaactgaa gttacttcag ctaacggagc tcaacttggt
>.....gapB.....>
   s s l f d a t q t e v t s a n g a q l v

1201  aaaactgtat cttggtacga taacgaaatg tcatacactt caaaccttgt tcgtacactt
>.....gapB.....>
   k t v s w y d n e m s y t s n l v r t l

1261  gcatacttcg ctaaaatcgc taaataagga ggaaaaaatg aagaagaaaa tcattagtgc
>.....gapB.....>
   a y f a k i a k
                                     >>..IRrpmD..>>
                                               >>.....SSusp45.....>
                                               m k k k i i s

1321  catcttaatg tctacagtga ttctttcagc tgcagctcct ttatcaggcg tttatgcatt
>.....SSusp45.....>
   a i l m s t v i l s a a a p l s g v y a
                                               pins >>

1381  tgtgaaccaa cacctgtgcg gctcacacct ggtggaagct ctctacctag tgtgccccga
>.....pins.....>
   f v n q h l c g s h l v e a l y l v c g

1441  acgaggcttc ttctacacac ccaagaccog ccgggaggca gaggacctgc aggtggggca
>.....pins.....>
   e r g f f y t p k t r r e a e d l q v g

1501  ggtggagctg ggcgggggcc ctggtgcagg cagcctgcag cccttggcc tggaggggtc
>.....pins.....>
   q v e l g g g p g a g s l q p l a l e g

1561  cctgcagaag cgtggcattg tgaacaatg ctgtaccagc atctgctccc tctaccagct
>.....pins.....>
   s l q k r g i v e q c c t s i c s l y q

1621  ggagaactac tgcaactaat tttccgattt taacgtata aaaaccagtc ttcgggctgg
>.....pins.....>
   l e n y c n -

```

Figure 13A

```

1 gatggctgaa gctccaactc atgaacaagt tgaccaatggt gtggatacaa ttgttgaagt tgttgaagag gaaattgggtg tgaataaaag aaaagacaag
>>...../femD.....>>

101 gagaatattc ttcttgctt ttttcatac ctaaaactc acctactgtg gtagagttt ttatctttt ttggcgtcta gaaactctg taaaacgaaa
<<.....treR.....<<

201 acggtcaacc tgatgctg atcagata ctgaaaaagt gtattatcgg caagatagac atgagattc acgaaaaaa catgatggtc ctccggattt
<.....treR.....<

301 aaatcaagat atgtaaaatc atcttcacaa gcaaaatcaa tggtaacttc tttttggca taggcaatat caagtcocaa agccccctt aaataatcgt
<.....treR.....<

401 aagtagaatt ttgggcatgt gcgggggtca aaccatcagc gtatttttct aaaaataaat cccaatcaa aatggaaaat ttaccatcta ctttcttct
<.....treR.....<

501 tctaagaata ctaagggctt ggtcgcgat ggcgaatcca gtagttctg aaagagctgg ggtaatttt atactttcaa atttattac ttcagtttca
<.....treR.....<

601 ctgtgaaaac ccattgaagt ttgcaattct ttatatgaag ttaagcggaa aatagggaaa aggagcogat cgtgagcgag gacaatgctg ccatagccat
<.....treR.....<

701 gtcttctttg gatgagccct ttttcttcta aaatttttaa agcttgctg acggttgaac ggctactttc ataactaata gaaagtctat tctcgtttgg
<.....treR.....<

801 aagaatatcg ttcgtttttat agatatcatt aaaaatcttt ttttctaaat cttgcaaaat cacttcatat ttcttcatac ttatatattt atcataaaaa
<.....treR.....<<

901 taattgttaa cgcttgctga aaacgtttt atgaaaacgc cttaaaatgg cattttgact tgcaaaactgg gctaaagatt gctaaaaatga aaaatgccta
>>.....PhIIA.....>>

1001 tgtttaaggt aaaaaacaaa tggaggacat ttctaaaatg ttggaatag gaaaaaagaa agaattgaga gatgataaaa gcctttatgc tccagtttct
>.....PhIIA.....>>
>>.....ptsI.....>>

1101 ggggaagtt tcaaccttc aacagtcaac gaccccgat ttccaacaaa gataatggga gacgggttctg cggttgagcc aaaatttttg
>.....ptsI.....>

```

Figure 13B

```

1201 cccagtttc tgcAAAagta actttggttc aaggacaatgc aattggtttt aaacgtgctg atggcctaga tgtactttta catcttggaa ttgatacagt
>.....PtsI.....>
1301 agctcttaaa ggtcttccatt ttaaaaatcaa ggtcaaaagtt gatgatattg tcaatggtgg tgatgagott ggaagcgttg attgggcaca gattgaagct
>.....PtsI.....>
1401 gcaggttttag ataaaacgac aatggttatc ttacaaata caaaagataa actctctgag ttcaaatgca attatggacc agctacttct ggaagtgaac
>.....PtsI.....>
1501 ttggttaaggc aagtgttaaa taaggaggaa aaaatggcaa attattcaca acttgggaca gaaattatcg caaatgtagg tggcgtgag aatgtcacia
>.....Pts I.....>>
>>.IRrpmD.>>
>>.....PtsII.....>
1601 aagttattca ctgtatcact cgtcttcggt ttaccttgaa agacaagat aaagcagata cggcggcgat tgaagcotta cctgggtgctg ctggagctgt
>.....PtsII.....>
1701 ttataactca aacttgaatc aatatcaagt agttattgga caagctgtag aagatgttta tgacgaggtt gttgaacagc ttggagattc agttgttgat
>.....PtsII.....>
1801 gaagatgcaa cggcgcaagc acttactgca acagcaccgg ctagtggtaa aaaacaaaat ccaattgttc atgctttcca agtggttatt gggacaatta
>.....PtsII.....>
1901 caggttcgat gattccaatt attggtttac ttgcggctgg tgggatgatt aatggattat taagtatctt tgttaaagga aatcgtttaa ttgaagtgat
>.....PtsII.....>
2001 tgaccctgca agttcaactt acgtcattat ctcaactcta gcaatgacac cattttattt ctacctgtt ttagtaggat ttccagcagc aaaacaatta
>.....PtsII.....>
2101 gcacctaaag atactgtttt acaatttatt ggtgctgctg ttggtggtt catgattaat ccagggatta ctaacttggc aatgctcat gttggaacaa
>.....PtsII.....>
2201 atgcggccgg taaaaatgtt gttgttgaag cagcagctcc agtagcaaat ttccctggag tcaactttaa tacaagttat tttggaattc cggttgcttt
>.....PtsII.....>
2301 gccaaattat gcttatacaa ttttcccaat cattgtggcg gtagcaatcg ctaaaccctt gaatgcttgg ttgaaaaagg ttttaccact tgccttgcgt
>.....PtsII.....>

```

Figure 13C

```

2401 ccaattttcc aaccgatgat tactttcttc atcactgctt caatcatttt actctttggtc ggtcctgtta tttcaacaat ttcactctggt ttgtcatttcg
>.....ptsII .....>
2501 ttattgacca tatcttgtca ttaaaacttag ggattgcaag tattatcgc ttttggtttgt atcaatgttt gtttatattt ggtttgcaact ggttggttgt
>.....ptsII .....>
2601 accacttatt tcacaagagt tggcagcaac aggagcaagc tcacttaata tgattgttag ctccacaatg ctgcgcaag gagttggtgc cttgactgtc
>.....ptsII .....>
2701 ttctttaaat ctaaaaaaagc tgaccttaaa ggactttctg ctccagctgc catttcggct ttttgtggag taactgaacc tgccatgtac ggaattaact
>.....ptsII .....>
2801 tgaaatatgt tcgctcttc atcatgtctt caattggtgc agcaattggt gctgggattg cgggatttgg tggcttaca atgtttggat tttcagggtc
>.....ptsII .....>
2901 attgattagt tttccctaact ttatctctaa tccattgacg catcatgcac ctgctgggtaa cttaatgctc tcttggattg ccaactgcggt atgtgctgtt
>.....ptsII .....>
3001 gccactttct tattagtttg gttcttttgg tacaaggata ctgatgtcat gggacaagga gttgaacaaa aaaatgcatt taaggatgct gtaaaataaa
>.....ptsII .....>
3101 tagtttttgc cttataaaag ttttgatata aggatttaca attatttttt gataaaaaaa ttaactgatag aaatgaaaaa aattctgtca gtaattttgg
3201 aaagtcattc taaaaaattc attttaaaat gacgagaaaag aaggtaaaaa gatgttttaa gcagttattgt ttgattttaga tggcgtaat
>.....pgmB/.....>

```

Figure 14A

```

1  gtaattctaa tgctggtagg aatacaaaatt caggcactag tactggaat actggaggaa caactactgg tggtagcgg ataaatagtt caccaattgg
>>...../usp45.....>
101 aaatccttat gctggtagtg gatgtactga ctatgtatgg caatactttg ctgcacaagg aatttatatc agaaatatca tgcctggtaa tggtaggaaa
>...../usp45.....>
201 tgggcttcta atggacctgc ccaaggcgtg ctccatgttg taggagctgc tctgggtgtt atcgcataca gcttctcagc tgattttgtt ggatatgcaa
>...../usp45.....>
301 actcacotta cggtcacgta gctattgtaa aatcagttaa ttcagatggt acaattacta tcaaaagaagg cggatatggt acaacttgggt ggggacatga
>...../usp45.....>
401 acgtactgta agtgcgtctg gtgttacttt cttgatgcca aactaaggag gaaaaaatga cagaaccgtt aaccgaaacc cctgaactat ccgcgaaata
>...../usp45.....>
>>.IRrpmD.>>
>>.....OtsB.....>
501 tgcctggttt tttgatcttg atggaacgct ggcggaaatc aaaccgcatc ccgatcaggt cgctcgtcct gacaatattc tgcaaggact acagctactg
>.....OtsB.....>
601 gcaaccgcaa gtgatgggc attggcattg atatcagggc gctcaatggt ggagcttgac gactggcaa aaccttatcg cttcccgtta gcgggcgtgc
>.....OtsB.....>
701 atggggcgga gcgccgtgac atcaatgta aaacacatat cgttcatctg ccggatcga ttgcgcgtga tattagcgtg caactgcata cagtcactgc
>.....OtsB.....>
801 tcagtatccc ggcgcggagc tggaggcгаа agggatggt tttgcgctgc attatcgtca ggctccgcag catgaagacg cattaatgac attagcgcaa
>.....OtsB.....>
901 cgtattactc agatctggcc acaaatggcg ttacagcagg gaaagtgtg ttgcgagatc aaaccgagag gtaccagtaa aggtgaggca attgcagcctt
>.....OtsB.....>
1001 ttatgcagga agctcccttt atcggggcgaa cgcccgtatt tctgggcgat gatttaaccg atgaatctgg cttcgcagtc gttaaccgac tgggcggaaat
>.....OtsB.....>
1101 gtcagtaaaa attggcacag gtgcaactca gcatcctgg gcactggcg gtgtgccgga tgtctggagc tggcttgaat tgataaccac cgattacaaa
>.....OtsB.....>

```

Figure 14B

```

1201 caaaaaagag aaaataacag gagtgatgac tatgagtcgt ttagtcgtag tatctaaaaa aaagtcttaa taaataaaaa atagtggttt gatagtggg
>.....OtsB.....>
1301 aataattttc cttctgtcaa atcattttttt attattgtgg tataataata aggaaaaaatg ataaggggat agatacaaat gtgtggaatt gtcggcttta
>>.....asnH/.....>
1401 ttgaccggat cgatcaaaat gataaatcaa aaactttaga agaatgatg gatacaatcg ctcaaccgag tccaagtagt tcaggtgaat ttattgacga
>.....asnH/.....>
1501 aggagcagca attggtttc gtcgcctgag tattattgac cttgagggtg gagatcaacc tatctttaat gaagataaaa ctaaacttat aacctttaat
>.....asnH/.....>
1601 ggcgaaattt ataatttccg tgaattgcgt gaagacctta tctctaaagg tcatgatttt actactcatg ctgatacaga agtgotttta catggttacg
>.....asnH/.....>

```

Figure 15A

```

1  caccgaatta acacgcatta tgacttaacg aggcaattac ctacgggtcta ttgacagaa cgtttaacag atctcgttta tcaacgttcc aactaaaaa
>>...../transcriptional.....>>

101 gccaaatctgg ctttttttcta tgctctgtcg ttctaatagg tttgatatct aaaaataaaa aagttaaatt gagatacaaa atataaattat caaggctgaa

201 cctcgcaagc ttaaaggaaa cttatatgac aattttggta caggagtctt caaaagtggc acagaaccaa agtgatgaaa aaataagaaa ctgcttttctt

301 tactttgcct attaatgcta taatgaaaat gtagaaaaga tggacgtgaa accagttcat caaaaaaagt aaaggagact gttcaacctt gaacaatttt
>>..ptcC/...>
m n n f

401 attcaaaaaa aaatcatgcc tccaatgatg aaatttttga ataccctgyc agtcaacggca atcaaaaaatg gtatgtgaat tcctatccca ttatcatta
>.....ptcC/.....>
tga30
          ECORI
i q n k i m p p m k f l n t r a v t a i k n g m - i p i p f i i

501 ttggttcagt attcttgatt cttggtcaac tgcattcca agcaggacaa gacttcatga acaaaatcaa attgggccc ctccttttac aaattaataa
>.....ptcC/.....>
i g s v f l i l g q l p f q a g q d f m n k i k l g p l f l q i n

601 tgcttcattt ggtattatgg ctttgcttgc cgtgttcggt attgcttacg cttgggttcg agatgcaggt tatgaaggag taccggctgg tttaacaggt
>.....ptcC/.....>
n a s f g i m a l l a v f g i a y a w v r d a g y e g v p a g l t g

701 gtcattgttc acatcttgtt gcaaccagac acaatccatc aagtaacaag tgttactgac ccaactaaa catcaacagc atttcaagta ggtggtgtca
>.....ptcC/.....>
v i v h i l l q p d t i h q v t s v t d p t k t s t a f q v g v

801 ttgaccgagc ttggttaggt gggaaaggga tggttctctc aatcatcgtt ggactcttag taggttggat ttactactgac tttatgcgtc ggaacatcac
>.....ptcC/.....>
i d r a w l g g k g m v l s i i v g l l v g w i y t g f m r r n i

901 aatcaaaaatg ccagaacaag ttccagaaaa cgttgccgca tcatttactt cacttgacc tgcaggagca atcattacaa tggctggtgt ggttcatgga
>.....ptcC/.....>
t i k m p e q v p e n v a a s f t s l v p a g a i i t m a g v v h g
    
```

Figure 15B

```
1001 atcacaacga ttggcttcaa cacaacttt  
>.....ptcc/.....>>  
i t t i g f n t t
```

Figure 16

```

1  tcagctaacy gagctcaact tgttaaaact gtatcttggt acgataaacy aatgtcatac acttcaaacc ttgttcgtac acttgcatatc ttcgctaaaa
>...../gapB.....>
101 tcgctaaata aggaggaaaa aatgaagaag aaaatcatta gtgccatctt aatgtctaca gtgattcttt cagctgcagc tcctttatca ggcgctttatg
>.. /gapB..>>
>>.IRrpmD.>>
>>.....SSusp45.....>
201 catttgtgaa ccaacacctg tgcggctcac acctggtgga agctctctac ctagtgtgcg gggaacgagg cttcttctac acaccaaga cccgccggga
>> SSusp45
>>.....pins.....>
301 ggcagaggac ctgcaggtgg ggcaggtgga gctggggcggg ggccttggtg caggcagcct gcagcccttg gccctggagg ggtccctgca gaagcgtggc
>.....pins.....>
401 attgtggaac aatgctgtac cagcatctgc tcctctacc agctggagaa ctactgcaac taattttccg attttaacgg tataaaaaacc agtcttcggg
>.....pins.....>>

```

Figure 17

```

1  aatccaatga cggcacttct tccttggacg acaccagcac ctgtgagaat ggccatttca ggtggacttc catttttgat tatttttgca atctgtttag
   >>.....'PTS.....>
101 tcttgaatgt tcttatttac taccatttct ttaagggtggc gtataataaa gccttagaag aagaaaaagc agctgttgaa ttagaggggt cagaaaactgc
   >.....'PTS.....>
201 ctgatggaaa acgccttaaa atggcatttt gacttgcaaa ctgggctaag atttgctaaa atgaaaaatg cctatgttta aggtaaaaaa caaatggagg
   >> ./PTS
   >>.....PhIIA.....>
301 acattttctaa aatgaaaaaa aagattatct cagctatttt aatgtctaca gtgatacttt ctgctgcagc cccgttgtca ggtgtttacy cctcagctgg
   >..PhIIA.>>
   >>.....SSusp45.....>
   hIL10 >>.....>
   s a
401 tcaaggtact caatcagaaa actcatgtac tcactttcca ggtaacttgc caaacatgct tcgtgatttg cgtgatgctt tttcacgtgt taaaactttt
   >.....hIL10.....>
501 ttccaatga aagatcaact tgataacttg cttttgaaag aatcactttt ggaagatttt aaaggttacc ttggttgtca agctttgtca gaaatgatcc
   >.....hIL10.....>
601 aattttacct tgaagaagtt atgccacaag ctgaaaacca agatccagat atcaaaagctc acgttaactc atggggtgaa aaccttaaaa ctttgcgtct
   >.....hIL10.....>
701 tcgtttgcgt cgttgtcacc gttttcttcc atgtgaaaac aaatcaaaag ctgttgaaca agttaaaaac gcttttaaca aattgcaaga aaaaggtatc
   >.....hIL10.....>
801 tacaaaagcta tgtcagaatt tgatatcttt atcaactaca tcgaagctta catgactatg aaaatccgta actaaactaga attaatctat aagttactga
   >.....hIL10.....>
901 caaaactgct agtaactttt tttgtgggaa aaatgtattt ttatgaccgt aaagaatctg tcagtagaag tctgaaatc gtttaaaaaa cgactagaat

```

Figure 18

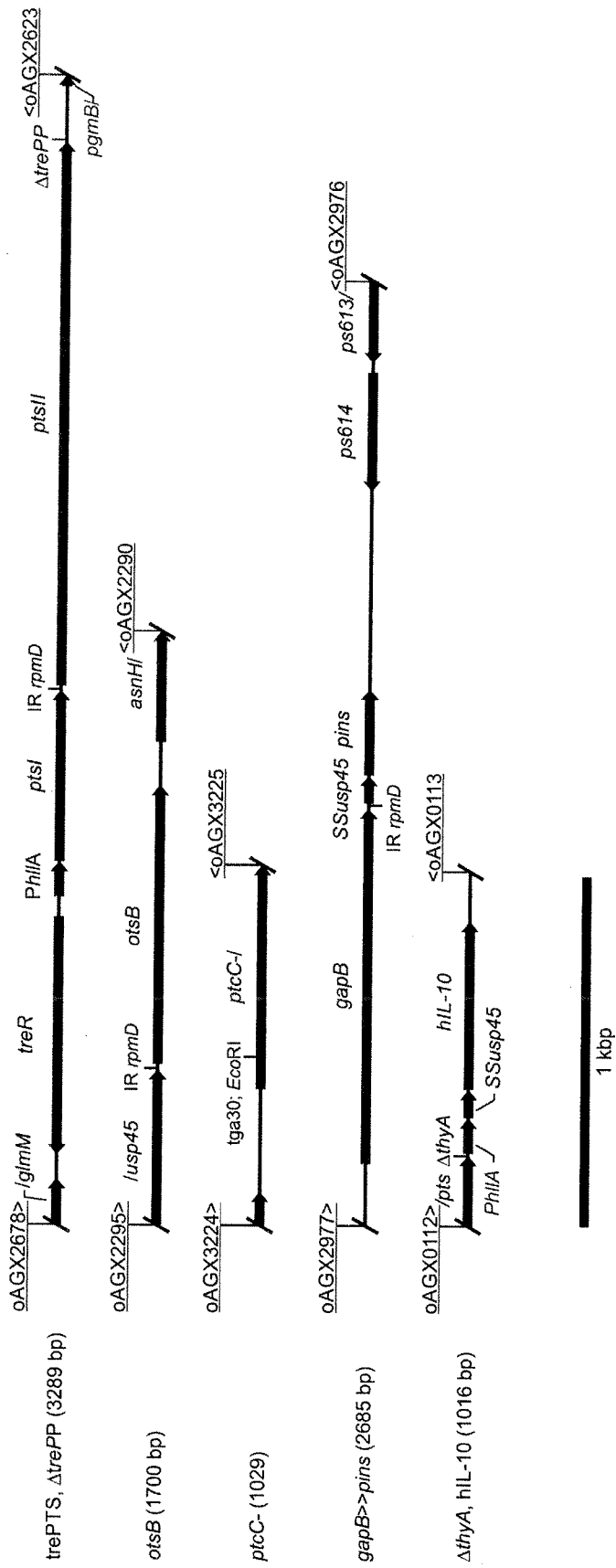

INTERNATIONAL SEARCH REPORT

International application No
PCT/IB2017/055287

A. CLASSIFICATION OF SUBJECT MATTER
INV. A61K39/008 A61K35/744 C12N15/74
ADD.

According to International Patent Classification (IPC) or to both national classification and IPC

B. FIELDS SEARCHED

Minimum documentation searched (classification system followed by classification symbols)
A61K C12N

Documentation searched other than minimum documentation to the extent that such documents are included in the fields searched

Electronic data base consulted during the international search (name of data base and, where practicable, search terms used)

EPO-Internal, CHEM ABS Data, EMBASE, WPI Data

C. DOCUMENTS CONSIDERED TO BE RELEVANT

Category*	Citation of document, with indication, where appropriate, of the relevant passages	Relevant to claim No.
X	WO 03/064607 A2 (SYMBIGENE INC [US]; CHEN WEI [US]; FU XIAOLI [US]; NOURAINI SHERRY [US] 7 August 2003 (2003-08-07)	1-26
Y	abstract; claims 1,4-9,11,13,20 paragraphs [0106], [0109]	1-26
X	TATIANA TAKIISHI ET AL: "Reversal of autoimmune diabetes by restoration of antigen-specific tolerance using genetically modified Lactococcus lactis in mice", JOURNAL OF CLINICAL INVESTIGATION, vol. 122, no. 5, 1 May 2012 (2012-05-01), pages 1717-1725, XP55308282, US	1-26
Y	ISSN: 0021-9738, DOI: 10.1172/JCI60530 abstract page 1724, column 2, paragraph Methods	1-26

Further documents are listed in the continuation of Box C. See patent family annex.

* Special categories of cited documents :

"A" document defining the general state of the art which is not considered to be of particular relevance

"E" earlier application or patent but published on or after the international filing date

"L" document which may throw doubts on priority claim(s) or which is cited to establish the publication date of another citation or other special reason (as specified)

"O" document referring to an oral disclosure, use, exhibition or other means

"P" document published prior to the international filing date but later than the priority date claimed

"T" later document published after the international filing date or priority date and not in conflict with the application but cited to understand the principle or theory underlying the invention

"X" document of particular relevance; the claimed invention cannot be considered novel or cannot be considered to involve an inventive step when the document is taken alone

"Y" document of particular relevance; the claimed invention cannot be considered to involve an inventive step when the document is combined with one or more other such documents, such combination being obvious to a person skilled in the art

"&" document member of the same patent family

Date of the actual completion of the international search	Date of mailing of the international search report
5 December 2017	13/12/2017

Name and mailing address of the ISA/ European Patent Office, P.B. 5818 Patentlaan 2 NL - 2280 HV Rijswijk Tel. (+31-70) 340-2040, Fax: (+31-70) 340-3016	Authorized officer Celler, Jakub
----------------------------------------------------------------------------------------------------------------------------------------------------------------------	-----------------------------------------

INTERNATIONAL SEARCH REPORT

Information on patent family members

International application No

PCT/IB2017/055287

Patent document cited in search report	Publication date	Patent family member(s)	Publication date
WO 03064607	A2	07-08-2003	
		AU 2003210687 A1	02-09-2003
		AU 2003210689 A1	02-09-2003
		CN 1642579 A	20-07-2005
		CN 1642967 A	20-07-2005
		TW 200400829 A	16-01-2004
		TW 200404564 A	01-04-2004
		TW 200408410 A	01-06-2004
		US 2004043003 A1	04-03-2004
		WO 03063785 A2	07-08-2003
		WO 03064607 A2	07-08-2003
