

(19) World Intellectual Property Organization
International Bureau



(43) International Publication Date
6 August 2009 (06.08.2009)

PCT

(10) International Publication Number
WO 2009/095332 A1

(51) International Patent Classification:

A61M 5/315 (2006.01) A61M 5/31 (2006.01)
A61M 5/24 (2006.01)

(21) International Application Number:

PCT/EP2009/050590

(22) International Filing Date: 20 January 2009 (20.01.2009)

(25) Filing Language: English

(26) Publication Language: English

(30) Priority Data:

08100987.0 28 January 2008 (28.01.2008) EP

(71) Applicant (for all designated States except US): **NOVO NORDISK A/S** [DK/DK]; Novo Alle, DK-2880 Bagsværd (DK).

(72) Inventors; and

(75) Inventors/Applicants (for US only): **RADMER, Bo** [DK/DK]; Åvang 40, DK-3400 Hillerød (DK). **WIELANDT, Jakob Oest** [DK/DK]; Rønnebærvej 9, 4.th, DK-2400 Copenhagen Nv (DK). **JESPERSEN, Frank Andreas** [DK/DK]; Novo Nordisk A/s, Novo Allé, DK-2880 Bagsværd (DK). **MARKUSSEN, Tom Hede** [DK/DK]; Skovalléen 19, DK-2880 Bagsværd (DK). **JENSEN, Jacob Kollerup** [DK/DK]; Mølleåparken 109, 1., DK-2800 Kgs. Lyngby (DK).

(81) Designated States (unless otherwise indicated, for every kind of national protection available): AE, AG, AL, AM, AO, AT, AU, AZ, BA, BB, BG, BH, BR, BW, BY, BZ, CA, CH, CN, CO, CR, CU, CZ, DE, DK, DM, DO, DZ, EC, EE, EG, ES, FI, GB, GD, GE, GH, GM, GT, HN, HR, HU, ID, IL, IN, IS, JP, KE, KG, KM, KN, KP, KR, KZ, LA, LC, LK, LR, LS, LT, LU, LY, MA, MD, ME, MG, MK, MN, MW, MX, MY, MZ, NA, NG, NI, NO, NZ, OM, PG, PH, PL, PT, RO, RS, RU, SC, SD, SE, SG, SK, SL, SM, ST, SV, SY, TJ, TM, TN, TR, TT, TZ, UA, UG, US, UZ, VC, VN, ZA, ZM, ZW.

(84) Designated States (unless otherwise indicated, for every kind of regional protection available): ARIPO (BW, GH, GM, KE, LS, MW, MZ, NA, SD, SL, SZ, TZ, UG, ZM, ZW), Eurasian (AM, AZ, BY, KG, KZ, MD, RU, TJ, TM), European (AT, BE, BG, CH, CY, CZ, DE, DK, EE, ES, FI, FR, GB, GR, HR, HU, IE, IS, IT, LT, LU, LV, MC, MK, MT, NL, NO, PL, PT, RO, SE, SI, SK, TR), OAPI (BF, BJ, CF, CG, CI, CM, GA, GN, GQ, GW, ML, MR, NE, SN, TD, TG).

Published:

- with international search report
- before the expiration of the time limit for amending the claims and to be republished in the event of receipt of amendments

(54) Title: INJECTION DEVICE FOR PERFORMING MEDICAL INJECTIONS

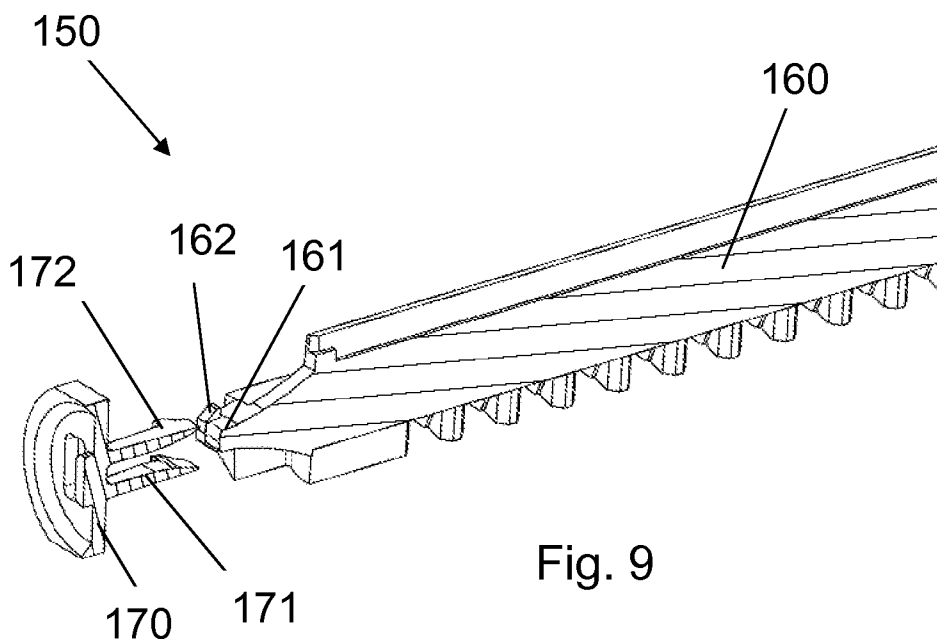

Fig. 9

(57) Abstract: The present invention concerns a prefilled injection device having a container and a dose setting mechanism encapsulated inside the housing. The injection device incorporates an axial variable connection such that the distance between the distal end of the piston rod means and the plunger is minimized preferably to zero.

WO 2009/095332 A1

INJECTION DEVICE FOR PERFORMING MEDICAL INJECTIONS

THE TECHNICAL FIELD OF THE INVENTION:

5 The invention relates to a variable connection for an injection device and preferably for a variable connection between the parts of an injection device determining the distance between the movable element in the container and the part moving the movable part.

DESCRIPTION OF RELATED ART:

10

People suffering from diabetes are often treated with multiple daily injections in a regimen comprising one or two daily injections of a long acting insulin to cover the basal requirement supplemented by bolus injections of a short or rapid acting insulin to cover requirements related to meals.

15

Generally speaking two different types of pen systems are used for the treatment of diabetes. The first type of system being injection devices with a replaceable cartridge containing the insulin to be injected. Often such cartridges contain 3 ml of insulin, and when this amount has been injected a new cartridge is inserted in the same injection device which therefore often is in use for several years. Such injections devices are usually referred to durable injection devices.

20

An example of such durable injection device where the cartridge is connected to the injection device by way of a bayonet coupling is e.g. disclosed in WO 99/16487.

25

The other type being injection devices containing a predetermined and non-replaceable amount of insulin, also often 3 ml. The insulin is often contained in a cartridge embedded in the injection device. When the predetermined amount has been injected which can take anywhere from a few days to a month, the entire injection device is discarded and a new injection device is used for subsequent injections. Such injection devices are often referred to as disposable or prefilled injection pens. The present invention lies within this type of injection devices.

30

An example of such prefilled injection pen where the two parts forming the housing is irreversible clicked together thereby encapsulating the container is known from US 6,004,297 and from WO 2008/003560.

5 When clicking the parts of an injection device together the tolerances must be calculated such that the click- or snap function will always be activated i.e. the tolerances must be such that the "point of no return" is always reached during assembly otherwise the injection device will fall apart. At the same time the distal end of the piston rod means must not be pressed against the plunger while this will pressurize the content in the cartridge with the result that
10 the liquid drug will start to flow from the injection device once an injection needle is mounted to the needle mount.

Not only does the individual parts making up the injection device come with certain tolerances, also when filling the liquid drug into the cartridge a certain tolerance obliges, both in
15 regard of the cartridge itself and in regard of the volume of the content, which results in a slightly different position of the plunger from one cartridge to another.

Due to these production tolerances there must always be sufficient space between the plunger of the cartridge and the distal end of the piston rod means of the dose setting and
20 injection mechanism to absorb the tolerances and to allow the "point of no return" to be reached during the assembly of the injection device in all cases.

As a result of this the assembled injection device will always be delivered to its final user with a distance between the plunger and the distal end of the piston rod means, a distance that
25 will vary for each single injection device. The user must therefore make an initial priming of the injection device before first use i.e. the user must perform one or more air shoots before the first use of the device such that the distal end of the piston rod means are moved into abutment with the rubber plunger.

30 For injection devices operating with large dose sizes this is critical, since the air shoots are based on the large dose size. When the user executes the last air shoot bringing the piston rod means into abutment with the plunger this shoot can be larger than the remaining distance between the piston rod means and the plunger resulting in a forward movement of the plunger and a significant loss of fluid drug.

35

DESCRIPTION OF THE INVENTION:

It is an object of the present invention to provide an injection device in which initial priming can be avoided.

5

By determining the distance between the distal end of the piston rod means and the plunger of the cartridge individually during assembly, the device can be assembled such that this distance is minimized, preferably minimized to zero such that the piston rod means abuts the plunger. The individual adjustment of this distance can be practised in many different ways, one way could be to have the piston rod means comprise two parts which can be adjusted relative to each other in the axial direction during assembly, another could be to have the housing comprise of two parts which can be adjusted relative to each other during assembly.

10

The piston rod means could e.g. be made from a piston rod and a piston rod foot which has an interface that can slide axially. Once the piston rod and the piston rod foot are slid into the correct position the two elements are permanently connected to each other, preferably by welding.

15

In one embodiment the piston rod foot is provided with a number of wings that engages a number of recesses in the piston rod, which recesses preferably has a sloping configuration such that the piston rod foot is urged in the distal direction.

20

In a different embodiment, the apparatus for performing medical injections comprises, a housing, a container containing the liquid medicament and a dose setting and injection mechanism for setting and injecting a dose of the liquid medicament,

25

The container and the dose setting and injection mechanism are encapsulated inside the housing, which comprises a first part and a second part locked together by a longitudinal variable connection.

30

By using a variable connection that can be locked in a variable position, the distance between the dose setting and injection mechanism and the container can be differentiated in each device and thereby minimized in accordance with the tolerances for the specific injection device.

The two parts is preferably permanently secured to each other in the variable position thereby permanently embedding the dose setting and injection mechanism and the container.

- 5 The dose setting and injection mechanism comprises the piston rod and the container comprises a plunger, and the distance between these two parts are, according to the invention sought minimized.

10 The two parts making up the housing is permanently locked to each other when the piston rod and the plunger are in abutment thereby setting the distance between the piston rod means and the plunger top zero.

15 When the distance between the distal end of the piston rod means and the plunger are based on a relative axial movement between the parts making up the housing, the method comprises the steps of:

- (i) Bringing the piston rod means in abutment with the plunger,
- (ii) Securing the first part of the housing and the second part of the housing in this position.
- 20

Whereas when the axial distance is based on a relative axial movement between the parts making up the piston rod means, the method comprises the steps of:

- 25 (i) Bringing the piston rod means in abutment with the plunger,
- (ii) Securing the piston rod means in this position.

30 As an alternative to providing the relative axial movement between the piston rod and the piston rod foot, the piston rod means can be telescopic and locked together during the assembly.

The system that makes up a prefilled injection device usually comprises two parts, a dose setting and injection mechanism which are contained in a first body part of the housing and a

cartridge which is embedded in a second body part of the housing, often referred to as the cartridge holder.

According to the present invention this system further comprises means for varying the distance between the piston rod means of the dose setting and injection part and the plunger of the cartridge holder part.

These means can be provided in the piston rod means such as between the piston rod and the piston rod foot or alternatively be provided between the first body part and the second body part of the housing.

These detailed described embodiments do not exclude other ways of incorporating the means for varying the distance in an injection device.

DEFINITIONS

An "injection pen" is typically an injection apparatus having an oblong or elongated shape somewhat like a pen for writing. Although such pens usually have a tubular cross-section, they could easily have a different cross-section such as triangular, rectangular or square or any variation around these geometries.

As used herein, the term "drug" is meant to encompass any drug-containing flowable medicine capable of being passed through a delivery means such as a hollow needle in a controlled manner, such as a liquid, solution, gel or fine suspension. Representative drugs includes pharmaceuticals such as peptides, proteins (e.g. insulin, insulin analogues and C-peptide), and hormones, biologically derived or active agents, hormonal and gene based agents, nutritional formulas and other substances in both solid (dispensed) or liquid form.

Correspondingly, the term "subcutaneous" injection is meant to encompass any method of transcutaneous delivery to a subject.

Further the term "injection needle" defines a piercing member adapted to penetrate the skin of a subject for the purpose of delivering or removing a liquid. An "injection needle" usually comprises a "needle cannula" and a "hub". The term "Needle Cannula" is used to describe the actual conduit performing the penetration of the skin during injection. A needle cannula is usually made from a metallic material such as stainless steel and connected to a hub to form

an injection needle assembly. A needle cannula could however also be made from a polymeric material or a glass material. The "hub" being the part in which the needle cannula is mounted carries the connecting means for connecting the needle cannula to an injection apparatus. A hub is usually moulded from a suitable thermoplastic material. An "injection needle" is also sometime referred as a "needle assembly" i.e. comprising a needle cannula mounted in a hub as supplied to the user.

"Cartridge" is the term used to describe the container containing the liquid drug e.g. insulin. Cartridges are usually made from glass but could also be moulded from any suitable polymer. A cartridge or ampoule is preferably sealed at one end by a pierceable membrane which can be pierced e.g. by an injection needle. The opposite end is closed by a plunger made from rubber or a suitable polymer. The plunger can be slidably moved inside the cartridge. The space between the pierceable membrane and the movable plunger holds the liquid drug which is pressed out as the plunger decreased the volume of the space holding the liquid drug.

"Piston rod means" is the term used to describe the mechanical element that transfer force from the dosing mechanism to the plunger inside the cartridge thereby moving the plunger forward. The "piston rod means" usually comprises a piston rod and a piston rod foot which is typically the element abutting the plunger. The piston rod and the piston rod foot can be made as two separate pieces or they can be made as one integral element. The "piston rod means" could also only be the piston rod without any foot in which case the piston rod would abut directly on the plunger.

All references, including publications, patent applications, and patents, cited herein are incorporated by reference in their entirety and to the same extent as if each reference were individually and specifically indicated to be incorporated by reference and were set forth in its entirety herein.

All headings and sub-headings are used herein for convenience only and should not be construed as limiting the invention in any way.

The use of any and all examples, or exemplary language (e.g. such as) provided herein, is intended merely to better illuminate the invention and does not pose a limitation on the scope of the invention unless otherwise claimed. No language in the specification should be construed as indicating any non-claimed element as essential to the practice of the invention.

The citation and incorporation of patent documents herein is done for convenience only and does not reflect any view of the validity, patentability, and/or enforceability of such patent documents.

5 This invention includes all modifications and equivalents of the subject matter recited in the claims appended hereto as permitted by applicable law.

BRIEF DESCRIPTION OF THE DRAWINGS:

10 The invention will be explained more fully below in connection with a preferred embodiment and with reference to the drawings in which:

Figure 1 shows a cross section of the injection device.

Figure 2 shows a perspective view of an assembly of the housing.

15

Figure 3 shows a cross sectional view of an alternatively assembly of the housing.

Figure 4 shows a perspective view of an alternatively assembly of the housing.

20

Figure 5 shows a perspective view of an alternatively assembly of the housing.

Figure 6 shows a cross sectional view of the piston rod means prior to assembly.

Figure 7 shows a cross sectional view of the piston rod means in one assembled position.

25

Figure 8 shows a cross sectional view of the piston rod means in a different assembled position.

30

Figure 9 shows a view of the piston rod means.

Figure 10 show a cross section of the injection device during assembly.

The figures are schematic and simplified for clarity, and they just show details, which are essential to the understanding of the invention, while other details are left out. Throughout, the same reference numerals are used for identical or corresponding parts.

5 DETAILED DESCRIPTION OF EMBODIMENT:

When in the following terms as “upper” and “lower”, “right” and “left”, “horizontal” and “vertical”, “clockwise” and “counter clockwise” or similar relative expressions are used, these only refer to the appended figures and not to an actual situation of use. The shown figures are
10 schematic representations for which reason the configuration of the different structures as well as there relative dimensions are intended to serve illustrative purposes only.

In that context it may be convenient to define that the term “distal end” in the appended figures is meant to refer to the end of the injection device carrying the injection needle whereas
15 the term “proximal end” is meant to refer to the opposite end pointing away from the injection needle.

Figure 1 discloses a pen shaped injection device 1 comprising a housing 10 formed from two parts 20, 30. A first part 20 holding the cartridge 40 and a second part 30 comprising a dose
20 setting and injection mechanism which comprises a piston rod means 50.

The cartridge 40 which contains the liquid medicament to be expelled is at a first end 41 provided with a membrane 42 which is pierceable by a not shown injection needle and a second end 43 which is locked by a movable plunger 44. When a user activates the dose setting and
25 injection mechanism to set and inject a dose, the piston rod means 50 is moved forward into contact with the plunger 44 which it then continues to move forward thereby expelling the set dose through the injection needle.

The first part 20 is at its proximal end provided with a number of outwardly pointing ratchet
30 teeth 21 which as disclosed in figure 2 can surround the entire periphery of the first part 20. The second part 30 is at its distal end provided with corresponding inwardly pointing ratchet teeth 31. Instead of providing the inwardly pointing ratchet teeth 31 and the outwardly pointing ratchet teeth 21 around the entire periphery, the teeth 21, 31, could be provided only on a
part of the periphery.

35

When the proximal end of the first part 20 enter the distal end of the second part 30 in order to assemble the housing 10, the outwardly pointing ratchet teeth 21 engages the inwardly pointing ratchet teeth 31 on the second part 30 thereby preventing the two part 20, 30 from being separated. The two parts 20, 30 can be variable adjusted relatively to each other such
5 that the distance X between the piston rod means 50 and the plunger 44 can be minimized.

Once the first part 20 and the second part 30 is in a position where a satisfactory distance X is obtained the two parts 20, 30 can be irreversible locked to each other. This irreversible locking can be performed in a number of different ways.
10

In figure 2 the two parts 20, 30 are permanently secured to each other by deforming zones 32 of the second part 30. This deformation can be done by pressure or by heat deformation.

A solution based on a counter nut 60 is disclosed in figure 3. The first part 20 and the second part 30 is provided with engaging threads 22, 33 such that the two parts 20, 30 are moved closer to each other when rotated. When the final position is reached, the counter nut 60 is screwed in the distal direction until it abuts the first part 20 thereby locking the two parts 20, 30 together.
15

In the embodiment disclosed in figure 4, the first part 20 is provided with a number of outwardly pointing protrusions 23 and the second part 30 is provided with a number of axially located ribs 34. When the two parts are rotated relatively to each other the protrusions 23 penetrates through the ribs 34 as disclosed in the close-up figure, thereby locking the two parts 20, 30 to each other.
20

In the embodiment disclosed in figure 5, the first part 20 is provided with an axially extending rib 24 which during assembly engages a longitudinal slit 35 in the second part. Once the first part 20 and the second part 30 is in their final position minimizing the distance between the piston rod 50 and the rubber plunger 44 preferably to zero the two parts are attached to each other by welding the axially extending rib 24 to the second part 30 by applying heat such that the axially extending rib 24 melts in the slit 35. Alternatively glue could be applied thereby gluing the parts 20, 30 together.
25
30

The figures 6 to 10 disclose an alternative way of minimizing the distance between the piston rod means 150 and the plunger 144. In the disclosed embodiment the piston rod means 150
35

comprises a piston rod 160 and a piston rod foot 170. The piston rod foot 170 is provided with a number of resilient attaching wings 171 pointing in the proximal direction and the piston rod 160 is provided with a number of recesses 161 for receiving the attaching wings 171. These recesses 161 have a sloping configuration sloping towards the distal end of the piston rod 160 such that the piston rod foot 170 will slide in the proximal direction when the piston rod foot 170 is mounted on the piston rod 160. Further the piston rod 160 is provided with a number of protrusions 162 engaging a number of barbs 172 on the piston rod foot 170 when it is in its most distal position thereby preventing the piston rod foot 170 from being automatically separated from the piston rod 160.

The cartridge holder 20, 120 could in all the embodiments be provided with an opening or window as indicated in figure 4, 5 and 10 through which the liquid drug in the cartridge 40, 140 can be viewed.

When an injection device is assembled the piston foot 170 is axially pushed onto the piston rod 160 as disclosed in figure 6 to 9. Once the correct relative position between the piston rod foot 170 and the piston rod 160 is obtained a laser beam 180 is directed towards the attaching wings 171 such that a melting zone 181 between the attaching wings 171 of the piston rod foot 170 and the recesses 161 of the piston rod 161 is obtained thereby melting the piston rod foot 170 and the piston rod 160 together. Although laser welding is described in this application a number of alternative methods for attaching the two parts 160, 170 can be used. The piston rod foot 170 and the piston rod 160 could e.g. be attached to each other through a variable mechanical connection such as a threaded connection or a telescopic mechanism; alternatively the two parts 160, 170 could be glued together in their final position.

During assembly the usual procedure as disclosed in figure 10 would be first to assemble the dose setting and injection mechanism, thereafter attaching the piston rod foot 170 on the piston rod 160 and finally to press the cartridge holder 120 with the cartridge 140 into the position in which the cartridge holder 120 locks to the main body 130. The plunger 144 of the cartridge 140 will then move the piston rod foot 170 in the proximal direction relatively to the piston rod 160. Once the injection device is fully assembled, the piston rod foot 170 will abut the plunger 144 due the sloping interface between the piston rod foot 170 and the piston rod 160. In this abutting position the laser welding is performed through openings 131 in the main

body 130 thereby locking the piston rod foot 170 to the piston rod 160 in a position where the piston rod foot 170 abuts the plunger 144 such that initial priming can be avoided.

5 Some preferred embodiments have been shown in the foregoing, but it should be stressed that the invention is not limited to these, but may be embodied in other ways within the subject matter defined in the following claims. The figures e.g. disclose the injection device of the present invention in the form of an oblong pen-shaped object, however, this particular shape is in no way limiting for the present invention as defined in the claims.

CLAIMS:

1. An injection device for performing medical injections comprising,

5 a container (40, 140) containing a liquid drug and a piston rod means (50, 150),

wherein the container (40, 140) comprises a distal end closed by a membrane (42) and a proximal end closed by a movable plunger (44, 144) which is movable in the distal direction by the piston rod means (50, 150) in order to expel the liquid drug contained between the
10 membrane (42) and the movable plunger (44, 144), characterized in that, the relative axial position between the piston rod means (50, 150) and the plunger (44, 144) is determined during assembly of the injection device.

2. An injection device according to claim 1, characterized in that, the relative axial position is
15 determined such that the piston rod means (50, 150) and the movable plunger (44, 144) abuts each other.

3. An injection device according to claim 1 or 2, characterized in that, the piston rod means (50, 150) comprises a piston rod (160) and a piston rod foot (170).
20

4. An injection device according to claim 3, characterized in that, the piston rod foot (170) is a separate part attached to the piston rod (160).

5. An injection device according to claim 3 or 4, characterized in that, the axial distance be-
25 tween the piston rod foot (170) and the plunger (44, 144) is determined during assembly.

6. An injection device according to claim 5, characterized in that, the relative axial position is determined such that the piston rod foot (170) and the movable plunger (44, 144) abuts each other.
30

7. An injection device according to claim any of claims 3 to 6, characterized in that, the piston rod foot (170) has a number of resilient attaching wings (171) pointing in the proximal direction which wings (171) are received in a number of recesses in the piston rod (161).

8. An injection device according to claim 1, characterized in that, the injection device further comprises a dose setting and injection mechanism for setting and injecting a dose of the liquid drug, and wherein the container (40, 140) and the dose setting and injection mechanism is encapsulated in a housing (10), which housing (10) comprises a first part (20) and a second part (30) locked together by a longitudinal variable connection.

9. An injection device according to claim 8, characterized in that, the longitudinal variable connection between the first part (20) and the second part (30) comprises means allowing the two parts (20, 30) to be locked together in a variable position.

10

10. An injection device according to claim 9, characterized in that, the two parts (20, 30) are permanently secured to each other in the variable position.

11. An injection device according to claim 10, characterized in that, the dose setting and injection mechanism comprises the piston rod means (50, 150) and the container (40, 140) comprises the movable plunger (44, 144).

12. An injection device according to any of the claims 8 to 11, characterized in that, the piston rod means (50, 150) and the plunger (44, 144) are in abutment when the two parts (20, 30) are permanently secured to each other.

13. A method of assembling an injection device according to any of the claims 8 to 12, the method comprising the steps of:

(i) Bringing the piston rod means (50, 150) in abutment with the plunger (44, 144)

(ii) Securing the first part (20) and the second part (30) of the housing (10) in this position.

14. A method of assembling an injection device according to any of the claims 1 to 7, the method comprising the steps of:

(i) Bringing the piston rod means (50, 150) in abutment with the plunger (44, 144)

(ii) Securing the piston rod means (50, 150) in this position.

15. A method of assembling an injection device according to claim 14, characterized in that, the piston rod means (50, 150) comprises a piston rod (160) and a piston rod foot (170).

5

16. A method of assembling an injection device according to claim 15, characterized in that, the axial distance between the piston rod (160) and the piston rod foot (170) is variable during assembly.

10

17. A method of assembling an injection device according to claim 16, characterized in that, the piston rod foot (170) is locked to the piston rod (160) during assembly.

18. A method of assembling an injection device according to claim 14, characterized in that, the piston rod means (50, 150) is telescopic during assembly.

15

19. A method of assembling an injection device according to claim 18, characterized in that, the parts making up the telescopic piston rod is locked together during assembly.

20. A system comprising an injection device with a dose setting and injection mechanism

20

having piston rod means (50, 150) and a container (40, 140) with a movable plunger (44, 144) and which system further comprises means for varying the distance between the piston rod means (50, 150) and the movable plunger (44, 144).

21. A system according to claim 23 characterized in that, the means for varying the distance

25

22. A system according to claim 23, characterized in that, the means for varying the distance comprises a first housing part (20) and a second housing part (30).

30

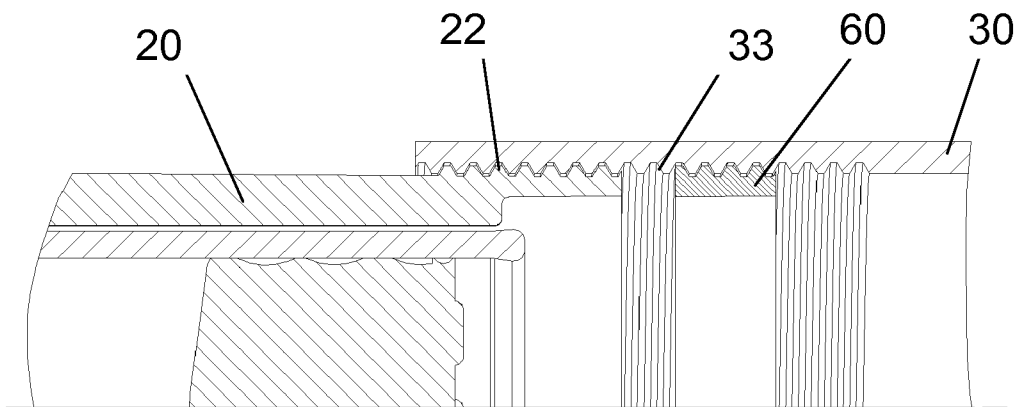
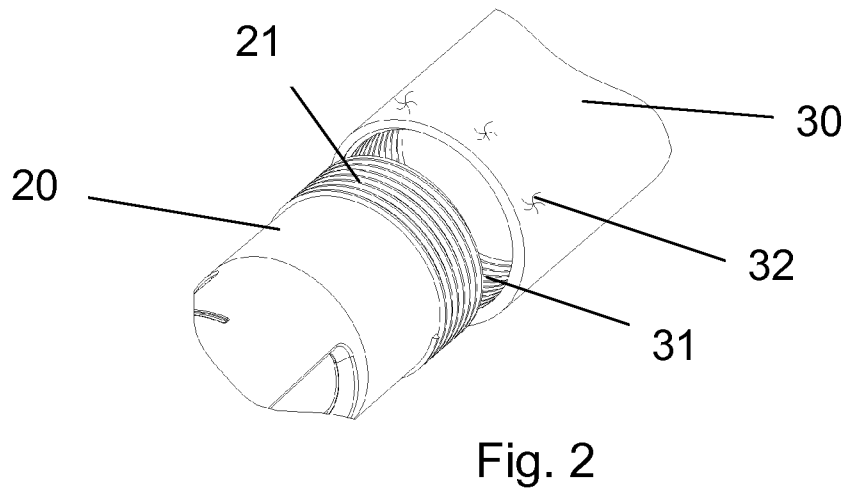
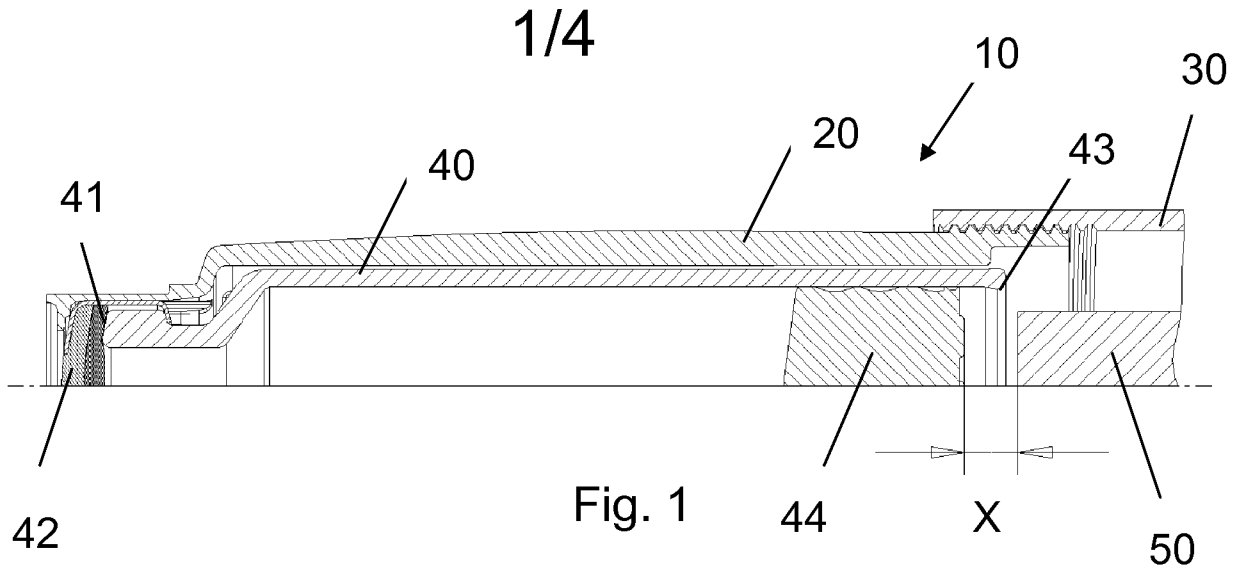

2/4

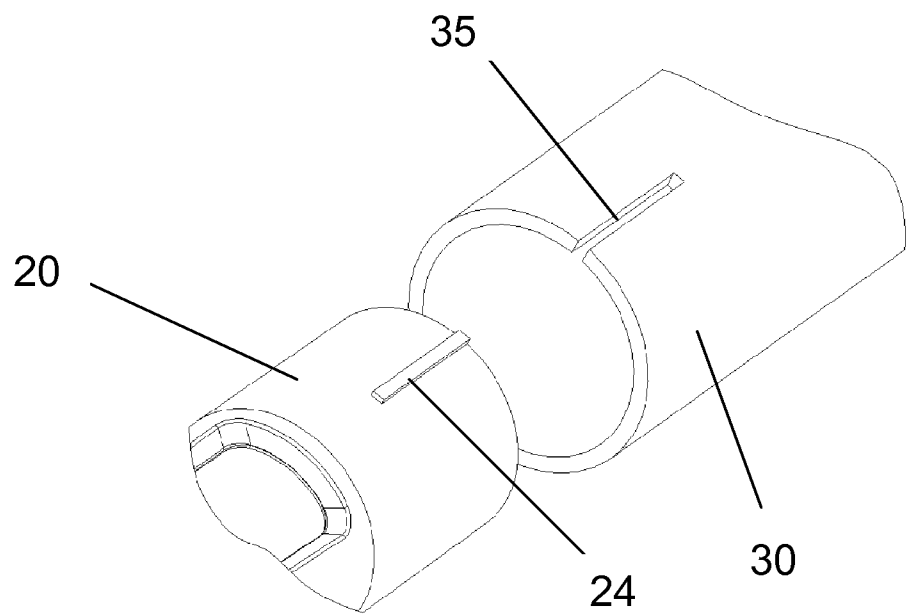
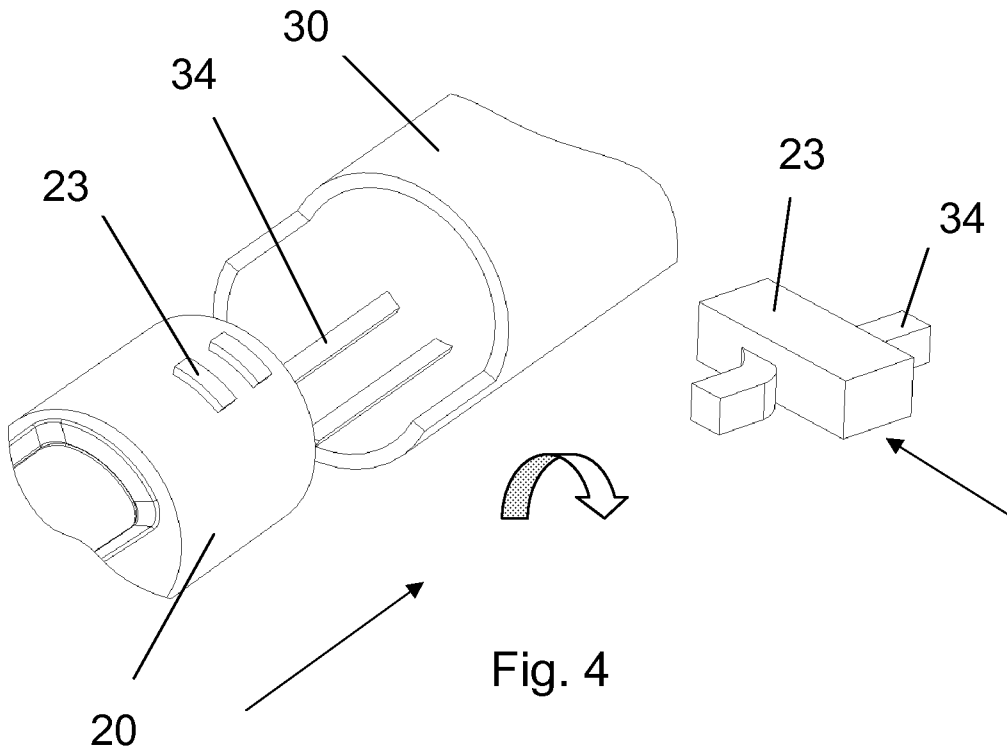

3/4

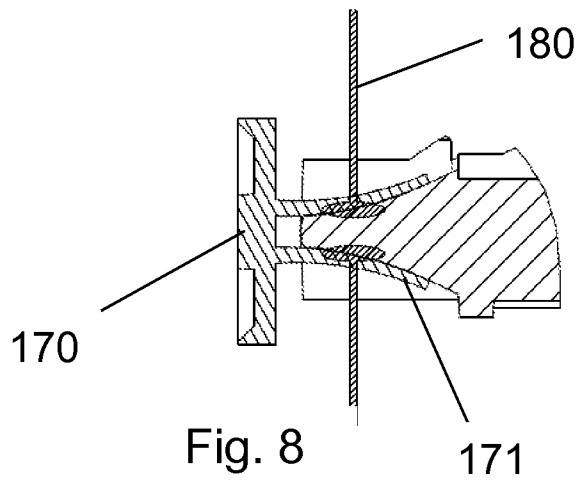
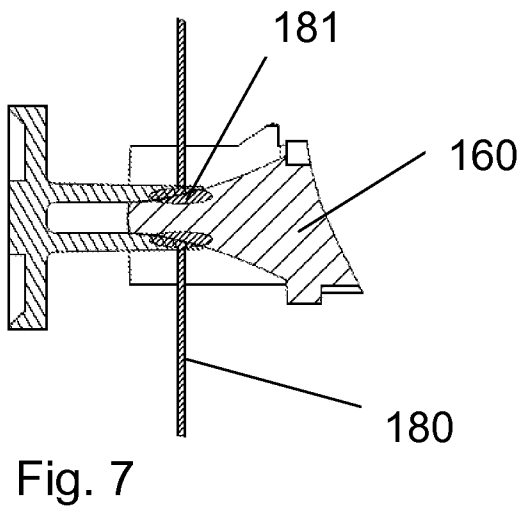
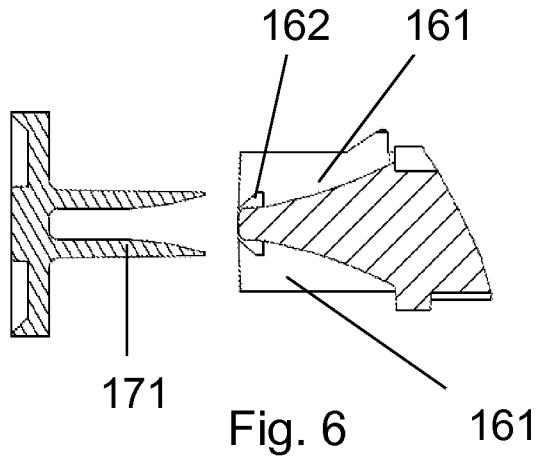

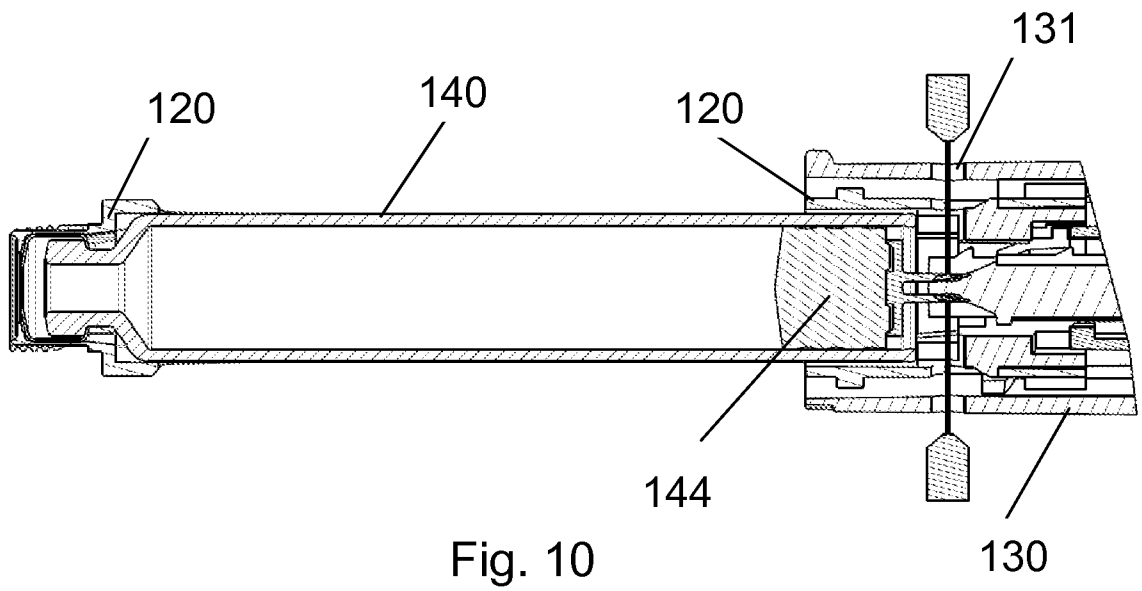
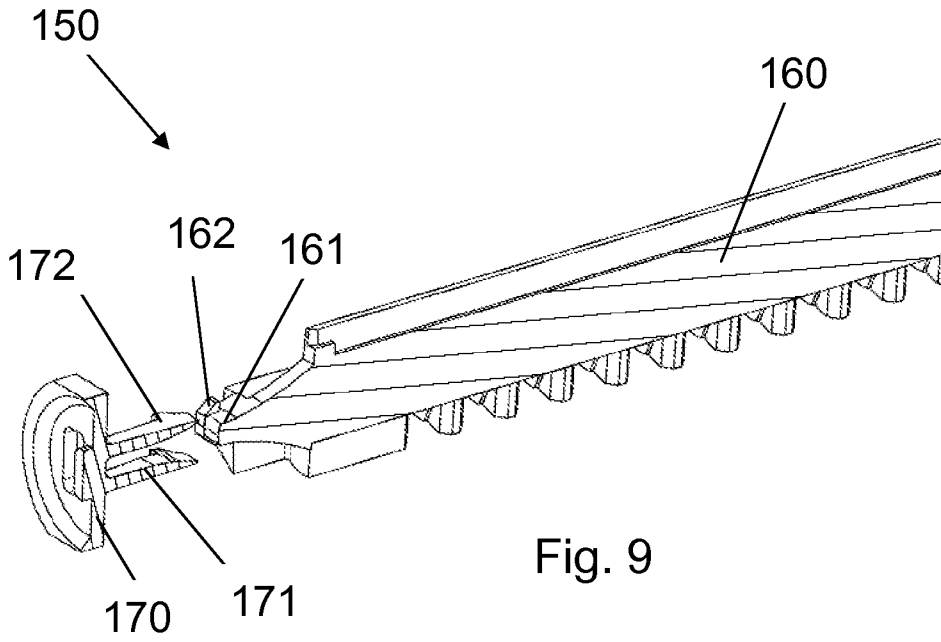

INTERNATIONAL SEARCH REPORT

International application No

PCT/EP2009/050590

A. CLASSIFICATION OF SUBJECT MATTER

INV. A61M5/315 A61M5/24 A61M5/31

According to International Patent Classification (IPC) or to both national classification and IPC

B. FIELDS SEARCHED

Minimum documentation searched (classification system followed by classification symbols)

A61M

Documentation searched other than minimum documentation to the extent that such documents are included in the fields searched

Electronic data base consulted during the international search (name of data base and, where practical, search terms used)

EPO-Internal

C. DOCUMENTS CONSIDERED TO BE RELEVANT

Category*	Citation of document, with indication, where appropriate, of the relevant passages	Relevant to claim No.
X	GB 806 703 A (COOK WAITE LAB INC) 31 December 1958 (1958-12-31) page 1, line 89 - page 3, line 4 figures 1,2,5	1-6, 13-16
X	WO 97/10864 A (BECTON DICKINSON CO [US]) 27 March 1997 (1997-03-27) page 9, line 8 - line 9 page 11, line 5 - page 12, line 1 figures 2,3	1-3,8, 12,20-22
A		13
X	EP 1 074 273 A (BECTON DICKINSON CO [US]) 7 February 2001 (2001-02-07) column 4, line 31 - line 39 figures 1a,2a	1
	----- -/--	

 Further documents are listed in the continuation of Box C. See patent family annex.

* Special categories of cited documents:

- *A* document defining the general state of the art which is not considered to be of particular relevance
- *E* earlier document but published on or after the international filing date
- *L* document which may throw doubts on priority claim(s) or which is cited to establish the publication date of another citation or other special reason (as specified)
- *O* document referring to an oral disclosure, use, exhibition or other means
- *P* document published prior to the international filing date but later than the priority date claimed

- *T* later document published after the international filing date or priority date and not in conflict with the application but cited to understand the principle or theory underlying the invention
- *X* document of particular relevance; the claimed invention cannot be considered novel or cannot be considered to involve an inventive step when the document is taken alone
- *Y* document of particular relevance; the claimed invention cannot be considered to involve an inventive step when the document is combined with one or more other such documents, such combination being obvious to a person skilled in the art.
- * & * document member of the same patent family

Date of the actual completion of the international search

28 May 2009

Date of mailing of the international search report

05/06/2009

Name and mailing address of the ISA/

European Patent Office, P.B. 5818 Patentlaan 2
NL - 2280 HV Rijswijk
Tel. (+31-70) 340-2040,
Fax: (+31-70) 340-3016

Authorized officer

Sedy, Radim

INTERNATIONAL SEARCH REPORT

International application No
PCT/EP2009/050590

C(Continuation). DOCUMENTS CONSIDERED TO BE RELEVANT		
Category*	Citation of document, with indication, where appropriate, of the relevant passages	Relevant to claim No.
A	US 2004/215153 A1 (GRAF RONEY [CH] ET AL) 28 October 2004 (2004-10-28) figure 4 -----	4

INTERNATIONAL SEARCH REPORT

Information on patent family members

International application No

PCT/EP2009/050590

Patent document cited in search report		Publication date	Patent family member(s)	Publication date
GB 806703	A	31-12-1958	NONE	
WO 9710864	A	27-03-1997	AT 240757 T CA 2231868 A1 DE 69628322 D1 DE 69628322 T2 EP 0862473 A1 ES 2199296 T3 JP 3824649 B2 JP 11511364 T US 5688251 A	15-06-2003 27-03-1997 26-06-2003 19-02-2004 09-09-1998 16-02-2004 20-09-2006 05-10-1999 18-11-1997
EP 1074273	A	07-02-2001	CA 2314940 A1 DE 60014279 D1 DE 60014279 T2 ES 2223351 T3 JP 4252199 B2 JP 2001087386 A US 6277099 B1	06-02-2001 04-11-2004 02-06-2005 01-03-2005 08-04-2009 03-04-2001 21-08-2001
US 2004215153	A1	28-10-2004	AT 357268 T BR 0211552 A CA 2451872 A1 WO 03011370 A2 CN 1541122 A EP 1416982 A2 HR 20040093 A2 JP 4011543 B2 JP 2004535900 T JP 2007260421 A MX PA04000866 A	15-04-2007 26-10-2004 13-02-2003 13-02-2003 27-10-2004 12-05-2004 28-02-2005 21-11-2007 02-12-2004 11-10-2007 06-06-2005