



(19) **United States**

(12) **Patent Application Publication**
McClurg et al.

(10) **Pub. No.: US 2004/0109245 A1**

(43) **Pub. Date: Jun. 10, 2004**

(54) **NON-PLANAR PRISM IN A SYSTEM FOR OBTAINING PRINT AND OTHER HAND CHARACTERISTIC INFORMATION**

Publication Classification

(51) **Int. Cl.⁷ G02B 5/04**
(52) **U.S. Cl. 359/833**

(75) **Inventors: George W. McClurg, Jensen Beach, FL (US); John F. Carver, Palm City, FL (US); Frank L. Ebright, Hobe Sound, FL (US)**

(57) **ABSTRACT**

A system and method are provided for scanning all or part of a hand print for one or more hands positioned on a non-planar portion of a prism. The non-planar portion can be symmetrical about an axis of symmetry of the prism. Typically, a palm pocket, writer's palm, or the like, is hard to capture on a flat surface. In contrast, the non-planar portion of the prism according to embodiments of the present invention provides a form so that the palm pocket, writer's palm, or the like, can be captured. Hand and/or finger characteristic data can also be captured, for example hand geometry (e.g., finger lengths and spacing between fingers). The prism can also include a positioning device (e.g., a hand-locating feature) than can be used to position a hand based on a point between a thumb and an index finger, between any other two fingers, a full hand on one side of the alignment device, both hands with each hand on either side of the alignment device, or to capture writer's palm and/or writer's palm and fingertip images.

Correspondence Address:
STERNE, KESSLER, GOLDSTEIN & FOX PLLC
1100 NEW YORK AVENUE, N.W.
WASHINGTON, DC 20005 (US)

(73) **Assignee: Cross Match Technologies, Inc.**

(21) **Appl. No.: 10/725,539**

(22) **Filed: Dec. 3, 2003**

Related U.S. Application Data

(60) **Provisional application No. 60/431,240, filed on Dec. 6, 2002. Provisional application No. 60/491,537, filed on Aug. 1, 2003.**

100 ↘

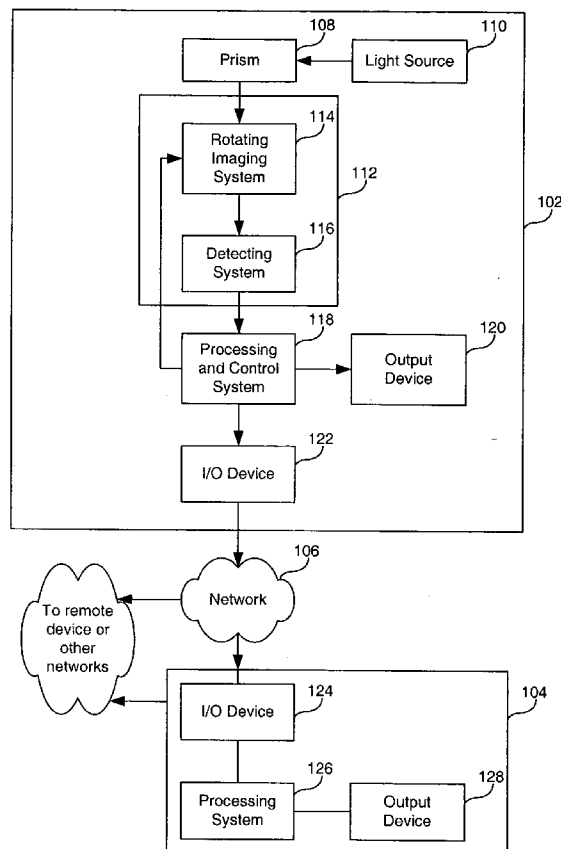

100 ↘

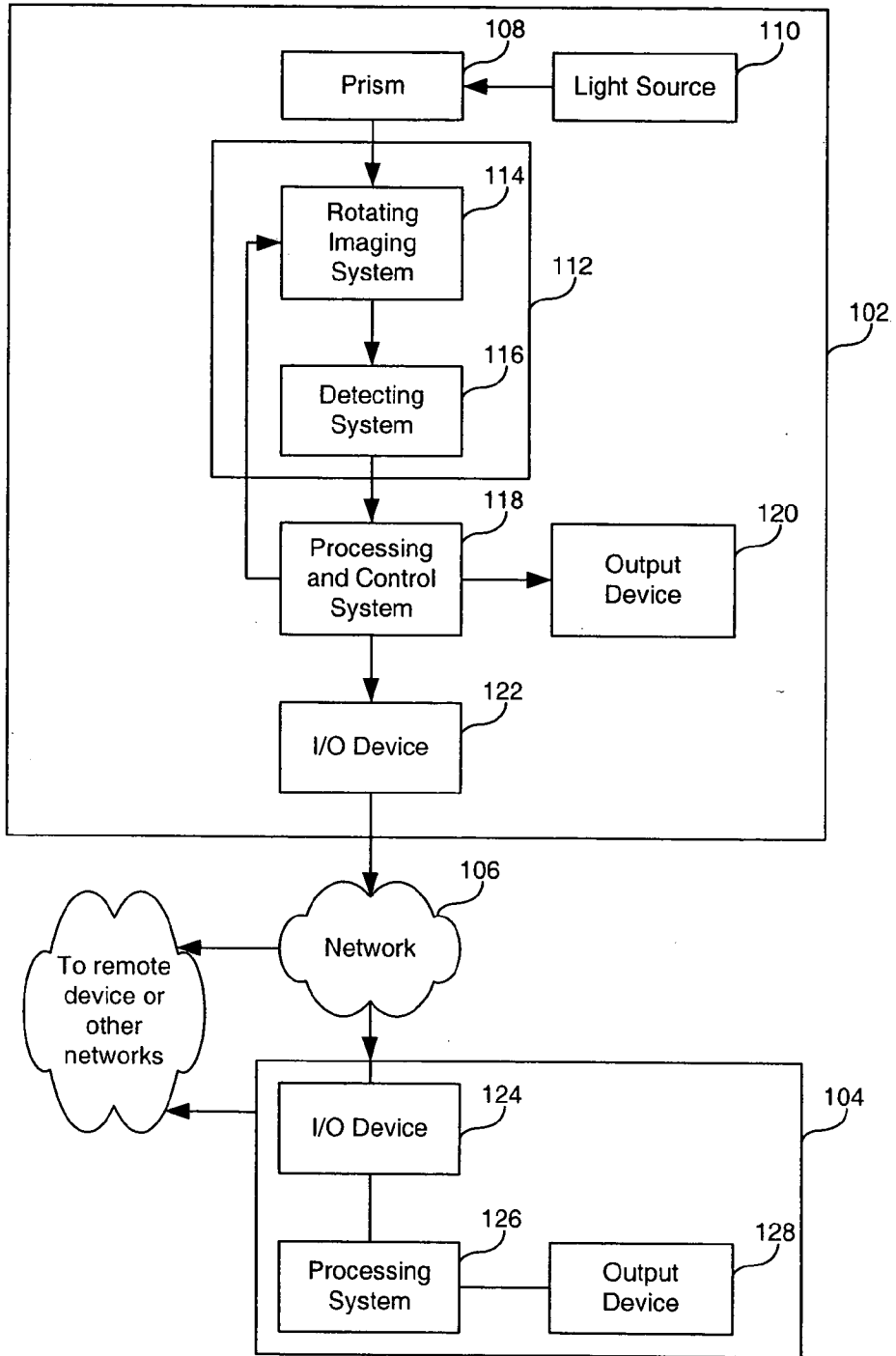

FIG. 1

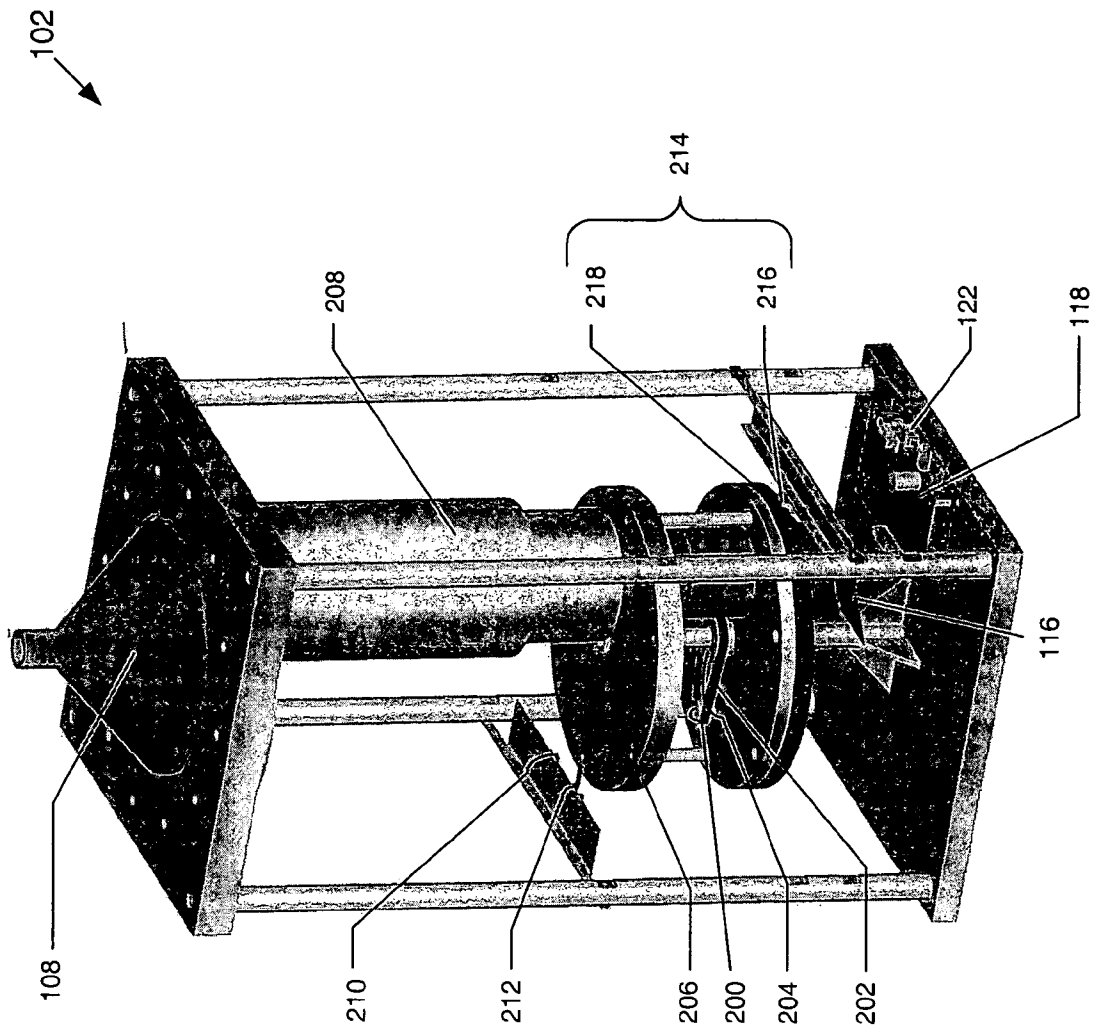

FIG. 2

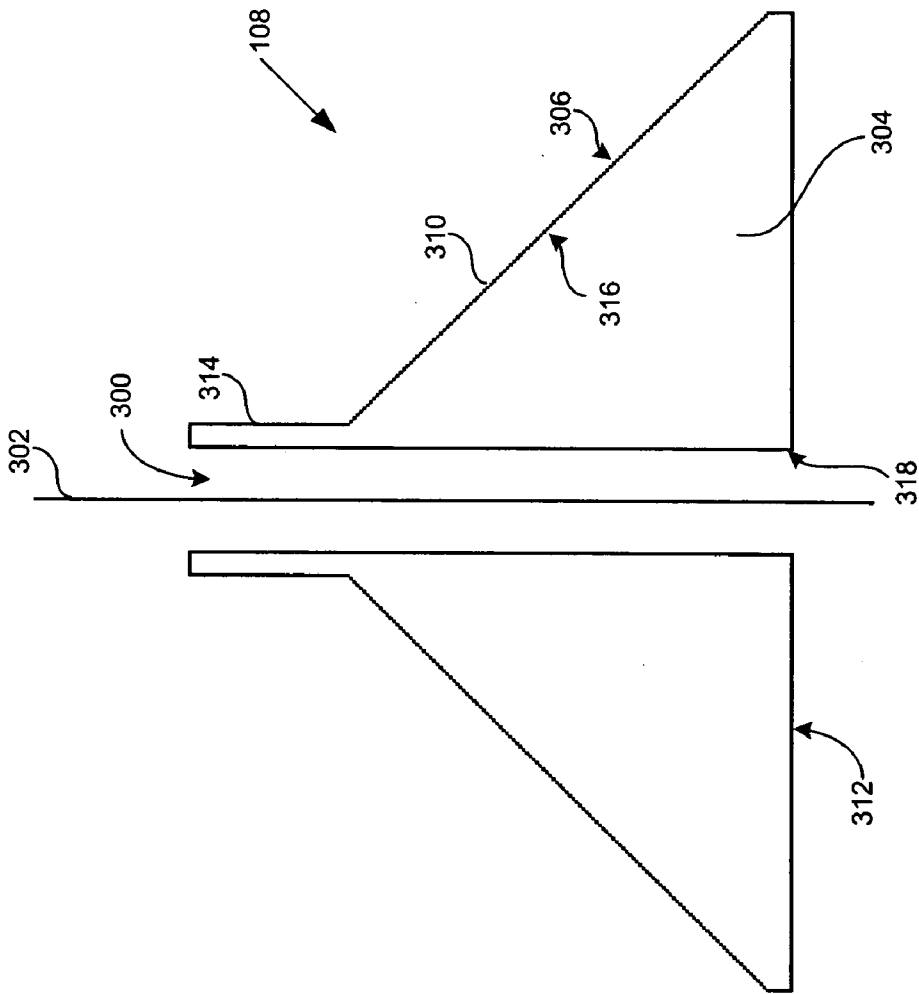

FIG. 3

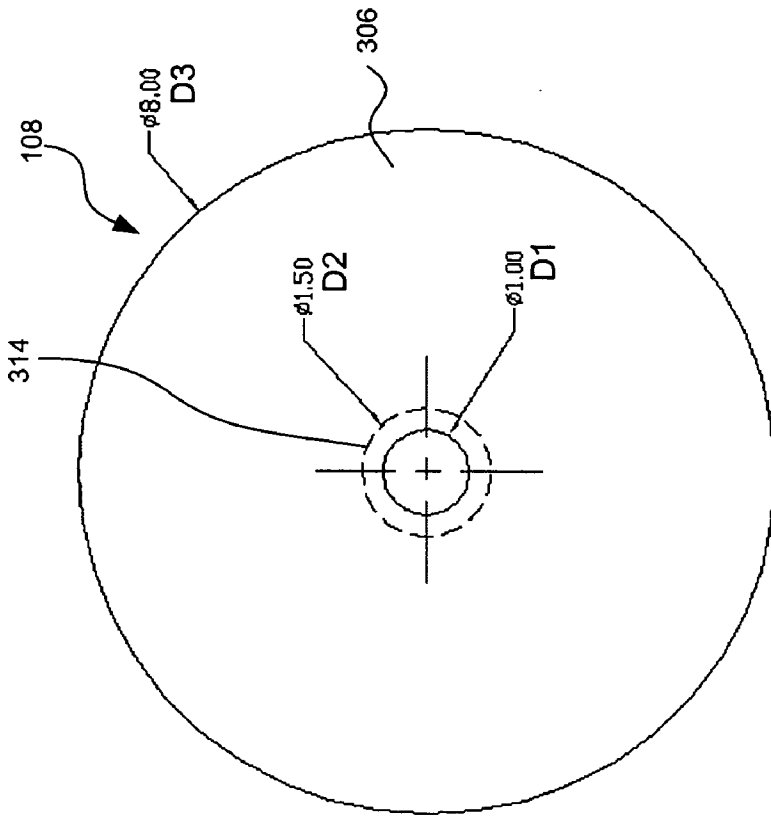

FIG. 5

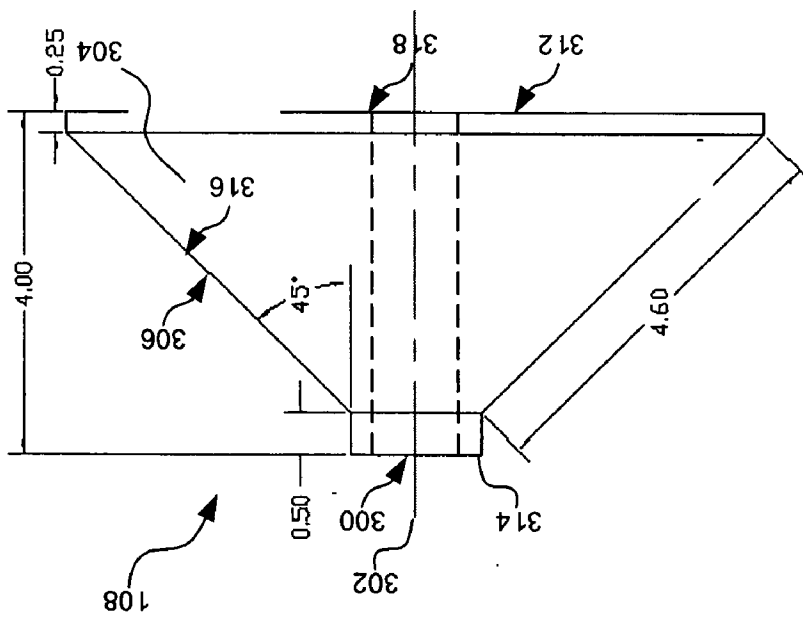

FIG. 4

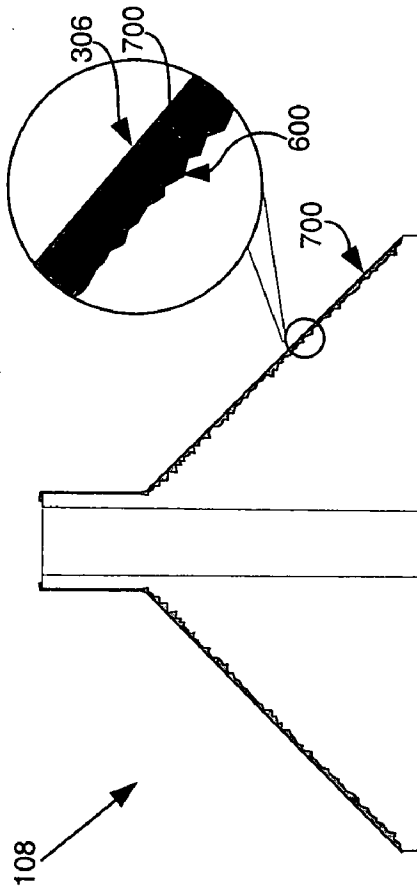

FIG. 6

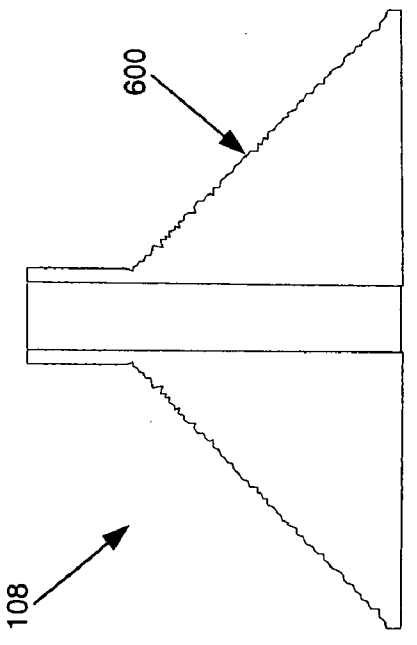

FIG. 7

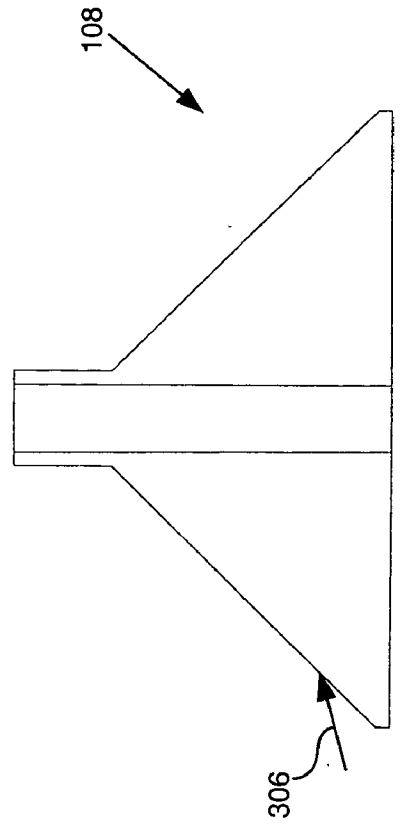

FIG. 8

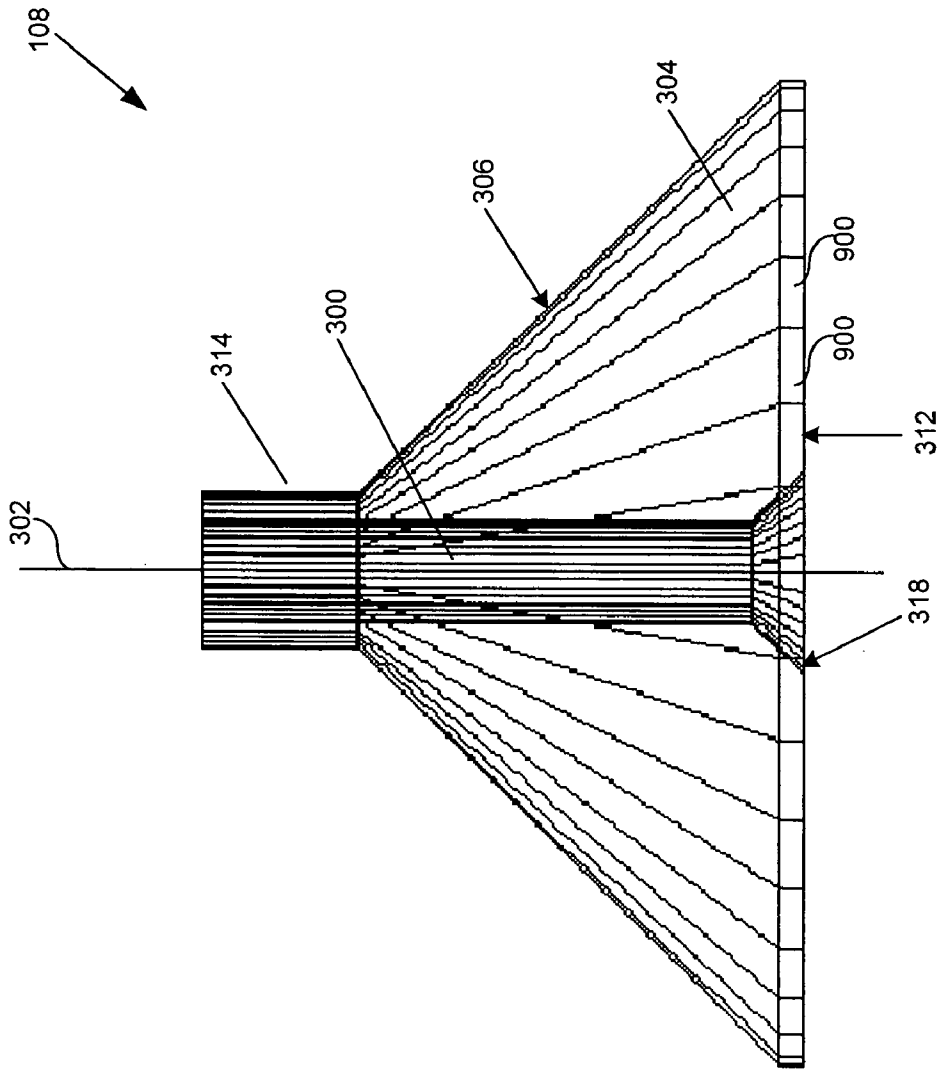

FIG. 9

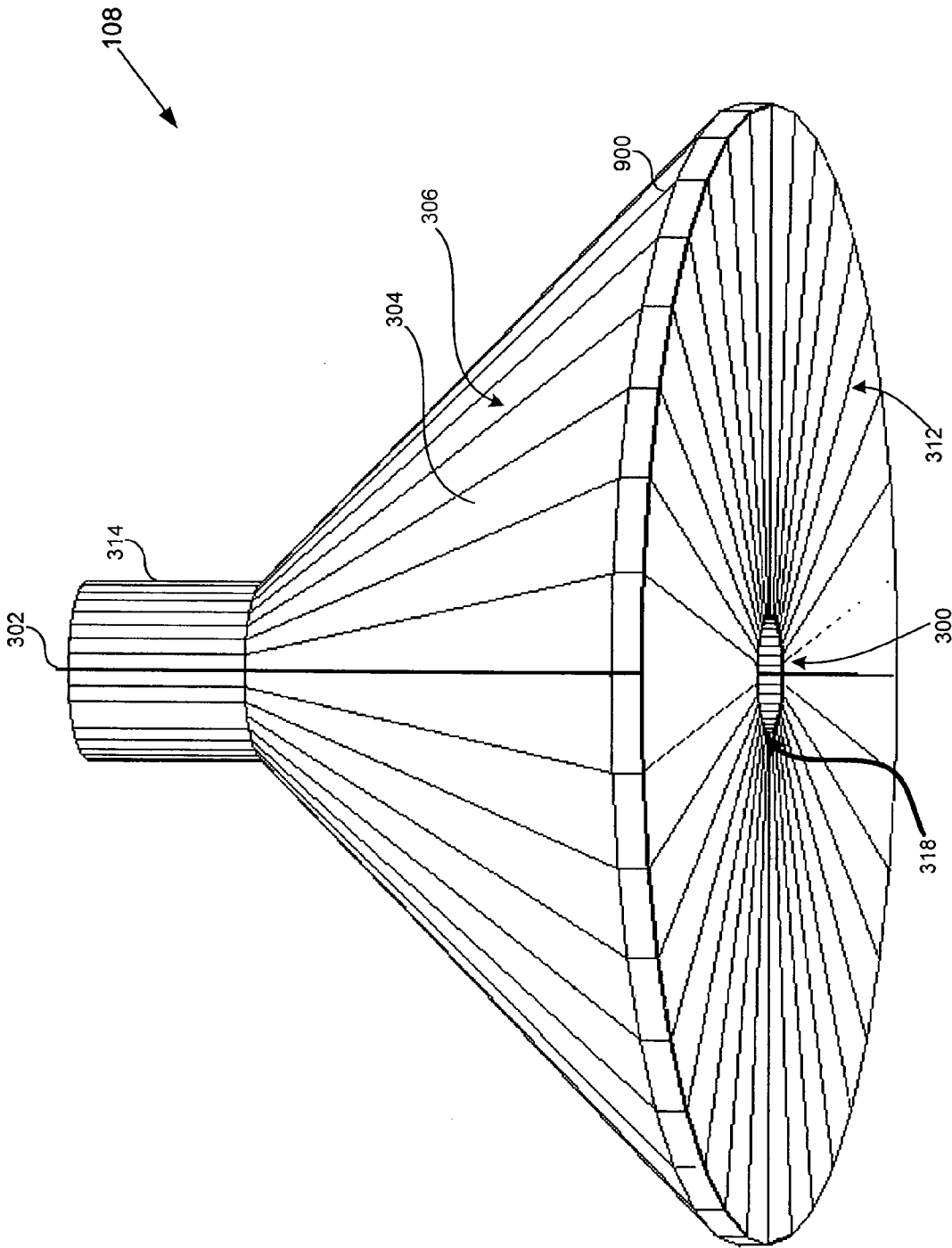

FIG. 10

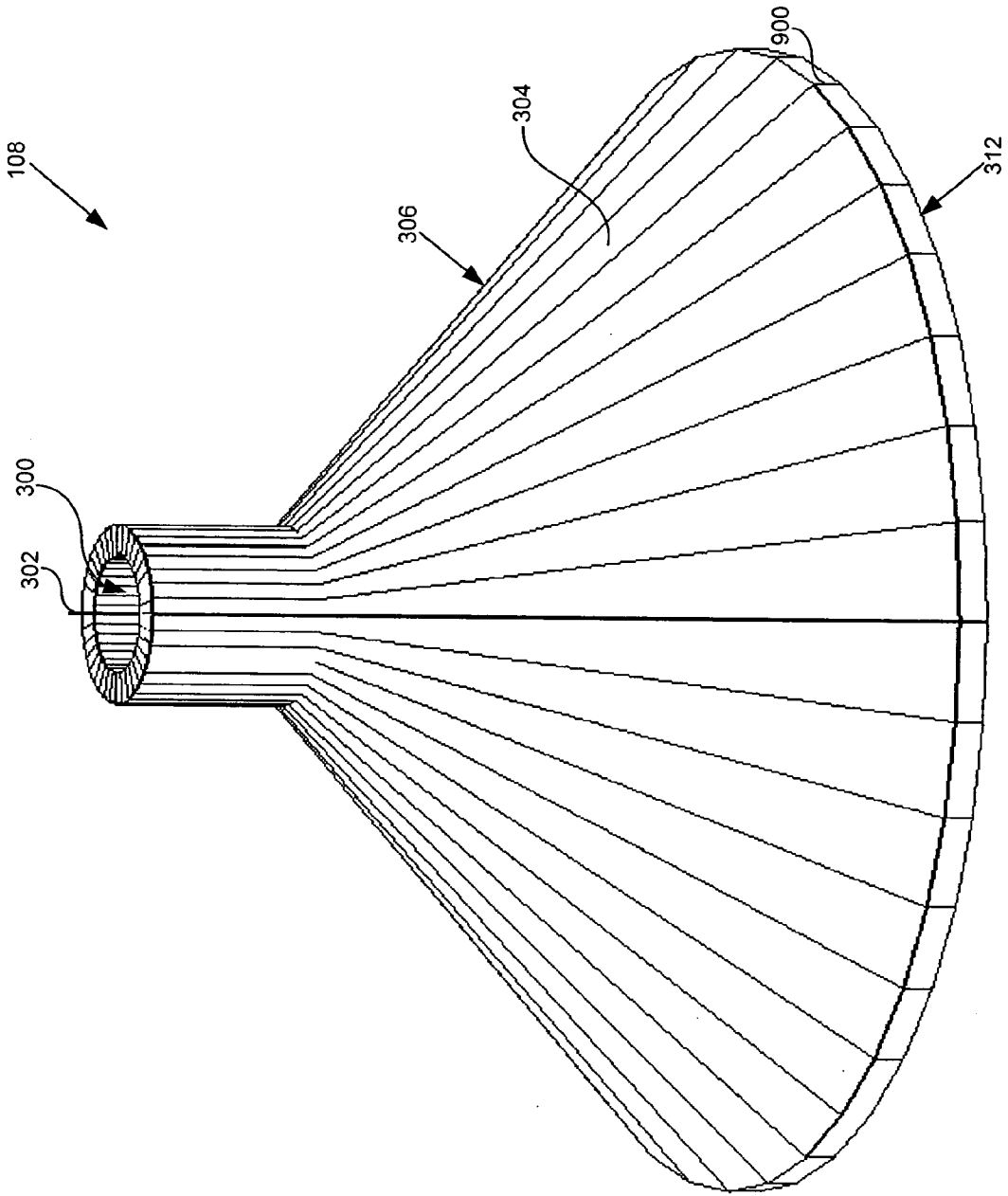

FIG. 11

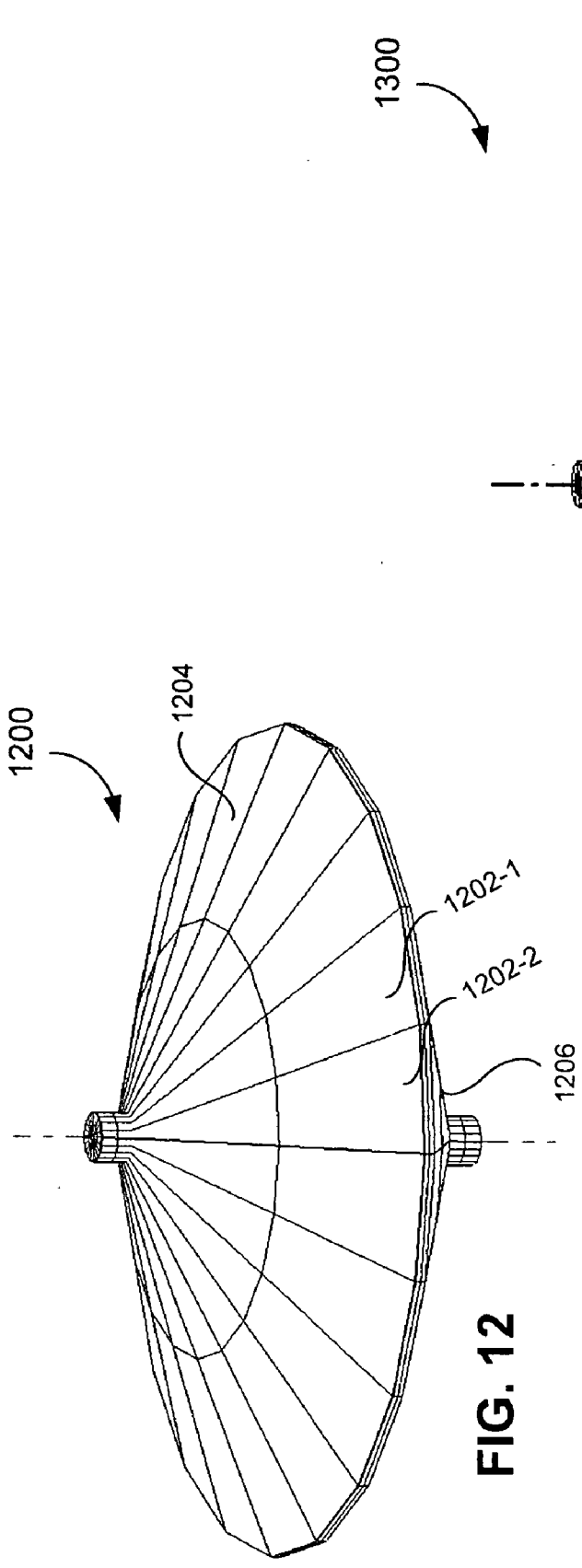

FIG. 12

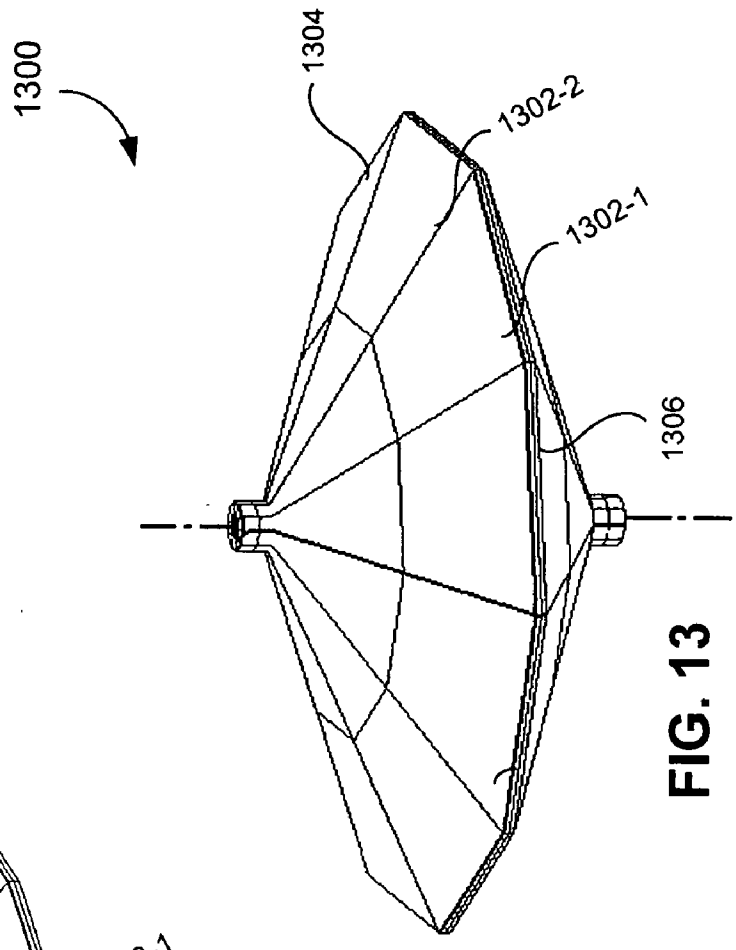

FIG. 13

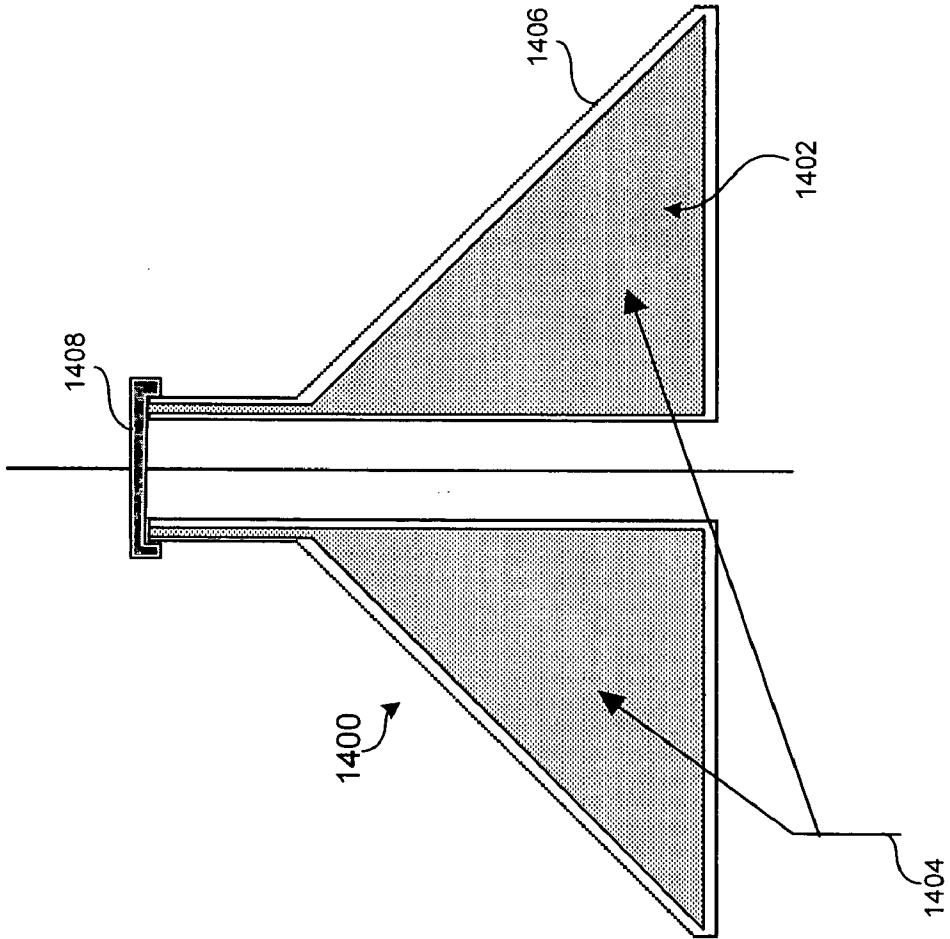

FIG. 14

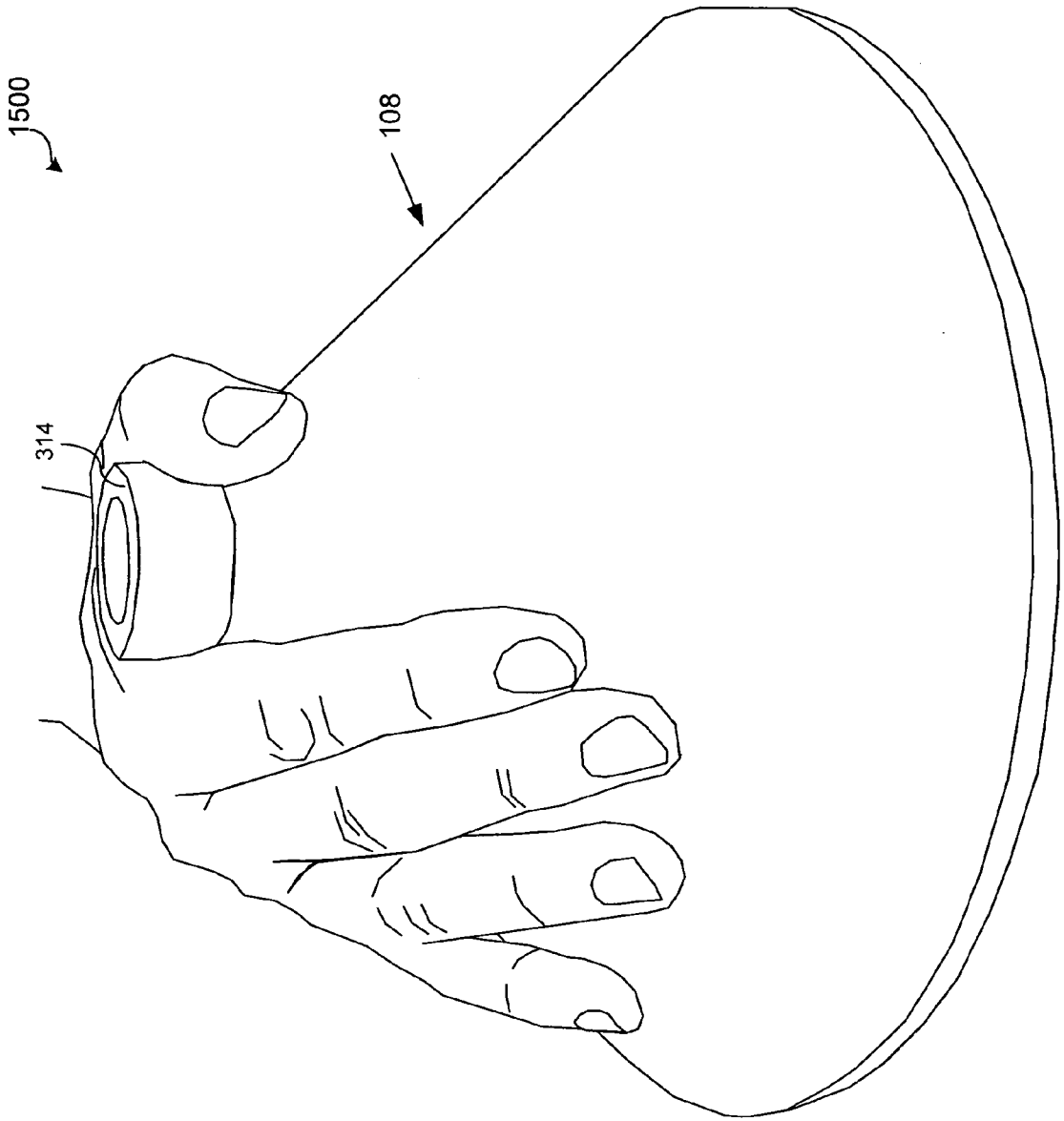

FIG. 15

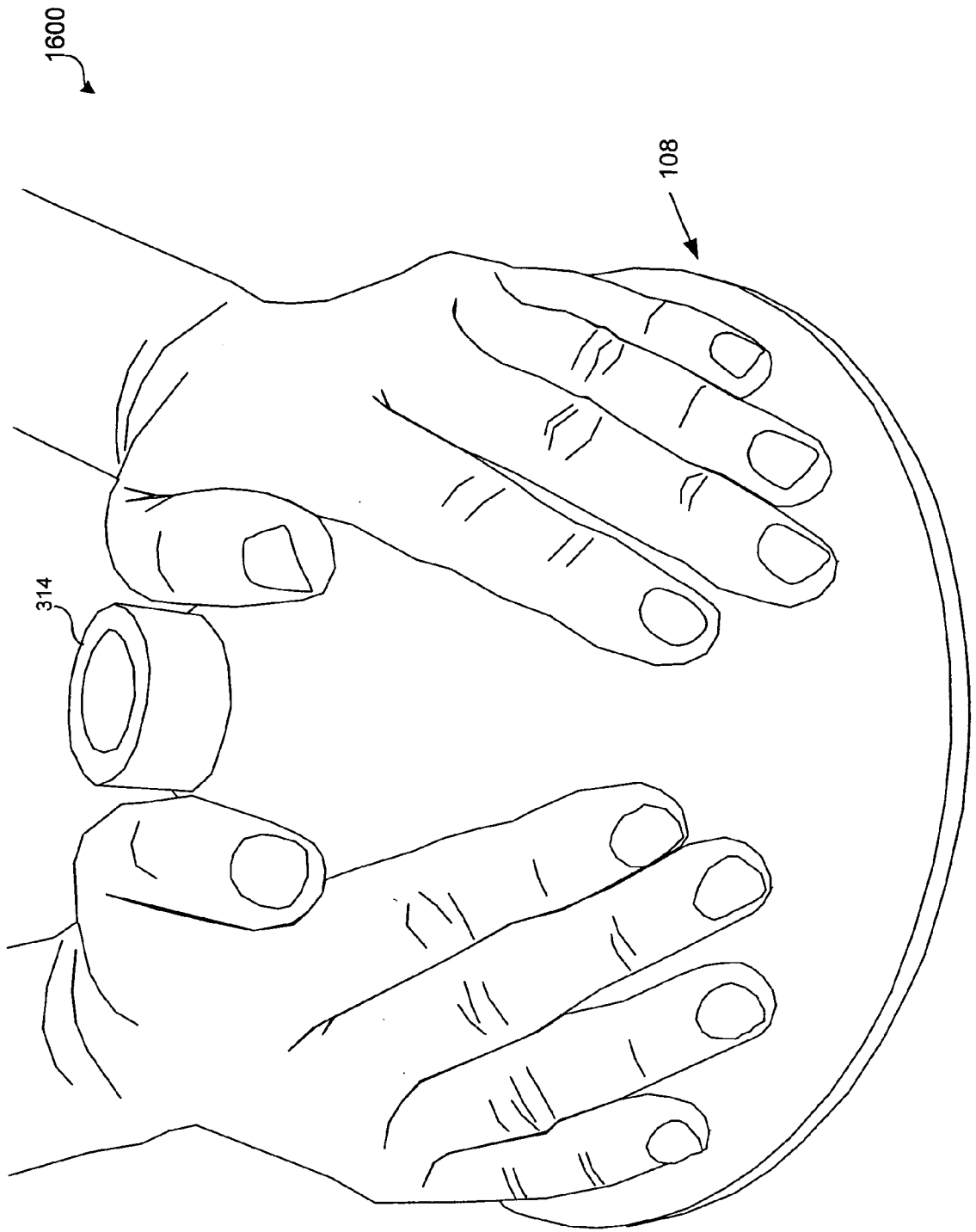

FIG. 16

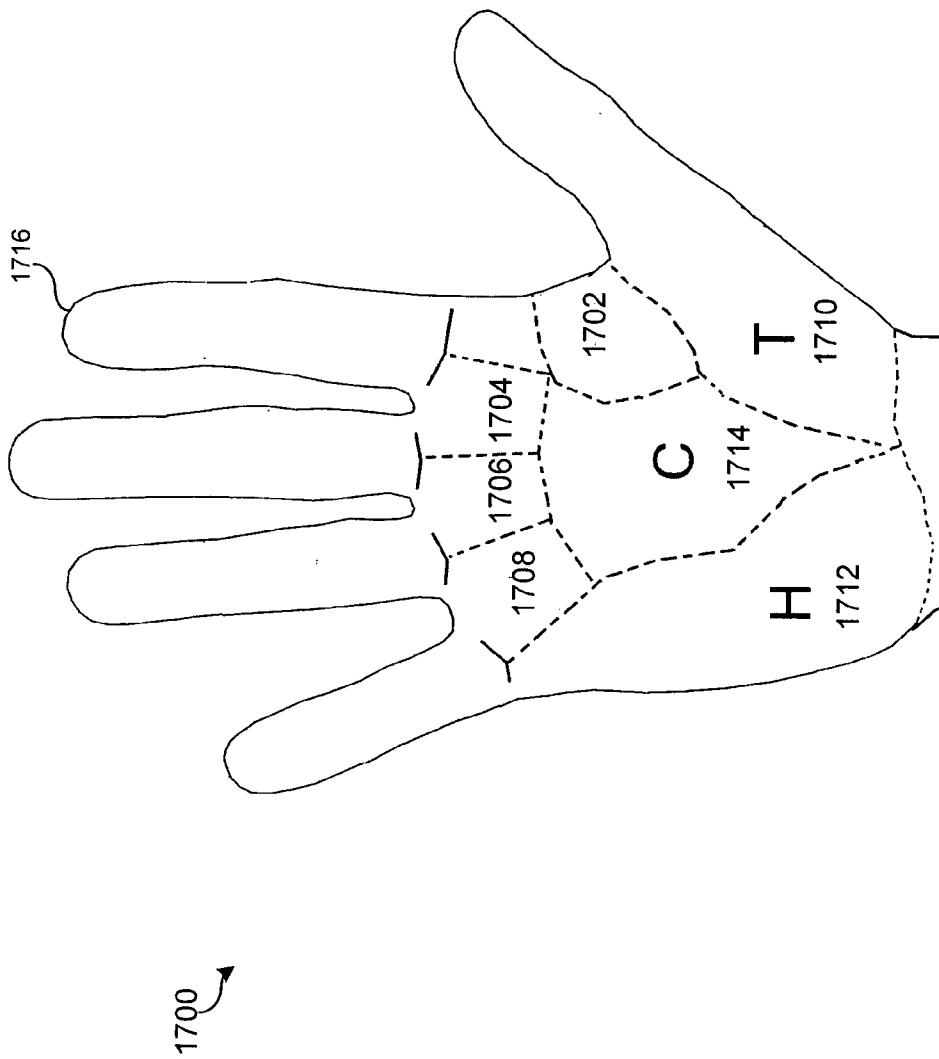

FIG. 17

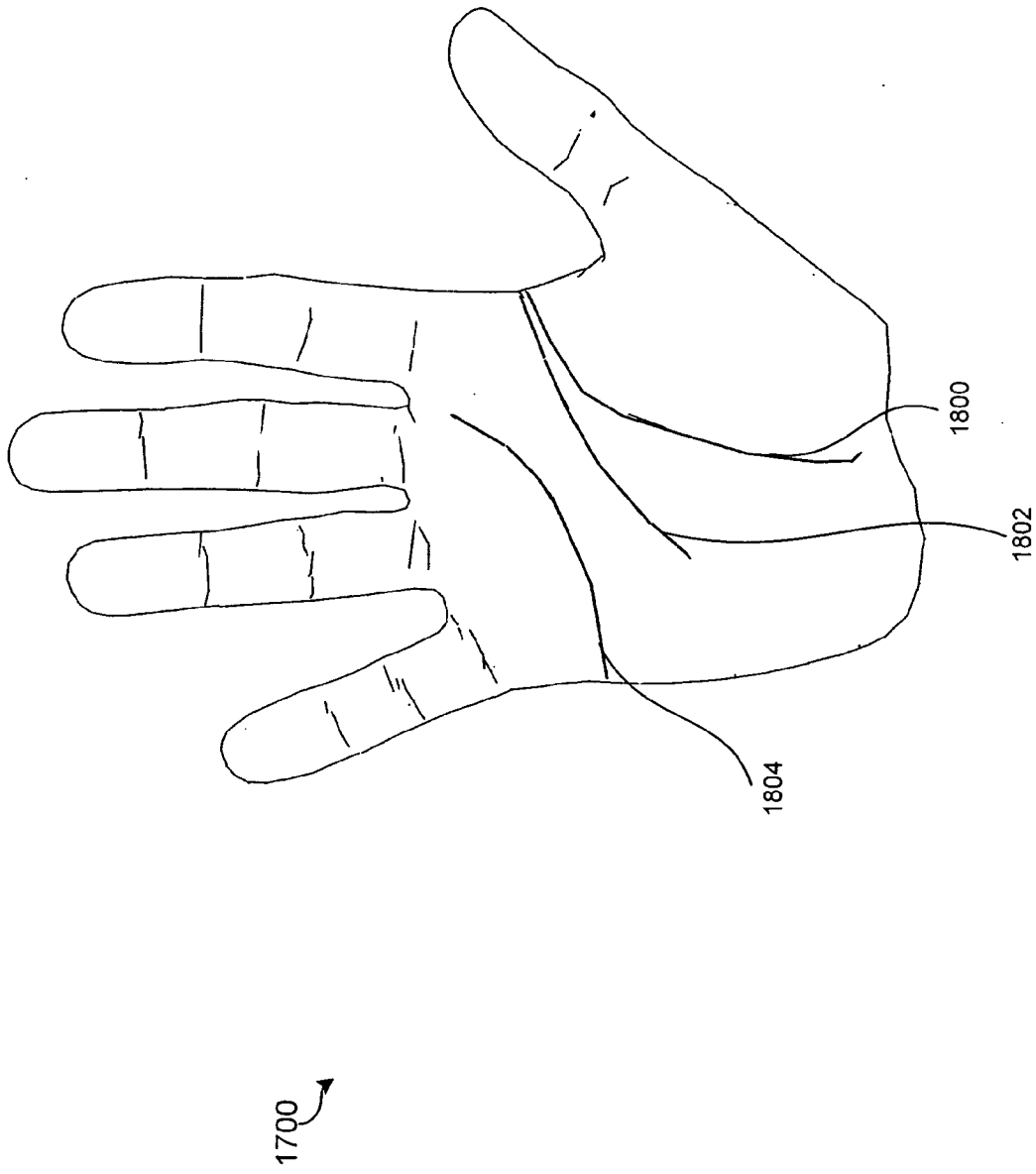

FIG. 18

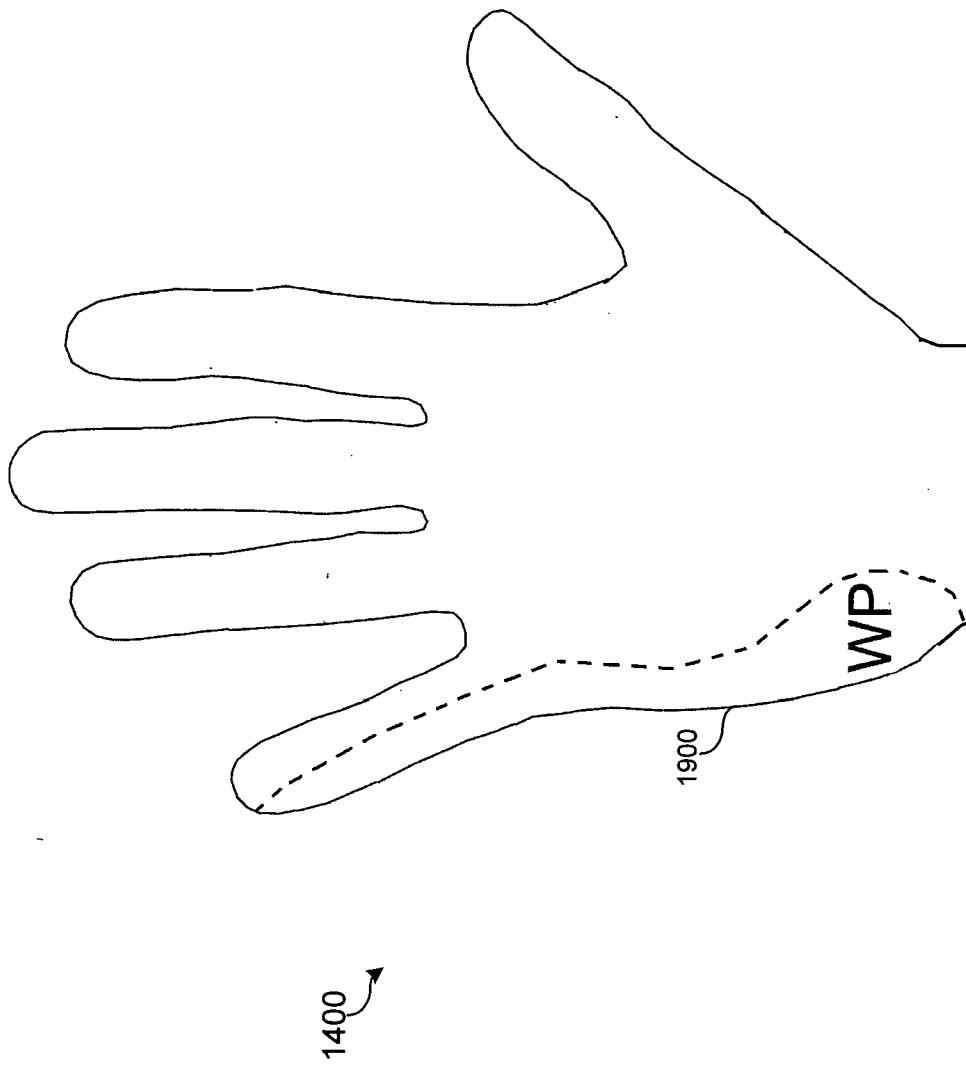

FIG. 19



FIG. 20



FIG. 21

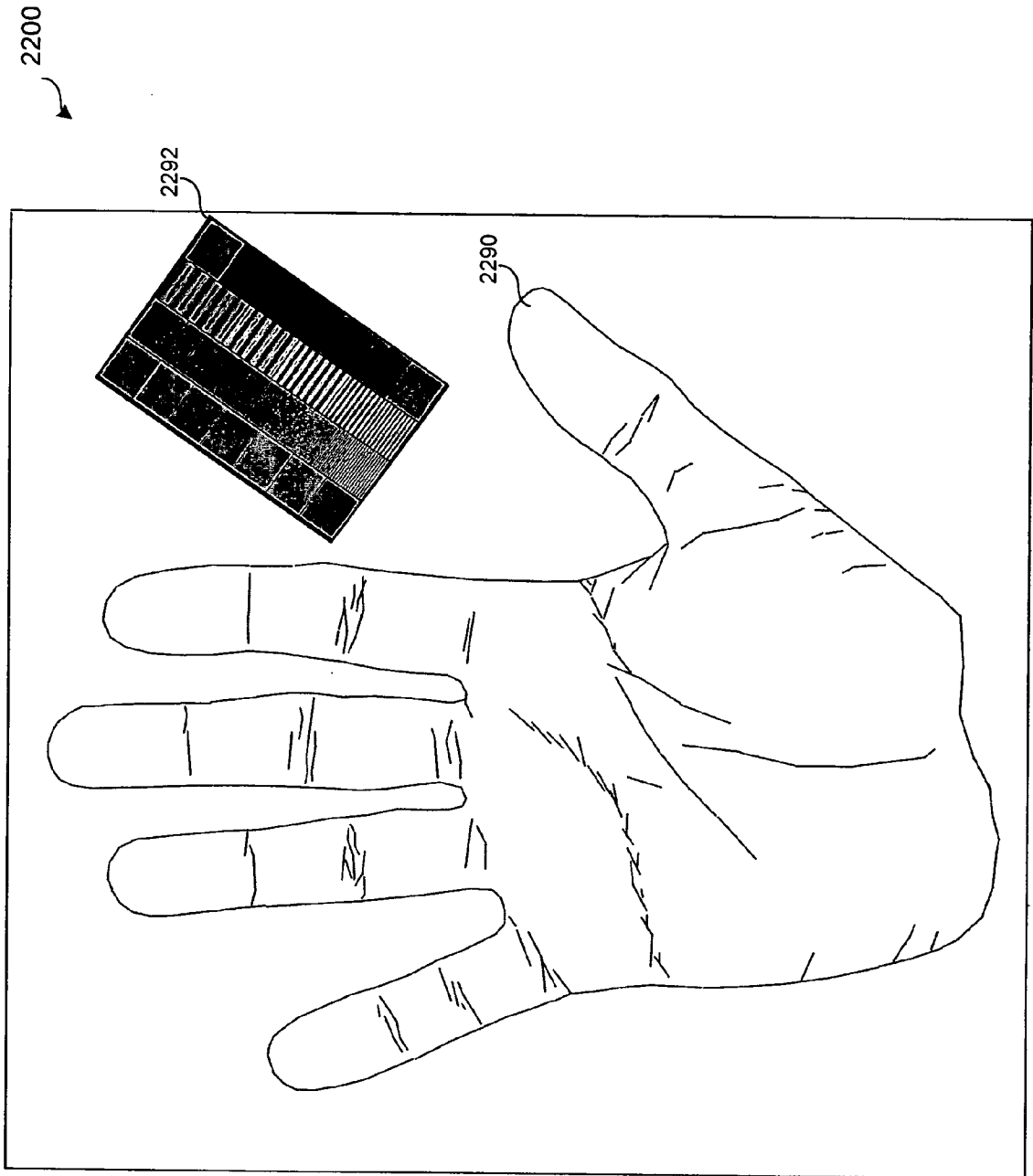

FIG. 22

NON-PLANAR PRISM IN A SYSTEM FOR OBTAINING PRINT AND OTHER HAND CHARACTERISTIC INFORMATION

CROSS REFERENCE TO RELATED APPLICATIONS

[0001] This application claims the benefit of U.S. Provisional Application No. 60/431,240, filed Dec. 6, 2002, and U.S. Provisional Application No. 60/491,537, filed Aug. 1, 2003, both of which are incorporated herein by reference in their entireties.

BACKGROUND OF THE INVENTION

[0002] 1. Field of the Invention

[0003] The present invention pertains to biometric imaging technology, and in particular, to live scanning of prints.

[0004] 2. Background Art

[0005] Biometrics is a science involving the analysis of biological characteristics. Biometric imaging captures a measurable characteristic of a human being for identity and other related purposes. Print capture and recognition is an important biometric technology. Law enforcement, banking, voting, and other industries increasingly rely upon prints as a biometric to store, recognize or verify identity. Generally, a biometric is a measurable, physical characteristic or personal behavior trait used to recognize the identity, or verify the claimed identity, of a person who has a biometric reference template (e.g., data that represents a biometric measurement) on file.

[0006] Biometric imaging systems may include, but are not limited to, print imaging systems. Print imaging systems can capture images of prints on thumbs, fingers, palms, toes, feet, and/or hands. Such print imaging systems are also referred to as scanners or live scanners. Conventional live scanners use light to detect an image of a fingerprint and/or palm print. For example, one or more fingers or a palm are placed on a platen. An illumination source illuminates the underside of the platen. An image representative of valleys, ridges, or other characteristics of a fingerprint or a palm print is then detected by an image sensor, such as a solid-state camera.

[0007] One problem with conventional palm live scanner systems is that a palm naturally curves, while a typical platen has a flat planar surface upon which a palm is placed. Thus, there is a chance that not all portions of the palm print will be imaged during scanning. If this occurs, biometric information can be lost.

[0008] Also, in many live scanners, increasing the surface area of a flat platen requires a significant increase in the size of a camera being used to detect images on the platen. Large area cameras or sets of cameras can dramatically increase cost and complexity. As a result, the size of the surface area of a flat platen is limited in many live scanners to a size of an average palm or smaller.

[0009] Therefore, what is needed is a biometric capture system that includes an optical device shaped to better conform to a palm of a user's hand.

BRIEF SUMMARY OF THE INVENTION

[0010] Embodiments of the present invention provide a prism used in a system configured to capture image data

representative of biometric data. The prism includes a non-planar first portion that is symmetrical about an axis of symmetry of the prism and is configured to receive a portion of a body of a user, a substantially planar second portion coupled an angle with respect to the non-planar first portion, and a cylindrical opening running from the first portion to the second portion along the axis of symmetry.

[0011] Other embodiments of the present invention provide a prism configured to be used in a system for capturing image data representative of biometric data. The prism includes an input portion, a non-planar platen portion, and an exit portion. The input portion is configured to receive light from a light source. The non-planar platen portion is symmetrical about an axis of symmetry of the prism and is configured to receive a portion of a body of a user on a first surface and to totally internally reflect the light from the light source off a second surface. The exit portion is configured to pass the light that has been totally internally reflected from the second surface of the platen portion onto a detector, which is configured to perform the capturing of the image data.

[0012] Still further embodiments of the present invention provide a prism configured to be used in a system for capturing image data representative of biometric data. The prism includes non-planar first and second portions. The first portion is symmetrical about an axis of symmetry of the prism and is configured to receive a portion of a body of a user on a first surface and to totally internally reflect illumination from a second surface. The second portion is also symmetrical about the axis of symmetry of the prism and is coupled to the first portion. The second portion is configured to pass light that has been totally internally reflected from the second surface of the first portion onto a detector that is configured to perform the capturing of the image data.

[0013] One advantage of the above embodiments can be that all aspects of print (e.g., a whole hand print or a two-hand print, a palm print, a writer's palm print, a writer's palm print in combination with fingertips, etc.) associated with one or more hands of a user can be captured based on the non-planar first portion.

[0014] Further embodiments, features, and advantages of the present inventions, as well as the structure and operation of the various embodiments of the present invention, are described in detail below with reference to the accompanying drawings.

BRIEF DESCRIPTION OF THE DRAWINGS/FIGURES

[0015] The accompanying drawings, which are incorporated herein and form a part of the specification, illustrate the present invention and, together with the description, further serve to explain the principles of the invention and to enable a person skilled in the pertinent art to make and use the invention.

[0016] FIG. 1 shows a system for capturing biometric data according to an embodiment of the present invention.

[0017] FIG. 2 shows a local section of the system in FIG. 1 according to an embodiment of the present invention.

[0018] FIGS. 3-8 show various views of a prism according to an embodiment of the present invention.

[0019] FIGS. 9-11 show various views of image sectional areas on a prism according to various embodiments of the present invention.

[0020] FIGS. 12-13 show various prisms according to embodiments of the present invention.

[0021] FIG. 14 shows a material filled prism according to an embodiment of the present invention.

[0022] FIGS. 15-16 illustrate how a subject places one or both hands, respectively, on a prism according to various embodiments of the present invention.

[0023] FIGS. 17-19 show various parts of a hand used during image and biometric analysis according to embodiments of the present invention.

[0024] FIG. 20 shows an image of a print pattern of writer's palms and fingertips captured according to an embodiment of the present invention.

[0025] FIG. 21 show an image of a print pattern of left and right hand prints taken during different scans and captured according to an embodiment of the present invention.

[0026] FIG. 22 shows an exemplary image including hand print data and calibration data according to an embodiment of the present invention.

[0027] The present invention will now be described with reference to the accompanying drawings. In the drawings, like reference numbers can indicate identical or functionally similar elements. Additionally, the left-most digit(s) of a reference number may identify the drawing in which the reference number first appears.

DETAILED DESCRIPTION OF THE INVENTION

[0028] Embodiments of the present invention provide a system and method for scanning all or part of a hand print for one or more hands positioned on a non-planar portion of a prism. The non-planar portion can be symmetrical about an axis of symmetry of the prism. Typically, a palm pocket, writer's palm, or the like, is hard to capture on a flat surface. In contrast, the non-planar portion of the prism according to embodiments of the present invention provides a form so that the palm pocket, writer's palm, or the like, can be captured. Hand and/or finger characteristic data can also be captured, for example hand geometry (e.g., finger lengths and spacing between fingers).

[0029] The prism can also include a positioning device (e.g., a hand-locating feature) than can be used to position a hand based on a point between a thumb and an index finger, between any other two fingers, a full hand on one side of the alignment device, both hands with each hand on either side of the alignment device, or to capture writer's palm and/or writer's palm and fingertip images.

[0030] Terminology

[0031] To more clearly delineate the present invention, an effort is made throughout the specification to adhere to the following term definitions consistently.

[0032] The term "finger" refers to any digit on a hand including, but not limited to, a thumb, an index finger, middle finger, ring finger, or a pinky finger.

[0033] The term "print" can be any type of print including, but not limited to, a print of all or part of one or more fingers, palms, toes, foot, hand, etc. A print can also be a rolled print, a flat print, or a slap print.

[0034] The term "hand print," as used herein according to the present invention, can include any region on a hand having a print pattern, including the thenar and hypothenar regions of the palm, interdigital regions, palm heel, palm pocket, writer's palm, and/or fingertips.

[0035] The term "biometric data" or "biometric information" throughout the specification can be data representative of a biometric, a digital or other image of a biometric (e.g., raw image data, a bitmap, binary, or other file), extracted digital or other information relating to the biometric (such as minutiae), etc.

[0036] The term "live scan" refers to a capture of any type of print image made by a print scanner.

[0037] A platen can be movable or stationary depending upon the particular type of scanner and the type of print being captured by the scanner.

[0038] The terms "biometric imaging system," "scanner," "live scanner," "live print scanner," "fingerprint scanner," and "print scanner" are used interchangeably, and refer to any type of scanner which can obtain an image of a print pattern on all or part of one or more fingers, palms, toes, feet, hands, etc. in a live scan. The obtained images can be combined in any format including, but not limited to, an FBI, state, or international tenprint format.

[0039] The terms "finger characteristic information" and "hand characteristics information" are used to describe hand geometry information, such as finger and thumb lengths and spacing and minutiae extracted from print information.

[0040] The term "non-planar prism" includes a prism having a non-planar platen surface that extends around all or part of an axis of the prism, and whose non-planar platen surface allows for total internal reflection of light. A non-planar platen surface allows a print pattern (such as, a print pattern on a hand, a palm pocket, a writer's palm, a writer's palm with fingertips), or other hand characteristic images, to be captured. An example of this type of prism can be an approximately conically-shaped prism. Other examples can be approximately spherically shaped prisms, curved prisms, and the like.

[0041] Overall System

[0042] FIG. 1 shows a system 100 for capturing image data representing biometric data according to an embodiment of the present invention. System 100 includes a local section or unit 102 and a remote section or unit 104 (e.g., a computer, or the like) that can be coupled via a network 106. Network 106 can be any type of network or combination of networks known in the art, such as a packet-switched network with wired or wireless links, an intranet, the Internet, an Ethernet, or the like. Example links are links having a FIREWIRE or USB network interface. The remote section 104 may be in a same area as the local section 102, such that local and remote refer to an approximate distance they are relative to a final processing device of the image data (e.g., print or hand characteristic data).

[0043] Local section 102 includes a non-planar prism 108, having a non-planar portion (e.g., curved) that is symmetri-

cal about an axis of symmetry of the prism, positioned between a light source **110** and a scanning imaging system **112**. Scanning imaging system **112** can include a rotating imaging system **114** and a detecting system **116** (e.g., a camera). Scanning imaging system **112** captures image data from parts of a hand (not shown) interacting with non-planar prism **108**. The image data is processed in processing and control system **118**, which can generate one or both of an output signal and a communications signal, which can include the image data. The output signal can be transmitted to an optional output device **120**, while the communications signal can be transmitted to input/output (I/O) device **122**. The I/O device **122** then sends the output signal to remote section **104** over network(s) **106**.

[0044] It is to be appreciated that in other embodiments scanning imaging system **112** can include a stationary lens sized to capture all light leaving non-planar prism **108** that has been totally internally reflected from a section of the non-planar prism proximate an area in which a person (not shown) interacts with the non-planar prism **108** and a stationary large area array sensor.

[0045] Remote section **104** includes an I/O device **124**, a processing system **126**, and optionally an output device **128**. Processing system **126** can be used to process the image data to generate the biometric data. For example, extraction and matching operations can be performed on the image data to produce biometric data. Once completed, results can be displayed or audibly indicated using output device **128**. It is to be appreciated that other processes known in the biometric arts can also be performed in remote section **104**. All of these additional processes are contemplated within the scope of the present invention.

[0046] It is to be appreciated that network **106** and/or remote device **104** can be coupled to other peripheral devices and/or networks, which is contemplated within the scope of the present invention.

[0047] FIG. 2 shows local section **102** of system **100** according to an embodiment of the present invention. Rotating imaging system **114** can include a motor **200**, belt **202**, and pulley **204** that rotates rotating stage **206**, optical enclosure **208**, and detecting system **116** around an axis of symmetry of non-planar prism **108**. During rotation, positioning of rotating imaging system **114** can be monitored by controller **118** using signals from stop position sensor **210**, home position sensor **212**, and/or encoder system **214**. In this example, encoder system **214** is an optical position encoder receiving light on sensor **216** after the light interacts with strip **218**.

[0048] Although certain dimensions and/or types of devices are shown in this figure, these are not meant to be limiting, only exemplary. It is to be appreciated that different sizes or types of elements can be used within the scope of the present invention.

[0049] It is to be appreciated that, although not shown, various other types of devices can be used to rotate rotating imaging system **114**. For example, an electromagnetic device (e.g., stepper motor), a resilient device, or any other device known to one of ordinary skill in the art are all contemplated within the scope of the present invention. Thus, a motor/belt/pulley system is shown merely as one exemplary way to rotate rotating optical system **114**.

[0050] Exemplary aspects of system **100** can be found in U.S. Prov. Apps. 10/_____, entitled "System For Obtaining Print And Other Hand Characteristic Information Using A Non-Planar Prism," and 10/_____ entitled, "System Having A Rotating Optical System And A Non-Planar Prism That Are Used To Obtain Print And Other Hand Characteristic Information," (Atty. Ref. Nos. 1823.0820002 and 1823.0820004), both filed herewith, which are both incorporated herein by reference in their entireties.

[0051] Non-Planar Prism

[0052] FIG. 3 shows a cross-sectional view of non-planar prism **108** according to one embodiment of the present invention. Non-planar prism **108** has an opening **300** running along an axis of symmetry **302**. Opening **300** is defined within an area **304** of non-planar prism **108** that has a non-planar first portion **310** and a substantially planar second portion **312**. A section of top surface **306** of non-planar prism **108** can contain a guide or positioning device **314**, which is used to properly place a subject's hand (see FIGS. 15-16) during biometric image capture.

[0053] Non-planar prism **108** can be manufactured from transparent, translucent, and/or colored acrylic, glass, plastic, or the like, and may be coated with various protective coatings, as is known in the relevant arts. If the non-planar prism material is colored, it can be of a color that matches a color of light for a light source being used. A first surface **306** of first section **310** is shaped so as to provide the non-planar aspect to prism **108**. As discussed above, the non-planar shape is preferably approximately conical, but can also be curved, spherical, or the like, so long as a second surface **316** provides total internal reflection of incident light.

[0054] Platen surface **306** is a surface upon which an object (e.g., a hand(s)) having a print is placed. Platen surface **306** can be a surface of non-planar prism **108** or another surface in optical contact with an outside surface of prism **108**. For example, platen surface **306** can be a surface of an optical protective layer (e.g., silicone pad) placed on prism **108** at section **310**.

[0055] During operation, the subject's hand is positioned using positioning device **314** (see FIGS. 15-16). Light enters non-planar prism **108** through an input face or portion either from within opening **300** or via an edge **318** of opening **300**. The light totally internally reflects from second surface **316** out second or exit section **312** through rotating imaging system **114** onto detector **116**. Examples of image capturing configurations are found in U.S. Ser. No. 10/_____ entitled, "System Having A Rotating Optical System And A Non-Planar Prism That Are Used To Obtain Print And Other Hand Characteristic Information," (Atty. Doc. No. 1823.0820004).

[0056] Through use of the shape shown for non-planar prism **108**, substantially all or part of a hand (e.g., thenar and/or hypothenar region of the palm, the "writer's palm," inter digital regions, palm heel, palm pocket, and/or fingertips) (see FIGS. 17-21) can be captured in one or more scans. This is partially because a surface area of section **310** is sized to receive one or more hands wrapped around non-planar prism **108** generally along a direction of a curve. Accordingly, in embodiments, images with features of up to two hands of a subject can be captured in a single scan.

Examples of image capture methods can be found in U.S. Ser. Nos. 10/_____ entitled "Biometric System For Capturing Print Information Using A Coordinate Conversion Method," 10/_____ entitled "Methods For Obtaining Print And Other Hand Characteristic Information Using A Non-Planar Prism," and 10/_____ entitled "System And Method For Generating A Preview Display In A Print Capturing System Using A Non-Planar Prism" (Atty. Doc. Nos. 1823.0820006, 1823.0820007, and 1823.082000A), all filed herewith, and which are all incorporated herein by reference in their entireties.

[0057] FIGS. 4-5 show possible dimensions for non-planar prism 108 according to an embodiment of the present invention. In this example, non-planar prism 108 is approximately a 45 degree by 45 degree by 90 degree non-planar prism, with respect to opening 300. Other angles can be used as long as total internal reflection is maintained to allow capture of print images. Also, in this example, a diameter D1 of opening 300, a diameter D2 of positioning device 314, and a diameter D3 of non-planar prism 108 are shown in FIG. 5. These diameters are exemplary, and not intended to limit the invention in any way. It is to be appreciated that other dimensions for these diameters could also be used (e.g., larger or smaller).

[0058] FIGS. 6-8 show stages of surface 600 of non-planar prism 108 when surface 600 undergoes a smoothing process.

[0059] In FIG. 6, surface 600 is shown after receiving a machine finish. It is to be appreciated that this figure is not drawn to scale. The roughness of surface 600 is exaggerated for purposes of illustration. The machine finish can be achieved using a mill, a lathe, a shaper, a machine tool, a human tool, a cast, a grinder, a polisher, or the like. These tools usually leave surface 600 with the machine finish. A certain roughness can occur at a machine finish of less than 32 micro inches root mean square. Another finishing method can be to use a diamond turned surface device, which leaves surface 600 closer to optical quality finish. Typically, the machine finish may appear and feel smooth, but it can be orders of magnitudes away from being an optical quality finish. For example, the machine finish can have valleys and grooves of about 16 micro inches, while optical quality is typically measured in wavelengths of light.

[0060] In FIG. 7, a protective refractive index matched coating 700 can be applied over the machine finish. The coating 700 can be transparent and have a viscosity that allows it to flow into and fill rough contours of surface 600 to obtain a high quality optical finish. The coating 700 can be applied through various techniques (e.g., dipping, spinning, vapor deposition, sputter deposition, spraying, etc.). The technique chosen can vary based on a type of coating material used, its viscosity, and its curing requirements. In some cases, dielectric materials in the coating can retain a large electrostatic charge, which is known to attract and retain undesirable particles of dust, dirt, and other foreign materials. The addition of an optically clear, electrically conductive material within coating 700 can be utilized to eliminate this problem.

[0061] In FIG. 8, surface 306 is shown as an optically finished surface. After the coating 700 is applied, excess coating can be removed. The remaining surface is cured (e.g., using air drying, UV radiation, heat, or the like).

[0062] Use of coating 700 can facilitate the application of an optical target (see element 2292 in FIG. 22) on surface

306 of non-planar prism 108. Target 2292 may be applied by a variety of techniques (e.g., silk screening, stamping, photo transfer, laser engraving, mechanical engraving, etc.). Target 2292 can be a calibration target or other information desired in a particular application. Coating 700 can also provide protection of the prism surface from mechanical damage.

[0063] FIGS. 9-11 show a side, bottom perspective, and top perspective view, respectively, of non-planar prism 108, according to various embodiments of the present invention. These figures also show, although not to scale, scan sections 900 (e.g., radial scan line images) that can occur during scanning of a subject's hand (or hands). For example, as described above, scanning image capture system 112 can take images at each scan section 900 that are later processed to form a hand print image and/or used to determine print, finger, or hand characteristic information.

[0064] FIG. 9 includes opening 300 that includes opening edge 318 that can have various finishes, such as a chamfered finish. For example, non-planar prism 108 can have a chamfered finish to edge 318 when configured for use with inside edge light sources. In contrast, as seen in FIG. 10, opening edge 318 can be squared, which is used for light sources that are inserted into section 300. Although not shown, a non-planar prism 108 can have an outside edge that is chamfered, which can be used with an outside edge light source. Still other configurations of non-planar prism 108 can be used to comply with other light source positions, which are all contemplated within the scope of the present invention.

[0065] FIGS. 12-13 show non-planar prisms 1200 and 1300, respectively, according to various other embodiments of the present invention. In FIGS. 12 and 13, non-planar prisms 1200 and 1300 have multi-faceted sections, that is they have multiple individual planar sections 1202-*n* and 1302-*n* arranged about an axis, where *n* is an integer (shown as *n*=1 and *n*=2 in the figures). It is to be appreciated that in an embodiment in which *n* approaches infinity (e.g., possibly 1000 planar sections 1202 or 1302 per inch), an outer surface of prism 1200 and 1300 can appear and feel smooth, similar to prism 108.

[0066] Prisms 1200 and 1300 shown in FIGS. 12-13 also have first and second non-planar sections (e.g., surfaces) 1204/1206 and 1304/1306, in contrast to only one non-planar section in prism 108 in previous configurations. Thus, both top 1204 or 1304 and bottom 1206 and 1306 portions of prisms 1200 and 1300 in FIGS. 12 and 13 have non-planar surfaces, which is in contrast to prism 108 that has a planar base.

[0067] In one embodiment, sections 1202 and 1302 are discrete, planar sections that form multi-faceted portions of prisms 1200 and 1300. This is in contrast to prism 108 that may be unitary and have a smooth contour and a circular circumference. Although shown with a certain number of sections 1202 and 1302, other numbers of sections 1202 and 1302 can also be used without departing from the scope of the present invention. Prisms 1200 and 1300 including individual facet sections 1202, 1302 can be formed as unitary structures or from individual sections coupled together.

[0068] FIG. 14 shows a non-planar prism 1400 according to an embodiment of the present invention. Non-planar

prism **1400** has a same general shape as non-planar prism **108**, except it contains a cavity **1402** that can be filled with a liquid, fluid, gel, solid, or gas medium or material **1404**. The medium or material **1404** can be chosen so that it has a similar or substantially same refractive index as non-planar prism surface **1406**, although having a different refractive index is also contemplated within the scope of the present invention. A closing device **1408** (e.g., a cap) can be used to seal cavity **1402**.

[**0069**] FIGS. **15-16** illustrate how a subject places one hand **1500** or both hands **1600** on a non-planar prism (e.g., prism **108**). As can be seen, positioning device **314** in used is either case to properly align the hand **1500** or hands **1600** on non-planar prism **108** for image capture. This is also true when a positioning device of prisms **1200**, **1300**, or **1400** is used.

[**0070**] Although not shown in this figure, it is to be appreciated that a subject can also place an entire hand **1500** on either side of the positioning device **314** in order to capture both hands **1600** in a single scan. Using a non-planar prism allows for all portion of a hand **1500** or hands **1600**, including a palm pocket, to be captured, as shown in FIG. **21**.

[**0071**] Further, although not specifically shown in FIGS. **15 and 16**, a subject can place one or both hands on non-planar prism **108** writer's palm side down on platen surface **306** so as to capture a writer's palm. Also, a subject can place one or more writer's palms and fingertips down to capture an image of a writer's palm and fingertips in a single scan, see FIG. **20**.

[**0072**] Captured Hand Sections

[**0073**] FIGS. **17-22** show examples of various aspects of a hand or palm that can be imaged in order to generate biometric information or data. These are merely exemplary areas of a hand or palm. Other areas can be imaged, as would be apparent to a person skilled in the art given this description. These examples are not meant to limit the invention.

[**0074**] FIG. **17** shows sections **1702-1714** of a palm **1700** of a hand **1716** that can be imaged, according to embodiments of the present invention. Section **1702** is a first interdigital area. Section **1704** is a second interdigital area. Section **1706** is a third interdigital area. Section **1708** is a fourth interdigital area. Section **1710** is a thenar area. Section **1712** is a hypothenar area.

[**0075**] Section **1714** is a central area or palm pocket.

[**0076**] FIG. **18** shows creases **1800-1804** of palm **1700** that can be included in an image, according to embodiments of the present invention. Crease **1800** is a thenar crease. Crease **1802** is a proximal transverse crease. Crease **1804** is a distal transverse crease.

[**0077**] FIG. **19** shows a writer's palm or writer's palm hypothenar area **1900** of palm **1700**. Writer's Palm **1900** includes a print pattern (ridges and valleys) that extends from palm hypothenar area **1712** up along a side of the hand.

[**0078**] FIG. **20** shows images **2000** of right (R) and left (L) hand writer's palms **1900** and fingertips **2002**, according to an embodiment of the present invention.

[**0079**] According to a feature of the present invention, writer's palm **1900** and fingertips **2002** can be captured in a

single scan because of the shape of non-planar prism **108**. Unlike conventional planar platen surfaces, writer's palm **1900** and fingertips **2002** can be placed on a non-planar prism **108** at the same time during a live scan without requiring any difficult or awkward contortions of a persons hand.

[**0080**] FIG. **21** shows images **2100** of right and left hand prints captured during two scans of scanner **112** according to an embodiment of the present invention.

[**0081**] FIG. **22** shows an exemplary image **2200** including image data of both a hand print and/or hand characteristic information **2290** and calibration data **2292**. This can include any print information described above, including writer's palm and/or writer's palm and fingertip information. This may produce more readily admissible evidence under the Federal Rules of Evidence based on capturing and storing together the calibration data and the image data.

[**0082**] Capturing calibration data can be used to reproduce substantially exactly the image as originally captured. This is especially helpful as data is achieved and subsequently accessed at different times by different systems and applications. Such systems and applications can access both the image data and calibration data in an original scan to enable successful, high-quality reproduction or analysis of the captured image data with appropriate calibration. Also, calibration data can be used to ensure system **100** is calibrated to capture a consistent and accurate image **2200**. For example, system **100** can be calibrated each time scanning system **112** scans calibration data on non-planar prism **108**.

[**0083**] As described above, the non-planar surface of the non-planar prism allows for a pocket of a palm of hand to make contact with a platen and break a surface total internal reflection of the non-planar prism. This creates a mechanism for capturing a high contrast round palm print image. According to further embodiments, a print image can also be captured that includes both a palm print and one or more fingerprints on a same hand. In this way, other biometric information can be extracted from the print images, such as, the association of the palm and fingerprints as belonging to the same hand, distance information on the distance from palm locations to finger locations, etc. According to still further embodiments, both a hand print and target/calibration information can be captured at a same time and stored together.

[**0084**] Conclusion

[**0085**] While various embodiments of the present invention have been described above, it should be understood that they have been presented by way of example only, and not limitation. It will be apparent to persons skilled in the relevant art that various changes in form and detail can be made therein without departing from the spirit and scope of the invention. Thus, the breadth and scope of the present invention should not be limited by any of the above-described exemplary embodiments, but should be defined only in accordance with the following claims and their equivalents.

What is claimed is:

1. A prism used in a system configured to capture image data representative of biometric data, comprising:

a non-planar first portion that is symmetrical about an axis of symmetry of the prism and is configured to receive a portion of a body of a user; and

- a substantially planar second portion coupled an angle with respect to the non-planar first portion.
2. The prism of claim 1, wherein the first portion comprises radial sections coupled at predetermined angles with respect to each other.
3. The prism of claim 1, wherein the first portion comprises a conical shape.
4. The prism of claim 1, further comprising a cavity defined between the first portion and the second portion.
5. The prism of claim 4, further comprising a medium held within the cavity, the medium including one of a fluid, a liquid, a gel, and a gas.
6. The prism of claim 4, further comprising a medium held within the cavity, the medium having a same refractive index as the prism.
7. The prism of claim 1, further comprising a cylindrical opening running from the first portion to the second portion along the axis of symmetry, wherein the cylindrical opening is configured to receive a light source whose light beams are totally internally reflected from an inside surface of the first portion, such that they exit through the second portion.
8. The prism of claim 1, wherein an outside surface of the first portion comprises a protective coating.
9. The prism of claim 1, wherein the prism is manufactured from at least one of acrylic, glass, plastic, colored material, and clear material.
10. The prism of claim 9, wherein the colored material is the same color as a light source being used.
11. The prism of claim 1, wherein the first portion comprises a curved shape.
12. The prism of claim 1, wherein the first portion comprises a spherical shape.
13. The prism of claim 1, wherein the first portion comprises a target section configured to be captured along with the biometric data and configured to be used for calibrating the biometric data during output of the biometric data.
14. The prism of claim 1, further comprising a positioning device extending from the first portion and configured to be used to ensure the portion of body of the user is properly placed on the first portion.
15. The prism of claim 1, wherein the portion of the body of the user comprises one of one hand or two hands.
16. The prism of claim 1, further comprising a cylindrical opening running from the first portion to the second portion along the axis of symmetry, wherein the cylindrical opening includes a chamfered edge configured to receive light from a light source whose light beams are totally internally reflected from an inside surface of the first portion, such that they exit through the second portion.
17. The prism of claim 1, wherein an intersection of the first portion and the second portion comprises a chamfered edge configured to receive light from a light source whose light beams are totally internally reflected from an inside surface of the first portion, such that they exit through the second portion.
18. The prism of claim 1, wherein:
- the first portion comprises an input face and a platen face; and
- the second portion comprises an exit face.
19. The prism of claim 18, wherein:
- the input face is configured to receive therethrough light from a light source;
- the platen face has a first surface configured to receive the portion of the body of the user and a second surface configured to totally internally reflect the light from the light source; and
- the light that has been totally internally reflected from the platen face exits the prism via the exit face.
20. The prism of claim 18, wherein a first surface of the platen face is curved, such that the portion of the body of the user wraps around the first surface in a curve directed that extends generally along a direction of the curve.
21. The prism of claim 18, wherein a surface area of the platen face is larger than a surface area of the exit face.
22. A prism configured to be used in a system for capturing image data representative of biometric data, comprising:
- an input portion configured to receive light from a light source;
- a non-planar platen portion that is symmetrical about an axis of symmetry of the prism, the platen portion being configured to receive a portion of a body of a user on a first surface and configured to totally internally reflect the light from the light source off a second surface; and
- an exit portion configured to pass the light that has been totally internally reflected from the second surface of the platen portion onto a detector that is configured to perform the capturing of the image data.
23. A prism configured to be used in a system for capturing image data representative of biometric data, comprising:
- a non-planar first portion symmetrical about an axis of symmetry of the prism, the first portion being configured to receive a portion of a body of a user on a first surface and configured to totally internally reflect illumination from a second surface; and
- a non-planar second portion symmetrical about the axis of symmetry of the prism and coupled to the first portion, the second portion being configured to pass light that has been totally internally reflected from the second surface of the first portion onto a detector that is configured to perform the capturing of the image data.
24. The prism of claim 23, wherein the first and second portions are multi-faceted.
25. The prism of claim 23, wherein the first and second portions comprise multiple discrete sections coupled together, such that the first and second surfaces are a multi-faceted.