

H. F. SNYDER.
GEARING.
APPLICATION FILED SEPT. 6, 1912.

1,167,126.

Patented Jan. 4, 1916.
3 SHEETS—SHEET 1.

Fig. 1.

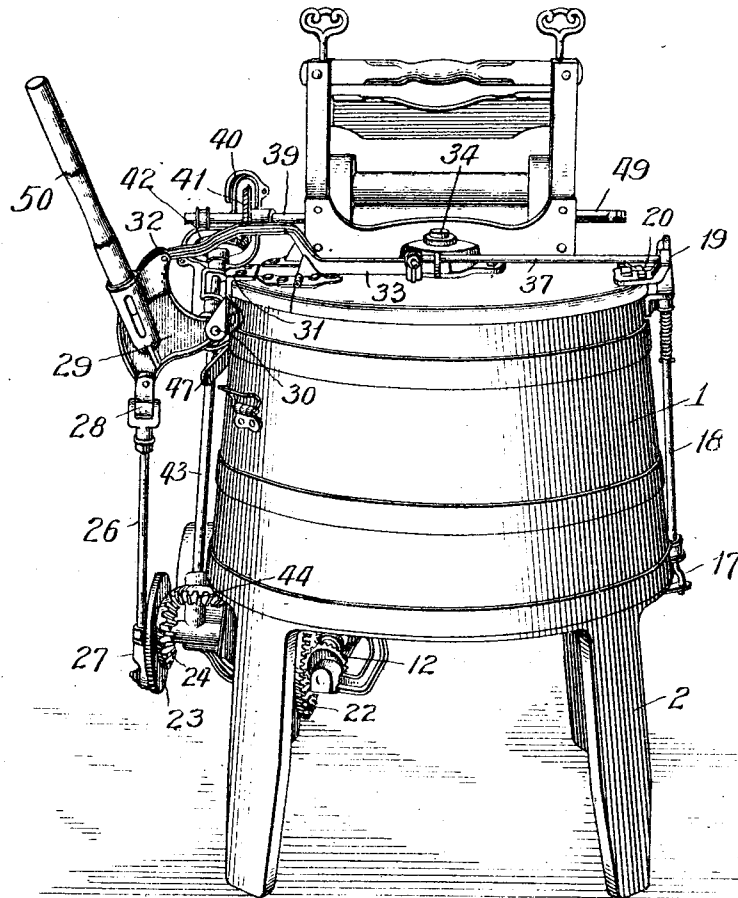

Witnesses:
John Enders
F. A. Hall

Inventor:
Howard F. Snyder,
Wallace R. Lane,
Atty.

H. F. SNYDER.
 GEARING.
 APPLICATION FILED SEPT. 6, 1912.

1,167,126.

Patented Jan. 4, 1916.
 3 SHEETS—SHEET 2.

Fig. 2.

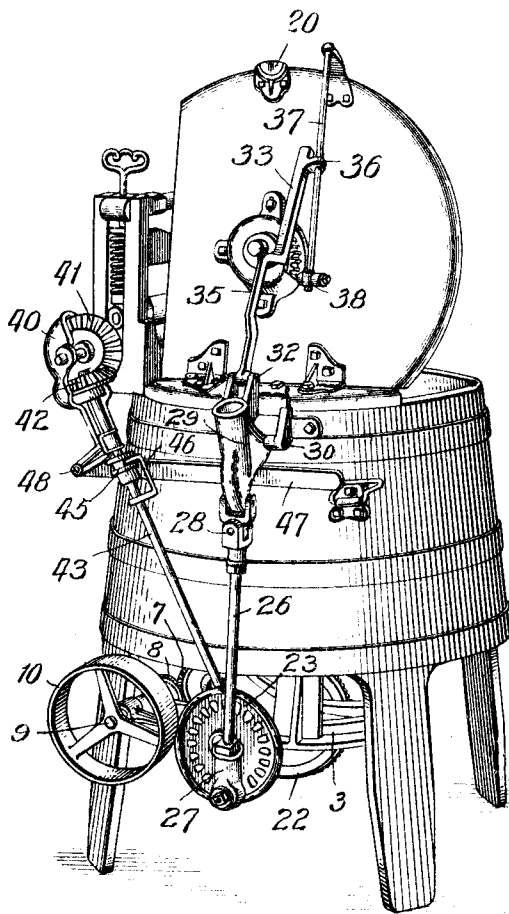
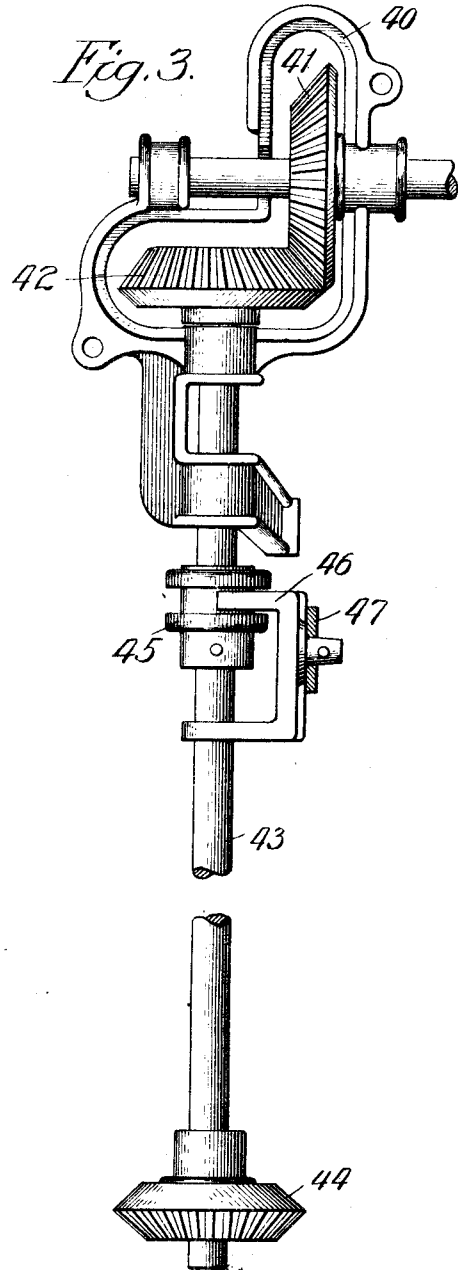

Fig. 3.



Witnesses:
 John Enders
 F. A. Florell.

Inventor:
 Howard F. Snyder,
 by Wallace R. Lane,
 Atty.

H. F. SNYDER,
GEARING.
APPLICATION FILED SEPT. 6, 1912.

1,167,126.

Patented Jan. 4, 1916.
3 SHEETS—SHEET 3.

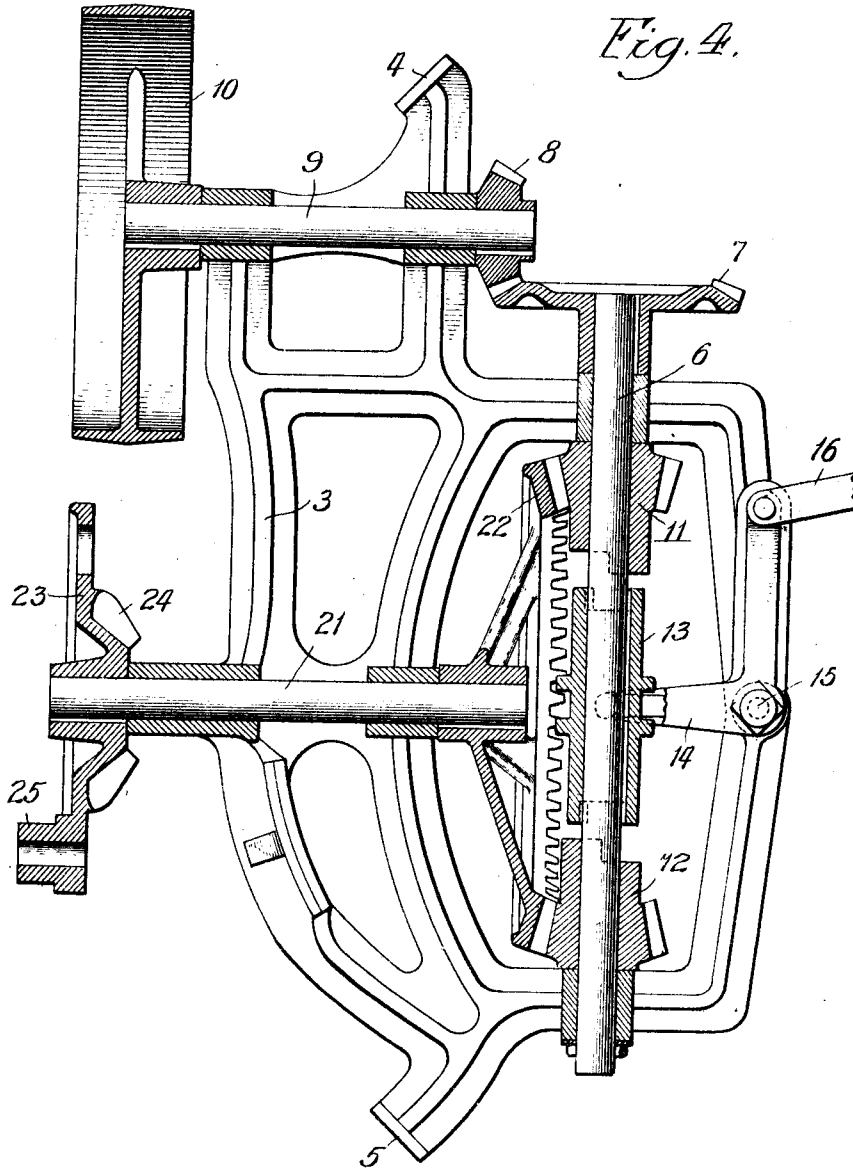

Witnesses:
John Enders
T. W. Phell.

Inventor:
Howard F. Snyder,
by Wallace R. Lane.
Attorney

UNITED STATES PATENT OFFICE.

HOWARD F. SNYDER, OF NEWTON, IOWA, ASSIGNOR TO THE MAYTAG COMPANY, A CORPORATION OF IOWA.

GEARING.

1,167,126.

Specification of Letters Patent.

Patented Jan. 4, 1916.

Application filed September 6, 1912. Serial No. 718,864.

To all whom it may concern:

Be it known that I, HOWARD F. SNYDER, a citizen of the United States, residing at Newton, county of Jasper, State of Iowa, have invented new and useful Improvements in Gearing, of which the following is a specification.

It is the object of the present invention to provide a gearing or gear mechanism particularly adapted for use in connection with washing machines.

More particularly it is the object to provide a gearing compact and rugged in construction and simple in character whereby the agitator of a washing machine may be driven and whereby a wringer may be operated, suitable control mechanism being provided for governing the movement of the agitator and of the wringer when the gearing is driven from a power source such as an engine or motor.

The details of the present invention together with the special objects and advantages thereof will be made clear by the following detailed description which is to be taken in conjunction with the accompanying drawings wherein—

Figure 1 is a front view of a washing machine provided with gearing of the present invention. Fig. 2 is a side view of the same machine with the cover partially raised, the covering for the wringer gears having been removed to expose the gears. Fig. 3 is a detail of the wringer gearing and Fig. 4 is a plan view, partly in section, of the mechanism under the tub.

In the embodiment illustrated, a tub 1 carried on legs 2 is provided with a rigid gear frame of the construction illustrated in Fig. 4. The gear frame 3 is a rigid compact casting provided with ears 4 and 5 through which bolts may be passed for supporting the frame from two of the tub legs and independent of the tub. Much of the gearing for the washer is supported and carried by this rigid frame 3.

The power shaft 6 is mounted lengthwise of the frame and carries at its outer end a bevel gear 7 meshing with a smaller gear 8 carried on a transverse shaft 9 whereon a drive pulley 10 is mounted. The geared relation between shafts 9 and 6 not only give a desirable speed reduction between the pulley and the power shaft but also places the pulley in advantageous position low

down at the side of the structure where it is out of the way and where there is little danger of tipping the machine through improper action of the drive belt. The power shaft 6 also carries beveled gears 11 and 12 mounted loosely thereon and having their inner faces shaped to form engaging lugs for cooperating with a sliding clutch member 13 keyed to the shaft and having an annular groove engaging with the forked arm 14 of a bell crank lever pivoted at 15 and actuated by a link member 16 which extends across below the tub to a crank 17 (Fig. 1) provided at the end of a vertically positioned rock shaft 18 which extends up along the side of the tub through suitable bearings and carries a hand grip 19 capable of swinging around into contact with the metal plate 20 carried by the cover of the tub, thereby to serve as a latch or lock for the cover. With the handle 19 in lock engagement with the cover plate 20 the sliding clutch member 13 will be in driving engagement either with the beveled gear 11 or with the beveled gear 12 depending upon whether the crank 17 has been rocked outward or inward by the twisting movement given to the handle 19.

The gear frame carries a counter-shaft 21 having a large beveled gear 22 meshing continuously with the beveled gears 11 and 12 so that when the clutch member 13 is thrown completely in either direction, power will be transmitted from the power shaft 6 to the counter-shaft 21, the direction of rotation of the shaft 21 depending upon the direction in which the clutch member 13 was shifted by manipulation of the handle 19. The outer or exposed end of the counter-shaft 21 carries a rigidly mounted crank disk 23, carrying on its inner face a beveled gear 24 and carrying on its outer face a crank 25 provided with a bolt hole for more secure attachment of a suitable pitman.

The pitman 26 through which power is delivered from the crank disk 23 is connected with the disk through a suitable cast head 27 and is provided at its upper end with a double clevis 28 attached to a massive bell crank 29 pivotally mounted to a suitable casting secured to the side of the tub, this casting preferably overlapping the stationary portion of the tub top at 31 to afford greater security of attachment. The other arm of the bell crank is pivotally

connected at 32 with a rack bar 33 provided at its side face with teeth meshing with a spur gear carried on the top of the agitator shaft 34 and suitably housed in accordance with normal practice. The rack bar 33 is offset near its middle at 35 and it carries at its outer end an eye 36 shaped for sliding engagement along a guide rod 37 mounted parallel to the cover of the tub and supported at its inner end by a lug 38 positioned to hold the rack to its work while in service.

With the cover closed, a swinging movement of the handle 19 will throw in the power clutch and start the crank disk 23 which, through the up and down motion of the pitman 26, will rock the bell crank 29, thus pushing the rack bar forward and backward and giving to the agitator an alternating reciprocating movement. It is an important feature of this embodiment that the bell crank or swinging casting 29 swings toward and from the dolly post to push the rack bar forward and backward along the guide rod 37 and in mesh with the dolly pinion. When the cover of the machine is to be opened, the handle 19 is turned through ninety degrees and out of engagement with the plate 20, this movement serving at the same time to shift the clutch member 13 out of driving connection with one of the gears 11 or 12 and into an intermediate or idle position between these two gears. Then the cover of the tub may be swung upward as shown in Fig. 2 without any unhooking or manipulation of the rack bar other than that produced automatically through the lifting action of the guide rod 37 at the eye 36. The upward swinging movement of the cover serves to lift the rack out of mesh with the pinion, swinging the rack upward as shown in Fig. 2 with a sliding movement of the eye 36 along the rod 37 until, when the cover is completely open, the eye 36 will be positioned almost directly above the pivotal point 32 of the bell crank. Then the clutch under the tub can be thrown in again by manipulation of the handle 19 and the rocking movement of the bell crank 29 will produce at the rack bar only a very slight longitudinal motion and inasmuch as the rack bar will be out of mesh with the dolly pinion, no movement of the dolly will result and the machine as a whole will be in much the same condition as if the rack bar had been detached from the bell crank 29 as by removal of the pivot pin at 32. When the cover is to be closed, it can be swung down and locked in closed position without the necessity for attention to the rack bar, that bar slipping into its place automatically as the cover is lowered.

The embodiment here disclosed as illustrative of the present invention includes driving connections for a wringer mounted on the rear of the tub. This wringer may be of

usual construction with two roller shafts geared together, one of those shafts being extended outward at 39 to support a gear housing 40 preferably provided with a removable cover for giving access to the gearing within. The wringer gearing comprises a beveled gear 41 mounted on the wringer 39 and meshing with a similar gear 42 feathered to an auxiliary drive shaft 43, the feathered connection being such that the shaft 43 can slide through the gear when desired. The lower end of the auxiliary shaft carries a beveled gear 44 (Fig. 3) meshing with the beveled gear 24 of the crank disk. Shaft 43 also carries a rigidly mounted boss 45 having a slot engaged by the forked end 46 of a member pivoted to a hand lever 47 positioned at the side of the tub and pivoted at 48 to a bracket suitably supported below the wringer gears. A downward swinging movement of the handle 47 shifts the shaft downward sliding it through the gear 42 until the gear 44 at its lower end comes into meshing engagement with the gear 24 of the crank disk. This establishes driving connection to the wringer so that power supplied at the pulley 10 can be used for driving the wringer. The direction of rotation of the wringer is governed by the position of the handle 19 and the associated crank 17 and the wringer can be instantly started, stopped or reversed simply by manipulation of the handle 19. Whenever the wringer is in use with the tub cover open, there will still be a pivotal connection between the bell crank 29 and the dolly rack bar but the substantially vertical position of that bar and its disengagement from the dolly pinion will prevent the delivery of power to the dolly post and will result in substantially nothing more than a free to and fro sidewise swing of the rack bar with very little endwise movement. Simultaneous operation of the wringer and the dolly is possible, and when the dolly alone is to be operated, the lever 47 is lifted to shift the auxiliary shaft upward far enough to disengage its gear 44 from its cooperating gear.

The crank drive simplifies the power transmission and through the agency of the bell crank establishes a to and fro movement at the top of the tub without the necessity for lifting any considerable amount of gearing when the cover is raised or for detaching any of the driving elements before the cover can be opened. The wringer driving mechanism is free from exposed parts in which clothing or fingers might be caught. If desired, the wringer may be equipped with an ordinary handle applied to the shaft at 49 and the bell crank 29 may be provided with an operating handle 50 fitted in a suitable socket so that in case of power failure, the washing and wringing may be completed independently of the gearing mechanism under the tub.

70

75

80

85

90

95

100

105

110

115

120

125

130

I am aware that various features of the construction here disclosed may be changed and that modifications in detail and in grouping may be effected without departing from the spirit of my invention as defined by the appended claims.

What I claim as new and desire to secure by Letters Patent of the United States is:

1. In gearing mechanism the combination of a support, a member hinged to the support, a vertical shaft in said member a pinion thereon, a reciprocatory rack bar for engagement with said pinion to oscillate the vertical shaft, means upon the support to reciprocate said rack bar and having a pivotal connection therewith, a guide upon the hinged member parallel with the rack bar and adapted to cause the same to move accurately into and out of mesh with the pinion as the hinged member is lowered or raised.

2. In a gearing mechanism, the combination of a support, a hinged member carried thereby, a vertical shaft supported in said hinged member, a gear on the upper end of said shaft, a rack bar having driving engagement with said gear, a guide bar along which said rack bar slides, a bell crank pivoted at the side of said support and connected to move said rack bar with a forward

and backward motion with respect to said vertical shaft, a pitman connected to drive said bell crank, a crank disk connected to drive said pitman, a counter shaft on which said crank disk is mounted, a power shaft, and a gearing between said power shaft and said counter shaft.

3. In a gearing mechanism, the combination of a power shaft, bevel gears loosely mounted thereon, a sliding clutch member movable along said shaft into driving engagement with either of said gears, a counter shaft, a bevel gear on said counter shaft permanently meshing with both bevel gears on said power shaft, a crank actuated by said counter shaft, a pitman driven by said crank, a vertically disposed rotary shaft, and means for driving said vertical shaft from said pitman with an alternately reversing motion irrespective of the direction of rotation of the counter shaft, whereby reversible mechanism may be directly driven from the latter.

In witness whereof, I hereunto subscribe my name to this specification in the presence of two witnesses.

HOWARD F. SNYDER.

Witnesses:

W. L. PICKENS,
W. H. A. THOMAS.