

(No Model.)

F. BAUGH.  
MOLDER'S FLASK.

No. 450,802.

Patented Apr. 21, 1891.

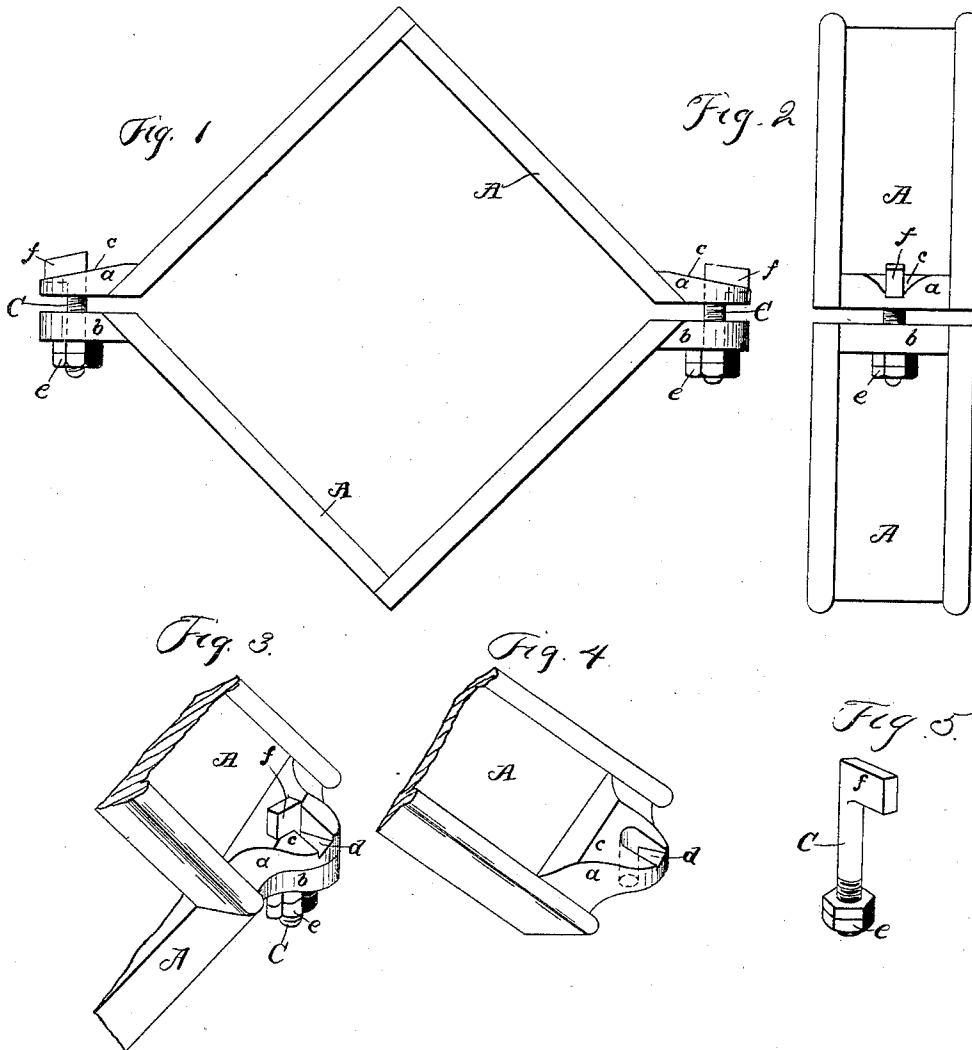

WITNESSES:  
*J. C. ...*  
*Ed. Smith*

INVENTOR  
*Fredrick Baugh.*  
BY *And. W. Bond*  
ATTORNEY.

# UNITED STATES PATENT OFFICE.

FREDERICK BAUGH, OF ALLIANCE, OHIO.

## MOLDER'S FLASK.

SPECIFICATION forming part of Letters Patent No. 450,802, dated April 21, 1891.

Application filed February 24, 1891. Serial No. 382,503. (No model.)

*To all whom it may concern:*

Be it known that I, FREDERICK BAUGH, a citizen of the United States, residing at Alliance, in the county of Stark and State of Ohio, have invented certain new and useful Improvements in Molders' Flasks; and I do hereby declare that the following is a full, clear, and exact description of the same, reference being had to the annexed drawings, making a part of this specification, and to the letters of reference marked thereon, in which—

Figure 1 is a top view showing the flask open. Fig. 2 is a side view showing the flask open. Fig. 3 is a view showing a portion of the flask, showing the same locked. Fig. 4 is a detached view of a portion of one of the flask sides and its arm. Fig. 5 is a detached view of the clamping-bolt.

The present invention has relation to molders' flasks; and it consists in the different parts and combination of parts hereinafter described, and particularly pointed out in the claims.

Similar letters of reference indicate corresponding parts in all of the figures of the drawings.

In the accompanying drawings, A represents the flask, which may be of any desired size or shape, reference being had to the kind and size of castings to be made.

The flask A is provided with the arms or extensions *a* and *b*, which are located upon the flask substantially as illustrated in Fig. 1 and are attached to the flask A in any convenient and well-known manner.

In the manufacture of square flasks, such as shown in Fig. 1, the corners B are securely fastened, thereby forming the flask proper in two sections or halves. The arms or extensions *a* are provided with the inclined faces *c* and the grooves *d*, which are for the purposes hereinafter described. The arms *a* and *b* are each provided with apertures, which are for the purpose of receiving the clamping-bolt C, which clamping-bolts are located substantially as illustrated in the drawings. One end of the clamping-bolts is screw-threaded, and they are so formed for the purpose of receiving and holding the screw-threaded nuts *e*, and for the purpose of better holding the

clamping-bolts C at the desired point of adjustment two nuts *e* are located upon each of the clamping-bolts C.

The clamping-bolts C are each provided with the head *f*, which head is located upon one side of the shank of the clamping-bolts C. When it is desired to lock the flask A, the clamping-bolts C are turned, so as to bring the head *f* into engagement with the inclined faces *c*, thereby securely clamping the two sections of the flask A together. The recess *d* is for the purpose of receiving the head *f* and thereby preventing the clamping-bolt C from turning when the flask is open or the sections parted, as illustrated in Figs. 1 and 2.

The object and purpose of forming the flask proper in section and providing a means for parting the sections is to provide a means for removing the sand from the flask A after the casting or castings have been made. It will be understood that by my peculiar arrangement I am enabled to easily remove the sand from the flask A by simply parting the sections and after the sand has been removed securely adjust and lock the sections for further use. Heretofore difficulty has been experienced in removing the sand from the flask, and especially so when the sand adheres to the sides of the flask.

It will be understood that in the event that two flasks are to be placed one on the top of the other they should be clamped together in the ordinary manner. It will be also understood that the recess *d* can be dispensed with, as its only object is to prevent any accidental movement of the head *f*.

By forming the sections A without hinges I am enabled to part the entire body of each section, and thereby remove or set away the entire portion of each section from the sand contained in said section.

Having fully described my invention, what I claim as new, and desire to secure by Letters Patent, is—

1. The combination of the flask A, formed in sections and provided with the arms or extensions *a* and *b*, the inclined faces *c*, located upon the arms or extensions *a*, the grooves or recesses *d*, located upon the inclined faces *c*, and the clamping-bolts C, substantially as and for the purpose specified.

2. In a molder's flask, the non-hinged portable sections A, provided with the arms or extensions *a* and *b*, the extensions *a*, provided with the inclined faces *c*, and the clamping bolts C, provided with the head *f*, substantially as and for the purpose specified.

5 In testimony that I claim the above I have

hereunto subscribed my name in the presence of two witnesses.

FREDERICK BAUGH.

Witnesses:

C. W. ROCH,  
S. F. KEITH.