

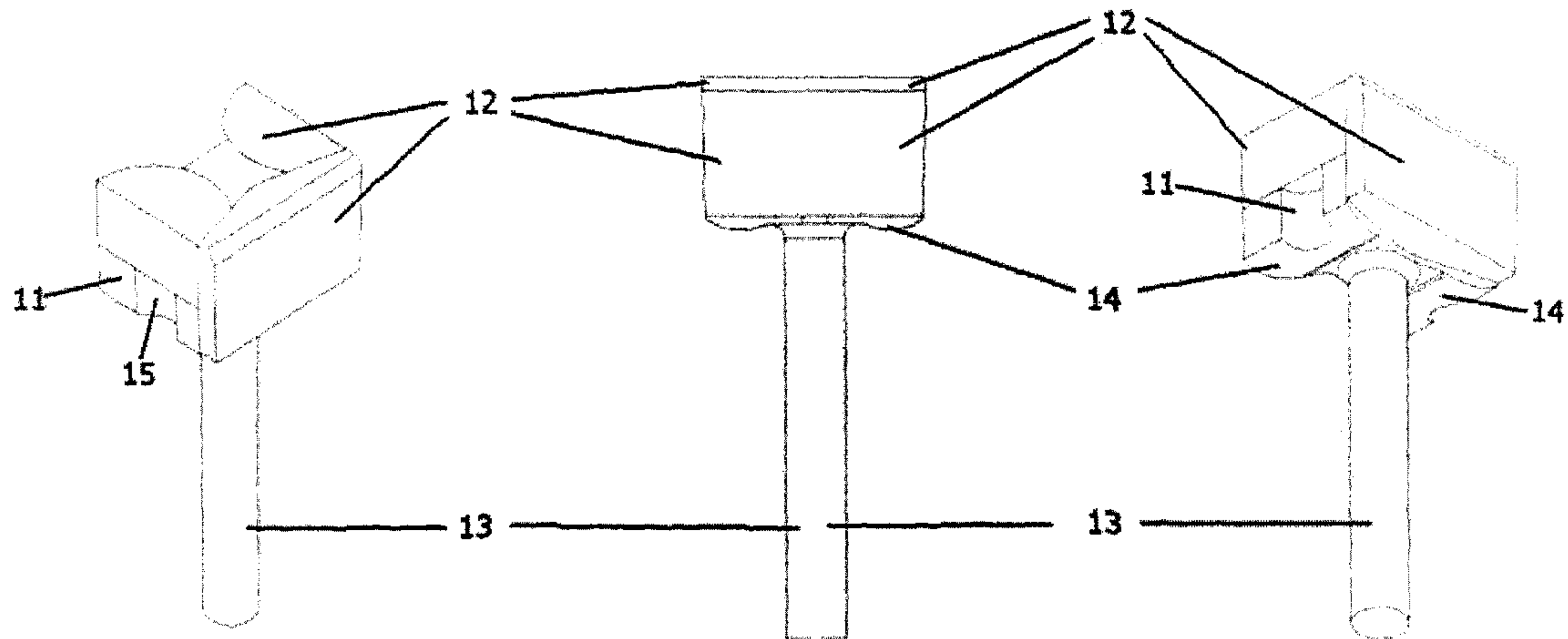

(22) Date de dépôt/Filing Date: 2016/04/28
(41) Mise à la disp. pub./Open to Public Insp.: 2016/10/29
(45) Date de délivrance/Issue Date: 2018/05/01
(30) Priorité/Priority: 2015/04/29 (DE10 2015 207 927.9)

(51) Cl.Int./Int.Cl. *B30B 15/28* (2006.01)
(72) Inventeurs/Inventors:
FRANGENBERG, MEINHARD, DE;
SCHNEPPER, JORG, DE
(73) Propriétaire/Owner:
TAKRAF GMBH, DE
(74) Agent: KIRBY EADES GALE BAKER

(54) Titre : PROTECTION CONTRE L'USURE LATÉRALE DE ROULEAU DE PRESSE A ROULEAUX
(54) Title: SIDE WEAR PROTECTION FOR THE ROLLER OF A ROLLER PRESS



(57) **Abrégé/Abstract:**

The side wear protection according to the invention and for the roller of a roller press consists of several side wear protection elements surrounding the roller edge. According to the invention the side wear protection elements have a base body consisting of an ductile material. Furthermore, the base body has a threaded bolt on the side of the base body directed toward the roller axis. Hard bodies are preferably fastened on the cover side and on the front side of the base body. The hard bodies are preferably manufactured from FeCrMoVC.

Abstract:

The side wear protection according to the invention and for the roller of a roller press consists of several side wear protection element surrounding the roller edge. According to the invention the side wear protection elements have a base body consisting of an elastic, ductile material. Furthermore, the base body has a threaded bolt on the side of the base body directed toward the roller axis.

Hard bodies are preferably fastened on the cover side and on the front side of the base body. The hard bodies are preferably manufactured from hard metal or from a very firm iron alloy (IFW), for example FeCrMoVC.

The volume of the required hard metal can be advantageously significantly reduced by the invention, which is equivalent to a distinct lowering of the expenses. Fitting problems during the incorporation of the hard bodies such as in the prior art are not to be feared. Also, the dismounting of the side wear protection is possible without problems by loosening the screw connection and the previously necessary, expensive heating of the adhesive connection can be eliminated. The holding function of the side wear protection elements is advantageously ensured by the base body consisting of elastic material, which considerably reduces the danger of breakage.

Side Wear Protection for the Roller of a Roller Press

The invention relates to the side wear protection for rollers of a roller press and to a roller of a roller press comprising this side wear protection.

Roller presses, also called high-pressure grinding rolls, comprise two rollers with the same diameter between which the material to be comminuted is introduced and forms a material bed there. A compacting takes place by the opposite rotation of the rollers and the high pressure on the material between the rollers.

The surfaces of the rollers are exposed to a high wear. For this reason protective wear layers are used on the roller surface. For example, EP 0443 195 A1 suggests applying nubs of hard metal by welding on the roller surface. Another solution shown in DE 10 2010 924 221 consists in applying a bandage on the roller of a roller press consisting of an iron alloy with a high chromium content. The bandage is constructed in a profiled manner on the outside to improve the wear protection. Lastly, among others it is known to introduce cylinder bodies into the surface of the roller from DE 4132 474 A1, among others.

The lateral closure of the wear protection seems problematic. The radial pressure forces as well as axial forces must be received there. The wear protection should also comprise the outer areas of the front sides of the rollers since laterally exiting material leads to wear there.

EP 1 684 907 B1 suggests forming a front surface steel shielding in the area of the rotating cylinder edge consisting of a plurality of prefabricated hard bodies arranged adjacent to each other in a circle. The hard bodies are preferably shaped like a hammerhead and fastened, in particular adhered in radial grooves. This front surface steel shielding has the disadvantage that the hard bodies can break. In addition, the fastening by adhesion or soldering cannot be readily separated and

therefore a repair of the roller is not possible or is possible only with great difficulty. Last but not least, the great manufacturing tolerances in structural components like hard metal result in large adhesive gaps or in significant problems in the assembly when the hard bodies have an oversize. The large adhesive gaps are problematic since no reliable adhesion is possible and the hard bodies can fall out of the roller surface during operation. In addition, a large amount of adhesive must be used, which is disadvantageous for the large adhesive slot.

Also, a special adhesive is required, which is disadvantageous for the adhesion of large adhesive gaps. Excessively large hard bodies result, in addition to the problems during assembly and the associated expenses, in the risk that during the assembly fissures are produced in the hard metal bodies which can result in a subsequent failure. Last but not least, the use of hard metal entails very high expenses.

The present invention has the problem of suggesting a side wear protection for the roller of a roller press that has a long service life and makes possible a simple and rapid replacement.

The roller in accordance with the invention for a roller press with a side wear protection consists of several side wear protection elements surrounding the roller edge. According to the invention the side wear protection elements comprise a base body of an elastic, ductile material. Furthermore, the base body comprises a threaded bolt on the base body side directed toward the roller axis.

In the following, in order to simplify the description a definition of the sides of the base body and of the side wear protection element is presented. In the assembled state the side of the base body projects from that of the threaded bolt and is directed toward the central point of the roller (that is, the contact surface with the roller) is the base side. The side opposite this side, that forms the jacket surface of the roller, is designated as the cover side. The side of the base body which forms the front side in the assembled state is the front side and the side opposite the front side, that is adjacent to the steel screen shielding, is the back side. The remaining sides bordering on the adjacent side wear protection elements are designated as ring sides.

In one embodiment the base body has the shape of a parallelepiped. Alternatively, ring sides (the sides of the base body that border on other side wear protection elements) or also on the steel screen shielding of the roller can be designed in such a manner that a positive locking is formed with the adjacent side wear protection elements and the steel screen shielding.

In an alternative embodiment the base body is cylindrical with a round base surface. This base surface is preferably flattened on one side as a support for fastening the hard bodies.

In another embodiment the side of the base body (the back side) directed toward the steel screen shielding is convexly curved, that is, to the outside and is preferably designed to be semicircular. The steel screen shielding is correspondingly designed to be concave. In this manner the mechanical stability of the side wear protection can be advantageously increased.

In another embodiment hard bodies are fastened on the cover side and on the front side of the base body. The hard bodies are preferably manufactured from hard metal or a very firm iron alloy (I FW), for example FeCrMoVC.

In an alternative embodiment an L-shaped hard body is provided which covers the cover side and the front side of the base body. Therefore, advantageously only one hard body must be fastened on the base body and the roller edge is protected over its entire circumference.

In another embodiment the L-shaped hard body has a base form which is not rotationally symmetric, for example triangular, and the steel screen shielding of the roller comprises support surfaces for the hard body in this area. Therefore, a protection against torsion for the base body and therefore also for the side wear protection element is advantageously ensured.

In another embodiment the base body is surrounded by the steel screen shielding in such a manner that the base body is axially fixed and therefore can advantageously receive transverse forces, in particular in the axial direction away from the roller. For example, the base body can be constructed to be round for this and the receptacle in the steel screen shielding surrounds the round base body by more than 180 °C.

The hard bodies are preferably soldered on. Alternatively, there is also the possibility of adhering them on or of introducing them with casting technology. Even connections by pressing, screwing and by other mechanical connections are possible. In addition, thermal or other coatings of the base closure body are also conceivable.

The volume of the required hard metal can be advantageously significantly reduced by the invention, which is equivalent to a distinct lowering of the expenses. Fitting

problems during the incorporation of the hard bodies such as in the prior art are not to be feared. Also, the dismounting of the side wear protection is possible without problems by loosening the screw connection and the previously necessary, expensive heating of the adhesive connection can be eliminated. The holding function of the side wear protection elements is advantageously ensured by the base body consisting of elastic material, which considerably reduces the danger of breakage.

Another positive effect is the fact that the bathtub wear, that is, a greater wear that is conditioned by wear in the direction of the roller middle and which leads to a reduced radius is reduced by the lesser use of hard metal in the edge area of the roller. In this manner the required grinding volume for eliminating the bathtub-shaped wear is advantageously reduced.

Tensioning pins are preferably arranged between the side wear protection element and the cylinder edge. The tensioning pins receive axial or also tangential forces. To this end the sides of the side wear protection elements directed towards the roller axis comprise receptacles for the tensioning pins or for the tensioning pins themselves. It is especially preferred to arrange two tensioning pins in the area of the ring sides for each side wear protection element. Axial and also tangential forces acting on the side wear protection can advantageously be received by the tensioning pins. The resilient possibilities of tolerances between the support surfaces conditioned by the construction type are advantageously balanced out.

In an alternative embodiment the threaded bolt is stepped, that is, in the vicinity of the base body threaded bolt has a force receiving area with a distinctly greater diameter. The thickened area of the threaded bolt, which borders on the base body is also designated as a collar. The collar is surrounded in the assembled state by a receiving area of the roller edge, as a result of which the axial and tangential forces

are advantageously received. The collar of the threaded bolt and the receiving area of the collar in the roller edge preferably form a fit. The slot dimensions of the side wear protection can advantageously be distinctly reduced by the elastic suspension by threaded bolts.

Elastic, ductile steel types, especially annealing steels, fine-grain construction steels or resilient steels are especially preferred. Alternatively, even other highly refractory, ductile metals, e.g. duraluminum can be used.

Furthermore, the support of the side wear protection element on the roller edge is preferably a linear support in the axial direction of the roller. The linear receiving achieves a statically determined support and can advantageously prevent a tipping of the side wear protection elements.

The seating of a body on two surfaces with different angles to one another is very difficult and complex to produce from the standpoint of manufacturing technology for the case that the body should also be seated over the entire surface on these surfaces. Round geometries are advantageous which then form a linear contact with the standing surfaces there bent in such a manner and are significantly simpler to produce.

The roller of the invention for a roller press comprises at least one previously described side wear protection element.

The threaded bolt of the side wear protection element runs through the roller edge and is screwed. The screwing of the threaded bolt has a pre-tensioning force in a radial direction in an especially preferred manner.

Furthermore, an intermediate element is preferably arranged between the side wear protection element and the roller edge. The threaded bolt or a tensioning pin is preferably run through the intermediate element or the latter is fixed elsewhere in

an axial or tangential direction so that a slipping is prevented. The height (that is, the radius of the roller) of the side wear protection elements can be adjusted by the selection of the thickness of the intermediate elements. An adjustment of wear can preferably take place by the adjustment in height and the subsequent grinding of the side wear protection elements for a wear fit that was necessary according to the prior art can be eliminated. In this manner even the replacement of a single side wear protection element is significantly facilitated in an advantageous manner since its height can be adjusted by the intermediate elements and a grinding of the hard metal body for adapting the height is not necessary. This advantage also occurs when using new sides - wear elements, so that their height can be adapted without grinding by the intermediate elements during assembly.

Two exemplary embodiments of the invention are explained in the following using the figures. In the figures:

- Figure 1 Shows different views of a side wear protection element according to the invention,
- Figure 2 Shows a view of a roller edge with side wear protection elements according to the invention and in accordance with figure 1,
- Figure 3 Shows another view of the roller edge from figure 2,
- Figure 4 Shows a side view of the roller edge from figure 2,
- Figure 5 Shows two views of an alternative embodiment of a side wear protection element,
- Figure 6 Shows a side view of a roller edge with side wear protection elements according to figure 5,
- Figure 7 Shows an alternative embodiment of a wear protection element, and
- Figure 8 Shows a roller with wear protection elements according to figure

7.

Figure 1 shows different views of a side wear protection element 1 according to the invention. It comprises a parallelepipedic, elastic base body 11 manufactured from elastically ductile steel. The base body 11 has a threaded bolt 13.

In the assembled state the side of the base body 11, from which the threaded bolt 13 projects, is directed toward the center of the roller, that is, the contact surface with the roller. This side is designated here as the base side. The side opposite this side, which forms the jacket surface of the roller, is designated as the cover side. The side of the base body 11 which side forms the front side of the roller in the assembled state is the front side and the side opposite the front side and which borders on the steel screen shielding of the roller is the back side. The remaining sides, which border on the adjacent side wear protection elements are designated as ring sides.

Hard bodies 12 are soldered on the cover side and front side of the base body 11. The hard bodies 11 consist of hard metal or a very firm iron alloy (IFW). The base side comprises two semicircular recesses 15 in the area of the ring sides which serve as receptacle for tensioning pins 2. The semicircles are arranged in such a manner here that two adjacent side wear protection elements 1 form a circular recess into which a round tensioning pin can be inserted. In addition, the base side comprises two circular linear supports 14 aligned parallel to the ring sides. As a consequence the linear supports 14 are aligned with the two differently inclined planes.

Figures 2 to 4 shows a side wear protection elements 1 in the state in which they are incorporated in a roller 4. The threaded bolt 13 is run through the roller edge 41 here and fastened with a screw nut 5. On the back side the side wear protection

element 1 borders on the steel screen shielding 42 of the roller 4. The back side of the side wear protection element 1 has a circular arch in the area of each of the ring sides. Therefore, the distance from the front side and the back side in the middle area is smaller than in the area of the ring sides. The side of the steel screen shielding 42 bordering on the side wear protection elements 1 comprises semicircular recesses which receive the circular arches of the side wear protection elements 1. The different bore shapes for receiving the side - closure elements lie in the grid geometry of the steel screen shielding.

In this manner a tothing is formed between the side wear protection elements 1 and the steel screen shielding 42 and avoids groove wear, which offers additional stability for the side wear protection. A replaceable intermediate element 3 is arranged between the base body 11 and the roller edge 41 which element is used for the adjusting of the height (incorporation of different thicknesses for the height adjustment) of the side wear protection elements. The intermediate elements 3 surround the tensioning pins 2 and in addition lie in a recess of the roller edge 41 and are therefore protected against falling out. The tensioning casings 2 are seated in through bores and can therefore be adapted to the different thicknesses of the intermediate elements 3 or optionally be replaced by new ones by driving them in and out.

The figures 5 and 6 show an alternative embodiment of the side wear protection of the invention. The axial and tangential forces are transferred here via a collar 16 of the threaded bolt 13. The base body 11 is cylindrically constructed and therefore has simple geometries (helical shape) which can be manufactured in a simple manner. The receptacle for the collar 44 is a cylindrical receptacle with a level support surface lying at a right angle to the helical axis.

The bore in the roller edge 41 for receiving the threaded bolt 13 has a corresponding receptacle 44 for the collar 16. The arch of the back side of the side wear protection element 1 is located in the middle in this embodiment relative to the back side. The intermediate element 3 surrounds the threaded bolt 13 here and is therefore secured in its position.

Figure 7 shows an alternative embodiment of a side wear protection element 1. The latter comprises a one-part hard body 12. The latter is constructed in an L shape and forms the cover side and the front side of the side wear protection element 1. The elastic base body 11 is cylindrical with a circular base surface, wherein the front side of the base body 11 is constructed to be flattened and therefore forms a support for the fastening of the hard body 12.

Figure 8 shows a roller 4 with side wear protection elements 1 according to figure 7. The steel screen shielding 42 of the roller 4 comprises arc-shaped recesses 45 for the base body 11 of the side wear protection element 1 according to figure 7. This arc-shaped receptacle 45 surrounds the base body 13 (of the side wear protection element 1 according to figure 7) by more than 180° and therefore forms an axial fixing of the base body 13. Contact surfaces 46 for the hard body 12 are arranged above the recesses 45 and form a protection against torsion for the hard body 12 by their position. The side wear protection elements 1 with the threaded bolt 13 are also run through the roller edge 41 here and screwed with a screwed nut 5 and intermediate elements 3 are provided.

List of reference numerals:

- 1 side wear protection element
- 11 base body
- 12 hard body
- 13 threaded bolt
- 14 linear support
- 15 receptacle tensioning pin
- 16 grading
- 2 tensioning pin
- 3 intermediate element
- 4 roller
- 41 roller edge
- 42 steel screen shielding
- 43 arch
- 44 receptacle collar/grading
- 45 receptacle base body
- 46 contact surface
- 5 screwed nut

Claims:

1. A roller of a roller press comprising a side wear protection element with a base body of a ductile metal with a threaded bolt, wherein the threaded bolt of the side wear protection element is directed toward a roller axis, run through a roller edge of the roller and are screwed.
2. The roller of a roller press according to Claim 1, wherein the base body of the side wear protection element has a parallelepipedic shape or is cylindrical with a round base surface which is flattened on one side.
3. The roller of a roller press according to any one of claims 1 or 2, wherein the side of the base body of the side wear protection element directed toward a steel screen shielding of the roller comprises at least one arch, which is a concave arch or has a parallelepipedic shape.
4. The roller of a roller press according to any one of claims 1 to 3, wherein hard bodies are fastened on the sides of the base body which form the jacket surface and the front side of the roller in an assembled state.
5. The roller of a roller press according to Claim 4, wherein an L-shaped hard body is fastened which extends from the jacket surface to the front side of the roller and therefore covers the roller edge.
6. The roller of a roller press according to Claim 4 or 5, wherein the hard bodies consist of FeCrMoVC .
7. The roller of a roller press according to any one of Claims 4 to 6, wherein the hard bodies are soldered on the base body.

8. The roller of a roller press according to any one of claims 1 to 7, wherein receptacles for tensioning pins or tensioning pins are arranged on the side of the base body of the side wear protection element and are directed toward the roller edge .
9. The roller of a roller press according to any one of claims 1 to 8, wherein the threaded bolt is stepped and has a distinctly greater diameter starting from the base body.
10. The roller of a roller press according to any one of claims 1 to 9, wherein the ductile metal is an elastic, ductile steel.
11. The roller of a roller press according to any one of claims 1 to 10, wherein the support of the base body on the roller is a linear support in the axial direction of the roller.
12. The roller according to any one of claims 1 to 11, wherein the height of the side wear protection elements is adjusted by the selection of the thickness of intermediate elements which arranged between the side wear protection elements and the roller edge.
13. The roller according to any one of claims 1 to 12, wherein the threaded bolt of the side wear protection element is run through a roller edge of the roller and is screwed there, wherein the screwing has a pre-tension.
14. The roller according to any one of claims 1 to 13, wherein the base body is axially fixed in the steel screen shielding and can therefore receive transverse forces.
15. A roller press comprising a roller according to any one of claims 1 to 14.

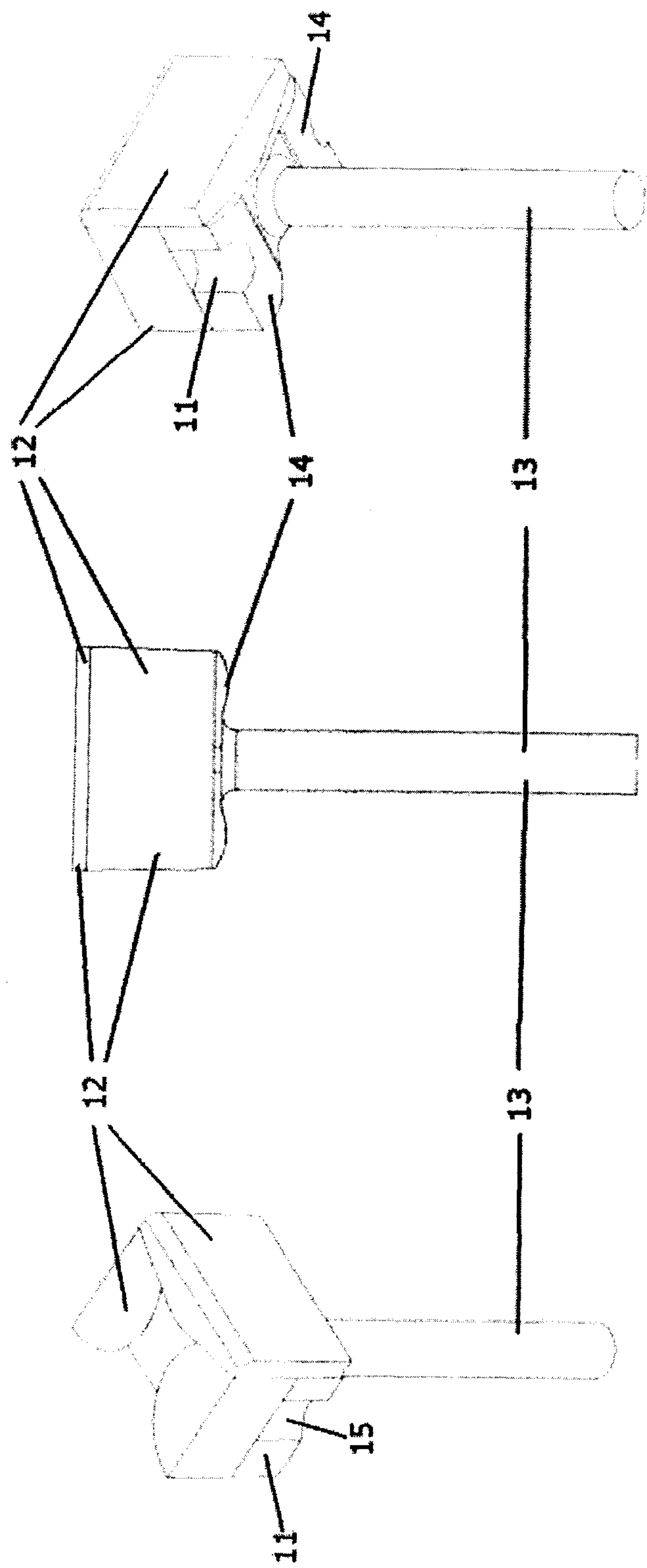

Figure 1

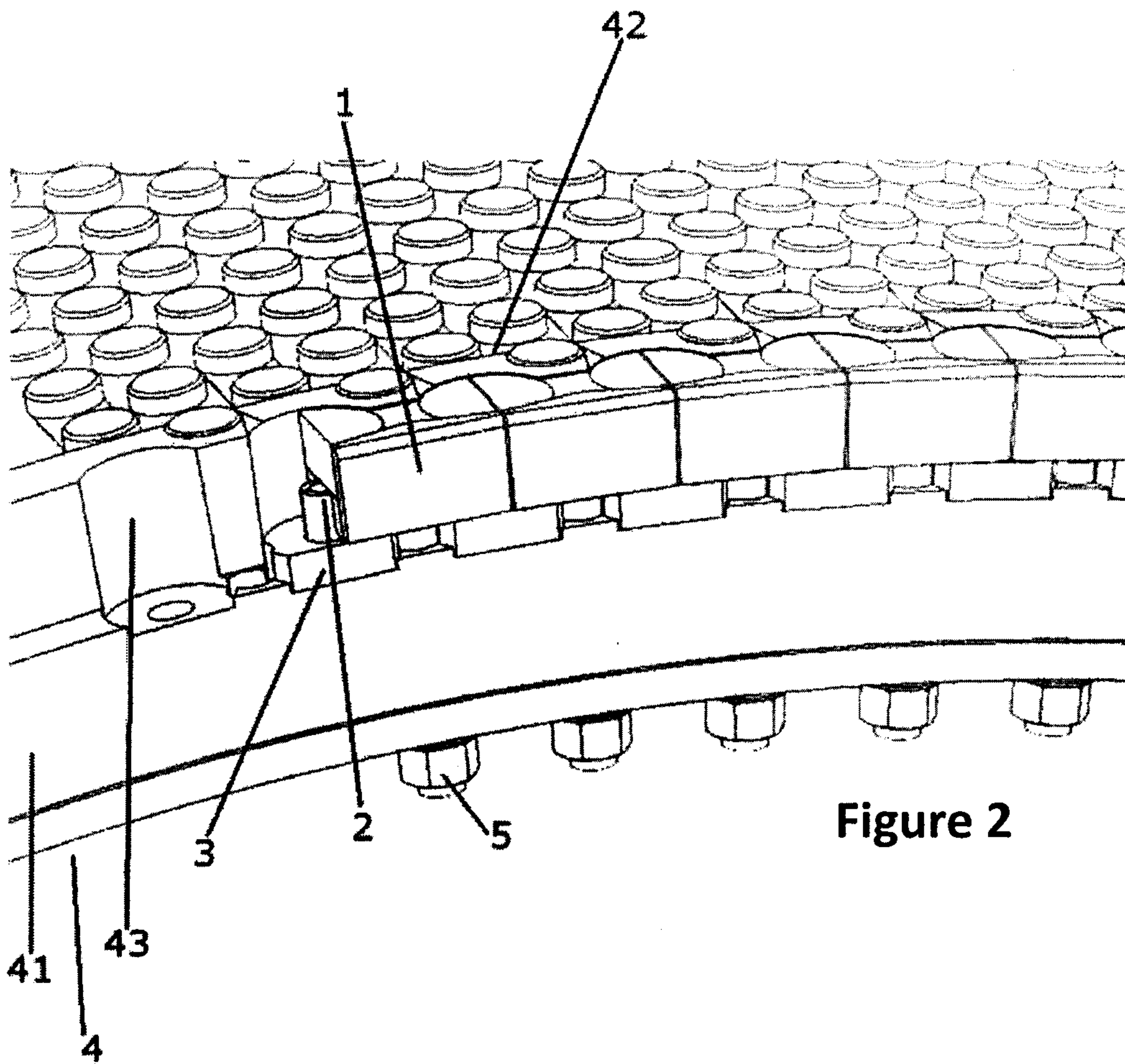
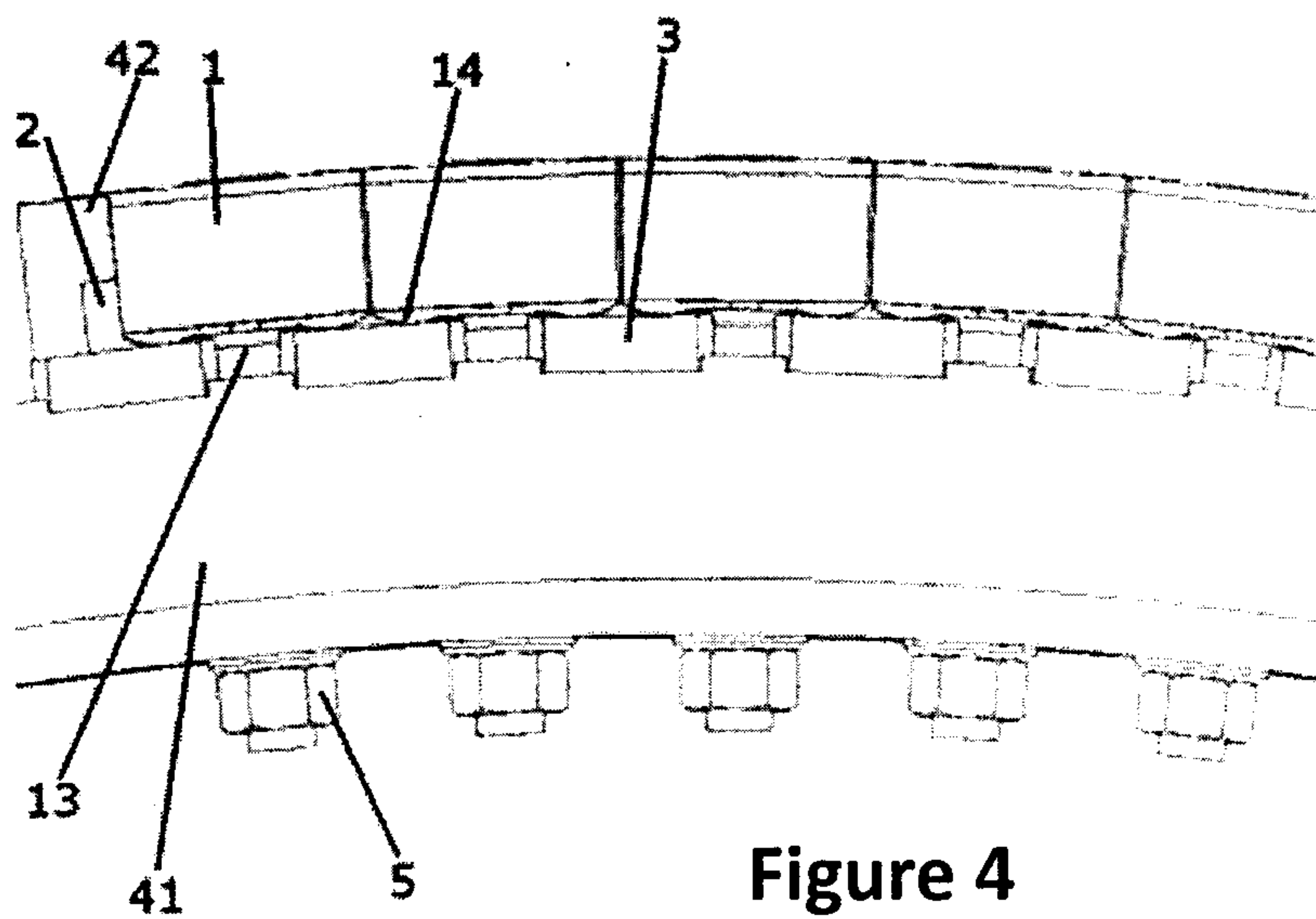
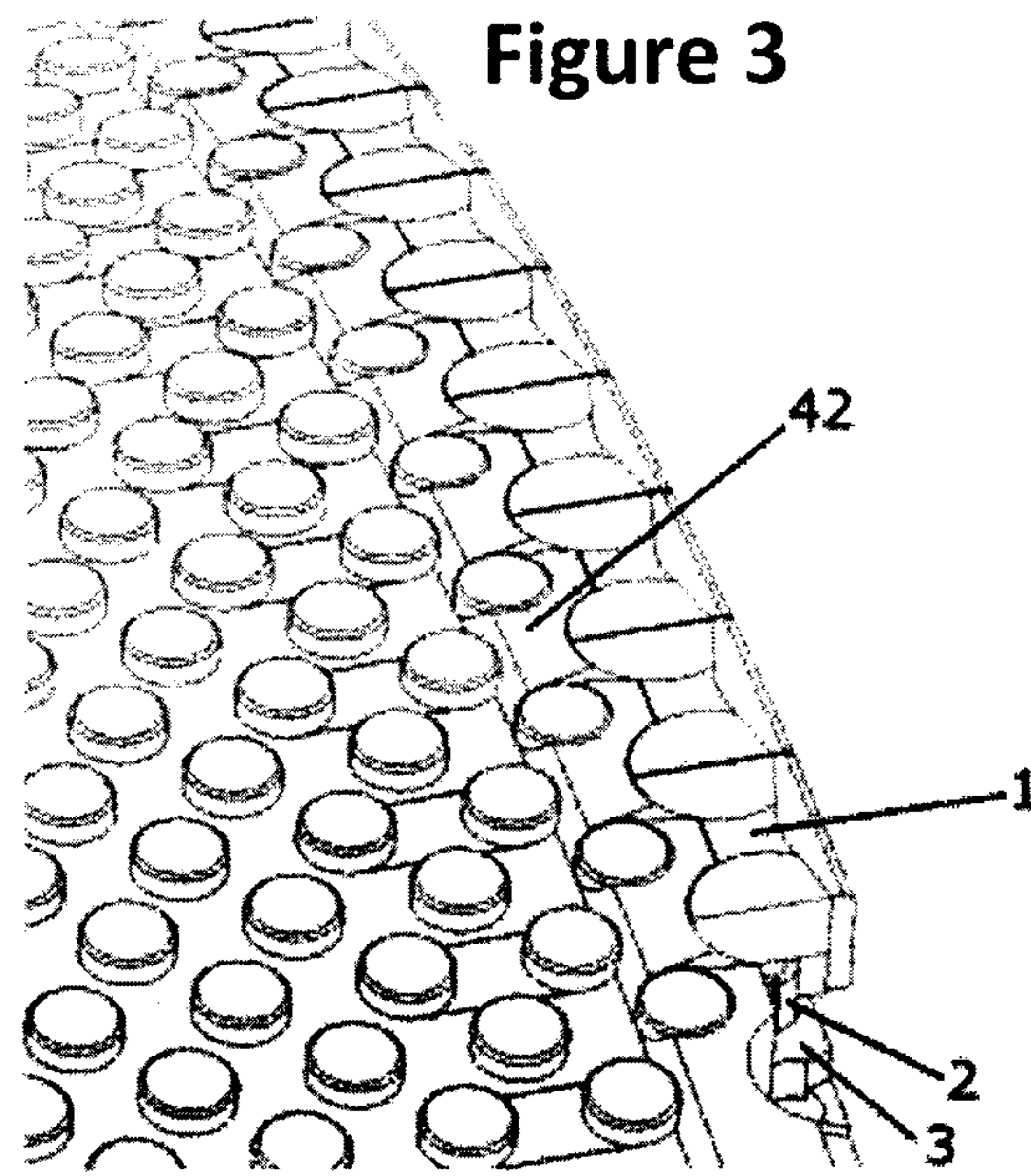

Figure 2



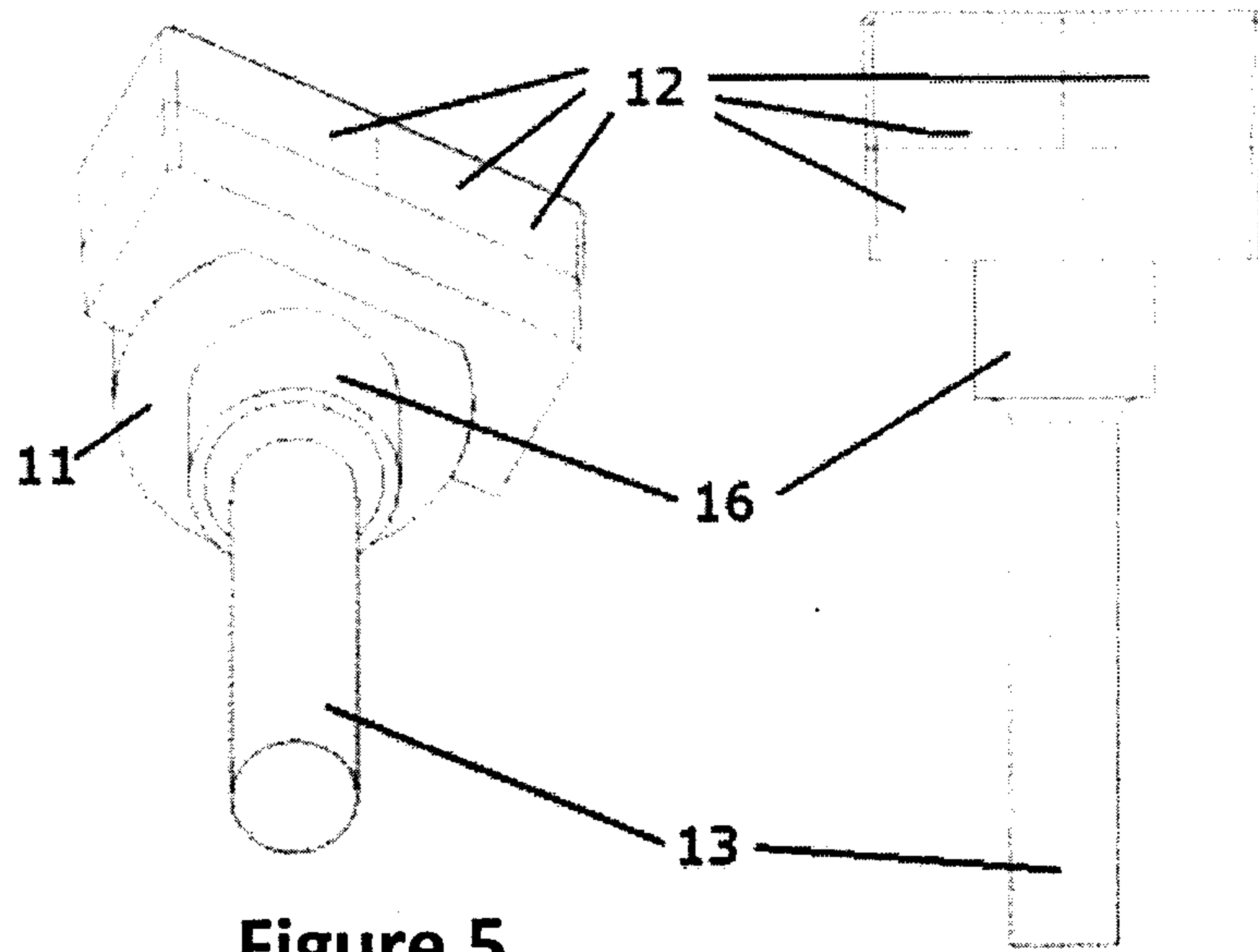

Figure 5

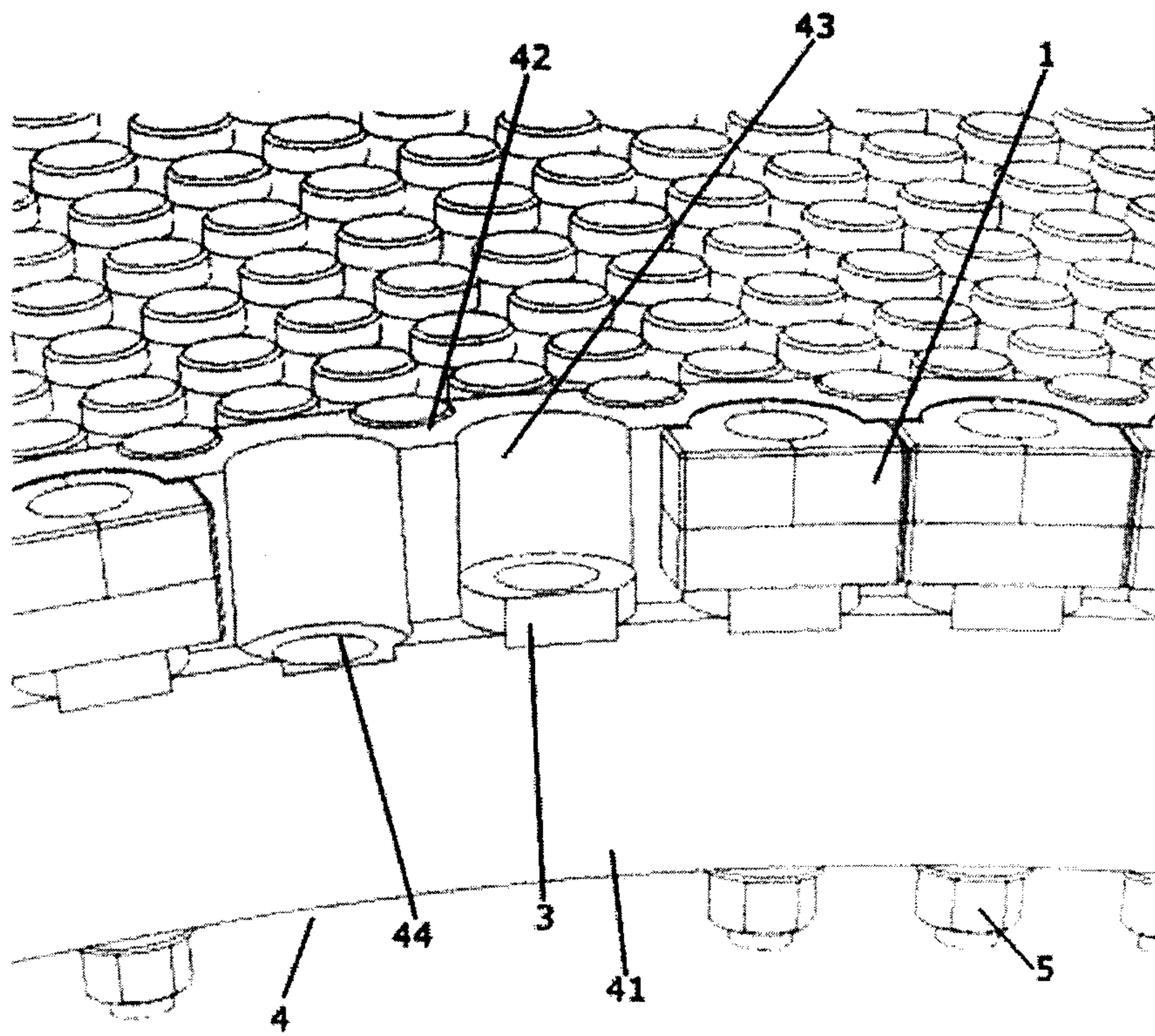

Figure 6

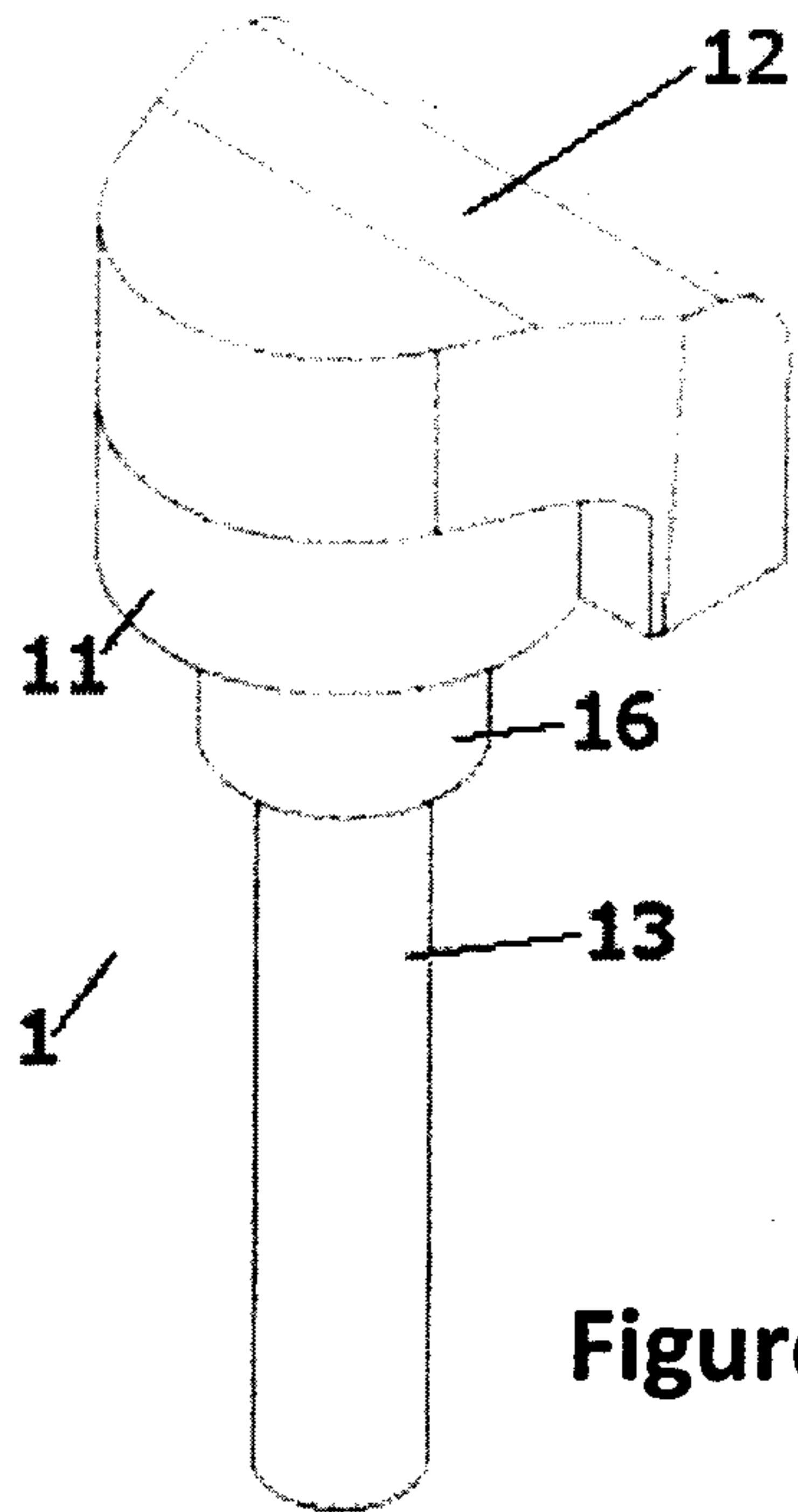

Figure 7

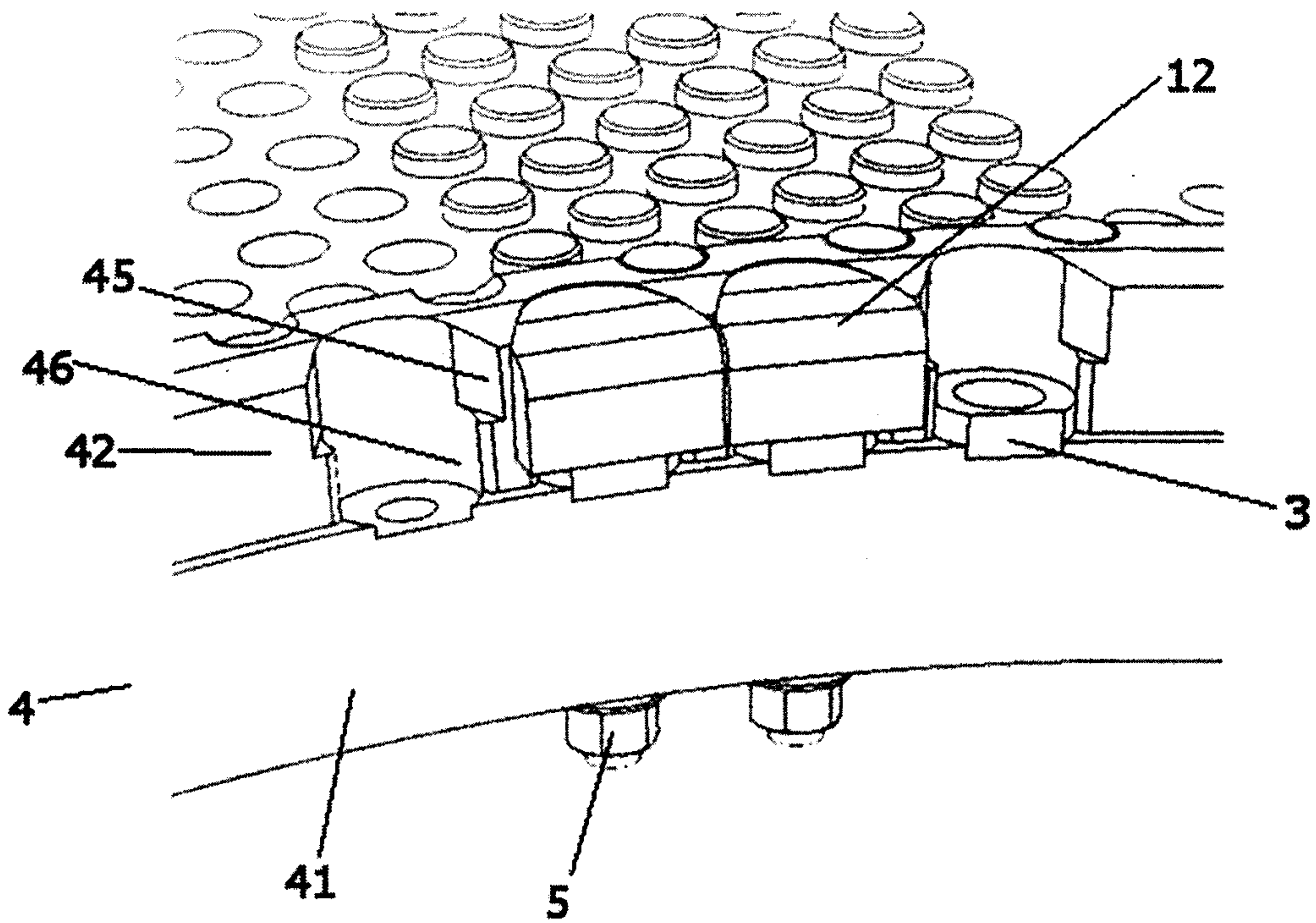

Figure 8

