

1593769

- (21) Application No. 52649/77 (22) Filed 19 Dec. 1977 (19)
- (31) Convention Application No. 778 813 (32) Filed 17 March 1977 in
- (33) United States of America (US)
- (44) Complete Specification published 22 July 1981
- (51) INT. CL.<sup>3</sup> H04R 1/30
- (52) Index at acceptance  
H4J 30F 31H EF



(54) HORN LOUDSPEAKER

(71) We, AMERICAN TRADING AND PRODUCTION CORPORATION, a Corporation organised and existing under the laws of the State of Maryland, United States of America, of One North Charles Street, Baltimore, Maryland, United States of America, do hereby declare the invention, for which we pray that a patent may be granted to us, and the method by which it is to be performed, to be particularly described in and by the following statement:—

This invention is directed to a horn loudspeaker, and in particular to a horn loudspeaker having an integrated sound chamber and horn assembly formed, in an exemplified embodiment, of two die castings, the horn assembly being folded into a structurally curved, but non-acoustically interfering, expanding horn. The horn loudspeaker is suitable for miniaturisation.

While specific types of signalling devices utilized in life safety systems, such as fire alarms, burglar alarms, etc., have taken on various forms, horn loudspeakers capable of producing voice information and/or signalling information, are preferred. Moreover, where size is not determinative, horn loudspeakers are often selected to replace cone loudspeakers, mechanical sounding devices and other vibrating and signalling devices. Cone loudspeakers do not provide a sufficiently loud sound signalling output, are subject to fatigue, have a shorter useful life than a horn loudspeaker when operated under similar conditions, and are not satisfactorily resistant to environmental elements. Mechanical sound signalling output devices are not capable of providing voice information. However, due to the excessive size, manufacturing difficulties, installation difficulties and loss of performance efficiency, when conventional horn loudspeakers are miniaturized, horn loudspeakers have been found to be unacceptable for use in a four-inch electrical box of the type typically utilized to house conventional life safety system signalling devices. Accordingly, a horn loudspeaker that is acoustically efficient, element resistant, temperature rated, easy to manufacture and install, and is sufficiently small to permit

same to be installed in what is customarily referred to as a four-inch electrical box, is desired.

It is an object of the instant invention to provide a simple to manufacture horn loudspeaker having low distortion, environment resistance and high efficiency and suitable for miniaturization.

Another object of the instant invention at least in a preferred form is to provide a miniaturization horn loudspeaker having an integrated sound chamber and horn assembly, formed of two die castings, wherein the horn assembly is folded into a non-acoustically interfering expanding horn.

Still another object of the instant invention in a preferred form is to provide a miniaturized horn loudspeaker communication and signalling system that can readily replace a mechanical and/or vibratory signalling device disposed in a four-inch electrical box.

Still a further object of the instant invention in a preferred form is to provide a miniaturized horn loudspeaker for producing voice information or signalling information, or both voice information and signalling information, concurrently.

Still a further object of the instant invention in a preferred form is to provide an improved miniaturized horn loudspeaker for use in alarm signalling systems, intercom systems, paging systems and the like.

Accordingly the present invention provides a horn loudspeaker having a sound chamber and horn assembly comprising a sound chamber housing a diaphragm and moving coil loudspeaker driver assembly, said sound chamber having a sound opening having a predetermined acoustic orientation, a first horn stage having a first opening acoustically coupled to said sound opening, said first horn stage having a flare rate that expands as said first horn stage extends away from said first opening to define a further opening, said first stage having an acoustical orientation, at said further opening, that is disposed at least 90° from the predetermined acoustic orientation of said sound opening, and an output horn stage acoustically coupled at a first end thereof to the further

opening of said first horn stage, said output horn stage having a flare rate that expands as the output stage extends away from said first stage to define a horn output at the other end of said output horn stage, said output horn stage having a continuously changing acoustical orientation along the lengthwise extent thereof, so that the acoustical orientation at said horn output is at least 90° disposed with respect to the acoustical orientation of said output horn stage at the acoustical junction between said first horn stage and said output horn stage so that the output of said output horn stage is oriented in the same direction as the predetermined acoustical orientation of said sound opening.

For a fuller understanding of the invention, reference is had to the following description of one embodiment thereof, given by way of example only and taken in connection with the accompanying drawings, in which:

Fig. 1 is an elevational view of a four-inch type electrical box housing a miniaturized horn loudspeaker;

Fig. 2 is a sectional view taken along line 2—2 of Fig. 1;

Fig. 3 is a sectional view taken along line 3—3 of Fig. 2;

Fig. 4 is a sectional view taken along line 4—4 of Fig. 3;

Fig. 5 is a plan view of a die casting constructed in accordance with the preferred embodiment of the instant invention;

Fig. 6 is a plan view of a further die casting constructed in accordance with the preferred embodiment of the present invention; and

Fig. 7 is a perspective view of the miniaturized horn loudspeaker assembly of the instant invention.

As is illustrated in Figs. 1 through 7, the miniaturized horn loudspeaker is particularly characterized by forming a highly efficient, water resistant, easy to manufacture and install, miniaturized horn loudspeaker using two die castings. As is discussed in greater detail below, both die casting members, in principle, form a horn by folding the horn into a bent configuration that provides substantially the same acoustical efficiency as a conventional elongate straight horn in a considerably reduced space. Accordingly, as utilized herein, the term "acoustical orientation" defines what is ordinarily referred to as the axial direction of a conventional horn. Also, the term "expanding flare rate", as utilized herein, refers to the substantially exponential horn characteristic of the respective horn stages, when the cross-sectional area of each horn stage increases with the acoustical orientation of the horn.

Reference is made to Figs. 1 and 2 wherein a four-inch electrical box, generally indicated as 10a and an electrical box cover 10b, are depicted. Such four-inch electrical boxes

have been utilized indoors and outdoors to house mechanical and vibrating sound signalling and voice communication devices. It is noted that four-inch electrical boxes of the type described herein are well known in the art and, in fact, have an outside dimension that is four and one-quarter inches square, and with the cover therefor, a usual depth of less than four inches. However, it is also noted that the interior of the four-inch electrical box provides a space for a sound signalling device such as the miniaturized loudspeaker of the instant invention, that is slightly less than four-inches square and with the cover thereon, three and one-half inches deep.

Reference is now made to Figs. 2 through 7, wherein a miniaturized horn loudspeaker, constructed in accordance with a preferred embodiment of the instant invention, is depicted. The miniaturized loudspeaker is characterized by a small sized, simple to install, element resistant, integrated sound chamber and horn assembly formed from two die castings, a sound chamber die casting 12, particularly illustrated in Fig. 5, and an output horn die casting 14, particularly illustrated in Fig. 6.

The sound chamber die casting 12, is comprised of a sound chamber, generally indicated at 15, and a first half-wall 16. As is best illustrated in Fig. 7, the sound chamber is formed by a cylindrical wall 17, a diaphragm support wall 18 and a sound opening 20. The sound chamber 15 is adapted to receive a diaphragm assembly and loudspeaker moving coil drive assembly in a conventional manner, to be discussed in greater detail below.

The first half-wall 16 shaped to define a first loudspeaker horn stage having a continuously increasing expansion rate over the length thereof, as the half-wall extends from the sound opening 20 to projecting end wall 21. Additionally, outer projecting wall 22 and inner projecting wall 23 extend from the sound opening 20 in the second chamber, to projecting end wall 21. The respective projecting walls 22 and 23 and end wall 21 are raised from the surface 25 of die casting 12, and as explained in greater detail below, when disposed in juxtaposed relationship with a second half-wall formed in output horn die casting 14, define a non-acoustically interfering expanding first horn stage along the entire acoustical dimension defined thereby. Also, as is detailed below, the surface 25 of the sound chamber die casting 12 further defines, among other openings, a strain relief opening 24, which opening permits a strain relief to secure all of the wires in the loudspeaker and avoid damage to the wires during installation of the horn loudspeaker assembly in a four-inch electrical box 10a.

An elongate terminal through hole, generally indicated at 70, is formed in the sound chamber die casting to receive a round insulated terminal assembly 71 (illustrated in Fig. 7) for coupling the voice coil leads to the loudspeaker drive circuitry. The terminal through hole is defined by a raised annular wall 72 on both surfaces of the die casting and an inward step 74 positioned in the through hole for anchoring the terminal assembly 71 therein.

The output horn die casting 14, as is best illustrated in Figs. 2 and 3, defines curved output horn stage 26, which stage forms an increasing expansion rate over the entire acoustical dimension thereof. The output horn stage 26 is formed by horn walls 27a, 27b, 27c and 27d, which walls, as illustrated in Figs. 2 and 3, define a continuously curved, acoustically non-interfering output horn stage.

Output horn die casting 14 further includes a second half-wall 30, defined by outer recessed wall 31, inner recessed wall 32 and recessed end wall 33. When the output horn die casting 14 is secured in juxtaposed relationship to the sound chamber die casting 12, the respective first horn stage half-wall 16 and the output horn stage half-wall 30 form a structurally curved first horn stage. As is illustrated in Fig. 6, recessed walls 31 and 32 define a continually increasing flare rate along the acoustical dimension of the second half-wall 30, as second half-wall 30 extends from sound chamber 15 to the output horn stage 26. An acoustical compensating ridge 34 is disposed at the position that the first horn stage is acoustically coupled to the output horn stage in order to reduce reflective interference at the sharp 90° turn, in the acoustical orientation defined by the acoustic coupling of the first horn stage with the output horn stage. Walls 31, 32 and 33 are recessed from meeting wall 36 in order to receive the projecting walls 22, 23 and 21 of the sound chamber die casting 12, when meeting wall 36 is placed flush with surface 25. When the sound chamber die casting 12 and output horn die casting 14 are secured together, by appropriate means, so that the projecting side walls and end wall of the sound chamber die casting are projecting into the recessed side walls and end walls of the output horn die casting, an integrated sound chamber and horn assembly, formed of two die castings, for use in four-inch electrical box 10a, is provided.

Reference is now made to Fig. 4, wherein the elements comprising the diaphragm and moving coil loudspeaker driver assembly, generally indicated as 40, particularly adapted to be disposed in the sound chamber 15, are depicted. The diaphragm consists of a molded cone 38 and "Bakelite" (Registered Trade Mark) alignment ring 42 positionally

secured against the diaphragm support wall 18 by annular top plate 41. A voice coil 43, having leads for coupling the driver voice coil to the assembly, is wrapped around an annular wall of the molded cone that is directed away from the diaphragm support wall 18 in a conventional manner. A non-magnetic, preferably plastics, positioning element 45, supports a pole cap 44 in a spaced apart relationship with top plate 41 to dispose the voice coil therebetween and dispose the pole cap 44 in abutting relationship with a magnet 47 utilized to effect driving of the loudspeaker assembly. The loudspeaker assembly further includes a magnetic pot 48, which pot is secured to the sound chamber 15, by a clamp 49 having a cylindrical wall 50 and an annular lip 51. Cylindrical wall 50 supports at least two screw receiving projections 53. The cylindrical wall 17, of the sound chamber 15, also includes screw receiving projections 54 having a threaded opening therein, for receiving clamping screws 55 inserted through projection 53 to thereby secure the magnetic driver assembly in the sound chamber and provide a water tight magnetic assembly that operates in a conventional manner. The water tight seal is effected by disposing an annular rubber gasket 52 between clamp 49 and cylindrical wall 17 so that tightening of clamping screws 55 will effect a water seal therebetween.

In order to further facilitate the assembly of the miniaturized loudspeaker and installation of same in a four-inch electrical box, the die castings are formed to provide means for readily anchoring the operative element of the loudspeaker assembly to the respective die castings to form a completed horn loudspeaker assembly. For example, a mounting assembly comprised of post 56, bracket 57 and screw 58 can be utilized to positionally secure to the sound chamber die casting a large condenser 59, as illustrated, or alternatively, if desired, a printed circuit board. As noted above, strain relief opening 24 is provided in the surface 25 of sound chamber die casting 12 for receiving a strain relief 61, which strain relief secures the wires for coupling the loudspeaker driver assembly to appropriate circuitry for energizing and activating same and prevents the wires from being damaged when the loudspeaker assembly is installed in a four-inch electrical box. Also, a variable tap line matching transformer, also referred to as a line-to-voice transformer, generally indicated as 62, is positioned by positioning posts 63, formed on output horn die casting 14, the positioning posts being provided with a threaded opening to receive a screw (not shown) and thereby securely position the line-to-voice coil transformer in the loudspeaker assembly. The positioning post can also be used for

securing a printed circuit board to the loudspeaker assembly. Also a terminal strip mounting bracket 64 is formed on the output horn die casting to support a screw terminal strip 65, for mounting optional items in the loudspeaker assembly, such as voice detection wires and the like. Additionally, a further terminal strip mounting assembly is provided on the outer surface of half-wall 16, and is formed of two mounting ribs 75 and 76, and an opening 77 for securing a further terminal strip thereto, if such a terminal strip is desired.

Sound chamber die casting 12 is provided with screw receiving openings 66a, 66b and 66c, which openings align with threaded screw receiving openings 65a, 65b and 65c in the output horn die casting, to thereby permit threaded screws (not shown) to be inserted through the respective screw receiving openings into the threaded screw receiving openings to thereby secure the respective die castings together. Additionally, U-shaped projecting elements 78, or other appropriate means, are provided, on the respective die castings for positionally referencing the loudspeaker assembly with respect to the cover for the four-inch electrical box. Holes can be provided in the die castings for receiving positioning pins in the four-inch electrical box and cover therefor, in order to further effect self-alignment of the loudspeaker assembly during installation of same in the four-inch electrical box.

Horn loudspeaker design requires that the horn have an increasing flare rate over a predetermined distance. Accordingly, the instant invention has provided a non-acoustically interfering curved horn, that provides a sufficient acoustical length to yield a highly efficient loudspeaker. The sound opening 20, in the sound chamber, is acoustically perpendicularly oriented with respect to the front surface of the electrical box and opens into the first horn stage defined by first half-wall 16 and second half-wall 30, to define a substantially U-shaped (in plan view) first horn stage. As noted above, the respective side walls continually flare away from each other to provide the first horn stage with an increasing flare rate. It is noted that a portion 28, of the first horn stage half-wall 16, is slanted inwardly in order to redirect the sound around the acoustical compensating projection 34 and into the output horn stage 26. The sound is acoustically redirected 180° through the first horn stage, and is thereafter deflected by slanted wall portion 28 around the acoustical compensating ridge into the output horn stage 26, whereby the direction of the sound is once again reoriented by 90° at the opening of the output horn stage. Thereafter the direction of the sound is again reoriented by 90° in the output horn stage so that the output of the output horn stage is

oriented in the same direction as the predetermined acoustical orientation of the sound opening. Accordingly, by utilizing two die castings, an integrated sound chamber and horn assembly, that can be utilized in a four-inch electrical box, is provided.

A miniaturized, high performing loudspeaker that permits the sounds of signalling devices of the mechanical or vibrator type and/or voice information to be efficiently produced and is manufacturable and installable with high reliability, is therefore provided. Moreover, the unique two-piece construction, whether formed by die casting both members, molding both members or utilizing any other forming technique, makes it difficult to damage the speaker assembly during the course of installation and during the useful life of the horn loudspeaker.

#### WHAT WE CLAIM IS:—

1. A horn loudspeaker having sound chamber and horn assembly comprising a sound chamber housing a diaphragm and moving coil loudspeaker driver assembly, said sound chamber having a sound opening having a predetermined acoustic orientation, a first horn stage having a first opening acoustically coupled to said sound opening, said first horn stage having a flare rate that expands as said first horn stage extends away from said first opening to define a further opening, said first stage having an acoustical orientation, at said further opening, that is disposed at least 90° from the predetermined acoustic orientation of said sound opening, and an output horn stage acoustically coupled at a first end thereof to the further opening of said first horn stage, said output horn stage having a flare rate that expands as the output stage extends away from said first stage to define a horn output at the other end of said output horn stage, said output horn stage having a continuously changing acoustical orientation along the lengthwise extent thereof, so that the acoustical orientation at said horn output is at least 90° disposed with respect to the acoustical orientation of said output horn stage at the acoustical junction between said first horn stage and said output horn stage so that the output of said output horn stage is oriented in the same direction as the predetermined acoustical orientation of said sound opening.

2. A horn loudspeaker as claimed in claim 1, wherein said first horn stage is configured to acoustically orient the further opening of said first horn stage at 180° in a first plane with respect to said predetermined acoustic orientation of said sound opening.

3. A horn loudspeaker as claimed in claim 2, wherein said acoustical junction between said further opening of said first horn stage and the output horn stage effects a further reorientation of said acoustical orien-

tation at the input of said output horn stage of 90° with respect to said further opening of said first horn stage.

5 4. A horn loudspeaker as claimed in claim 3, wherein said first stage includes acoustical compensation means disposed at a position where said further opening of said first horn stage is acoustically coupled to the  
10 input of said output horn stage and said portion of said first horn stage opposite said acoustical compensating means and said acoustical junction is inwardly directed, to  
15 direct sound into said output horn stage, said acoustical compensation means being adapted to reduce reflective interference at the acoustical junction defined thereat.

20 5. A horn loudspeaker as claimed in claim 3, wherein said sound chamber and horn assembly is comprised of first and second joined members, said first member forming said sound chamber and a half-wall for forming said first horn stage, said second member forming said output horn stage and the other half-wall of said first horn stage.

25 6. A horn loudspeaker as claimed in claim 5, wherein said first and second members are die castings.

30 7. A horn loudspeaker according to any preceding claim capable of being accommodated in a four-inch electrical box.

8. A horn loudspeaker substantially as described herein with reference to and as illustrated in the accompanying drawings.

For the Applicants:  
A. SPENCE & CO.,  
Chartered Patent Agents,  
114 Downlands Road,  
Purley,  
Surrey CR2 4JF.

FIG.1

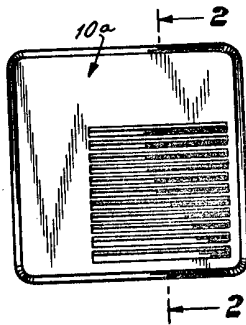

FIG.2

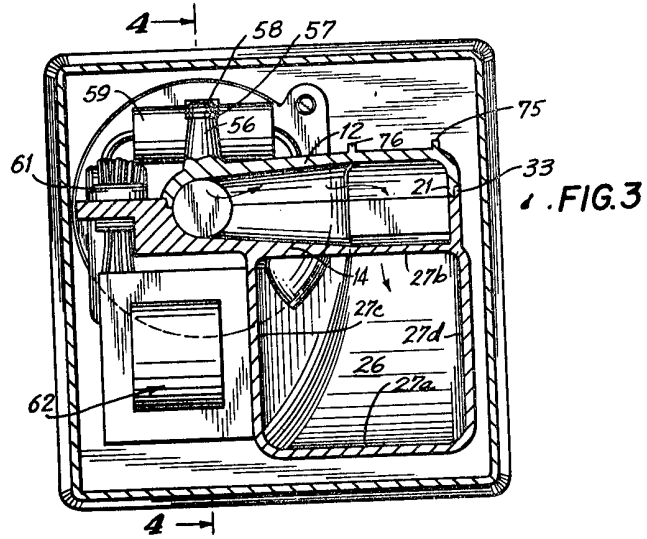
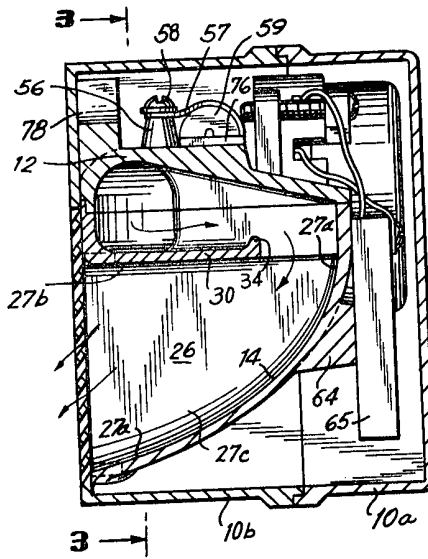

FIG.4

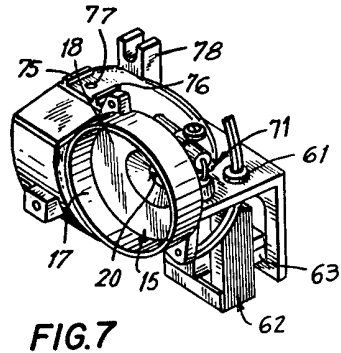
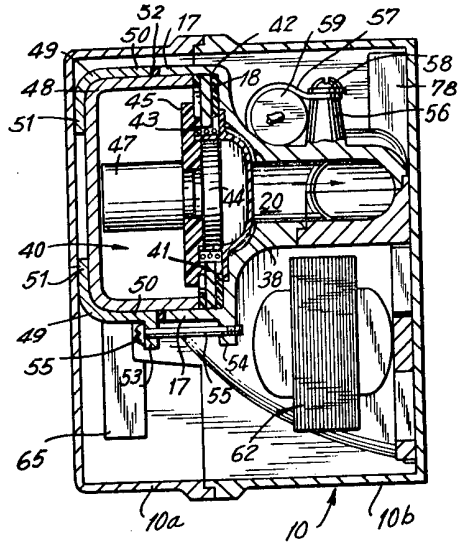

FIG.7

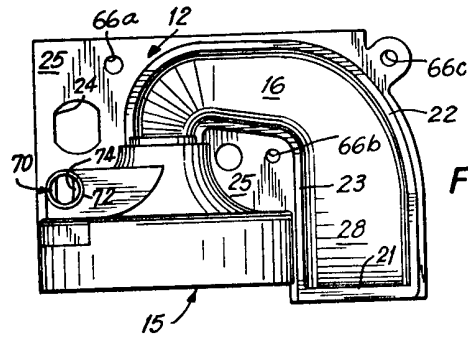

FIG.5

FIG.6

