

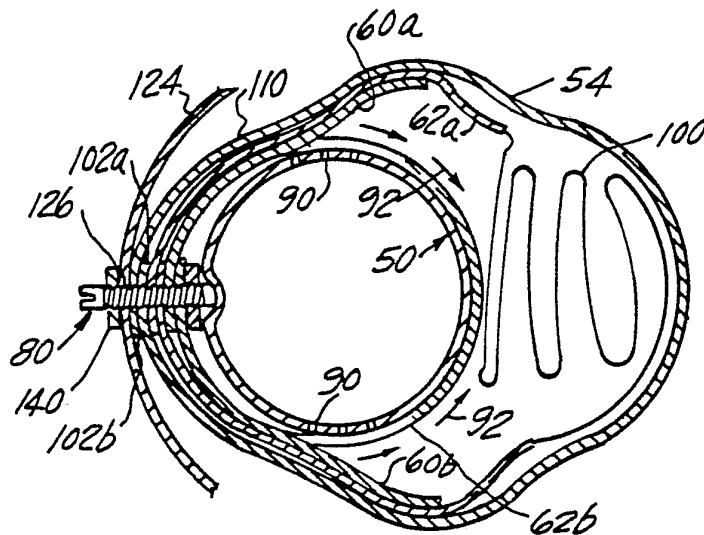

INTERNATIONAL APPLICATION PUBLISHED UNDER THE PATENT COOPERATION TREATY (PCT)

<p>(51) International Patent Classification ⁵ : B60R 21/26</p>	<p>A1</p>	<p>(11) International Publication Number: WO 91/03391 (43) International Publication Date: 21 March 1991 (21.03.91)</p>
<p>(21) International Application Number: PCT/US90/03604 (22) International Filing Date: 26 June 1990 (26.06.90) (30) Priority data: 401,216 31 August 1989 (31.08.89) US (71) Applicant: ALLIED-SIGNAL INC. [US/US]; Law Department (C.A. McNally), P.O. Box 2245R, Morristown, NJ 07962-2245 (US). (72) Inventors: BISHOP, Robert, John ; 8575 Springwood Way, Washington, MI 48093 (US). FONTECHHIO, Robert, Paul ; 658 Timberline, Rochester Hills, MI 48309 (US). GOOD, Stanley, B. ; 2810 Bluebird Lane, Richmond, MI 48062 (US). HENDRIX, Troy, Calvin ; Route 5, Box 336, Maryville, TN 37801 (US).</p>		<p>(74) Agent: ROONEY, Gerard, P.; Allied-Signal Inc., Law Department (C.A. McNally), P.O. Box 2245R, Morristown, NJ 07962-2245 (US). (81) Designated States: AT (European patent), BE (European patent), CH (European patent), DE (European patent)*, DK (European patent), ES (European patent), FR (European patent), GB (European patent), IT (European patent), JP, KR, LU (European patent), NL (European patent), SE (European patent). Published <i>With international search report.</i></p>

(54) Title: INTEGRAL RETAINER, HEAT SHIELD AND ASSEMBLY



(57) Abstract

A device (20) comprising a planar metal sheet (21; 21') having formed thereon at least a first set of opposing shaped slots (60a, b) such that upon forming the planar sheet as an open ended (122) generally cylindrical member or cylinder (28) first portions of the sheet, defined by the slots, extend away from the surface of the formed cylindrical member and form in conjunction with other surfaces of the sheet a plurality of first apertures (62a, b), and the extending first portions serving to define a heat shield for shielding a portion of an air bag (100), adapted to be secured thereabout, from hot gas generated by a gas generator (50), the device including securement means, interacting with a rearward portion of the cylindrical member and adapted for urging a gas generator (50) into forward facing portions of the cylindrical member, for securing same in place.

DESIGNATIONS OF "DE"

Until further notice, any designation of "DE" in any international application whose international filing date is prior to October 3, 1990, shall have effect in the territory of the Federal Republic of Germany with the exception of the territory of the former German Democratic Republic.

FOR THE PURPOSES OF INFORMATION ONLY

Codes used to identify States party to the PCT on the front pages of pamphlets publishing international applications under the PCT.

AT	Austria	ES	Spain	MC	Monaco
AU	Australia	FI	Finland	MG	Madagascar
BB	Barbados	FR	France	ML	Mali
BE	Belgium	GA	Gabon	MR	Mauritania
BF	Burkina Fasso	GB	United Kingdom	MW	Malawi
BG	Bulgaria	GR	Greece	NL	Netherlands
BJ	Benin	HU	Hungary	NO	Norway
BR	Brazil	IT	Italy	PL	Poland
CA	Canada	JP	Japan	RO	Romania
CF	Central African Republic	KP	Democratic People's Republic of Korea	SD	Sudan
CG	Congo	KR	Republic of Korea	SE	Sweden
CH	Switzerland	LI	Liechtenstein	SN	Senegal
CM	Cameroon	LK	Sri Lanka	SU	Soviet Union
DE	Germany	LU	Luxembourg	TD	Chad
DK	Denmark			TG	Togo
				US	United States of America

INTEGRAL RETAINER, HEAT SHIELD AND ASSEMBLY

BACKGROUND AND SUMMARY OF INVENTION

5 The present invention relates to assemblies
useful in inflatable restraint (air bag) systems and
particularly relates to a retention device for
supporting a gas generator retaining an air bag and
for shielding the air bag from the heated gases
10 produced by the gas generator.

Inflatable restraint systems are becoming the
norm for passenger protection. A rudimentary system
comprises of a crash sensor mounted to the vehicle
15 frame and an air bag assembly positioned within the
passenger compartment. Differing types of assemblies
are used for driver side restraint systems and
passenger side restraint systems. The present
invention finds specific application with a passenger
20 side air bag restraint system. These assemblies will
often include an outer reaction can into which is
received a gas generator. This can is a structurally
sound member which absorbs and retransmits the air
bag deployment forces to the vehicle. The can also
25 supports the weight of the gas inflator and an air
bag. Usually the air bag is placed into the can in
close proximity to the gas generator and a cover is
placed about the can to secure the bag in its
nondeployed or stored condition. The reaction can is
30 typically mounted to or near the dash board or
instrument panel of the vehicle. Because the

reaction can directly supports the weight of the gas generator and air bag and since it is used to transmit the deployment forces it weights is high adding to the overall vehicle weight.

5

The object of the present invention is to provide an integral air bag/gas inflator/heat shield member. A further object of the present invention is to form a one piece housing defining the retainer and
10 heat shield that is subsequently formed into a cylindrical shape. Another object of the present invention is to provide means for securing a gas generator within the housing. Another object of the present invention is to provide such a device wherein
15 the deployment reaction forces can be transmitted directly to the vehicle as opposed to a reaction can. An additional object is to use the retainer as a securement for the air bag and if the air bag includes tethers to secure the tethers to the
20 retainer.

Accordingly, the invention comprises: a retainer for use in an air bag restraint system of the type using an air bag and gas generator. The retainer
25 comprising a planar metal sheet having formed thereon at least a first set of opposing, generally U-shaped slots such that upon forming the sheet as an open ended cylinder the portions of the sheet, originally within the slots, extend away from the surface of the
30 formed cylinder and form in conjunction with other surfaces of the metal sheet, a plurality of first apertures, and define heat shield means, such as

35

wing-like projections, for shielding a portion of an air bag adapted to be secured thereabout from the hot gas generated, by a gas generator adapted to be secured therein. The invention includes securement
5 means, interacting with a rearward portion of the formed cylinder to urge a gas generator into forward portions of the cylinder, proximate the apertures, thereby securing same in place. The securement means including a plurality of bolts threadably received
10 within a holding member for guiding same into engagement with a preferably deformable wall of the gas generator. As a result of the compressive engagement of the bolts to the wall, respective depressions are created such as by the elastic
15 deformation of the wall in cooperation with each bolt, to assist in radially and axially securing the gas generator therein.

Many other objects and purposes of the invention
20 will be clear from the following detailed description of the drawings.

Brief Description of the Drawings

25

In the drawings:

FIGURE 1 illustrates a planar view of a sheet in accordance with the present invention prior to its being formed into a cylindrical shape.

30 FIGURE 2 illustrates a front plan view of a formed retainer.

FIGURE 3 is a plan end view of the device shown in FIGURE 2.

35

-4-

FIGURE 4 is a cross-sectional view through section 4-4 of FIGURE 2.

FIGURE 5 is a front sectional view of the device shown in FIGURE 2 and also illustrates the placement
5 of a gas generator therein.

FIGURE 6 is a cross-sectional view through section 6-6 of FIGURE 5.

FIGURE 7 illustrates a planar view of another embodiment of the present invention.

10 FIGURE 8 illustrates a front plan view of a retainer obtained with this alternate embodiment.

FIGURE 9 illustrates a cross-sectional view of the invention in its fully assembled configuration.

15 FIGURE 10 is an enlarged view of a portion of FIGURE 9.

FIGURE 11 is an alternate embodiment of some of the elements of FIGURE 10.

FIGURE 12 illustrates a projected view of an outer can.

20 FIGURE 13 diagrammatically illustrates an air bag usable in the present invention.

FIGURE 14 illustrates a further embodiment of the invention.

25 DETAILED DESCRIPTION OF THE DRAWINGS

With reference to the FIGURES, and in particular FIGURE 1, there is shown a planar view of an integral air bag/inflater/heat shield 20, hereinafter called
30 retainer 20 in an early stage of assembly. The retainer 20 comprises a substantially planar metal sheet 21 having formed therein two opposing U-shaped

35

slots 22a and 22b. Such slots may be sharp cornered as illustrated, curved, etc. Positioned above slot 22a are a plurality of openings 24a and positioned below slot 22b are another plurality of slots 24b.

5 The sets of openings 24a and b are fabricated in sides 26a and b of the sheet 21. The openings 24a and 24b are aligned and spaced relative to one another such that when the planar sheet 21 is rolled about itself and the sides are placed in overlapping

10 engagement as shown in FIGURES 2-4 the sets of holes 24a and b will be registered one to the other. A bolt shown diagrammatically in FIGURES 3 and 4 will extend through the registered holes 24.

The two opposing U-shaped slots 22a and b define

15 therebetween a center member 40 and ends 42a and b within the sheet 21. The distance between the holes 24a and b is chosen such that when the sheet 21 is in its rolled over configuration its diameter is slightly larger than the diameter of an associated

20 gas generator 50 (see FIGURES 5 and 6). The bolt shown in FIGURE 6 is a diagrammatic representation.

With reference to FIGURE 2, such figure illustrates a formed retainer 20, i.e., cylinder 28, with the sides 26a and b in overlapping, registered

25 alignment. The ends 42a and b have been formed into cylindrical end bands 52a and b joined at a forwardly extending location by the center member 40 which forms a partially enclosed axially extending side 54 of the cylinder 28, the overlapping sides 24a and 24b

30 forming a rear side 56 thereof.

The process of rolling over, or otherwise forming, the planar sheet 21 to achieve the

cylindrical shape shown in FIGURE 2 will cause members 60a and b of the sheet, i.e., the portion of the sheet 21 within the slots 22, to extend somewhat tangentially, through accurately outward above the
5 main cylindrical shape of the formed retainer 20. The relative positioning of the members 60a and b to the end bands 52a and b is more clearly shown in FIGURES 3 and 4. In this configuration the members 60a and b form wing-like projections extending from
10 the general cylindrical shape of the retainer 20. In this configuration, the elevated orientation of these members 60a and b form, relative to the end bands and sides, a plurality of openings 62a and b.

Reference is briefly made to FIGURES 8 and 9
15 which illustrate an alternate embodiment of the present invention. There is shown an alternate retainer 20'. The retainer 20' also is formed from planar metal sheet having formed therein plurality of sets of opposing and spaced U-shaped slots 22a-c.
20 As described above, the sides 26a and b include the plurality of aligned openings 24a and b. The planar sheet similarly defines the ends 42 and center member 40. The sets of slots are axially spaced at 44 and b.

Upon rolling over the planar sheet 21', a
25 substantially cylindrical retainer 20' is formed. The members 60a-f of the planar sheet 21' form a plurality of wing-like structures extending from the general cylindrical shape of the retainer 20'. In this configuration the members 60a-f form a plurality
30 of openings 70a-f about the periphery of the retainer 20' and the spaces 44 form a middle band 52c and d. As will be seen from the discussion below, it may be

-7-

preferable to locate some of the openings 24 so that they are aligned with the spacings 44 (i.e. bands 52 c and d).

In its normal mode of operation, the retainer 20
5 or 20' provides a housing for the gas generator 50. FIGURE 9 illustrates a cross-sectional view of a completed assembly showing a gas generator 50 positioned within a retainer such as retainer 20. FIGURE 5 would also represent a cross-sectional view
10 of the embodiment of FIGURES 7 and 8.

In its assembled form, a bolt 80 having external threads 82 is received through the registered openings 24a and b and urges the gas generator 50 forwardly against the inner walls of the bands 52 and
15 center member 40, i.e., side 54. The bolt 80 may be secured to the retainer by a threaded nut 84 shown in greater detail in FIGURE 11. In this embodiment, a threaded nut 84, one for each opening such as 24a-b, is secured to the inner wall of side 26a. As the
20 bolt 80 is inserted within the threads of the nut 84, its end 85 engages a wall 86 of the gas generator 50, thereby urging the gas generator into the bands 52 and side 54 of the retainer 20. Since the gas generator 50 is most often fabricated of a soft metal
25 such as aluminum, the forward, compressive motion of each bolt 82 will create a respective indentation 88 shown in exaggerated scale, within the wall 86 of the gas generator and to positively secure the gas generator to the retainer 20. As can be seen, the
30 extension of the bolt 80 into the gas generator 50 secures it in a general radial compressive manner. In addition, the cooperation of each of the bolts 80

35

and their respective indentations 88 prevent the gas generator from moving laterally within the retainer 20. Each bolt 80 may include a slot or recess to facilitate turning.

5 As can be seen from the FIGURES, when the gas generator is secured in place a portion of its wall 86 is in mating engagement with a portion of the bands 52 and side 54. Consequently, it is envisioned that the openings 90 (see FIGURE 9) of the gas
10 generator will be positioned in direct communication with the openings 62 (or 70) to permit the unimpeded transport of the gases to vacillitate an efficient expansion of an air bag 100. The propellant within the gas generator 50 is not shown.

15 As can be seen from the above, the various bands 52 provide for the primary mode of securement of the gas generator 50 within the formed cylinder 28 and the front facing side wall 54 a secondary mode of securement. The front side 54 also adds a degree of
20 structural rigidity to the cylinder 28 (retainer 20;20'). It is within the scope of the present invention that the front side 54 may be eliminated since once the gas generator 50 is in place there is no particular need for a rigid front side 54. In
25 this situation the side 54 may be replaced by any number of bands 52 (2,3,4, etc.) forming a corresponding number of wing-like members (projections) 62. As an example, and with reference to FIGURE 7, the various slots 22 would extend into
30 the middle of the sheet 21'. The various projections 62 could be cut to a length corresponding to that illustrated in FIGURE 7. Upon the forming of the

retainer, such retainer would include the rear side 56, a plurality of bands 52 and projections extending therefrom. By eliminating the "side" material between the bands 52 would now expose a greater
5 frontal area of the gas generator 50 yielding a greater option in the placement of its opening 90.

During the generation of gas by the gas generator 50, an extreme amount of heat is generated. It is desirable to protect the air bag
10 100 from these heated gases to prevent same from melting and/or burning. The various wing-like members 60 of the various embodiments of the retainer 20 and 20' extend substantially tangentially outward from the rear of the rolled over retainer 20. In
15 this configuration the various portions 60 provide a heat shield for the air bag 100 and also direct the hot gases, shown as arrows 92, forwardly into the air bag.

The air bag 100 in FIGURE 9 is shown in its
20 folded orientation secured to a retainer such as 20. One such air bag that is usable with the present invention is shown in our copending, commonly owned, United States Patent Application, Serial No. 350,431, which is incorporated herein by reference. This air
25 bag comprises a nylon-like pillow enclosed at one end and having an open end that includes flaps 102a and 102b. The flaps include a plurality of registered openings 106a and 106b, see FIGURES 9,13,14, which when in overlapping configuration about the retainer
30 20 are aligned to the openings 24 which are positioned about the bolt 80 so that it passes therethrough.

-10-

The air bag is maintained in its folded orientation relative to the retainer 20 by a band or material such as 110 received thereabout. The material (sack, band, etc.) 110 is chosen of a material having a tensile stress sufficient to maintain the bag 100 in its pre-deployed, folded condition. The strength of the material is such that during initial deployment of the air bag 100 the deployment forces are sufficient to rupture it, thereby permitting the bag 100 to expand with negligible restriction. The material used may be a plastic film, cloth or spun bonded olefin material such as that manufactured under the name of TYVEK manufactured by E. I. DuPont.

A further advantage of the present invention is that the air bag 100 and securing material 110 can be mounted to the retainer 20 prior to insertion of the gas generator. This permits the partial assembly of the retainer/air bag/securing material independent of the gas generator such that the subassembly can be stored in an environment that might be considered hostile to the gas generator.

FIGURE 10 illustrates an exploded view of a portion of FIGURE 9 and illustrates an alternate means of securing the ends 26 of the sheet 21 and for supporting the bolt 80. In this embodiment the set of openings 24a are made slightly wider than the corresponding set of openings 24b. A clinch nut or rivet 140 having internal threads 142 is inserted within the openings 24a and b. The clinch nut 140 includes a clinching end 144 which when formed secures the ends 26a and b in place thereabout. The

-11-

bolt 80 is thereafter threaded through the clinch nut 140 and into engagement with the gas generator 50.

The following describes a typical assembly sequence for use with the present invention. The
5 planar sheet 21 is formed into a general cylindrical shape as shown in FIGURE 2. While a circular cylinder is shown other shapes are within the scope of the invention. The bolts 80 would be threaded into corresponding nuts 82, cinch nuts 140 etc., by a
10 screwdriver or other means by virtue of the slot or recess 90 at the end of the bolts 80. The air bag 100 with its overlapping flaps 102 are placed about the retainer and the associated openings 106 fitted over each of the bolts 80 in overlapping
15 configuration. The securement material 110 is then placed about the retainer 20, air bag 100 and bolts 80, forming a configuration similar to that shown in FIGURE 9 and 12. Such assembly may be placed within a partial shroud such as 124 or within an outer can
20 130 such as that shown in FIGURE 8. As can be appreciated, the shroud 124 or can 130 can be formed as an integral portion of the vehicle's instrument panel or as a separate element. If a partial shroud is used the retainer 20 with air bag, etc. is
25 positioned therein with bolts 80 received in aligned openings 126. The gas generator is thereafter received within the open end 122 of the retainer 20. If a can such as 130 is used upon placement of the retainer 20, air bag 100, etc., within the can, the
30 bolts 80 will extend through cooperating openings 134 in a rear wall thereof. The gas generator may then be slid through an opening 136 in a side wall 138 and

-12-

into the retainer 20. Thereafter, the bolts would be moved to engage the gas generator in its secured configuration and a nut 140 positioned about each bolt 80 to secure the gas generator 50, retainer, etc. 5 within the can 130 or shroud 124. The can 130 or shroud 120 may be attached to structurally sound members, shown diagrammatically as 138, of the vehicle proximate the instrument panel for proper mounting of the above-described device. A portion of 10 the instrument panel or separate cover (not shown) is placed over the air bag.

As can be seen from the above, the retainers 20 or 20' secure the gas generator 50 and provide heat shielding functions to protect and inflate the air 15 bag. By attaching the retainer to the vehicle structure via the bolts 80 or other means, permits the shroud 124 or can 130 to be fabricated of an extremely light weight material such as plastic since the reaction forces generated upon ignition of the 20 gas generator are transferred directly to the vehicle support members 138. The shroud 124 and/or can 130 can, of course, be themselves structural members designed to absorb a portion of the reaction force, however, in this case such elements, i.e., the shroud 25 and can, would be fabricated of metal or the like.

Reference is made to FIGURE 14 which illustrates the air bag 100 in its inflated position. The retainer is shown schematically at 20 and is placed in a known manner within an upper top portion of the 30 vehicle's dashboard (not shown) such that upon inflation the air bag expands and impacts a windshield 150. Thereafter, the air bag is deflected

forwardly and downwardly toward the occupant. To assist in the definition of the trajectory that the air bag takes upon inflation, and to somewhat define its inflated shape, many air bags include tethers
5 such as 152a and b. These tethers as is known in the art comprise reinforced material portions that are typically sewn to selected portions within the interior of the air bag 100. As an example of one type of tether used in the art, is a reinforced
10 narrow band of material similar to seat belt webbing. This tether is typically sewn across the face 154 of the air bag at locations 156a and/or b. The tether extends toward the narrowed neck portion 158 of the air bag and had typically been sewn
15 together at location 160. Another type of tether is that formed by a trapezoidal piece of material having its wider end sewn to the air bag 100 at location 156 and its narrower end, i.e., approximate the neck 158 of the air bag sewn at location 160. The process of
20 sewing the tether at the forward location 156 of the air bag is a relatively straightforward operation. However, the process of sewing the tether at location 160 is considerably more difficult. If two tethers 152a and b are used, the sewing operation typically
25 requires that both tethers be sewn together and to the air bag at location 160. This problem can be obviated by the present invention. It is envisioned that the tethers 152 would be sewn to the air bag at location(s) 156 in the normal manner. The tethers
30 would as known in the art be loosely received relative to the sides of the air bag and extend toward the narrowed neck 158 of the air bag. The

tethers, however, in the present invention would include an additional length of material generally shown as 162 which would be brought into engagement with the rear side of the retainer 22. This
5 additional material 162 would also include openings 164 to permit the receipt of the bolts 80. In this manner the tethers can now be fixed to a permanent and definite reference point to more precisely define the trajectory of the air bag and any tether reaction
10 loading supported by the retainer 22 as opposed to being absorbed by other portions of the air bag.

Many changes and modifications in the above described embodiment of the invention can, of course,
15 be carried out without departing from the scope thereof. Accordingly, that scope is intended to be limited only by the scope of the appended claims.

20

25

30

35

IN THE CLAIMS

1. A device (20) comprising a planar metal sheet (21;21') having formed thereon at least a first set of opposing shaped slots (60a,b) such that upon forming the planar sheet as an open ended (122) generally cylindrical member or cylinder (28) first portions of the sheet, defined by the slots, extend away from the surface of the formed cylindrical member and form in conjunction with other surfaces of the sheet a plurality of first apertures (62a,b), and the extending first portions serving to define heat shield means for shielding a portion of an air bag (100), adapted to be secured thereabout, from hot gas generated by a gas generator (50), the formed cylindrical member (28) adapted to receive a gas generator (50) therein, the device including securement means, interacting with a rearward portion of the cylindrical member and adapted for urging a gas generator (50) into forward facing portions of the cylindrical member, for securing same in place.
2. The device as defined in Claim 1 where the sides (26a,b) of the sheet (21, 21'), upon forming the cylinder are in overlapping engagement forming the rearward portion (56) of the cylinder, substantially opposite the apertures (62a,b).
3. The device as defined in Claim 1 wherein the end portions (42a,b) of the sheet, outboard of the slots, upon formation of the cylinder, define respective end bands (52a,b).

-16-

4. The device as defined in Claim 1 wherein a center portion of the sheet (21), generally parallel to the sheet sides 24, upon forming the cylinder, defines an axially extending front side (54) circumferentially separating opposing apertures (62).

5. The device as defined in Claim 1 wherein the securement means comprises a first member (80) radially advanceable through the rearward portion of the cylinder (28) and adapted to engage a portion of the gas generator urging same away from the rearward portion and against forward facing portions.

6. The device as defined in Claim 5 wherein an outer wall of the gas generator is deformable and wherein each first member (80) compressively loads the wall to form a respective depression, and wherein each depression and first member cooperate to radially and axially secure the gas generator to the cylinder (28).

7. The device as defined in Claim 5 wherein the first member includes a bolt (80) having external threads thereof, and where the securement means further includes first means, at the rearward portion, for receiving the bolt.

8. The device as defined in Claim 7 wherein each side (26) of the planar sheet (21) includes a set of first openings (24a,b) which with the sheet sides in overlapping configuration, are registered and coaxially aligned one to the other, and through which a corresponding first member (80) may be received, and a corresponding first means attached thereto.

9. The device as defined in Claim 8 wherein the respective ones of the first set of openings are in line with corresponding forward facing portions of the cylinder (28).

10. The device as defined in Claim 8 wherein each first means includes a threaded member (82) attached to a corresponding one of the openings (24a,b) through which a corresponding first member is thereby received.

11. The device as defined in Claim 1 including a second set (22c,d) of opposing shaped slots, axially spaced from the first set of slots (22a,b), such that upon forming the cylinder, second portions (60c,d) of the sheet defined by the second set of slots, tend to extend away from the surface of the cylinder, substantially parallel to the extending first portions to form a plurality of second apertures (62c-f).

12. The device as defined in Claim 1 further including an air bag (100), in folded configuration, enveloping the cylinder (28) and extending first portions (60) and through which extends each first member (80), the extending first portions (60) maintain portions of the air bag (100) spaced from the at least first apertures (62c,d).

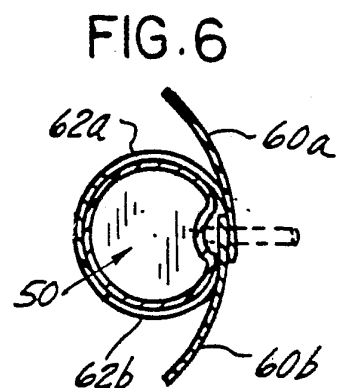
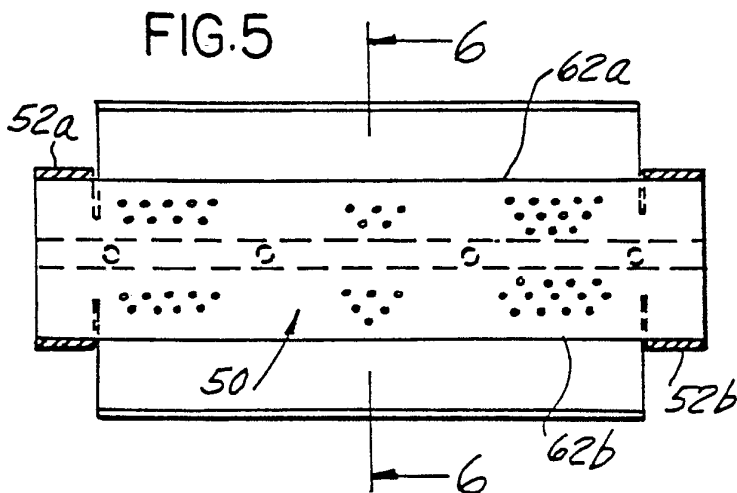
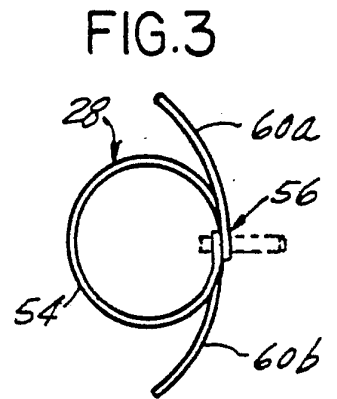
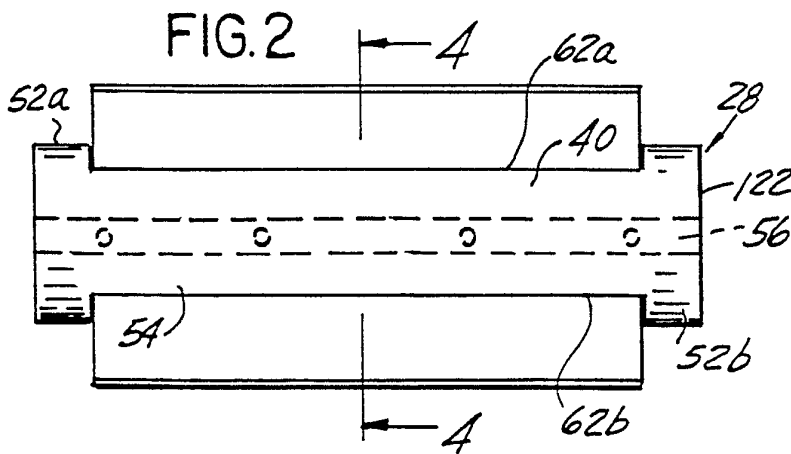
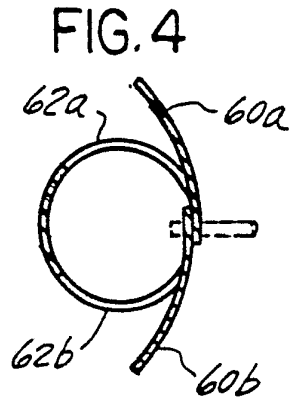
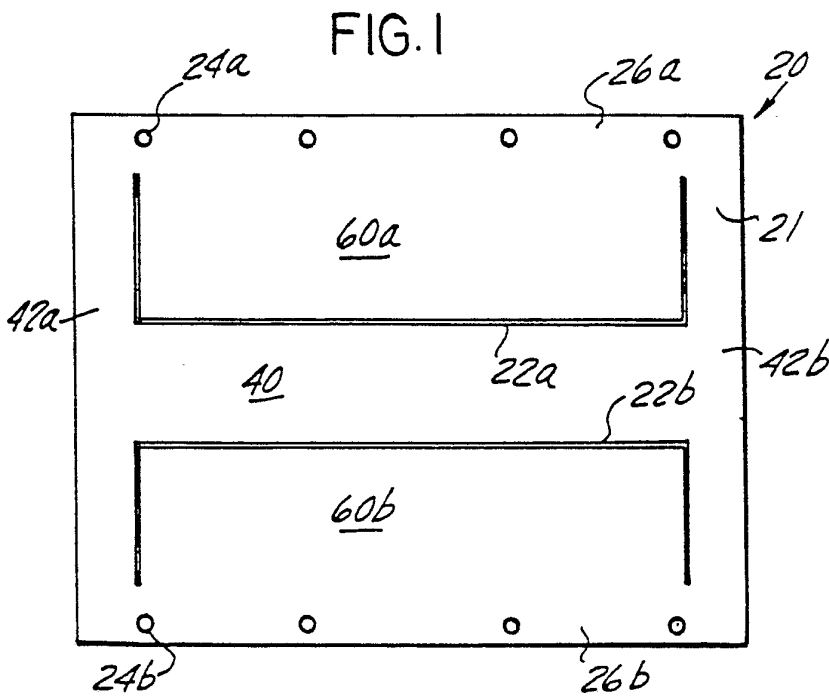

FIG. 7

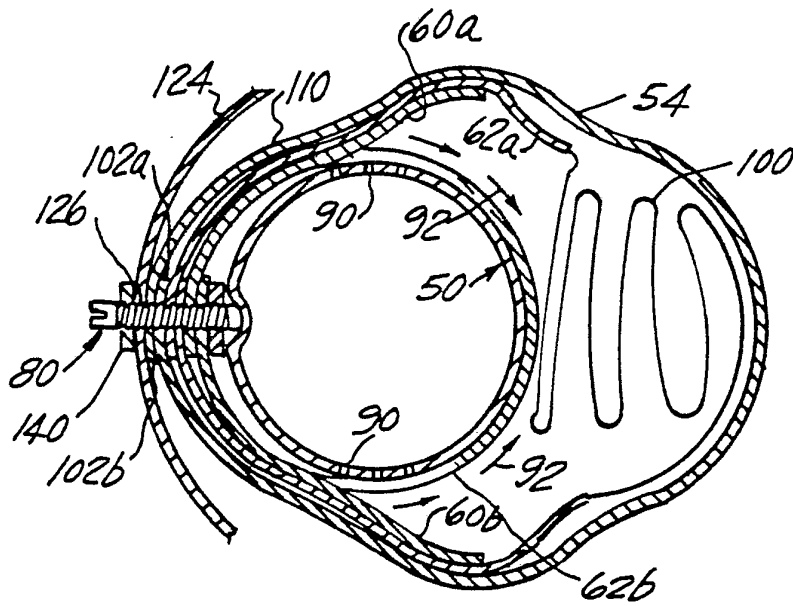
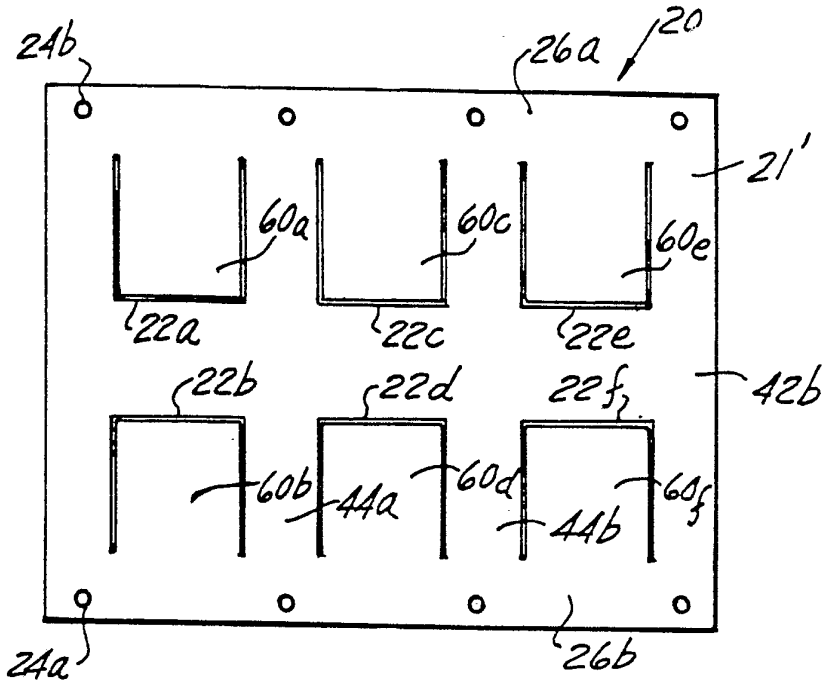
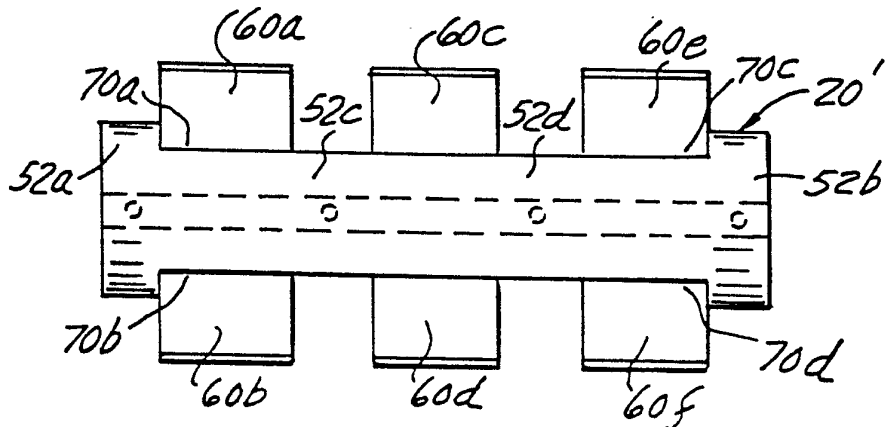

FIG. 9

FIG. 8



SUBSTITUTE SHEET

FIG.12

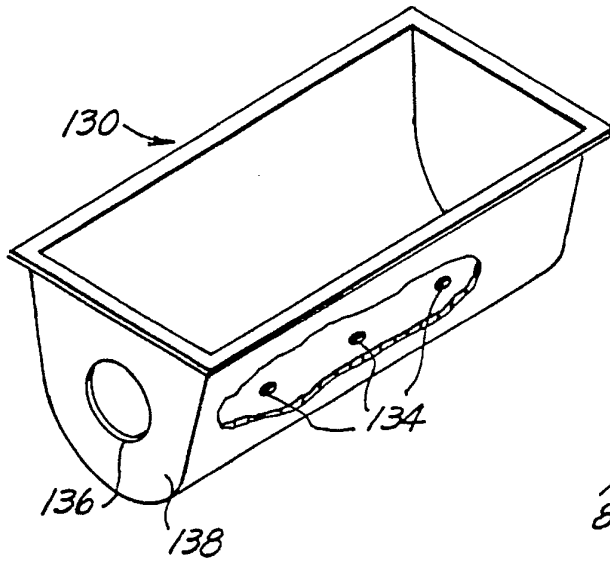

FIG.13

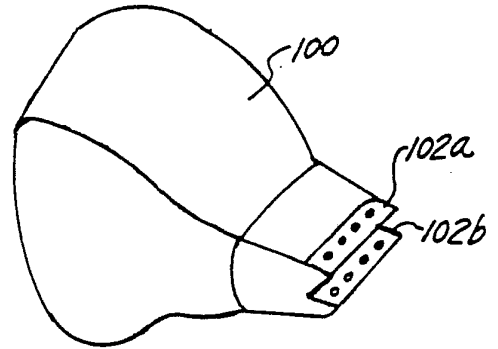

FIG.14

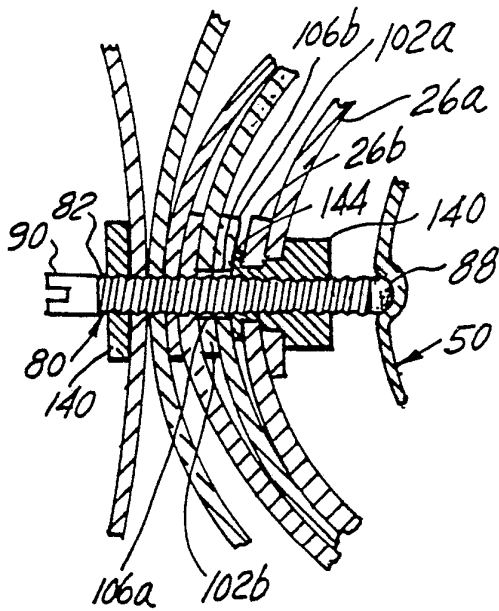
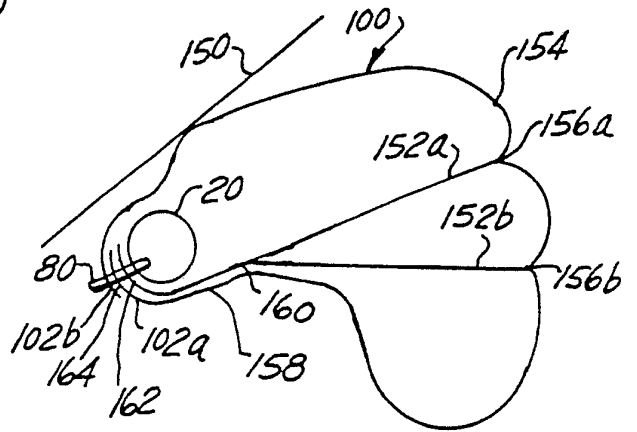

FIG.10

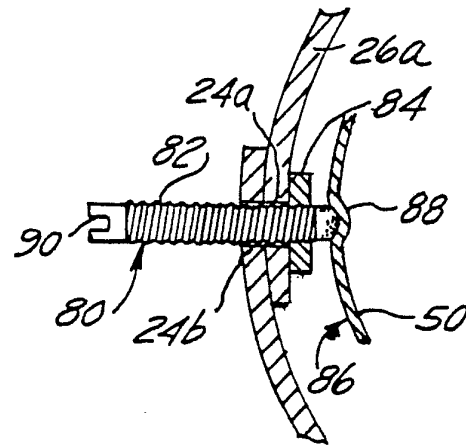
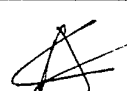

FIG.11

INTERNATIONAL SEARCH REPORT

International Application No

PCT/US 90/03604

I. CLASSIFICATION OF SUBJECT MATTER (if several classification symbols apply, indicate all) ⁶		
According to International Patent Classification (IPC) or to both National Classification and IPC Int.Cl. 5 B60R21/26		
II. FIELDS SEARCHED		
Minimum Documentation Searched ⁷		
Classification System	Classification Symbols	
Int.Cl. 5	B60R	
Documentation Searched other than Minimum Documentation to the Extent that such Documents are Included in the Fields Searched ⁸		
III. DOCUMENTS CONSIDERED TO BE RELEVANT ⁹		
Category ¹⁰	Citation of Document, ¹¹ with indication, where appropriate, of the relevant passages ¹²	Relevant to Claim No. ¹³
A	US,A,3853332 (LYNCH) 10 December 1974 see figures 1, 2 see column 2, line 12 - column 3, line 11 ---	1, 5, 12
A	GB,A,1503373 (NISSAN) 08 March 1978 see figures 1-9 see page 1, lines 78 - 83 see page 2, line 98 - page 4, line 52 ---	1, 12
A	US,A,4332398 (SMITH) 01 June 1982 see abstract; figures 1-6 see column 2, line 3 - column 3, line 56 ---	1, 5, 12
A	US,A,4191392 (BARNETT) 04 March 1980 see figures 1-6 see column 2, line 58 column 5, line 51 ---	1, 5, 12
<p>Special categories of cited documents¹⁴</p> <p>"A" document defining the general state of the art which is not considered to be of particular relevance</p> <p>"E" earlier document but published on or after the international filing date</p> <p>"I" document which may throw doubts on priority claim(s) or which is cited to establish the publication date of another citation or other special reason (as specified)</p> <p>"O" document referring to an oral disclosure, use, exhibition or other means</p> <p>"P" document published prior to the international filing date but later than the priority date claimed</p> <p>"T" later document published after the international filing date or priority date and not in conflict with the application but cited to understand the principle or theory underlying the invention</p> <p>"X" document of particular relevance; the claimed invention cannot be considered novel or cannot be considered to involve an inventive step</p> <p>"Y" document of particular relevance; the claimed invention cannot be considered to involve an inventive step when the document is combined with one or more other such documents, such combination being obvious to a person skilled in the art.</p> <p>"&" document member of the same patent family</p>		
IV. CERTIFICATION		
Date of the Actual Completion of the International Search 31 OCTOBER 1990		Date of Mailing of this International Search Report 20. 11. 90
International Searching Authority EUROPEAN PATENT OFFICE		Signature of Authorized Officer D' SYLVA C. 

ANNEX TO THE INTERNATIONAL SEARCH REPORT
ON INTERNATIONAL PATENT APPLICATION NO. US 9003604

SA 38885

This annex lists the patent family members relating to the patent documents cited in the above-mentioned international search report. The members are as contained in the European Patent Office EDP file on The European Patent Office is in no way liable for these particulars which are merely given for the purpose of information. 31/10/90

Patent document cited in search report	Publication date	Patent family member(s)	Publication date
US-A-3853332	10-12-74	None	
GB-A-1503373	08-03-78	JP-A, B, C51060331 DE-A- 2547724 US-A- 4068862 US-A- 4178017	26-05-76 26-05-76 17-01-78 11-12-79
US-A-4332398	01-06-82	None	
US-A-4191392	04-03-80	None	

PO FORM 19879

For more details about this annex : see Official Journal of the European Patent Office, No. 12/82