

(19) World Intellectual Property Organization
International Bureau



(43) International Publication Date
23 February 2006 (23.02.2006)

PCT

(10) International Publication Number
WO 2006/020127 A1

- (51) International Patent Classification⁷: **A61F 2/06**
- (21) International Application Number:
PCT/US2005/025293
- (22) International Filing Date: 14 July 2005 (14.07.2005)
- (25) Filing Language: English
- (26) Publication Language: English
- (30) Priority Data:
10/892,005 14 July 2004 (14.07.2004) US
- (71) Applicant (for all designated States except US): **BOSTON SCIENTIFIC SCIMED, INC.** [US/US]; One Scimed Place, Maple Grove, MA 5531-1566 (US).
- (72) Inventors; and
- (75) Inventors/Applicants (for US only): **ROSENTHAL, Arthur, L.** [US/US]; 780 Boylston Street, Boston, MA 02199 (US). **EHR, Timothy, G.J.** [US/US]; 19017 Zane Street, N.W., Elk River, MN 55330 (US). **MILLER, Matthew** [US/US]; 2680 S. Shore Boulevard, White Bear Lake, MN 55110 (US).
- (74) Agents: **STERN, Gidon, D.** et al.; Jones Day, 222 East 41st Street, New York, NY 10017-6702 (US).
- (81) Designated States (unless otherwise indicated, for every kind of national protection available): AE, AG, AL, AM, AT, AU, AZ, BA, BB, BG, BR, BW, BY, BZ, CA, CH, CN, CO, CR, CU, CZ, DE, DK, DM, DZ, EC, EE, EG, ES, FI, GB, GD, GE, GH, GM, HR, HU, ID, IL, IN, IS, JP, KE, KG, KM, KP, KR, KZ, LC, LK, LR, LS, LT, LU, LV, MA, MD, MG, MK, MN, MW, MX, MZ, NA, NG, NI, NO, NZ, OM, PG, PH, PL, PT, RO, RU, SC, SD, SE, SG, SK, SL, SM, SY, TJ, TM, TN, TR, TT, TZ, UA, UG, US, UZ, VC, VN, YU, ZA, ZM, ZW.
- (84) Designated States (unless otherwise indicated, for every kind of regional protection available): ARIPO (BW, GH, GM, KE, LS, MW, MZ, NA, SD, SL, SZ, TZ, UG, ZM, ZW), Eurasian (AM, AZ, BY, KG, KZ, MD, RU, TJ, TM), European (AT, BE, BG, CH, CY, CZ, DE, DK, EE, ES, FI, FR, GB, GR, HU, IE, IS, IT, LT, LU, LV, MC, NL, PL, PT, RO, SE, SI, SK, TR), OAPI (BF, BJ, CF, CG, CI, CM, GA, GN, GQ, GW, ML, MR, NE, SN, TD, TG).
- Published:**
— with international search report
- For two-letter codes and other abbreviations, refer to the "Guidance Notes on Codes and Abbreviations" appearing at the beginning of each regular issue of the PCT Gazette.*



WO 2006/020127 A1

(54) Title: MEDICAL DEVICE FOR DELIVERING BIOLOGICALLY ACTIVE MATERIAL

(57) Abstract: This invention relates generally to a stent comprising a plurality of struts and a plurality of projecting elements integral with the struts. At least some of the struts and some of the projecting elements comprise a biologically active material. The struts are configured in a tubular shape or tubular sidewall having two ends. One end of at least one of the projecting elements defines an end of the stent when the stent is expanded. The invention is also directed to a method for delivering the biologically active material to body tissue of a patient by inserting such an expandable stent into body of the patient. The invention is further directed to a system comprising the expandable stent and a balloon catheter for expanding the stent.

MEDICAL DEVICE FOR DELIVERING BIOLOGICALLY ACTIVE MATERIAL**FIELD OF THE INVENTION**

[0001] This is a continuation-in-part of co-pending U.S. Patent Application Serial No. 10/062,794, filed January 31, 2002, which is incorporated herein by reference.

[0002] This invention relates generally to medical devices, such as stents, for delivering a biologically active material to a desired location within the body of a patient. More particularly, the invention is directed to a medical device comprising a plurality of struts and a plurality of non-structural elements integral with the struts, wherein the struts and the non-structural elements comprise the biologically active material. The invention is also directed to a method for delivering the biologically active material to the body tissue of a patient by inserting this medical device into the body of the patient, and further a method for designing such medical device.

[0003] The invention is also directed to a medical device comprising a plurality of struts and having an outer surface which has a middle section and end sections. The end sections of the outer surface either (1) contain a greater amount of a biologically active material per unit length of the outer surface or (2) have a greater capacity per unit length to contain such material than the middle section of the outer surface by having a greater surface area per unit length of the outer surface than the middle section or having a greater affinity for the biologically active material per unit length of the outer surface than the middle section.

[0004] Furthermore, this invention relates generally to a stent comprising a plurality of struts and a plurality of projecting elements integral with the struts. At least some of the struts and some of the projecting elements comprise a biologically active material. The struts are configured in a tubular shape or tubular sidewall having two ends. One end of at least one of the projecting elements defines the end of the stent when the stent is expanded. The invention is also directed to a method for delivering the biologically active material to the body tissue of a patient by inserting such an expandable stent into the body of the patient. The invention is further directed to a system comprising the expandable stent and a balloon catheter for expanding the stent.

BACKGROUND OF THE INVENTION

[0005] Balloon angioplasty has been very effective in treating stenosis, *i.e.*, to open blocked vessels and restore normal levels of blood flow. However, although once a blocked vessel is opened, the treated vessel can restenose, *i.e.*, reclose, shortly after the procedure. Thus, patients may have to undergo repeated angioplasty or even surgery.

[0006] Implantable stent prosthesis or stents are used to reduce restenosis after balloon angioplasty or other procedures using catheters. A stent in the form of a wire mesh tube props open an artery that has recently been cleared using angioplasty. A balloon expandable stent is collapsed to a small diameter, placed over an angioplasty balloon catheter and moved into the area of the blockage. When the balloon is inflated, the stent expands, locks in place and forms a scaffold to hold the artery open. A self-expandable stent is collapsed to a small diameter by placing in a sheath, and expands in the area of the blockage when the sheath surrounding the stent is removed. Usually, the stent stays in the artery permanently, holds it open, improves blood flow to the heart muscle and relieves symptoms. The stent procedure is fairly common, and various types of stents have been developed and actually used.

[0007] A variety of medical conditions have been treated by introducing an insertable medical device having a coating for release of a biologically active material. For example, various types of biologically active material-coated medical devices, such as stents, have been proposed for localized delivery of the biologically active material to a body lumen, such as to reduce the possibility of restenosis. *See, e.g.*, U.S. Patent No. 6,099,562 to Ding *et al.* However, it has been noted that, with existing coated medical devices, the release profile of a biologically active material may not be uniform along the entire length of the medical device.

[0008] For example, even if a biologically active material having a pharmacological effect is delivered to a body tissue, such effect may not result if the concentration of the biologically active material in the body tissue is below a certain concentration. Such concentration is referred to as the minimum effective concentration (C_{\min}) of the biologically active material in the body tissue. Each biologically active material has different C_{\min} . C_{\min} of a biologically active material also varies depending on the type of body tissue to which it is delivered. On the other hand, a biologically active material becomes toxic if its concentration is higher than a certain concentration. Such concentration is referred to as the maximum effective concentration C_{\max} . In addition, it is insufficient that the mean concentration of the biologically active material delivered through out the body tissue to be treated is greater than C_{\min} and smaller than C_{\max} . The

concentration of the biologically active material at each and every area throughout the body tissue to be treated should be equal to or greater than C_{\min} but equal to or smaller than C_{\max} of the biologically active material. For instance, when a coated stent comprised of struts, such as the stent shown in Fig. 1, is used as a medical device for delivering a hydrophobic biologically active material, concentrations of the biologically active material may significantly differ between the regions of the tissue adjacent to the struts and the regions of the tissue farther from the struts. See Hwang *et al.*, <http://www.circulationaha.org> (accepted in April 2001). Even if the mean concentration of the biologically active material in the tissue surrounding the stent is above C_{\min} of the biologically active material and at or under C_{\max} , the concentrations at certain regions of the tissue to be treated, which are farther from the struts, may not reach C_{\min} . Also, if the amount of the biologically active material in the coating is increased to achieve a concentration higher than C_{\min} at all regions of the tissue to be treated, then the concentrations at regions of the tissue adjacent to the struts may exceed the toxic levels, as explained below using the figures.

[0009] In Fig. 1, the coated stent 10 is placed in a blood vessel 15 having a vessel wall 12 to be treated. This vessel wall is surrounded by tissue 12a. The biologically active material coated on struts 13 of the stent 10 is released into the vessel wall 12 to be treated. Fig. 2 is a cross sectional view along line A of the stent 10 in Fig. 1. Fig. 2 also shows the concentration levels of the biologically active material in each area surrounding the struts 13 at a certain time after the insertion of the stent into the vessel 15. The area adjacent to the struts, *i.e.*, the area between the struts 13 and line 16, has a concentration level at or below C_{\max} , which is just below the toxic level. The farther from the struts 13 the tissue to be treated is located, the lower the concentration of the biologically active material delivered to the tissue becomes. However, the area between line 18 and line 19 has the concentration level at or higher than C_{\min} . A concentration of the biologically active material in the area outside line 19 is below C_{\min} .

[0010] Also, Figs. 2A and 2B clearly show that there are gaps between each strut 13 wherein the vessel wall to be treated does not receive sufficient biologically active material to have C_{\min} . The areas within line 19, *i.e.*, having concentrations above C_{\min} , may be increased in size to include more area of the vessel wall 12 to be treated, if the amount of the biologically active material on the struts 13 is increased. However, by doing so, the concentration of the biologically active material in the area adjacent to the struts 13 may exceed the toxic level. Accordingly, there is a need for a medical device comprising a plurality of struts that can achieve the biologically active material concentration that is above C_{\min} and below toxic levels throughout the tissue.

[0011] Also, generally with existing coated medical devices, the coating is uniformly applied along the entire length of the device or surface of the device. For example, conventional coated stents are coated uniformly along the entire length of the surface of the device. The biologically active material-concentration-profile along the length of the coated surface may be in the shape of a bell-curve, wherein the concentration of the biologically active material released at the middle of the surface is greater than the concentration of the biologically active material released at the ends of the coated surface. This uneven concentration-profile along the length of the coated surface may lead to the application of an inadequate or sub-optimal dosage of the biologically active material to the body tissue located at the ends of the coated surface. It is possible that such uneven local concentration of the biologically active material along the length of the coated surface of the medical device may lead to undesired effects. For example, in the case of a biologically active material-coated stent used to prevent or treat restenosis, if the amount of biologically active material delivered to the tissue located at the ends of the stent is sub-optimal, it is possible that restenosis may occur in such tissue. In fact, recent data show that restenosis occurs at the edges of the stents about five times more often than at the middle portion of stents, *i.e.*, the "edge effect". The "edge effect" may be caused by the lesser concentration of biological active material that is present in body tissue in proximity to the edges of the stent.

[0012] The biologically active material dosage at the tissue located at the ends of the coated surface of the medical device can be increased if the concentration or amount of the biologically active material is increased along the entire length of the surface. However, by increasing the concentration or amount of biologically active material released along the entire surface, the dosage delivered to tissue located at the middle of the surface may be too great or even at toxic levels. Thus, there is a need for a medical device that can realize a more uniform concentration-profile for biologically active material along the entire length of a coated surface of a medical device and avoid the possibility of undesired effects accompanied by an uneven biologically active material concentration-profile.

[0013] Moreover, medical devices wherein a biologically active material is uniformly coated on the entire outer surface of the medical devices that is exposed to body tissue are generally used to deliver such biologically active material to specific parts of such body tissue. For instance, such devices are used to treat lesions in body lumen. However, because the entire outer surface of the device contains the biologically active material, this biologically active material will be delivered to healthy body tissue in addition to the lesion. Treatment of healthy tissue with the biologically active material is not only unnecessary but

maybe harmful. Accordingly, there is a need for a medical device that can realize an asymmetry release-profile of biologically active material to deliver such material to only a limited region of the body tissue that requires the biologically active material.

[0014] Also, the pressure or stress that the stent exerts against the surrounding tissue is concentrated at the edges of the stent. Such concentrated stress may also contribute to the "edge effect". Therefore, to reduce the "edge effect," there is a need for a stent having a structure wherein the stress exerted against the body tissue in proximity to the edges of the stent is reduced and such body tissue is exposed to a greater amount of biologically active material.

[0015] Furthermore, when a balloon and a balloon expandable stent disposed on the balloon are expanded, the ends of the stent generally do not extend to the ends of the balloon, *i.e.*, the ends of the stent do not cover the entire balloon's length. Thus, the balloon inflates beyond the margins or ends of the stents, and the portions of the balloon beyond the stents' ends directly contact the patient's lumen wall. Such direct contact with the balloon may cause a tissue injury in the patient's lumen wall. Also, to reduce such potential injury by using a balloon having a length which is matched exactly to a stent length is impractical because: (1) it is difficult to align the stent with the balloon during crimping; (2) both stent and balloon are manufactured within a small but finite tolerance that provides a range of component sizes; and (3) stents will be shortened during expansion. Therefore, there is a need for a stent having structure to reduce such potential injury caused by the ends or edges of the balloon.

SUMMARY OF THE INVENTION

[0016] These and other objectives are accomplished by the present invention. To achieve the aforementioned objectives, we have invented a medical device for delivering a biologically active material into a body tissue of a patient; a method for designing such device; and a method for delivery of a biologically active material to a body tissue.

[0017] The medical device of the invention is a medical device for delivery of biologically active materials to a body tissue of a patient in need of treatment. The medical device comprises struts and non-structural elements integral with the struts, and those struts and non-structural elements comprise the biologically active material. In an embodiment, the medical device comprises a tubular portion having an outer surface, and the non-structural elements are distributed throughout the outer surface. In another embodiment, the non-structural elements are located in a radially asymmetric distribution on the outer surface. In yet another embodiment, the outer surface has end sections and a middle

section, and the end sections comprise a greater number of the non-structural elements per unit length of the outer surface than the middle section.

[0018] The present invention is also directed to a method for delivering a biologically active material to the body tissue of a patient which comprises inserting the above-mentioned medical device into the body of the patient.

[0019] Further, the present invention is directed to a method for designing such medical device. The method comprises: providing a preliminary medical device comprising struts in a geometric pattern wherein the struts comprise the biologically active material; determining a concentration-profile for the biologically active material which is released from the preliminary medical device; and modifying the geometric pattern of the struts of the preliminary medical device by incorporating non-structural elements comprising the biologically active material that are integral with the struts to achieve more desired distribution of the biologically active material in the body tissue.

[0020] The present invention is also directed to a medical device insertable into the body of a patient. The medical device has an outer surface comprising struts, and the outer surface has a middle section and end sections. The end sections have a greater available surface area per unit length of the outer surface than the middle section. In another embodiment, the end sections have greater affinity for the biologically active material per unit length of the outer surface than the middle section. In yet another embodiment, the end sections have a greater amount of the biologically active material per unit length of the outer surface than the middle section. Further, in another embodiment, at least a part of each of the middle section and the end sections is covered with a coating comprising the biologically active material, and the middle section comprises a barrier layer placed over the coating covering the middle section.

[0021] Moreover, the present invention provides another embodiment of the medical device for treating body tissue. The medical device comprises an outer surface comprising struts. The outer surface has a rectangular portion having a greater capacity for carrying or containing a biologically active material per unit length of the outer surface than the parts of the outer surface that are outside the rectangular portion. In the alternative, the rectangular portion may have a greater affinity for the biologically active material. The present invention is also directed to a method for delivering a biologically active material by inserting the above-mentioned medical device comprising the biologically active material in such a way that the rectangular portion is in direct contact with the body tissue in need of treatment.

[0022] Additionally, the present invention is directed to an expandable stent comprising two ends and a tubular sidewall between the two ends. The sidewall comprises a plurality of struts, and a plurality of projecting elements located proximate at least one stent end. Each projecting element comprises a first end and a second end, in which the first projecting element end is integral with or attached to a strut. The second projecting element end is capable of defining at least one stent end when the stent is in an expanded position. Also, at least one of the struts or at least one of the projecting elements comprises a biologically active material.

[0023] Moreover, the invention is directed to a balloon expandable stent comprising two ends and a tubular sidewall between the two ends, in which the sidewall comprises a plurality of struts and a plurality of projecting elements proximate at least one stent end. Each projecting element comprises a first end and a second end. The first projecting element end is integral with or attached to a strut; and the second projecting element end is capable of defining at least one stent end when the stent is in an expanded position. At least one of the projecting elements comprise a biologically active material.

[0024] In addition, the present invention is directed to a system comprising a balloon expandable stent and a balloon catheter having an inflatable balloon for expanding the stent to an expanded position. The stent comprises two ends and a tubular sidewall between the two ends, and the sidewall comprises a plurality of struts as well as a plurality of projecting elements proximate at least one stent end. Each projecting element comprises a first end and a second end. The first projecting element end is integral with or attached to a strut; and the second projecting element end is capable of defining at least one stent end when the stent is in the expanded position. Also, at least one of the struts or one of the projecting elements comprise a biologically active material.

BRIEF DESCRIPTION OF THE DRAWINGS

[0025] Fig. 1 depicts a side view of a stent without non-structural elements in a cross-sectioned blood vessel. The stent is coated with a biologically active material.

[0026] Figs. 2A and 2B depict cross sectional views of the stent and blood vessel of Fig. 1 along line A-A and line B-B (shown in Fig. 2A), respectively. Figs. 2A and 2B also show areas of body tissue having different concentration levels of the biologically active material.

[0027] Fig. 3 depicts a side view of a stent with non-structural elements in a cross-sectioned blood vessel. The stent is coated with a biologically active material.

[0028] Figs. 4A and 4B depict cross sectional views of the stent and blood vessel of Fig. 3 along line C-C and line D-D (shown in Fig. 4A), respectively. Figs. 4A and 4B also show areas having different concentration levels of the biologically active material.

[0029] Fig. 5 depicts struts of a conventional expandable stent.

[0030] Figs. 6-14, each depicts struts having non-functional elements integral with the struts.

[0031] Fig. 15 depicts wavy struts that have greater surface area per unit length of the strut than conventional struts.

[0032] Fig. 16 depicts struts having a greater average diameter per length of the strut than the conventional struts.

[0033] Fig. 17 depicts a simplified view of a stent having a rectangular portion of the outer surface where non-structural elements are located, and the rectangular portion is shown by hatching.

[0034] Fig. 18 depicts a perspective view of a stent wherein non-structural elements are located only in a rectangular portion of the outer surface.

[0035] Fig. 19 depicts a stent having end sections and a middle section and comprised of struts, wherein the end sections are comprised of a porous material and the middle section is comprised of a less porous material.

[0036] Fig. 20 is a simplified view of a stent which shows the outer surface, having end sections and a middle section.

[0037] Fig. 21 depicts a side view of a stent comprised of a plurality of struts and projecting elements in an unexpanded state.

[0038] Fig. 22 depicts the stent of Fig. 21 in an expanded state.

[0039] Fig. 23 depicts a projecting element in a shape of a rod having a rectangular-end integral to a strut.

[0040] Fig. 24 depicts another projecting element in a shape of a rod having a paddle-shaped end integral to a strut.

[0041] Figs. 25a-27a depict projecting elements in the shape of rods having various shaped ends integral to a strut.

[0042] Fig. 28 depicts a part of an unexpanded stent where the projecting elements are in the shape of a rod with an opening such as a loop at its end.

[0043] Fig. 29 shows the stent of Fig. 28 in an expanded state.

DETAILED DESCRIPTION OF THE INVENTION**1. MEDICAL DEVICE FOR DELIVERING BIOLOGICALLY ACTIVE MATERIAL WITH DESIRED DISTRIBUTION****1.1 NON-STRUCTURAL ELEMENTS**

[0044] Even if a biologically active material having a pharmacological effect is delivered to a body tissue, such effect may not result if the concentration of the biologically active material in the body tissue is below a certain concentration (C_{min}). On the other hand, a biologically active material becomes toxic if its concentration is higher than a certain concentration (C_{max}). The concentration of the biologically active material at each and every area throughout the body tissue to be treated should be at or above C_{min} but at or under C_{max} of the biologically active material.

[0045] When the medical device is comprised of a plurality of struts comprising a biologically active material, the body tissue located at or near a center of each "cell" of the medical device, *i.e.*, openings between the struts, tends to have the lowest concentration of the biologically active material. Such concentration can be below C_{min} . This is particularly true when the biologically active material is hydrophobic. When the concentration of the biologically active material in the tissue located at the center of each cell is lower than C_{min} , the concentration can be increased by increasing the amount of the biologically active material coated on outer surface of each strut. However, then the concentration at the tissue adjacent to the struts may exceed C_{max} .

[0046] For example, Fig. 1 depicts a coated stent 10 having a conventional geometric pattern, which is placed in a blood vessel 15 having a vessel wall 12 to be treated. The biologically active material coated on struts 13 of the stent 10 is released into the vessel wall 12 to be treated. Figs. 2A and 2B show cross sectional views along line A-A and line B-B (shown in Fig. 2A) of the stent 10 in Fig. 1 and the concentration levels of the biologically active material in each area surrounding the struts 13 at a certain time after the stent 10 was inserted into the blood vessel 15. The area adjacent to the struts, *i.e.*, the area between the struts 13 and line 16 has a concentration level at or below C_{max} , which is just below the toxic level. The farther from the struts 13 the area is located, the lower the concentration becomes. Thus, the concentration levels gradually decrease from the area between lines 16 and 17, the area between 17 and 18, to between 18 and 19. The area between line 18 and line 19 has a concentration level at or higher than C_{min} . A concentration of the biologically active material in the area outside line 19 is below C_{min} , and thus the pharmacological effects of the biologically active material does not result in the area.

[0047] Furthermore, Figs. 2A and 2B clearly show that there are gaps between each strut 13, *i.e.*, near the center of cells, wherein the vessel wall to be treated does not receive sufficient biologically active material to have C_{min} . The size of the area within line 19, *i.e.*, the areas having the concentrations above C_{min} , may be increased to include the entire area of the vessel wall 12 to be treated if the amount of the biologically active material on the struts 13 is increased. However, by doing so, the area adjacent to the struts 13 may be also increased and exceed the toxic level. Therefore, there is a need for a medical device that can ensure the concentration of the biologically active material throughout the body tissue to be treated is at least C_{min} and at most C_{max} .

[0048] To achieve such a desired distribution of a biologically active material throughout the body tissue to be treated, the embodiments of the medical device of the present invention comprise a plurality of struts and a plurality of non-structural elements integral to the struts. The struts and non-structural elements comprise the biologically active material. These non-structural elements are used to adjust the distribution of the biologically active material in the body tissue so that the desired concentration-profile for the biologically active material released from the medical device into the body tissue can be achieved. For instance, the medical device of the present invention can achieve concentrations higher than C_{min} at the tissue located at the center of cells without increasing the local concentration at an area adjacent to the struts higher than C_{max} .

[0049] An example is shown in Figs. 3, 4A and 4B. Fig. 3 depicts a coated stent 10 which is obtained by modifying the conventional geometric pattern of stent 10 shown in Fig. 1 by incorporating non-structural elements 14 integral to the struts 13. The stent 10 is placed in a blood vessel 15 having a vessel wall 12 to be treated. The biologically active material coated on struts 13 and non-structural elements 14 of the stent 10 is released into the vessel wall 12 to be treated and tissue 12a surrounding the vessel wall 12. Figs. 4A and 4B show cross sectional views along line C-C and D-D (shown in Fig. 4A) of the stent 10 in Fig. 3 and the concentration levels of the biologically active material in each area surrounding the struts 13 and the nonstructural elements 14 at a certain time after the stent 10 was inserted in the blood vessel 15. The area adjacent to the struts, *i.e.*, the area between the struts 13 or the nonstructural elements 14 and line 16 has a concentration level from at or below C_{max} , which is just below the toxic level. The farther from the struts 13 or the nonstructural elements 14 the area is located, the lower the concentration becomes. The area between line 18 and line 19 has the concentration level at or higher than C_{min} . Fig. 4A clearly shows that the stent 10 can achieve concentrations higher than C_{min} throughout the

entire area of the vessel wall 12 to be treated, even at areas located at the center of cells, without increasing the concentration at areas adjacent to the struts above C_{\max} .

[0050] The term “non-structural element” refers to an element integral with a strut, which can project from the strut or can be located along the strut. Such non-structural elements have substantially no effect on the mechanical properties of the struts, such as, for example, (1) radial strength, (2) longitudinal flexibility, (3) expansion ratio, (4) trackability and (5) profile of a medical device comprising the plurality of struts. In embodiments of the medical device of the present invention, the non-structural elements are integral with the struts, namely, they are generally made from the same material as the struts and are formed as a continuous part of the struts. Preferably, the non-structural elements and struts may be manufactured simultaneously; for example, struts having non-structural elements can be laser-ablated from a plate of metal or polymer.

[0051] Fig. 5 depicts example of conventional struts without non-structural element, and Figs. 6-14 depict examples of non-structural elements integral with the conventional struts. Shapes of the non-structural elements include, but not limited to, a straight rod (21 in Fig. 6), a cone (22 in Fig. 7), a truncated cone (not shown), a hoop (23 in Fig. 8), a knot (24 in Fig. 9), a bent rod (25 in Fig. 10), an oval (26 in Fig. 11), and a rod having heads at its ends (27 in Fig. 12 and 28 in Fig. 13). Bends in the struts (29a and 29b in Fig. 14) can be used as non-structural elements so long as they do not affect the mechanical properties of the struts.

[0052] This embodiment of the medical device of the present invention can be used for delivering any kind of biologically active material. Preferably, the biologically active material is hydrophobic, *e.g.*, paclitaxel, actinomycin, sirolimus, tacrolimus, everolimus, dexamethasone, halofuginone and hydrophobic nitric oxide adducts. Other examples of the biologically active material, coatings containing the biologically active material, and examples of the medical device are explained later in this application.

1.2 DESIGNING MEDICAL DEVICES HAVING STRUTS AND NON-STRUCTURAL ELEMENTS

[0053] The present invention is directed to a method for designing a medical device comprising a plurality of struts and non-structural elements integral with the struts for delivering a biologically active material to a body tissue of a patient. As explained above, when the struts are placed in a certain geometric pattern, the concentration of a biologically active material at a center of each cell may not reach C_{\min} of the biologically active material. However, the method of the present invention provides a geometric pattern of the struts in which the concentration of a biologically active material above C_{\min} can be

achieved throughout the body tissue to be treated without increasing the concentration at the tissue located adjacent to the struts above C_{\max} .

[0054] In the method of the invention, a preliminary medical device comprising a plurality of struts in a geometric pattern is modified by incorporating non-structural elements to the struts to improve the concentration-profile for the biologically active material released from the device to the body tissue to be treated. Any medical device comprising a plurality of struts in a geometric pattern, such as stent, can be used as a preliminary medical device for the method of the invention provided that the struts comprise a biologically active material.

[0055] In the method of the present invention, a concentration-profile for the biologically active material delivered to the body tissue from the preliminary medical device is determined. From this profile, the areas of tissue in which the concentration of the biologically active material is below C_{\min} can be determined. Such areas are then correlated to the parts of the geometric pattern of the struts of the preliminary medical device that were in contact with or near such areas.

[0056] The determination of such concentration-profile can be conducted by actually measuring concentrations using the biologically active material *in vitro* with a tissue model, which is similar to the body tissue to be treated, such as cannulated animal arteries with surrounding tissue or an artificial tissue, or *in vivo* with an animal model, such as rabbits or pigs. The biologically active material used for the experiment may be labeled with a fluorescence, a radioactive material or dye. Such labeled biologically active material is coated on the medical device, and then the coated medical device is inserted into the tissue model, or artificial tissue, or implanted in an animal. Alternatively, the biologically active material may be detected using standard GLP separation, mass spectroscopy or other direct analytical methods. After insertion, the tissue may be appropriately sectioned, and the concentration-profile for the labeled biologically active material is measured by a means appropriate to the label employed for the experiment. However, a necessary care should be taken that the label would not greatly affect the diffusion of the biologically active material itself.

[0057] However, the concentration-profile may also be determined by mathematical simulation. For example, assuming a simple diffusion model, such simulation can be conducted by using the following conditions and equations:

$$\frac{\partial C}{\partial t} = D_x \left(\frac{\partial^2 C}{\partial x^2} \right) + D_z \left(\frac{\partial^2 C}{\partial z^2} \right)$$

wherein C refers to a concentration of the biologically active material in the body tissue, x refers to a distance from the medical device along x axis which is perpendicular to a boundary between the medical device and the body tissue, z refers to a distance from the medical device along z axis which is parallel to the boundary, D_x refers to a diffusion coefficient of the biologically active material in direction along x axis, D_z refers to a diffusion coefficient of the biologically active material in a direction along z axis. For example, such x axis and z axis are shown in Figs. 1, 2B, 3 and 4B. D_x and D_z can be determined by the experiments using the labeled biologically active material *in vitro* or *in vivo* as described above. $C = 0$ at $t = 0$, wherein boundary conditions are as follows:

- (i) at a common boundary between the struts and the body tissue (at $x = 0$):

$$D_x \frac{\partial C}{\partial x} = h_1(C - C_\Gamma)$$

wherein C_Γ refers to a concentration of the biologically active material in the struts, and h_1 refers to a mass transfer coefficient. Value of h_1 can be determined by the same experiments described above or determined by assumption based on the information known to one skilled in the art;

- (ii) at a boundary between blood flow and the body tissue (at $x = 0$):

$$D_x \frac{\partial C}{\partial x} = h_2(C - 0)$$

wherein h_2 refers to another mass transfer coefficient. Value of h_2 can be determined by the same experiment mentioned above or determined by assumption based on the information known to one skilled in the art;

- (iii) at an adventitial side of vascular wall (at $x = L$):

$$D_x \frac{\partial C}{\partial x} = -h_3(C - 0)$$

wherein h_3 is yet another mass transfer coefficient, and L is a width of a region of interest. Value of h_3 can be determined by the same experiment mentioned above or determined by assumption based on the information known to one skilled in the art; and

- (iv) "symmetry" (no-flux) boundary conditions at certain cross-sections perpendicular to z axis:

$$\frac{\partial C}{\partial z} (z = 0) = \frac{\partial C}{\partial z} (z = L_z) = 0$$

wherein L_z is the length along z axis of a region of interest.

[0058] Although a simplified model based on two diffusion coefficients of the biologically active material in two directions, *i.e.*, depth of the tissue penetration and the distance diffused, is described above as an example, there are more complex models which can be also employed for the method of the present invention. Such complex models may further account for other variables, such as convection, vessel wall inhomogeneties, the type of cells, the lesions, the variabilities brought by different coatings or coating porosity, blood flow, body temperature, blood pressure, and/or pressure of the implant against the vessel wall.

[0059] Subsequent to determining the concentration-profile for the biologically active material which is released from the preliminary medical device, the geometric pattern of the preliminary medical device is modified by incorporating a plurality of non-functional elements that are integral with the struts to achieve more desired distribution of the biologically active material in the body tissue to be treated. The non-structural elements also comprise the biologically active material. For example, the area of tissue in which the concentration of the biologically active material is below C_{\min} is determined from the concentration-profile. Then, it is determined which parts of the geometric pattern of the struts of the preliminary medical device were in contact with or near such areas. The non-structural elements can be incorporated near such parts in the geometric pattern, so that the biologically active material released from the non-structural elements would change the concentration in those areas.

[0060] For example, a stent 10 having a plurality of struts 13 in a conventional geometric pattern in Fig. 1 can be provided as the preliminary medical device. The struts 13 are coated with a biologically active material. Then, a concentration-profile in a body tissue for the biologically active material which is released from the struts 13 is determined. An example of such profile is shown in Figs. 2A and 2B with the cross-sectional views of the stent 10 in the blood vessel 15. The determination of such concentration-profile can be conducted by actually measuring concentrations or by mathematical simulation as mentioned above. According to the obtained concentration-profile, the geometric pattern of the struts 13 of the preliminary stent 10 are modified with non-structural elements 14, for example, as shown in Fig. 3. Figs. 4A and 4B show the concentration-profile views for the biologically active material in the vessel wall 12. When the concentration-profile in the vessel wall 12 to be treated shown in Figs. 2A-B and 4A-B are compared, in Figs. 4A-B, the concentrations generally throughout the entire area of the vessel wall 12 to be treated are above C_{\min} and below C_{\max} . It is clear that the modified stent 10 achieves a more

desirable concentration-profile in the vessel wall 12 to be treated with the biologically active material than the preliminary stent 10.

[0061] Preferably, after a concentration-profile for the biologically active material in the body tissue which is released from the modified preliminary medical device is determined, if there is an area of the body tissue having the local concentration of the biologically active material lower than C_{min} , then the device is modified again by adding non-structural elements to the struts. In addition to or instead of merely adding additional non-structural elements, the non-structural elements which have been already added can be removed or relocated according to the determined concentration-profile. Consequently, a medical device having further improved delivery of the biologically active material is obtained. If necessary, the determination step and the modification step explained above can be repeated as many as possible.

1.3 MEDICAL DEVICE WITH RADially ASYMMETRIC AREA HAVING NON-STRUCTURAL ELEMENTS

[0062] The prior sections (section 1.1 and 1.2) explained how non-structural elements can be added to a preliminary medical device to achieve a more desired concentration-profile for the biologically active material released from the device into body tissue. When the entire outer surface of a medical device, which comprises the plurality of struts and non-structural elements, is used to treat body, the non-structural elements should be positioned uniformly throughout the entire outer surface of the medical device.

[0063] However, if the body tissue to be treated is smaller in surface area than the entire outer surface of the medical device, then the non-structural elements do not have to be positioned throughout the entire surface of the medical device. For example, the medical device can comprise a tubular portion comprising an outer surface, such as a stent, which comprises a plurality of struts and a plurality of non-structural elements. The non-structural elements located in a radially asymmetric distribution, such as shown in Fig. 17 where 33 represents the location of the non-structural element on outer surface of a simplified figure of a stent 32. In this figure, the non-structural elements are distributed only in a rectangular portion of the outer surface. Fig. 18 depicts a perspective view of a stent 34 wherein non-structural elements 36 are provided onto the struts 35 only in a rectangular portion of the outer surface. Such rectangular portion may be parallel to longitudinal axis of the tubular portion and may have the same length as that of the tubular portion. The rectangular portion is preferably from about 25 % to about 75 % of the entire outer surface.

[0064] The present invention is also directed to a method for delivering a biologically active material to body tissue using the above-mentioned medical device,

which comprises a tubular portion comprising an outer surface which comprises a plurality of struts and a plurality of non-structural elements, and the non-structural elements are located in a radially asymmetric distribution on the outer surface. In the method, the medical device is inserted into the body of the patient. Preferably, the non-structural elements are distributed only in a rectangular portion of the outer surface, and the medical device is inserted in such a way that the rectangular portion is in direct contact with the body tissue to be treated. In this way, the body tissue to be treated will receive desired distribution of the biologically active material. On the other hand, the body tissue which does not need to be treated will be exposed to a lesser amount of the biologically active material.

2. INCREASED CAPACITY OF THE END SECTIONS FOR CARRYING OR CONTAINING A BIOLOGICALLY ACTIVE MATERIAL

[0065] In other embodiments of the medical device insertable into the body of a patient of the invention, the medical device comprises an outer surface comprising a plurality of struts, and the end sections of the outer surface have a greater capacity per unit length of the outer surface for carrying or containing a biologically active material than the middle section of the outer surface. Specifically, in one embodiment of the medical device, each strut at the end sections has greater available surface area per unit length of the outer surface than the middle section. In another embodiment, the end sections have a greater affinity for the biologically active material per unit length of the outer surface than the middle section.

[0066] The medical device of the present invention may be manufactured with or without a biologically active material by a manufacturer. When the medical device of the present invention is manufactured without a biologically active material, a practitioner (*e.g.*, a medical doctor or a nurse) can apply the biologically active material to the medical device. In either case, since the end sections of the outer surface have a greater capacity per unit length of the outer surface for carrying or containing the biologically active material than the middle section, the end sections will carry a greater amount of the biologically active material when the biologically active material is applied to the medical device without needing to change application method of the biologically active material to the end sections and the method to the middle section. Therefore, when a practitioner applies to the outer surface of the medical device, such as by dipping, a coating composition containing a biologically active material, a larger amount of the biologically active material per unit length of the outer surface will be deposited at the end sections than the middle section.

[0067] The term "unit length of the outer surface" refers to the length on an imaginary straight line along the outer surface drawn between a point on an edge of the outer surface and another point on the opposing edge of the outer surface. Therefore, the terms, such as "capacity per unit length of the outer surface," "available surface area per unit length of the outer surface," and "amount per unit length of the outer surface," refer respectively to the capacity, available surface area and amount per unit length of the imaginary straight line explained above.

2.1 INCREASED AVAILABLE SURFACE AREA AT THE END SECTIONS

[0068] As explained above, one of the embodiments of the medical device has end sections which have greater available surface area per unit length of the outer surface than that of the middle section. The term "available surface area" refers to a surface area which is available to be coated by a coating composition comprising a biologically active material.

[0069] One way of increasing the available surface area of the end sections is to fabricate the outer surface of the medical device using more material at its ends. For example, when the medical device is comprised of struts, the available surface area per unit length of the outer surface in the end sections is increased by adding non-structural elements to the struts. The non-structural elements are explained above (see section 1.1). The end sections comprise a greater number of the non-structural elements per unit length of the outer surface than the middle section. The middle section may have smaller number of the non-structural elements or no non-structural elements.

[0070] Further, the available surface area can be increased by increasing the surface area of the struts themselves. For example, wavy struts 30 shown in Fig. 15 can have more outer surface area per length than straight struts shown in Fig. 5. Also, struts having greater average diameter, such as struts which are thicker or wider at certain portion 31 shown in Fig. 16, have greater outer surface area per length than struts which have smaller average diameter. Moreover, the end sections of the outer surface can be made to have greater available surface area by roughing the struts' outer surface or providing indentations or grooves on the struts' surface. The above-mentioned wavy struts, wider or thicker struts, indentations and grooves may have various shapes, so long as such structure does not affect stents structural functions. For example, the above-mentioned structure should not hinder self-expansion of a self-expanding stent and should not cause any harm to the patient body. The above-mentioned wavy struts, indentations and grooves can be manufactured by laser ablation.

~~[0071]~~ In another embodiment in which the capacity of the end sections to carry or contain the biologically active material is greater than the capacity of the middle section, the end sections of the outer surface are more porous, and the middle section of the surface is relatively less porous. The middle section may also be non-porous. For example, in Fig. 19, the circles 45 and 47 show enlarged portions of the outer surface of the struts 42 of a stent 40 in the middle section 44 and end section 46, respectively. The surface of the struts in the end section 46 has more pores 48 than the surface of the struts at the middle section 44. In such embodiment, the end sections 46 have a greater available surface area per unit length of the outer surface than that of the middle section 44 since the pores 48 increase available surface area.

[0072] The end sections of the outer surface may be made porous by forming the end sections of the outer surface themselves from a porous material or by forming the end sections with a non-porous material and then covering the end sections with a porous coating layer. For example, porous metal struts can be prepared by sintering metal, *i.e.*, molding or pressing metal particles into a desired shape and heating them to a temperature slightly below the melting point of the metal. Porosity can be changed by using different particle sizes and/or dimensions and/or different temperatures. Also, porous metal struts can be prepared by using metal filaments or fibers. *See e.g.* U.S. Patent No. 5,843,172 issued to Yan which discloses examples of struts made of porous materials, which is incorporated herewith by reference.

[0073] The end sections of the outer surface may be made porous by coating with a porous coating layer. A porous coating layer may be prepared, for example, by applying a mixture of a polymer, an elutable particulate material and a solvent on a surface to form a layer, and then eluting the elutable particulate material from the layer. The following is a detailed description of suitable materials and methods useful in producing a porous coating layer of the invention.

[0074] Polymer(s) useful for forming the porous coating layer should be ones that are biostable, biocompatible, particularly during insertion or implantation of the device into the body and avoids irritation to body tissue. Examples of such polymers include, but not limited to, polyurethanes, polyisobutylene and its copolymers, silicones, and polyesters. Other suitable polymers include polyolefins, polyisobutylene, ethylene-alphaolefin copolymers, acrylic polymers and copolymers, vinyl halide polymers and copolymers such as polyvinyl chloride, polyvinyl ethers such as polyvinyl methyl ether, polyvinylidene halides such as polyvinylidene fluoride and polyvinylidene chloride, polyacrylonitrile, polyvinyl ketones, polyvinyl aromatics such as polystyrene, polyvinyl esters such as

~~polyvinyl acetate, copolymers of vinyl monomers, copolymers of vinyl monomers and~~ olefins such as ethylene-methyl methacrylate copolymers, acrylonitrile-styrene copolymers, ABS resins, ethylene-vinyl acetate copolymers, polyamides such as Nylon 66 and polycaprolactone, alkyd resins, polycarbonates, polyoxyethylenes, polyimides, polyethers, epoxy resins, polyurethanes, rayon-triacetate, cellulose, cellulose acetate, cellulose butyrate, cellulose acetate butyrate, cellophane, cellulose nitrate, cellulose propionate, cellulose ethers, carboxymethyl cellulose, collagens, chitins, polylactic acid, polyglycolic acid, and polylactic acid-polyethylene oxide copolymers. Since the polymer is being applied to a part of the medical device which undergoes mechanical challenges, *e.g.* expansion and contraction, the polymers are preferably selected from elastomeric polymers such as silicones (*e.g.* polysiloxanes and substituted polysiloxanes), polyurethanes, thermoplastic elastomers, ethylene vinyl acetate copolymers, polyolefin elastomers, and EPDM rubbers. The polymer is selected to allow the coating to better adhere to the surface of the expandable portion of the medical device when it is subjected to forces or stress. Furthermore, although the porous coating layer can be formed by using a single type of polymer, various combinations of polymers can be employed.

[0075] The elutable particulate materials which can be incorporated into the polymer include, but not limited to, polyethylene oxide, polyethylene glycol, polyethylene oxide/polypropylene oxide copolymers, polyhydroxyethyl methacrylate, polyvinylpyrrolidone, polyacrylamide and its copolymers, salts, *e.g.*, sodium chloride, sugars, and elutable biologically active materials such as heparin. The amount of elutable particulate material that is incorporated into the polymer should range from about 20% to 90% by weight of the porous coating layer. Furthermore, to increase the porosity of the coating layer applied to the end sections of the surface, a larger amount of the elutable particulate material can be used to form the porous coating layer at the end sections than are used to form the porous coating layer at the middle section. For example, the amount of the elutable particulate material may be from about 0 % to about 40 % for the porous coating layer covering the middle section, and about 50 % to 90% for the porous coating layer covering at the end sections. Also, a more porous coating layer can be realized by using larger average particle size of the elutable material. For example, the particles may have an average particle size from 60-100 microns for porous coating layer covering the end sections and from 0 to about 30 microns for the porous coating layer covering middle section.

[0076] The solvent that is used to form the mixture or slurry of polymer and elutable particulate materials include ones which can dissolve the polymer into solution and do not

alter or adversely impact the therapeutic properties of the biologically active material employed. Examples of useful solvents for silicone include tetrahydrofuran (THF), chloroform and dichloromethane. The composition of polymer and elutable particulate material can be applied to the portion of the medical device in a variety of ways. For example, the composition can be spray-coated onto the device or the device can be dipped into the composition. One of skill in the art would be aware of methods for applying the coating to the device.

[0077] The thickness of the porous coating layer can range from about 25 μm to 0.5 mm. Preferably, the thickness is about 30 μm to 100 μm . After the composition is applied to the device, it should be cured to produce a polymer containing the particulate material and to evaporate the solvent.

[0078] To elute the particulate material from the polymer, a solvent is used. The device can be soaked in the solvent to elute the particulate materials. Other methods of eluting the particulate are apparent to those skilled in the art. The choice of the solvent depends upon the solubility of the elutable particulate material in that solvent. For instance, for water-soluble particulate materials such as heparin, water can be used. For elutable particulate materials that can be dissolved in organic solvents, such organic solvents can be used. Examples of suitable solvents, without limitation, include ethanol, dimethyl sulfoxide, etc.

[0079] Another example of a method for preparing a porous coating is a catalyst-free vapor deposition of a coating composition comprising a polyamide, parylene or a parylene derivative. See U.S. Patent No. 6,299,604 to Ragheb *et al.*, which is incorporated herein by reference.

[0080] In another embodiment of the present invention, the surface including the end sections and middle section are covered with a same porous coating layer composition, but the porous coating layer is thicker at the end sections than at the middle section. For example, a porous coating layer is applied to the entire surface, and then another porous coating layer is applied to the end sections while the middle section is covered by a sheath. The thickness of the porous coating layer at the end sections may be from about 80 μm to about 0.5 mm, and that at the middle section may be from about 10 μm to 40 μm . Since there is more porous coating at the end sections, the end sections of the outer surface should have a greater capacity to carry or contain a biologically active material.

**2.2 THE END SECTIONS WITH GREATER AFFINITY
FOR THE BIOLOGICALLY ACTIVE MATERIAL**

[0081] In another embodiment of the medical device of the present invention, the end sections of the outer surface have a greater affinity for the biologically active material than the middle section. In particular, the end sections comprise a first matrix material and the middle section comprises a second matrix material. The first matrix material has a greater affinity for the biologically active material of interest than the second matrix material so that the end sections can carry or contain a larger amount of the biologically active material per unit length of the outer surface than the middle section. The end sections and the middle section of the outer surface may be formed from the first matrix material and the second matrix material, respectively. Preferably, the end sections of the outer surface and the middle section of the outer surface are formed of another material and then are covered with a coating comprising each of the matrix materials.

[0082] Generally, when a biologically active material used is a hydrophilic, *e.g.*, heparin, then a matrix material comprising a more hydrophilic material has a greater affinity for the biologically active material than another matrix material that is less hydrophilic. When a biologically active material used is a hydrophobic, *e.g.*, paclitaxel, actinomycin, sirolimus (RAPAMYCIN), tacrolimus, everolimus, and dexamethasone, then a matrix material that is more hydrophobic has a greater affinity for the biologically active material than another matrix material that is less hydrophobic.

[0083] Examples of suitable hydrophobic polymers include, but not limited to, polyolefins, such as polyethylene, polypropylene, poly(1-butene), poly(2-butene), poly(1-pentene), poly(2-pentene), poly(3-methyl-1-pentene), poly(4-methyl-1-pentene), poly(isoprene), poly(4-methyl-1-pentene), ethylene-propylene copolymers, ethylene-propylene-hexadiene copolymers, ethylene-vinyl acetate copolymers, blends of two or more polyolefins and random and block copolymers prepared from two or more different unsaturated monomers; styrene polymers, such as poly(styrene), poly(2-methylstyrene), styrene-acrylonitrile copolymers having less than about 20 mole-percent acrylonitrile, and styrene-2,2,3,3,-tetrafluoropropyl methacrylate copolymers; halogenated hydrocarbon polymers, such as poly(chlorotrifluoroethylene), chlorotrifluoroethylene-tetrafluoroethylene copolymers, poly(hexafluoropropylene), poly(tetrafluoroethylene), tetrafluoroethylene, tetrafluoroethylene-ethylene copolymers, poly(trifluoroethylene), poly(vinyl fluoride), and poly(vinylidene fluoride); vinyl polymers, such as poly(vinyl butyrate), poly(vinyl decanoate), poly(vinyl dodecanoate), poly(vinyl hexadecanoate), poly(vinyl hexanoate), poly(vinyl propionate), poly(vinyl octanoate), poly(heptafluoroisopropoxyethylene),

poly(heptafluoroisopropoxypropylene), and poly(methacrylonitrile); acrylic polymers, such as poly(n-butyl acetate), poly(ethyl acrylate), poly(1-chlorodifluoromethyl)tetrafluoroethyl acrylate, poly di(chlorofluoromethyl)fluoromethyl acrylate, poly(1,1-dihydroheptafluorobutyl acrylate), poly(1,1-dihydropentafluoroisopropyl acrylate), poly(1,1-dihydropentadecafluorooctyl acrylate), poly(heptafluoroisopropyl acrylate), poly 5-(heptafluoroisopropoxy)pentyl acrylate, poly 11-(heptafluoroisopropoxy)undecyl acrylate, poly 2-(heptafluoropropoxy)ethyl acrylate, and poly(nonafluoroisobutyl acrylate); methacrylic polymers, such as poly(benzyl methacrylate), poly(n-butyl methacrylate), poly(isobutyl methacrylate), poly(t-butyl methacrylate), poly(t-butylaminoethyl methacrylate), poly(dodecyl methacrylate), poly(ethyl methacrylate), poly(2-ethylhexyl methacrylate), poly(n-hexyl methacrylate), poly(phenyl methacrylate), poly(n-propyl methacrylate), poly(octadecyl methacrylate), poly(1,1-dihydropentadecafluorooctyl methacrylate), poly(heptafluoroisopropyl methacrylate), poly(heptadecafluorooctyl methacrylate), poly(1-hydrotetrafluoroethyl methacrylate), poly(1,1-dihydrotetrafluoropropyl methacrylate), poly(1-hydrohexafluoroisopropyl methacrylate), and poly(t-nonafluorobutyl methacrylate); polyesters, such a poly(ethylene terephthalate) and poly(butylene terephthalate); condensation type polymers such as and polyurethanes and siloxane-urethane copolymers; polyorganosiloxanes, *i.e.*, polymeric materials characterized by repeating siloxane groups, represented by $R_a SiO_{4-a/2}$, where R is a monovalent substituted or unsubstituted hydrocarbon radical and the value of a is 1 or 2; and naturally occurring hydrophobic polymers such as rubber.

[0084] Examples of suitable hydrophilic monomer include, but not limited to, (meth)acrylic acid, or alkaline metal or ammonium salts thereof; (meth)acrylamide; (meth)acrylonitrile; those polymers to which unsaturated dibasic, such as maleic acid and fumaric acid or half esters of these unsaturated dibasic acids, or alkaline metal or ammonium salts of these dibasic adds or half esters, is added; those polymers to which unsaturated sulfonic, such as 2-acrylamido-2-methylpropanesulfonic, 2-(meth)acryloylethanesulfonic acid, or alkaline metal or ammonium salts thereof, is added; and 2-hydroxyethyl (meth)acrylate and 2-hydroxypropyl (meth)acrylate.

[0085] Polyvinyl alcohol is also an example of hydrophilic polymer. Polyvinyl alcohol may contain a plurality of hydrophilic groups such as hydroxyl, amido, carboxyl, amino, ammonium or sulfonyl ($-SO_3$). Hydrophilic polymers also include, but are not limited to, starch, polysaccharides and related cellulosic polymers; polyalkylene glycols and oxides such as the polyethylene oxides; polymerized ethylenically unsaturated carboxylic acids such as acrylic, mathacrylic and maleic acids and partial esters derived from these

acids and polyhydric alcohols such as the alkylene glycols; homopolymers and copolymers derived from acrylamide; and homopolymers and copolymers of vinylpyrrolidone.

[0086] The first matrix material and the second matrix material may be prepared using either a hydrophilic polymer or a hydrophobic polymer, or a blend of a hydrophobic polymer and a hydrophilic polymer in a chosen ratio. For example, when the biologically active material is hydrophilic, then the first matrix material may be prepared by blending from about 55 % to about 100 % hydrophilic polymer and from about 45 % to about 0 % hydrophobic polymer; and the second matrix material may be prepared by blending from about 55 % to about 100 % hydrophobic polymer and from about 45 % to about 0 % hydrophilic polymer. The first matrix material contains a greater amount of the hydrophilic polymer than the second matrix material. When the biologically active material is hydrophobic, then the first matrix material may be prepared by blending from about 55 % to about 95 % hydrophobic polymer and from about 45 % to about 5 % hydrophilic polymer; and the second matrix material may be prepared by blending from about 55 % to about 95 % hydrophilic polymer and from about 45 % to about 5 % hydrophobic polymer. The first matrix material contains a greater amount of the hydrophobic polymer than the second matrix material.

[0087] Again, the outer surface of the medical device of the present invention is, covered with each matrix material, *i.e.*, the end sections with a first matrix material and the middle section with a second matrix material. A first matrix material composition may be prepared and applied by any method to a surface of a medical device to form a coating, such as spraying, dipping, rolling, and electrostatic deposition. Likewise, a second matrix material composition may be prepared and applied by such methods. The first matrix material composition may be applied to the end sections of the outer surface while the middle section is covered to prevent coating the middle section with the first matrix material. Then the second matrix material composition may be applied to the middle section while the end sections are covered. In another embodiment, the second material composition may be applied to the entire outer surface including the middle section and the end sections, then the first matrix material composition may be applied to the end sections while the middle section is covered.

[0088] After the matrix material compositions are applied to the outer surface, the surface should be cured to produce matrix material coatings. The thickness of the matrix material coating can range from about 25 μm to about 0.5 mm. Preferably, the thickness is about 30 μm to 100 μm .

**2.3. THE END SECTIONS WITH GREATER AMOUNT OF
CHEMICAL LINKING MATERIAL TO CARRY OR
CONTAIN THE BIOLOGICALLY ACTIVE MATERIAL**

[0089] In yet another embodiment of the present invention, the capacity of the end sections of the outer surface for carrying or containing a biologically active material can be increased relative to that of the middle section by using an increased amount of chemical linking material to link the biologically active material to the end sections of the outer surface. Specifically, the middle section and end sections of the outer surface are covered with a chemical linking material, and the end sections carry or contain a larger amount of the linking material per unit length of outer surface than the middle section. The chemical linking material allows the biologically active material to attach to the outer surface.

“Linking materials” may be any material which can be coupled to a biologically active material by any bond that are known in the relevant art including, but not limited to, Van der Waals force, ionic bond, covalent bond, hydrogen bond or chemical cross-linking.

[0090] For example, U.S. Patent No. 5,356,433 to Rowland *et al.*, discloses that polysaccharides can be immobilized onto metallic surfaces by applying an organosilane coating with amine functionality and then applying a polysaccharide using carbodiimide as a coupling agent. In the present invention, if the organosilane with amine functionality is used as a linking material, the amount of this material per unit length of the outer surface at the end sections is greater than that at the middle section. In that way, a larger amount of a polysaccharide, which is a biologically active material, can be coupled to the end sections.

[0091] Also, U.S. Patent No. 5,336,518 to Narayanan *et al.* discloses that a polysaccharide can be immobilized on a surface by applying a coat of heptafluorobutylmethacrylate (HFBMA) by radiofrequency (RF) plasma deposition, creating functional groups on the surface by RF plasma with water vapor, and then applying the polysaccharide using carbodiimide. In the present invention, a larger amount of HFBMA, a linking material, is applied to the end sections so that larger amount of a polysaccharide, a biologically active material can be coupled to the HFBMA.

**3. RADIALLY ASYMMETRIC MEDICAL DEVICES HAVING
INCREASED CAPACITY FOR CARRYING OR CONTAINING A
BIOLOGICALLY ACTIVE MATERIAL**

**3.1 MEDICAL DEVICES HAVING NON-STRUCTURAL ELEMENTS
LOCATED IN A RADIALLY ASYMMETRIC DISTRIBUTION**

[0100] As explained above, one way to increase the capacity for carrying or containing a biologically active material of the medical device is to increase available

surface area. In one embodiment of the medical device of the invention, the available surface area is increased in radially asymmetric manner along the entire outer surface, instead of only at the end sections. One such embodiment where the surface area is increased in a radially asymmetric manner by adding non-structural elements to the outer surface (as to non-structural elements, see section 1.3). For example, only a rectangular portion of the outer surface has the non-structural elements. Such rectangular portion may be parallel to longitudinal axis of the tubular portion and may have the same length as that of the tubular portion. The rectangular portion is preferably from about 25 % to about 75 % of the entire outer surface. Please see section 1.3 as to a method for delivering a biologically active material to body tissue using such medical device.

3.2 MEDICAL DEVICE HAVING RADIALLY ASYMMETRIC INCREASED AVAILABLE SURFACE AREA OR AFFINITY

[0101] Another embodiment of the medical device of the invention comprises a tubular portion comprising struts and having an outer surface. A portion of the outer surface has increased available surface or affinity for the biologically active material in such a way that the available surface area or affinity for the biologically active material is radially asymmetric. Please see prior section (section 3.1) as to examples of radially asymmetric distributions. Increased available surface area or increased affinity to the biologically active material can be achieved as explained in the prior sections (sections 2.1 and 2.2). Please see section 1.3 as to a method for delivering a biologically active material to body tissue using such medical device.

4. SUITABLE MEDICAL DEVICES

[0102] The medical devices of the present invention are insertable into the body of a patient. Namely, at least a portion of such medical devices may be temporarily inserted into or semi-permanently or permanently implanted in the body of a patient. Preferably, the medical devices of the present invention comprise a tubular portion which is insertable into the body of a patient. The tubular portion of the medical device need not to be completely cylindrical. For instance, the cross-section of the tubular portion can be any shape, such as a rectangle, a triangle, *etc.*, not just a circle.

[0103] The medical devices suitable for the present invention include, but are not limited to, stents, surgical staples, catheters, such as central venous catheters and arterial catheters, guidewires, balloons, filters (*e.g.*, vena cava filters), cannulas, cardiac pacemaker leads or lead tips, cardiac defibrillator leads or lead tips, implantable vascular access ports, stent grafts, vascular grafts or other grafts, interluminal paving system, intra-aortic balloon

pumps, heart valves, cardiovascular sutures, total artificial hearts and ventricular assist pumps.

[0104] Medical devices which are particularly suitable for the present invention include any kind of stent for medical purposes, which are known to the skilled artisan. Suitable stents include, for example, vascular stents such as self-expanding stents and balloon expandable stents. Examples of self-expanding stents useful in the present invention are illustrated in U.S. Patent Nos. 4,655,771 and 4,954,126 issued to Wallsten and 5,061,275 issued to Wallsten *et al.* Examples of appropriate balloon-expandable stents are shown in U.S. Patent No. 4,733,665 issued to Palmaz, U.S. Patent No. 4,800,882 issued to Gianturco, U.S. Patent No. 4,886,062 issued to Wiktor and U.S. Patent No. 5,449,373 issued to Pinchasik *et al.* A bifurcated stent is also included among the medical devices suitable for the present invention.

[0105] The medical devices suitable for the present invention may be fabricated from polymeric and/or metallic materials. Examples of such polymeric materials include polyurethane and its copolymers, silicone and its copolymers, ethylene vinyl-acetate, poly(ethylene terephthalate), thermoplastic elastomer, polyvinyl chloride, polyolephines, cellulose, polyamides, polyesters, polysulfones, polytetrafluoroethylenes, acrylonitrile butadiene styrene copolymers, acrylics, polyactic acid, polycyclic acid, polycaprolactone, polyacetal, poly(lactic acid), polylactic acid-polyethylene oxide copolymers, polycarbonate cellulose, collagen and chitins. Examples of suitable metallic materials include metals and alloys based on titanium (*e.g.*, nitinol, nickel titanium alloys, thermo-memory alloy materials), stainless steel, platinum, tantalum, nickel-chrome, certain cobalt alloys including cobalt-chromium-nickel alloys (*e.g.*, Elgiloy® and Phynox®) and gold/platinum alloy. Metallic materials also include clad composite filaments, such as those disclosed in WO 94/16646.

[0106] The medical devices suitable for the present invention also have an outer surface, and the outer surface has end sections and middle section. The term “outer surface” refers to a surface of the medical devices which are to be exposed to the body tissue. For example, the tubular structure shown in Fig. 20 is a simplified view of a stent 40. The outer surface of the stent is the surface that is in direct contact with the body tissue when the device is inserted into the body. In the case that the medical device is a stent 40 comprised of struts 42 as shown in Fig. 19, the “outer surface” of the stent refers to the surfaces of the struts which are to directly contact with the body lumen or tissue.

[0107] The term “end section” of the outer surface refers to that part of the surface which extends from an end or edge of the tubular portion up to about 25%, preferably from

about 3% to about 20% of the entire length of the outer surface. For example, when the medical device is a stent 40 as shown in Fig. 19 or 20, the end section 46 of the outer surface is a ring-shape portion extending from the edge of the outer surface of stent having length e , which is up to 25% of the entire length α of the outer surface of stent. In Figs. 19 and 20, the end sections 46 are shown as the shaded portions.

[0108] The term "middle section" refers to the remainder of the outer surface that is surrounded by the end sections as defined above. For example, in Fig. 19 or 20, the middle section 44 is a ring-shape portion having length m , which is surrounded by the end sections.

5. APPLYING BIOLOGICALLY ACTIVE MATERIAL TO THE OUTER SURFACE

[0109] As discussed earlier, the biologically active material can be applied to the embodiments described in sections 2.1 to 2.3 when the device is manufactured or afterwards by a medical professional shortly before the device is inserted into a patient. The biologically active material may be applied to the outer surface of the device obtained as in sections 1.1-1.3, 2.1-2.3 and 3.1-3.2, alone or in conjunction with other materials, such as a polymeric material. For example, in the embodiment where the end sections have a greater available surface area per unit length of the outer surface than the middle section, the biologically active material can be applied to the outer surface in a coating composition containing the biologically active material and a polymeric material. Specifically, a coating composition of biologically active material and polymeric material can be prepared and then applied to the outer surface. However, the biologically active material alone can also be applied to the outer surface of this embodiment.

[0110] In the embodiments where a portion of the outer surface has a greater affinity for the biologically active material or where a portion of the outer surface contains more chemical liking material, the biologically active material is preferably applied alone to the outer surface. For instance, in the embodiment having a matrix material with greater affinity for the biologically active material in a portion of the outer surface, the biologically active material can be applied to the matrix material coatings on the outer surface. However, the biologically active material can also be applied to the material along with a polymeric material. Also, the biologically active material can be incorporated into the matrix material coating compositions to form matrix material coatings already containing the biologically active material.

5.1 COATING COMPOSITIONS AND COATING LAYERS

[0111] The coating compositions suitable for the present invention can be applied by any method to a surface of a medical device to form a coating. Examples of such methods are spraying, dipping, rolling, electrostatic deposition and all modern chemical ways of immobilization of bio-molecules to surfaces.

[0112] The coating composition used in the present invention may be a solution of a biologically active material in an aqueous or organic solvent. Such coating composition may be applied to a surface, and the solvent may be evaporated. A biologically active material solution may be used when the tubular portion of the medical device has end sections having increased surface area or increased affinity as explained above, especially when the end sections are porous.

[0113] Furthermore, coating compositions useful for the present invention may include a polymeric material and optionally a biologically active material dispersed or dissolved in a solvent suitable for the medical device which is known to the skilled artisan. The solvents used to prepare coating compositions include ones which can dissolve the polymeric material into solution and do not alter or adversely impact the therapeutic properties of the biologically active material employed. For example, useful solvents for silicone include tetrahydrofuran (THF), chloroform, toluene, acetone, isooctane, 1,1,1-trichloroethane, dichloromethane, and a mixture thereof.

[0114] A coating of a medical device of the present invention may consist of various kinds of combination of multiple coating layers. For example, the first layer and the second layer may contain different biologically active materials. Alternatively, the first layer and the second layer may contain an identical biologically active material having different concentrations. In one embodiment, either of the first layer or the second layer may be free of biologically active material. For example, when the biologically active solution is applied onto a surface and dried (the first layer), a coating composition free of a biologically active material (the second layer) can be applied over the dried biologically active material.

[0115] The polymeric material should be a material that is biocompatible and avoids irritation to body tissue. Examples of the polymeric materials used in the coating composition of the present invention include, but not limited to, polycarboxylic acids, cellulosic polymers, including cellulose acetate and cellulose nitrate, gelatin, polyvinylpyrrolidone, cross-linked polyvinylpyrrolidone, polyamides including maleic anhydride polymers, polyamides, polyvinyl alcohols, copolymers of vinyl monomers such as EVA, polyvinyl ethers, polyvinyl aromatics, polyethylene oxides, glycosaminoglycans,

polysaccharides, polyesters including polyethylene terephthalate, polyacrylamides, polyethers, polyether sulfone, polycarbonate, polyalkylenes including polypropylene, polyethylene and high molecular weight polyethylene, halogenated polyalkylenes including polytetrafluoroethylene, polyurethanes, polyorthoesters, proteins, polypeptides, silicones, siloxane polymers, polylactic acid, polyglycolic acid, polycaprolactone, polyhydroxybutyrate valerate, styrene-isobutylene copolymers and blends and copolymers thereof. Also, other examples of such polymers include polyurethane (BAYHDROL®, etc.) fibrin, collagen and derivatives thereof, polysaccharides such as celluloses, starches, dextrans, alginates and derivatives, hyaluronic acid, and squalene. Further examples of the polymeric materials used in the coating composition of the present invention include other polymers which can be used include ones that can be dissolved and cured or polymerized on the medical device or polymers having relatively low melting points that can be blended with biologically active materials. Additional suitable polymers include, thermoplastic elastomers in general, polyolefins, polyisobutylene, ethylene-alphaolefin copolymers, acrylic polymers and copolymers, vinyl halide polymers and copolymers such as polyvinyl chloride, polyvinyl ethers such as polyvinyl methyl ether, polyvinylidene halides such as polyvinylidene fluoride and polyvinylidene chloride, polyacrylonitrile, polyvinyl ketones, polyvinyl aromatics such as polystyrene, polyvinyl esters such as polyvinyl acetate, copolymers of vinyl monomers, copolymers of vinyl monomers and olefins such as ethylene-methyl methacrylate copolymers, acrylonitrile-styrene copolymers, ABS (acrylonitrile-butadiene-styrene) resins, ethylene-vinyl acetate copolymers, polyamides such as Nylon 66 and polycaprolactone, alkyd resins, polycarbonates, polyoxymethylenes, polyimides, epoxy resins, rayon-triacetate, cellulose, cellulose acetate, cellulose butyrate, cellulose acetate butyrate, cellophane, cellulose nitrate, cellulose propionate, cellulose ethers, carboxymethyl cellulose, collagens, chitins, polylactic acid, polyglycolic acid, polylactic acid-polyethylene oxide copolymers, EPDM (ethylene-propylene-diene) rubbers, fluorosilicones, polyethylene glycol, polysaccharides, phospholipids, and combinations of the foregoing.

[0116] Preferred is polyacrylic acid, available as HYDROPLUS® (Boston Scientific Corporation, Natick, Mass.), and described in U.S. Pat. No. 5,091,205, the disclosure of which is hereby incorporated herein by reference. In a most preferred embodiment of the invention, the polymer is a copolymer of polylactic acid and polycaprolactone.

[0117] More preferably for medical devices which undergo mechanical challenges, e.g. expansion and contraction, the polymeric materials should be selected from elastomeric

polymers such as silicones (e.g. polysiloxanes and substituted polysiloxanes), polyurethanes, thermoplastic elastomers, ethylene vinyl acetate copolymers, polyolefin elastomers, and EPDM rubbers. Because of the elastic nature of these polymers, the coating composition adheres better to the surface of the medical device when the device is subjected to forces, stress or mechanical challenge.

[0118] A controlled-release coating of a biologically active material may be prepared by a coating composition comprising an appropriate hydrophobic polymer. For example, a controlled-release coating may comprise a coating layer containing a biologically active material and a top coating layer comprising a hydrophobic polymer. Also, a controlled-release coating may be prepared from a coating composition containing a mixture of a hydrophobic polymer and a biologically active material.

[0119] The amount of the polymeric material present in the coatings can vary based on the application for the medical device. One skilled in the art is aware of how to determine the desired amount and type of polymeric material used in the coating. The thickness of the coating is not limited, but generally ranges from about 25 μm to about 0.5 mm. Preferably, the thickness is about 30 μm to 100 μm .

5.2 SUITABLE BIOLOGICALLY ACTIVE MATERIAL

[0120] The term "biologically active material" encompasses therapeutic agents, such as drugs, and also genetic materials and biological materials. The genetic materials mean DNA or RNA, including, without limitation, of DNA/RNA encoding a useful protein stated below, anti-sense DNA/RNA, intended to be inserted into a human body including viral vectors and non-viral vectors. Examples of DNA suitable for the present invention include DNA encoding:

- anti-sense RNA;
- tRNA or rRNA to replace defective or deficient endogenous molecules;
- angiogenic factors including growth factors, such as acidic and basic fibroblast growth factors, vascular endothelial growth factor, epidermal growth factor, transforming growth factor α and β , platelet-derived endothelial growth factor, platelet-derived growth factor, tumor necrosis factor α , hepatocyte growth factor and insulin like growth factor;
- cell cycle inhibitors including CD inhibitors;
- thymidine kinase ("TK") and other agents useful for interfering with cell proliferation; and
- the family of bone morphogenic proteins ("BMP's") as explained below.

Viral vectors include adenoviruses, gutted adenoviruses, adeno-associated virus, retroviruses, alpha virus (Semliki Forest, Sindbis, etc.), lentiviruses, herpes simplex virus, ex vivo modified cells (*e.g.*, stem cells, fibroblasts, myoblasts, satellite cells, pericytes, cardiomyocytes, skeletal myocytes, macrophage), replication competent viruses (*e.g.*, ONYX-015), and hybrid vectors. Non-viral vectors include artificial chromosomes and mini-chromosomes, plasmid DNA vectors (*e.g.*, pCOR), cationic polymers (*e.g.*, polyethyleneimine, polyethyleneimine (PEI)) graft copolymers (*e.g.*, polyether-PEI and polyethylene oxide-PEI), neutral polymers PVP, SP1017 (SUPRATEK), lipids or lipoplexes, nanoparticles and microparticles with and without targeting sequences such as the protein transduction domain (PTD).

[0121] The biological materials include cells, yeasts, bacteria, proteins, peptides, cytokines and hormones. Examples for peptides and proteins include growth factors (FGF, FGF-1, FGF-2, VEGF, Endothelial Mitogenic Growth Factors, and epidermal growth factors, transforming growth factor α and β , platelet derived endothelial growth factor, platelet derived growth factor, tumor necrosis factor α , hepatocyte growth factor and insulin like growth factor), transcription factors, protein kinases, CD inhibitors, thymidine kinase, and bone morphogenic proteins (BMP's), such as BMP-2, BMP-3, BMP-4, BMP-5, BMP-6 (Vgr-1), BMP-7 (OP-1), BMP-8, BMP-9, BMP-10, BMP-11, BMP-12, BMP-13, BMP-14, BMP-15, and BMP-16. Currently preferred BMP's are BMP-2, BMP-3, BMP-4, BMP-5, BMP-6, BMP-7. Alternatively or in addition, molecules capable of inducing an upstream or downstream effect of a BMP can be provided. Such molecules include any of the "hedgehog" proteins, or the DNA's encoding them. These dimeric proteins can be provided as homodimers, heterodimers, or combinations thereof, alone or together with other molecules. Cells can be of human origin (autologous or allogeneic) or from an animal source (xenogeneic), genetically engineered, if desired, to deliver proteins of interest at the transplant site. The delivery media can be formulated as needed to maintain cell function and viability. Cells include whole bone marrow, bone marrow derived mono-nuclear cells, progenitor cells (*e.g.*, endothelial progenitor cells), stem cells (*e.g.*, mesenchymal, hematopoietic, neuronal), pluripotent stem cells, fibroblasts, macrophage, and satellite cells.

[0122] Biologically active material also includes non-genetic therapeutic agents, such as:

- anti-thrombogenic agents such as heparin, heparin derivatives, urokinase, and PPACK (dextrophenylalanine proline arginine chloromethylketone);

- anti-proliferative agents such as enoxaprin, angiopeptin, or monoclonal antibodies capable of blocking smooth muscle cell proliferation, hirudin, and acetylsalicylic acid, tacrolimus, everolimus, amlodipine and doxazosin;
- anti-inflammatory agents such as glucocorticoids, betamethasone, dexamethasone, prednisolone, corticosterone, budesonide, estrogen, sulfasalazine, rosiglitazone, mycophenolic acid, and mesalamine;
- immunosuppressants such as sirolimus (RAPAMYCIN), tacrolimus, everolimus and dexamethasone;
- antineoplastic/antiproliferative/anti-miotoxic agents such as paclitaxel, 5-fluorouracil, cisplatin, vinblastine, cladribine, vincristine, epothilones, methotrexate, azathioprine, halofuginone, adriamycin, actinomycin and mutamycin; endostatin, angiostatin and thymidine kinase inhibitors, and its analogs or derivatives;
- anesthetic agents such as lidocaine, bupivacaine, and ropivacaine;
- anti-coagulants such as D-Phe-Pro-Arg chloromethyl ketone, an RGD peptide-containing compound, heparin, antithrombin compounds, platelet receptor antagonists, anti-thrombin antibodies, anti-platelet receptor antibodies, aspirin (aspirin is also classified as an analgesic, antipyretic and anti-inflammatory drug), dipyridamole, protamine, hirudin, prostaglandin inhibitors, platelet inhibitors and antiplatelet agents such as trapidil or liprostin, tick antiplatelet peptides;
- DNA demethylating drugs such as 5-azacytidine, which is also categorized as a RNA or DNA metabolite that inhibit cell growth and induce apoptosis in certain cancer cells;
- vascular cell growth promoters such as growth factors, Vascular Endothelial Growth Factors (VEGF, all types including VEGF-2), growth factor receptors, transcriptional activators, and translational promoters;
- vascular cell growth inhibitors such as antiproliferative agents, growth factor inhibitors, growth factor receptor antagonists, transcriptional repressors, translational repressors, replication inhibitors, inhibitory antibodies, antibodies directed against growth factors, bifunctional molecules consisting of a growth factor and a cytotoxin, bifunctional molecules consisting of an antibody and a cytotoxin;
- cholesterol-lowering agents; vasodilating agents; and agents which interfere with endogenous vasoactive mechanisms;
- anti-oxidants, such as probucol;
- antibiotic agents, such as penicillin, cefoxitin, oxacillin, tobramycin;

- angiogenic substances, such as acidic and basic fibroblast growth factors, estrogen including estradiol (E2), estriol (E3) and 17-Beta Estradiol;
- drugs for heart failure, such as digoxin, beta-blockers, angiotensin-converting enzyme (ACE) inhibitors including captopril and enalapril, statins and related compounds; and
- macrolides such as sirolimus or everolimus.

[0123] Also, the biologically active materials of the present invention include nitric oxide adducts, which prevent and/or treat adverse effects associated with use of a medical device in a patient, such as restenosis and damaged blood vessel surface. Typical nitric oxide adducts include nitroglycerin, sodium nitroprusside, S-nitroso-proteins, S-nitroso-thiols, long carbon-chain lipophilic S-nitrosothiols, S-nitrosodithiols, iron-nitrosyl compounds, thionitrates, thionitrites, sydnonimines, furoxans, organic nitrates, and nitrosated amino acids, preferably mono-or poly-nitrosylated proteins, particularly polynitrosated albumin or polymers or aggregates thereof. The albumin is preferably human or bovine, including humanized bovine serum albumin. Such nitric oxide adducts are disclosed in U.S. Patent No. 6,087,479 to Stamler *et al.* which is incorporated herein by reference.

[0124] In addition, biologically active materials include anti-proliferative drugs such as steroids, vitamins, and restenosis-inhibiting agents. Preferred restenosis-inhibiting agents include microtubule stabilizing agents such as Taxol, paclitaxel, paclitaxel analogues, derivatives, and mixtures thereof. For example, derivatives suitable for use in the present invention include 2'-succinyl-taxol, 2'-succinyl-taxol triethanolamine, 2'-glutaryl-taxol, 2'-glutaryl-taxol triethanolamine salt, 2'-O-ester with N-(dimethylaminoethyl) glutamine, and 2'-O-ester with N-(dimethylaminoethyl) glutamide hydrochloride salt. Other preferred biologically active materials include nitroglycerin, nitrous oxides, nitric oxides, antibiotics, aspirins, digitalis, estrogen derivatives such as estradiol and glycosides. A biologically active material may be encapsulated in micro-capsules by the known methods.

5.3 MEDICAL DEVICES WITH END SECTIONS THAT CARRY OR CONTAIN A GREATER AMOUNT OF BIOLOGICALLY ACTIVE MATERIAL THAN THE MIDDLE SECTION

[0125] In another embodiment of the invention, a more uniform release-profile for a biologically active material along the length of the outer surface of the medical device may be achieved by preparing a medical device having end sections that carry or contain a greater amount of a biologically active material than the middle section.

[0126] In section 2, supra, the medical devices of the present invention having end sections that have increased capacity for carrying or containing a biologically active material were explained. When a coating composition comprising the biologically active material is applied to such medical devices by a conventional method, such as spraying, dipping, rolling, and electrostatic deposition, the end sections will carry or contain a greater amount of the biologically active material per unit length of the outer surface than the middle section of the outer surface.

[0127] However, greater amounts of biologically active material at the end sections can also be achieved by controlling the amount of the biologically active material that is applied to the middle and end sections. For instance, additional coating composition containing a biologically active material can be applied to the end sections so that such sections have a thicker coating and hence contain more biologically active material. A method for preparing such medical device comprises, for example, applying a first coating composition containing a biologically active material to the end sections and a middle section of an outer surface, placing a cover over the middle section, applying more of the first coating composition or second coating composition to the end sections of the outer surface. The second coating composition may contain the same biologically active material as the first coating composition having the same or different concentration or may contain a different biologically active material.

[0128] Another example of a method useful in allowing more biologically active material to the end sections relative to the middle section involves covering the middle section. In particular, a coating composition containing the desired biologically active material is applied to the middle section and end sections. The middle section is then covered by a sheath or mesh. Such covering can be achieved also by masking using photolithography techniques. Additional coating composition is then applied to the end sections. The covering prevents such additional coating composition from being applied to the middle section so that the end sections will contain relatively more biologically active material.

[0129] In yet another embodiment of the medical device of the present invention, a greater amount of the biologically active material can be applied to the end sections by applying coating compositions having different concentration of the first biologically active material to the middle and end sections. For example, applying a coating composition containing a first concentration of a biologically active material is applied to the end sections while the middle section is covered. Thereafter, a second coating composition having a second concentration of the biologically active material, which is smaller than the

first concentration to the middle section. The sections may be covered using sheaths or masking as explained above.

5.4 MEDICAL DEVICE COMPRISING A BIOLOGICALLY ACTIVE MATERIAL IN A RADIALY ASYMMETRIC DISTRIBUTION

[0130] Yet another embodiment of the medical device of the invention achieves a greater amount of release of a biologically active material to a necessary body tissue. Such medical device comprises an outer surface comprising the biologically active material in a radially asymmetric distribution. For example, a rectangular portion of the outer surface has a greater amount of the biologically active material than the rest of the outer surface. When the medical device comprises a tubular portion, the rectangular portion may be parallel to longitudinal axis of the tubular portion. The rectangular portion may be the same length as that of the tubular portion. A greater amount of the biologically active material can be distributed to a rectangular portion using any of the manners used to distribute a greater amount of the biologically active material to the end sections (see section 5.3, *supra*).

6. BARRIER LAYER OVER THE MIDDLE SECTION

[0131] In yet another embodiment, there is a barrier layer placed over the middle section of the outer surface, so that the end sections of the outer surface are allowed to release greater amounts of the biologically active material relative to the middle section. The middle and end sections are covered with a coating composition containing biologically active material. A covering or barrier layer is then placed over the middle section to limit the release of the biologically active material. In this way, the release ratio of biologically active material from the end sections is relatively greater than from the middle section.

[0132] Examples of such barrier layers include, but not limited to, a top-coating layer covering the middle section. When the medical device of the present invention is a stent, examples of such barrier layers include, but not limited to, a sheath with or without apertures or openings. Suitable material for making such barrier layer include, but not limited to, hydrophobic polymers listed in section 2.2, *supra*.

7. EXPANDABLE STENTS HAVING PROJECTING ELEMENTS AT THEIR ENDS

[0133] Another embodiment of the present invention is directed to an expandable stent, such as a balloon-expandable stent having two ends or edges and a tubular sidewall in between the ends. The tubular sidewall comprises a plurality of struts. The stent also

comprises a plurality of projecting elements located at or proximate the ends or edges of the stent in its unexpanded state. Each projecting element has two ends. One end of the projecting element is attached to or integral with a stent strut. When the stent is expanded to an expanded state, the end of the projecting element that is not attached to or integral with a stent strut defines the end or edge of the expanded stent. Also, the end of the unattached projecting element can define the end or edge of the stent in both its expanded and unexpanded state.

[0134] Fig. 21 shows an example of such a stent 210 in its unexpanded state. The stent 210 comprises two stent ends or edges 211a and 211b with a tubular sidewall 212 therebetween. The tubular sidewall 212 comprises or is made up of a plurality of struts 214. In this stent 210 the struts 214 are arranged as a plurality of valleys 214a and apexes 214b. The sidewall comprises a plurality of projecting elements 215, each having two ends 215a and 215b. The projecting elements are located proximate at least one stent end 211a and/or 211b. One end of the projecting element, e.g. a first projecting element end 215a, is attached to or integral with a stent strut 214. Although this figure shows that the first projecting element end 215a is attached to or integral with a stent strut that forms a valley 214a, the first projecting element end 215a can be attached to or integral with a stent strut that forms an apex 214b.

[0135] Fig. 22 shows the stent 210 of Fig. 21 in its expanded state. When the stent 210 is expanded, or in an expanded state the projecting element ends 215b that are not attached to or integral with a stent strut (e.g. the second projecting element ends) are capable of defining at least one end or edge 211a and/or 211b of the stent 210. Preferably the second projecting element ends 215b can define the stent end(s) 211a and/or 211b when the stent is in its fully expanded state; however the projecting element ends 215b can define the stent end(s) 211a and/or 211b when the stent is in a partially expanded state that is less than the fully expanded state.

[0136] The projecting elements 215 should have substantially no effect on the expansion of the stent. Moreover, the projecting elements do not radially expand when the stent is radially expanded. More specifically, with reference to Figs. 21 and 22, when the stent is radially expanded, apex 214b will radially expand and change in height or length from L to L', which is less than L. However, because of the configuration of the projecting element 215, the projecting element will not expand in width w when the stent is expanded, i.e., the width w of the projecting element does not change or increase when the stent is radially expanded. Also, the projecting element does not change length when the stent is

radially expanded. By not expanding in width when the stent expands, the projecting element acts as a source of stress relief.

[0137] Furthermore, the projecting elements 215, shown in Figures 21 and 22 function as sources of stress relief because they are not supported at their sides as the apices 214b are. The projecting elements are supported at only one point 215c (Fig. 22) by a stent strut, *i.e.*, the projecting element is attached or integral with a stent strut only at a single point of the projecting. In contrast the apices are supported by stent struts at two points 215c and 215d (in Fig. 22). The amount of support from adjacent struts can affect the strain at the end of a stent. Also, extension of the projecting elements 215 longitudinally beyond the apices of the expanded stent act to relieve the strain. By extending further longitudinally toward the edge of the stent than the apices, the projecting elements apply less force to the vessel than the apices. This creates a region of lower stress between the apices and native vessel beyond the end of the projecting elements.

[0138] Also, the projecting elements preferably lie along substantially the same plane as the struts of the stent. This way, at least a portion of each projecting element contacts a patient's lumen wall like the stent struts when the stent is placed in a body lumen. In embodiments of the expandable stent of the present invention, the projecting elements are preferably integral with the struts, namely, they are generally made from the same material as the struts and are formed as a continuous part of the struts. However, the struts and projecting elements can be made of different types of materials and are then connected or attached to each other. Preferably, the projecting elements and struts may be manufactured simultaneously; for example, struts having projecting elements can be laser-ablated from a plate of metal or polymer. In other embodiments the projecting elements may be attached to the stent struts after the stent is formed.

[0139] The projecting elements may be integral with or attached to struts at any portion proximate the ends of the unexpanded stent so long as the projecting elements do not hinder the stent from collapsing and expanding. When the struts are configured as a plurality of apices and valleys, the projecting elements may be integral with or attached to struts at apices, valleys or anywhere in between. For example, Fig. 21 shows a stent in its collapsed or unexpanded state, wherein the stent has projecting elements 215 integral with a strut forming a valley 214a. Figs. 23-27a show ends of stents, wherein the projecting elements 230, 240, 250, 260, 260a, 270 and 270a are integral with or attached to struts forming apices 214b. The projecting elements can be distributed uniformly or in any other manner proximate the ends of the stent.

[0140] The projecting elements suitable for the present invention may be in any shape including a straight rod, a bent rod, a rod having a greater width at the projecting elements free end (*e.g.*, *see* Figs. 22, 23, 24 and 27), a rod having a hoop or circle or sphere at the free end (*e.g.*, *see* Figs. 26 and 26a), a truncated circle or cone (*e.g.*, *see* Fig. 25). Moreover, the projecting elements can have a serpentine-like or spiral-like shape as shown in Fig. 27a. Also, as shown, *e.g.*, in Fig. 27, the length of the projecting elements 270 may vary. Also, as shown in Fig. 27, the free ends of the projecting elements not only define the ends of the stent in its expanded state but can also define the stent ends when the stent is in its unexpanded state.

[0141] The stent struts 214 may be fabricated from metallic and/or polymeric materials. Suitable metallic materials include metals and alloys based on titanium (such as nitinol, nickel titanium alloys, thermo-memory alloy materials), stainless steel, tantalum, nickel-chrome, or certain cobalt alloys including cobalt-chromium-nickel alloys such as Elgiloy® and Phynox®. Metallic materials also include clad composite filaments, such as those disclosed in WO 94/16646. Suitable polymeric materials include without limitation polyurethane and its copolymers, silicone and its copolymers, ethylene vinyl-acetate, polyethylene terephthalate, thermoplastic elastomers, polyvinyl chloride, polyolefins, cellulose, polyamides, polyesters, polysulfones, polytetrafluoroethylenes, polycarbonates, acrylonitrile butadiene styrene copolymers, acrylics, polylactic acid, polyglycolic acid, polycaprolactone, polylactic acid-polyethylene oxide copolymers, cellulose, collagens, and chitins.

[0142] The projecting elements suitable for the present invention may or may not comprise the same material as the stent struts. In some embodiments, it is preferable that the projecting elements are made from materials that are more flexible than the materials used to form the struts. When the projecting elements are more flexible than the struts, the strain exerted by the stent end against a body lumen, when the stent is in an expanded state, is reduced thereby reducing the possibility of restenosis that may occur at or near the implanted stent ends. More specifically, it has been hypothesized that the restenosis which can occur at or near the ends or edges of a stent implanted in a body lumen, may be caused by a lack of strain relief at or near the ends of the stent. It is believed that the stent struts at the ends of the stent exert too great a pressure against the body tissue that contacts the stent end. Therefore it is desirable to reduce the pressure exerted against the body tissue by the stent ends. The inclusion of projecting elements, whose free ends define the ends of the stent when the stent is in an expanded state, reduces the pressure or strain exerted by the ends of the expanded stent. One way that the use of projecting elements reduces such

pressure or strain is by reducing the amount of stent material present at the ends of the expanded stent. Also, the projecting element may be configured in a shape more flexible than the struts, *e.g.*, thinner and/or narrower than the struts. In this way, the projecting elements avoid the stress to be concentrated at the edges or ends of the stent and reduce the "edge effect."

[0143] As shown in Fig. 22, by including projecting elements 215, the stent end 211b, which is defined by the free end or second end of the projecting elements 215b, is located at line a-a. If the projecting elements 215 were not included as a part of the stent the end of the expanded stent would be located at line b-b. As can be seen in Fig. 22, the amount of stent material at line a-a is less than at line b-b. Thus, inclusion of the projecting elements also reduces the amount of stent material at the stent ends, thereby reducing the pressure exerted by the stent ends against the body tissue. In addition to the amount of stent material, as discussed above, the amount of support from adjacent struts as well as the thickness of the strut impact the strain at the end of a stent.

[0144] Furthermore, making the projecting element from materials that are more flexible than the materials used to make the stent struts also reduces the pressure exerted by the ends of an expanded stent against body tissue. The use of more flexible material for the projecting elements, whose free end defines the end(s) of the expanded stent, allows the stent to have more "give", thereby reducing the pressure the stent end exerts against body tissue when the stent is implanted in a body lumen.

[0145] In a preferred embodiment, at least one strut and/or at least one projecting element comprises a biologically active material. Suitable biologically active materials are discussed above in Section 5.2. The strut or projecting element can be coated with the biologically active material. The coating can further include polymeric materials. Suitable polymeric materials are set forth above in Section 5.1. Alternatively, the biologically active material can be incorporated into the materials used to form the struts or projecting elements such as a polymer having a biologically active material incorporated therein. Moreover, as shown in Figs. 23 and 24 the projecting elements 230 and 240 can be the shape of a rod having an end with a greater width at the second projecting end and at least one depression or indentation 231 and 241, respectively which contains the biologically active material 232. The depressions can also include a polymeric material in addition to the biologically active material. The indentations can be in the shape of cavities that can extend partly or entirely through the projecting element.

[0146] In another embodiment, as shown, *e.g.*, in Figs. 28 and 29 the projecting elements 280 have openings 281. Fig. 28 shows stent end 211b when the stent is

unexpanded. Fig. 29 shows the stent end 211b when the stent is expanded. A ribbon 282 can be passed or threaded through the openings 281. The ribbon 282 contains a biologically active material. The ribbon may or may not be elastic as long as it does not substantially hinder the stent from expanding. The ribbon may be a tape and/or a fabric comprising a polymeric material. Suitable polymeric materials for making the ribbon include without limitation polyurethane and its copolymers, silicone and its copolymers, ethylene vinyl-acetate, polyethylene terephthalate, thermoplastic elastomers, polyvinyl chloride, polyolefins, cellulotics, polyamides, polyesters, polysulfones, polytetrafluorethylenes, polycarbonates, acrylonitrile butadiene styrene copolymers, acrylics, polylactic acid, polyglycolic acid, polycaprolactone, polylactic acid-polyethylene oxide copolymers, cellulose, collagens, and chitins. In some embodiments, the biologically active material is coated on the ribbon. The coating can be applied onto the ribbon in any method, for example, dipping, spraying, electrostatic deposition and rolling. In other embodiments, the ribbon is prepared by soaking a fabric ribbon in a biologically active material solution. In addition, the struts and/or projecting elements can include a biologically active material, such as a coating comprising a biologically active material.

[0147] The description contained herein is for purposes of illustration and not for purposes of limitation. Changes and modifications may be made to the embodiments of the description and still be within the scope of the invention. Furthermore, obvious changes, modifications or variations will occur to those skilled in the art. Also, all references cited above are incorporated herein, in their entirety, for all purposes related to this disclosure.

CLAIMS

We claim:

1. An expandable stent comprising two ends and a tubular sidewall between the two ends,
wherein the sidewall comprises a plurality of struts, and a plurality of projecting elements located proximate at least one stent end;
wherein each projecting element comprises a first end and a second end;
wherein the first projecting element end is integral with or attached to a strut;
wherein the second projecting element end is capable of defining at least one stent end when the stent is in an expanded position; and
wherein at least one of the struts or at least one of the projecting elements comprises a biologically active material.
2. The stent of claim 1 wherein the projecting element is configured such that the projecting element does not expand in width when the stent is radially expanded.
3. The stent of claim 1 wherein the projecting element is integral with or attached to a single strut only at a single point on the projecting element.
4. The stent of claim 1 wherein at least one strut and at least one projecting element comprise the biologically active material.
5. The stent of claim 1 wherein all of the struts and all of the projecting elements comprise the biologically active material.
6. The stent of claim 1 wherein the first projecting element end is integral with the strut.
7. The stent of claim 1 wherein the strut or projecting element that comprises the biologically active material comprises a coating containing the biologically active material.

8. The stent of claim 7 wherein the coating further comprises a polymeric material.
9. The stent of claim 1 wherein the biologically active material is a macrolide selected from sirolimus or everolimus.
10. The stent of claim 1 wherein the biologically active material is selected from paclitaxel, a derivative of paclitaxel or an analog of paclitaxel.
11. The stent of claim 1, wherein at least one projecting element is configured in a shape selected from a straight rod, a bent rod, a rod having an end with a greater width at the second projecting element end, a rod having a hoop at the second projecting element end, or a truncated circle.
12. The stent of claim 1, wherein at least one projecting element is configured in a shape of a rod having an end with a greater width at the second projecting element end, and at least one indentation for containing the biologically active material located at the second projecting element end.
13. The stent of claim 1, wherein at least some of the projecting elements comprise an opening therein and wherein the stent further comprises a ribbon comprising the biologically active material, and wherein the ribbon passes through at least one of the openings in the projecting elements.
14. The stent of claim 1, wherein the projecting elements are distributed uniformly at the ends of the stent.
15. The stent of claim 1, wherein the struts are configured as a plurality of apexes and valleys, and wherein the projecting elements are integral with or attached to at least one of the apexes.
16. The stent of claim 1, wherein the struts are configured as a plurality of apexes and valleys, and wherein the projecting elements are integral with or attached to at least one of the valleys.

17. The stent of claim 1, wherein the struts and the projecting elements comprise the same material.

18. The stent of claim 1, wherein the struts comprise a first material and the projecting elements comprise a second material.

19. The stent of claim 18, wherein the second material is more flexible than the first material.

20. A balloon expandable stent comprising two ends and a tubular sidewall between the two ends, wherein the sidewall comprises a plurality of struts; and a plurality of projecting elements proximate at least one stent end; and

wherein each projecting element comprises a first end and a second end; and wherein the first projecting element end is integral with or attached to a strut; and wherein the second projecting element end is capable of defining at least one stent end when the stent is in an expanded position; and

wherein at least one of the projecting elements comprise a biologically active material.

21. The stent of claim 20 wherein the projecting element is configured such that the projecting element does not expand in width when the stent is radially expanded.

22. The stent of claim 20 wherein the projecting element is integral with or attached to a single strut only at a single point on the projecting element.

23. The stent of claim 20 wherein at least one strut comprises the biologically active material.

24. The stent of claim 20 wherein at least one projecting element comprises a coating comprising the biologically active material.

25. The stent of claim 20 wherein all of the struts and the projecting elements comprise a coating comprising the biologically active material.

26. The stent of claim 20 wherein the biologically active material is selected from paclitaxel, a derivative of paclitaxel or an analog of paclitaxel.

27. A system comprising a balloon expandable stent and a balloon catheter having an inflatable balloon for expanding the stent to an expanded position, wherein the stent comprises two ends and a tubular sidewall between the two ends, wherein the sidewall comprises a plurality of struts; and a plurality of projecting elements proximate at least one stent end; wherein each projecting element comprises a first end and a second end; and wherein the first projecting element end is integral with or attached to a strut; and wherein the second projecting element end is capable of defining at least one stent end when the stent is in the expanded position; wherein at least one of the struts or one of the projecting elements comprise a biologically active material.

28. The stent of claim 27 wherein the projecting element is configured such that the projecting element does not expand in width when the stent is radially expanded.

29. The stent of claim 27 wherein the projecting element is integral with or attached to a single strut only at a single point on the projecting element.

30. The system of claim 27 wherein at least one strut and at least one projecting element comprises the biologically active material.

31. The system of claim 27 wherein the biologically active material is selected from paclitaxel, a derivative of paclitaxel or an analog of paclitaxel.

32. The stent of claim 27 wherein the projecting elements are integral with the struts.

1/13

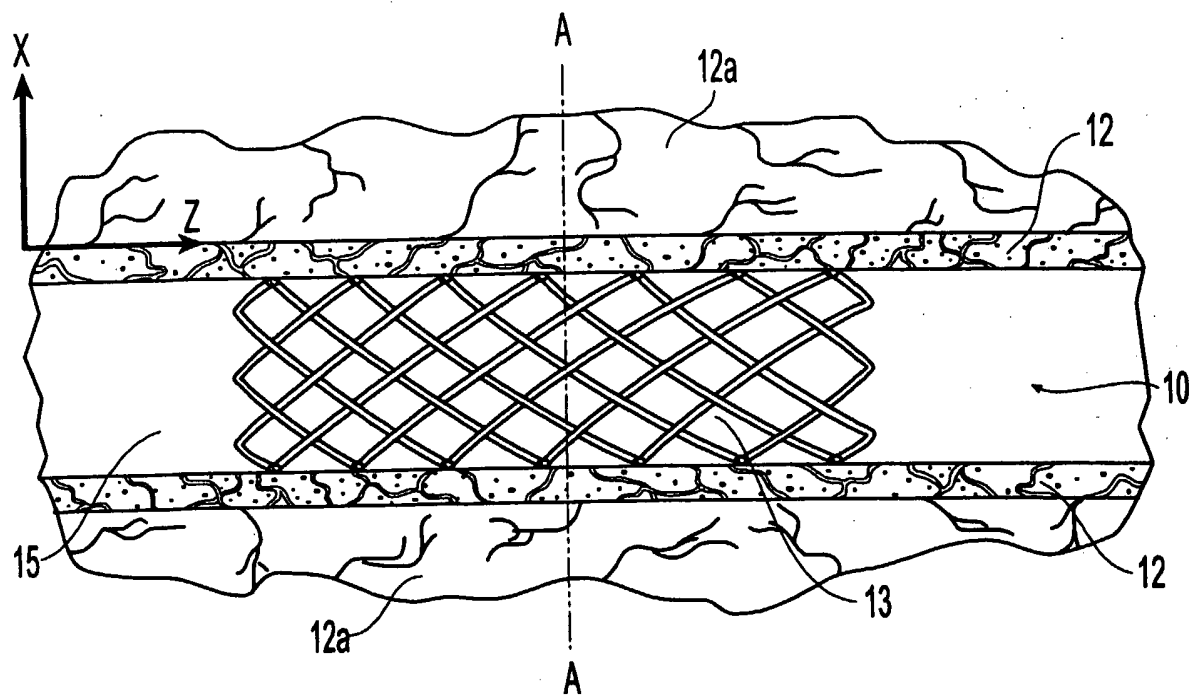

Fig. 1

2/13

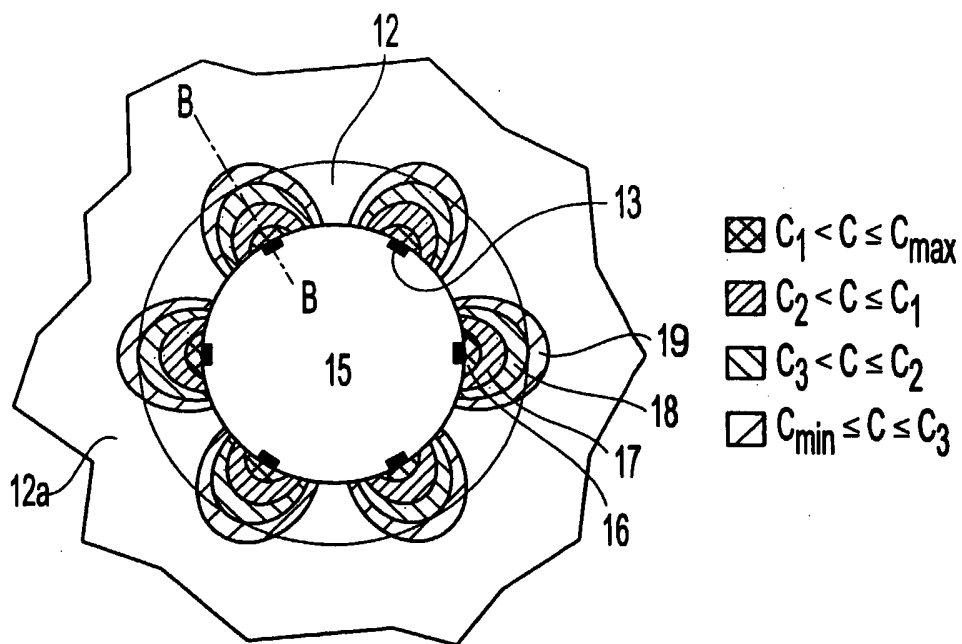

Fig. 2A

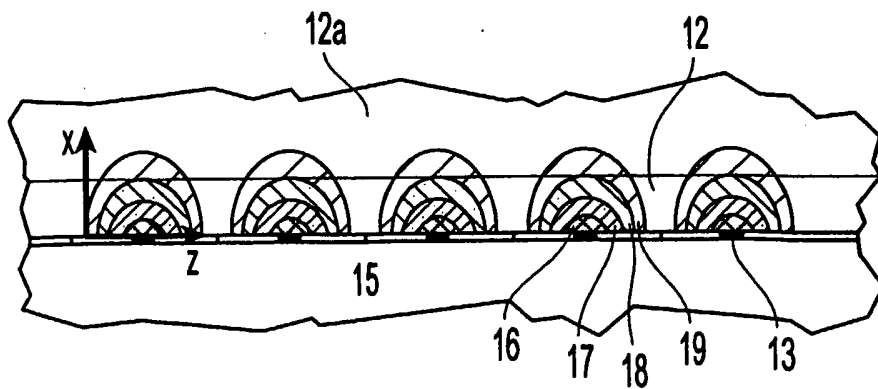

Fig. 2B

3/13

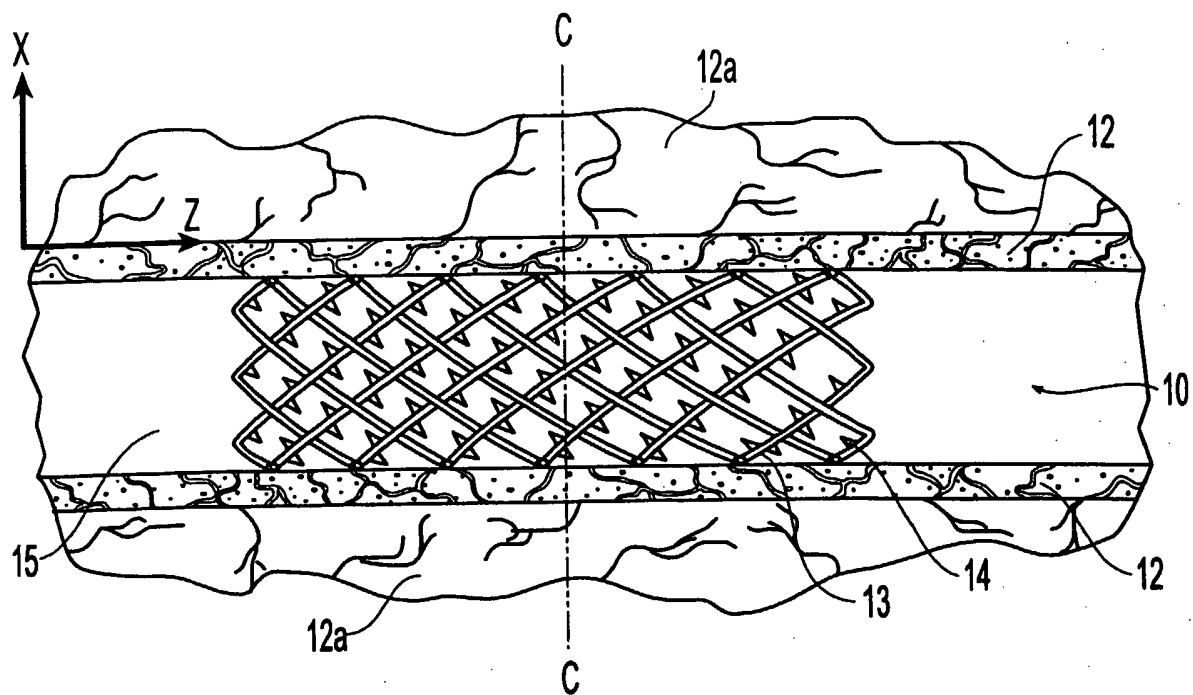

Fig. 3

4/13

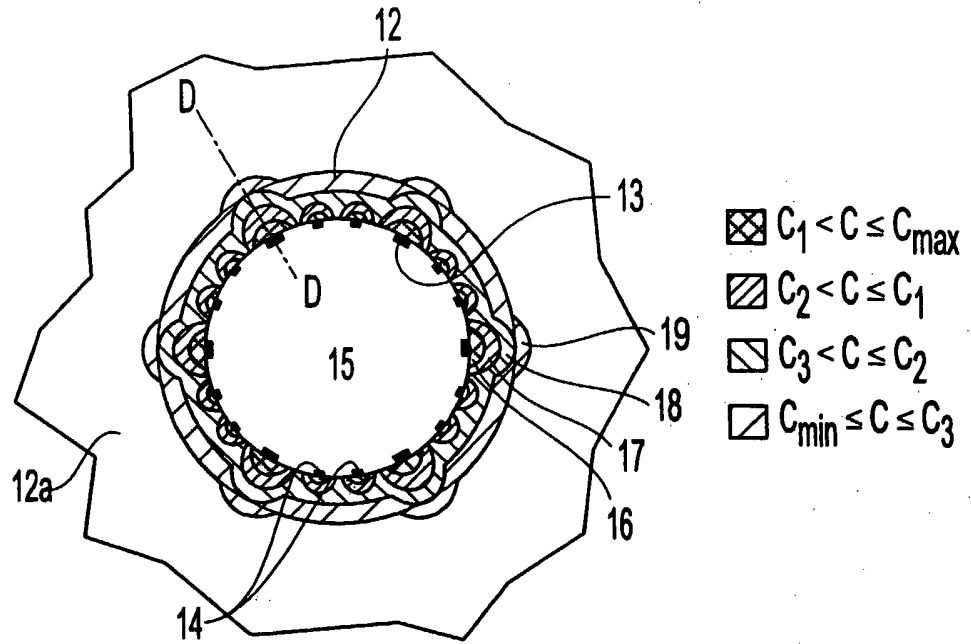

Fig. 4A

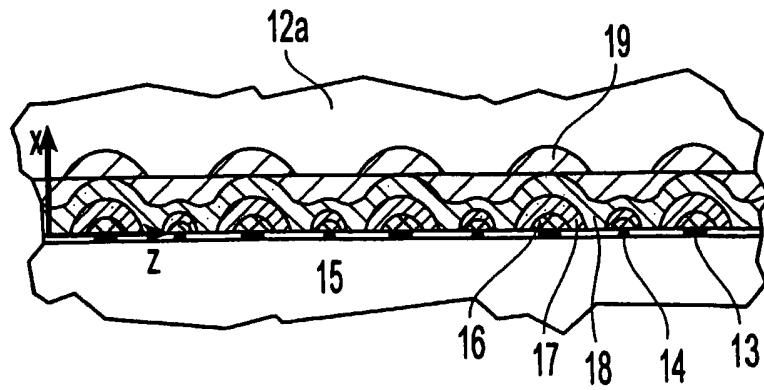

Fig. 4B

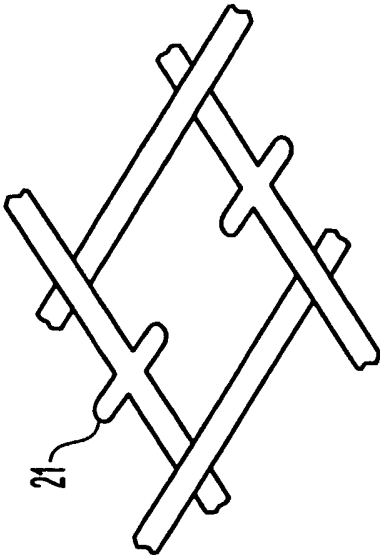

Fig. 5

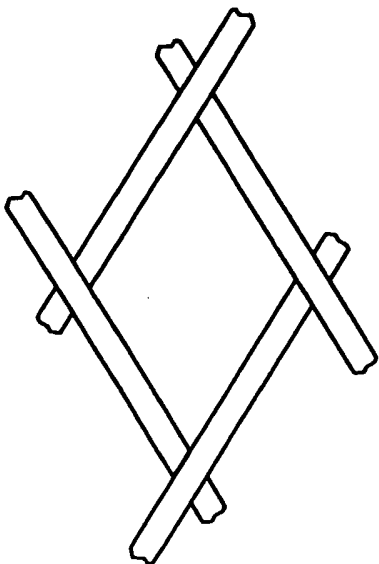

Fig. 6

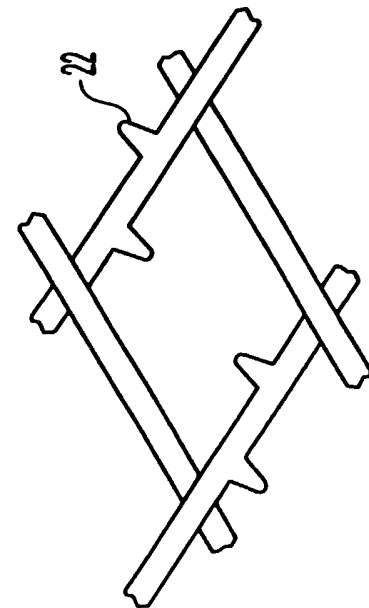

Fig. 7

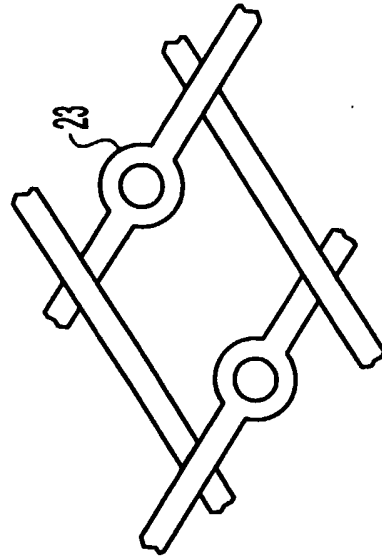

Fig. 8

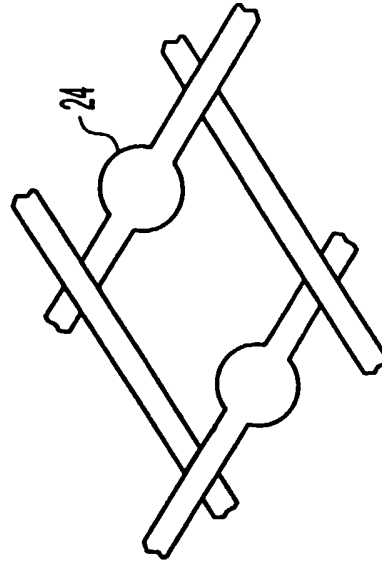

Fig. 9

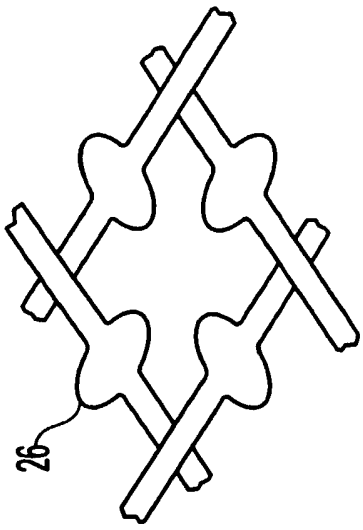

Fig. 11

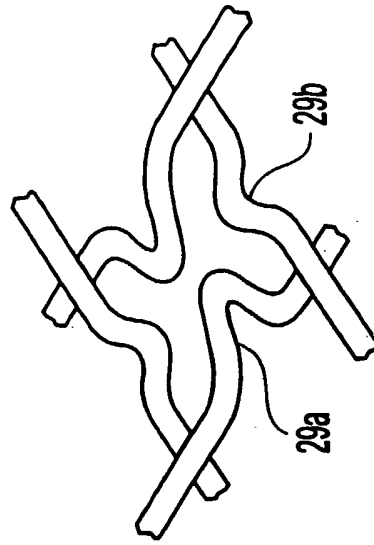

Fig. 14

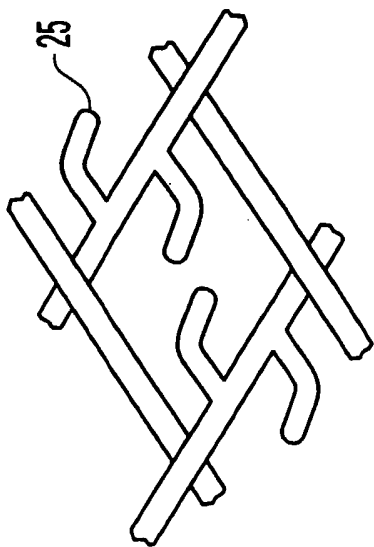

Fig. 10

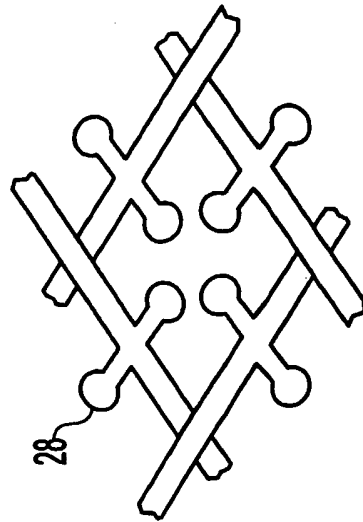

Fig. 13

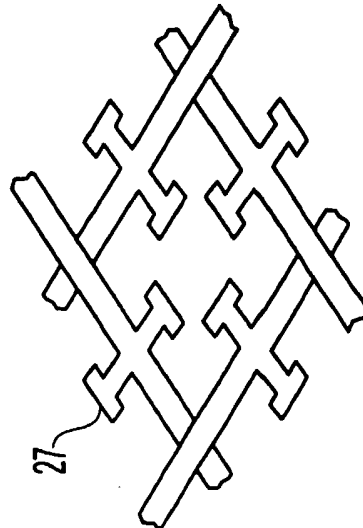

Fig. 12

7/13

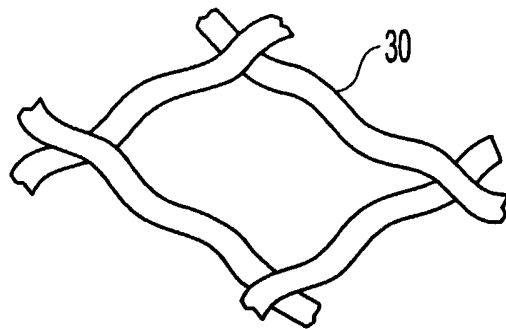

Fig. 15

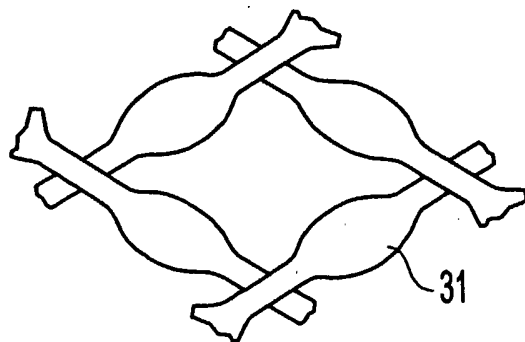

Fig. 16

8/13

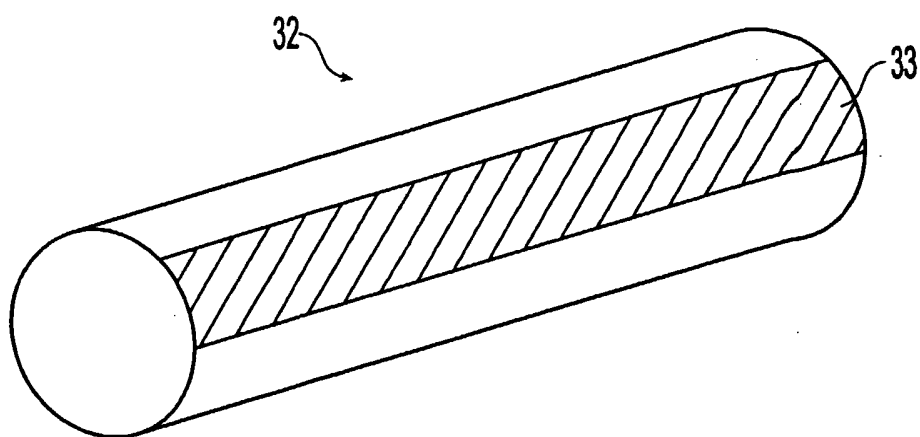

Fig. 17

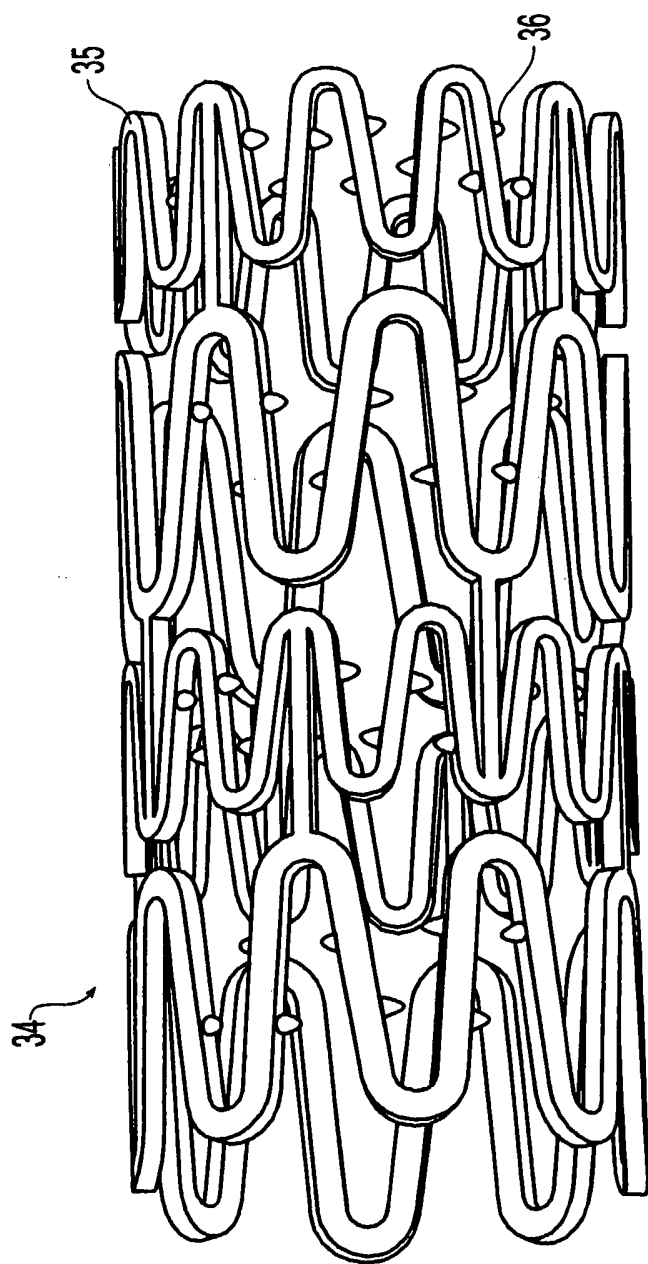

Fig. 18

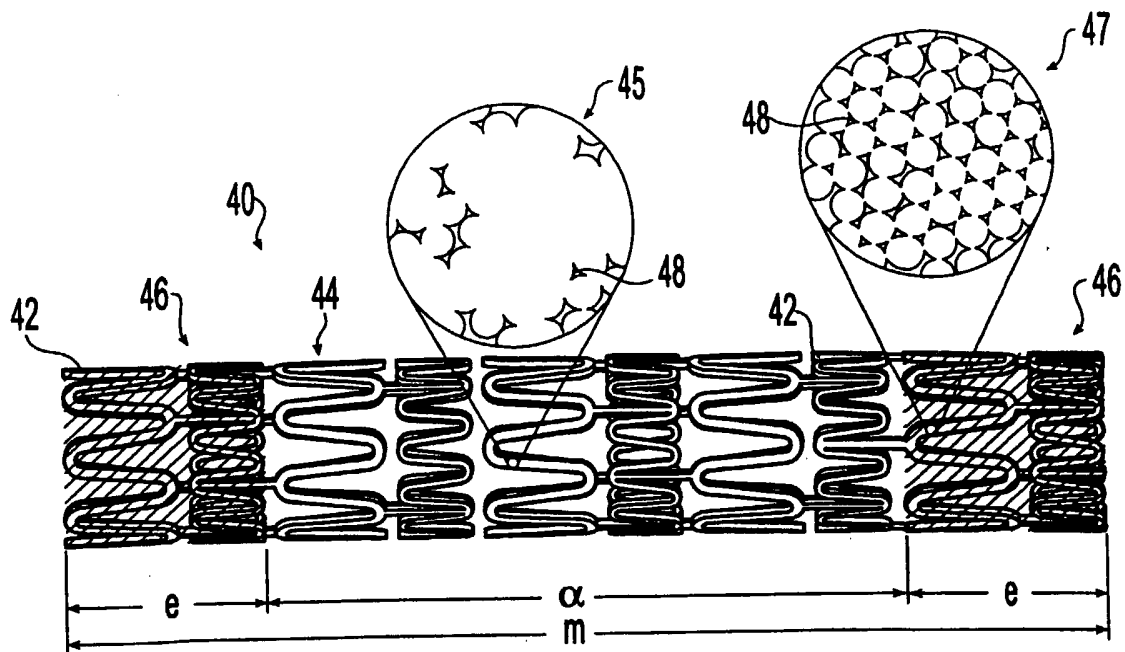

Fig. 19

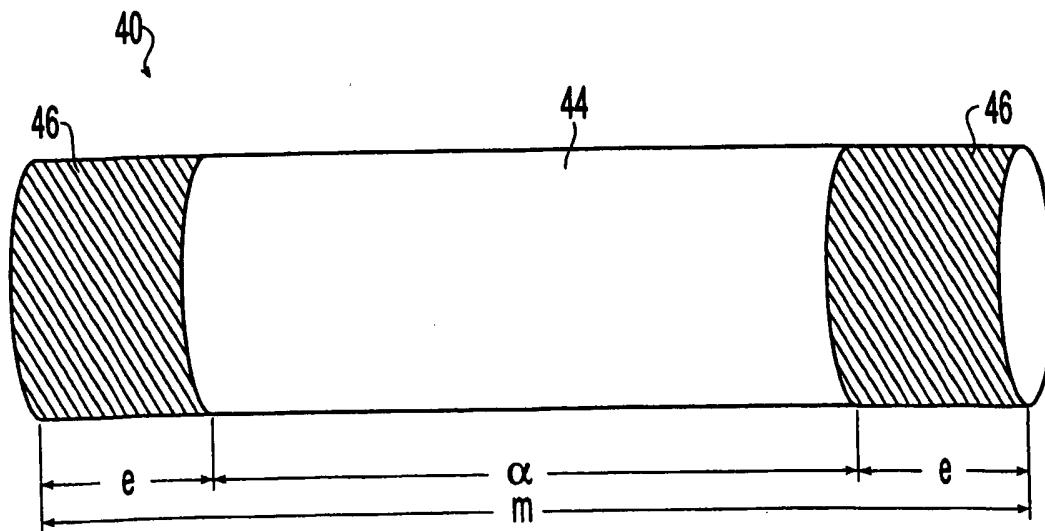

Fig. 20

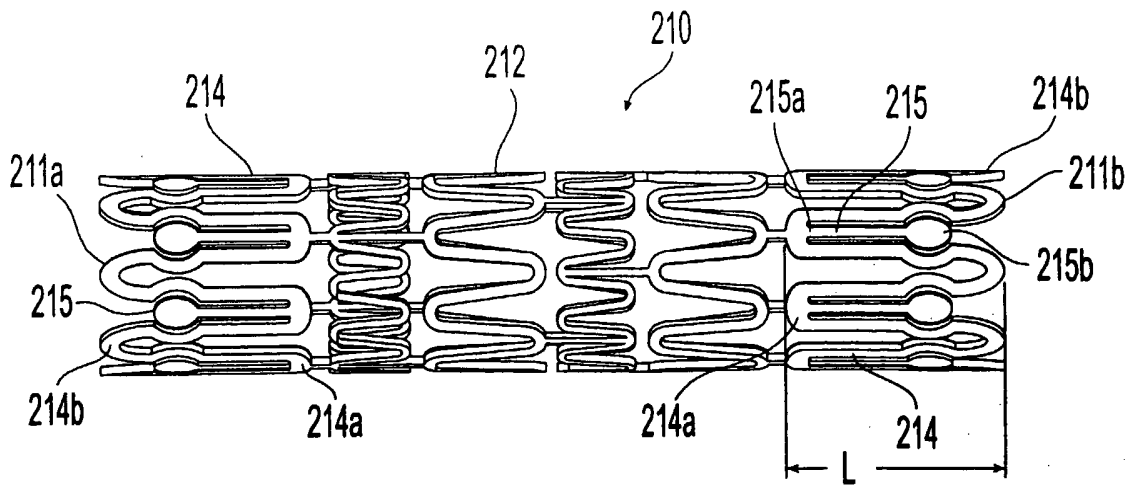

Fig. 21

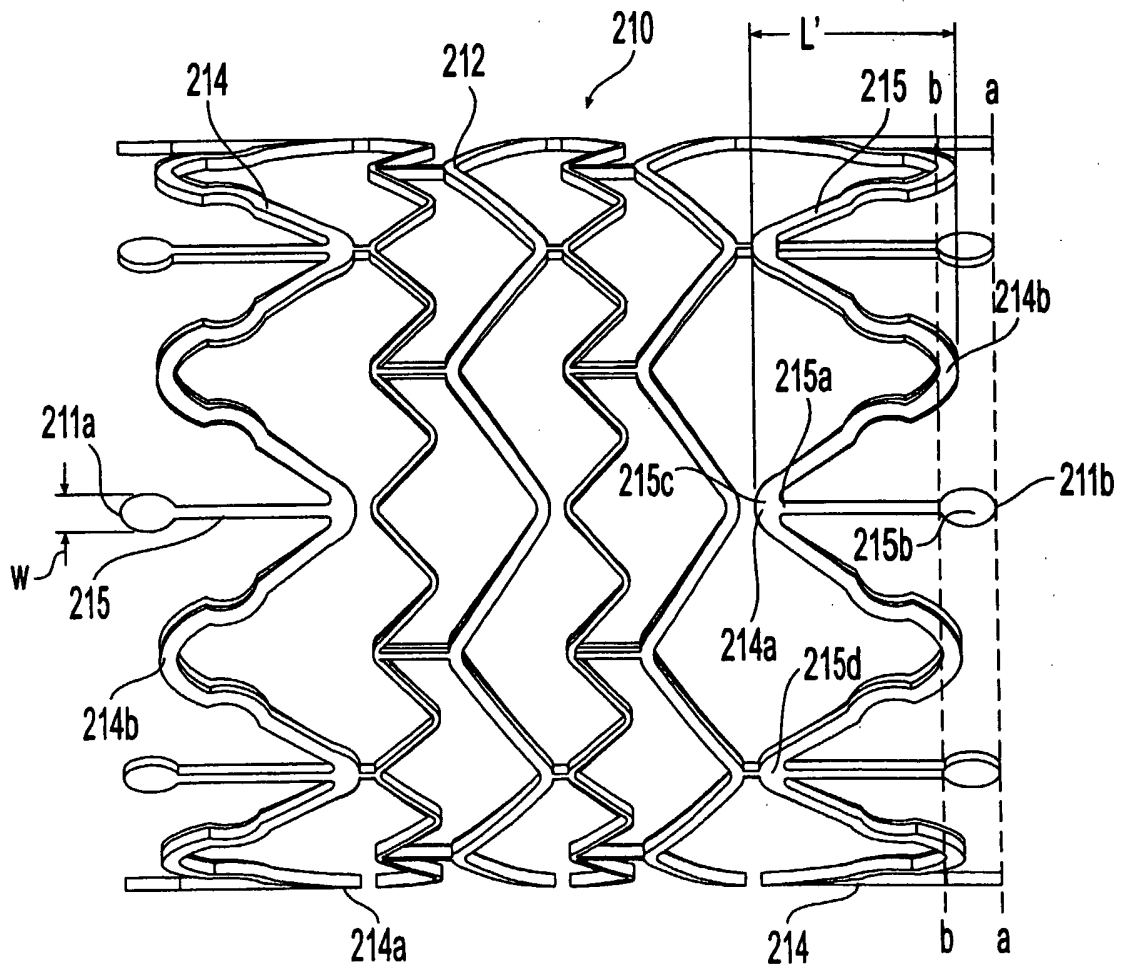

Fig. 22

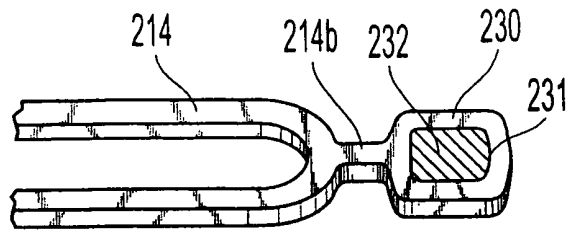

Fig. 23

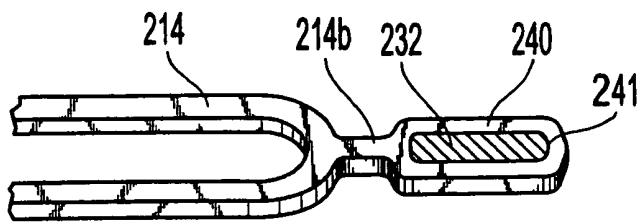

Fig. 24

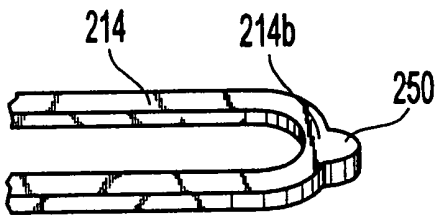

Fig. 25

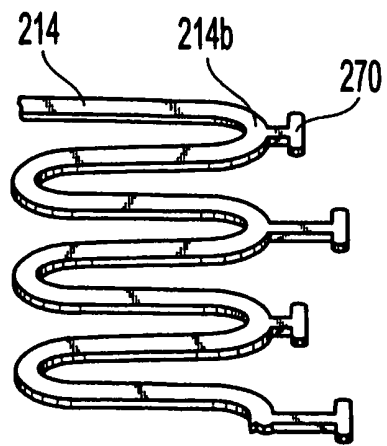

Fig. 27

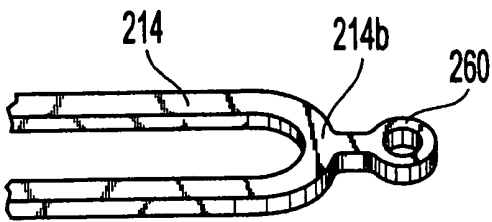

Fig. 26

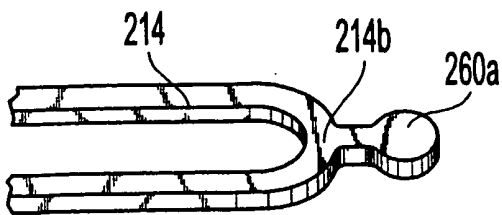

Fig. 26A

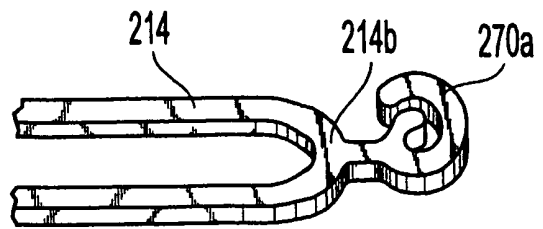

Fig. 27A

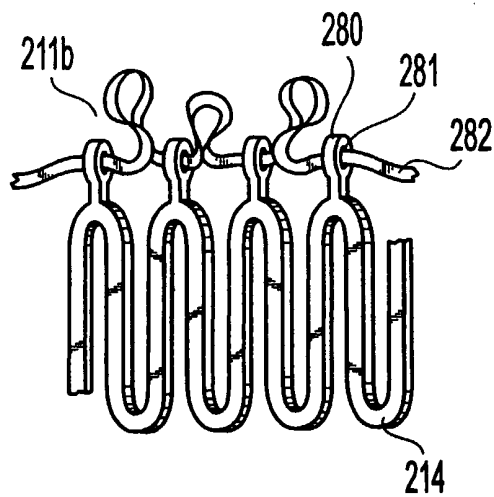

Fig. 28

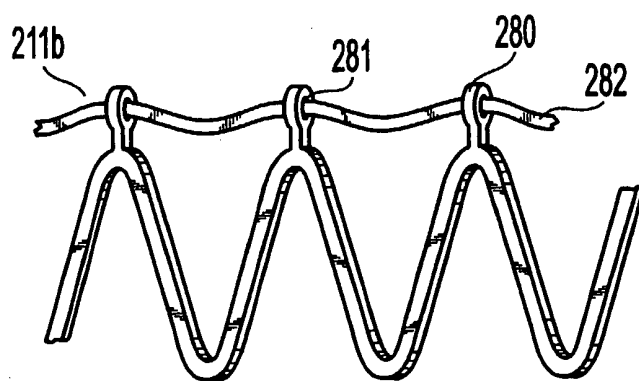

Fig. 29

INTERNATIONAL SEARCH REPORT

International application No.

PCT/US05/25293

A. CLASSIFICATION OF SUBJECT MATTER

IPC(7) : A61F 2/06
 US CL : 623/1.15, 1.46

According to International Patent Classification (IPC) or to both national classification and IPC

B. FIELDS SEARCHED

Minimum documentation searched (classification system followed by classification symbols)
 U.S. : 623/1.15-1.48

Documentation searched other than minimum documentation to the extent that such documents are included in the fields searched

Electronic data base consulted during the international search (name of data base and, where practicable, search terms used)
 Please See Continuation Sheet

C. DOCUMENTS CONSIDERED TO BE RELEVANT

Category *	Citation of document, with indication, where appropriate, of the relevant passages	Relevant to claim No.
Y	US 6,863,685 B2 (DAVILA et al) 08 March 2005(08.03.2005), see entire document.	1-11, 14-25, 27-30 and 32
Y	US 6,562,065 B1 (STANLEY et al.) 13 May 2003(13.05.2003), see entire document.	1-11, 14-25, 27-30 and 32
Y	US 6,379,382 B1 (YANG) 30 April 2002(30.04.2002), see entire document.	9
---		-----
A		12, 13

Further documents are listed in the continuation of Box C.

See patent family annex.

* Special categories of cited documents:	
"A" document defining the general state of the art which is not considered to be of particular relevance	"T" later document published after the international filing date or priority date and not in conflict with the application but cited to understand the principle or theory underlying the invention
"E" earlier application or patent published on or after the international filing date	"X" document of particular relevance; the claimed invention cannot be considered novel or cannot be considered to involve an inventive step when the document is taken alone
"L" document which may throw doubts on priority claim(s) or which is cited to establish the publication date of another citation or other special reason (as specified)	"Y" document of particular relevance; the claimed invention cannot be considered to involve an inventive step when the document is combined with one or more other such documents, such combination being obvious to a person skilled in the art
"O" document referring to an oral disclosure, use, exhibition or other means	"&" document member of the same patent family
"P" document published prior to the international filing date but later than the priority date claimed	

Date of the actual completion of the international search

19 September 2005 (19.09.2005)

Date of mailing of the international search report

09 NOV 2005

Name and mailing address of the ISA/US

Mail Stop PCT, Attn: ISA/US
 Commissioner for Patents
 P.O. Box 1450
 Alexandria, Virginia 22313-1450

Facsimile No. (703) 305-3230

Authorized officer

Rositha Lawrence
 Julie Burke

Telephone No. (571) 272-1600

INTERNATIONAL SEARCH REPORT

International application No.
PCT/US05/25293

Continuation of B. FIELDS SEARCHED Item 3:

EAST: US-PGPUB; USPAT; USOCR; EPO; JPO; DERWENT, IS&R, BRS, CCLS. URPN and (end or ends) and (extention or projection), stent same strut, project or projects) same (drug or drugd or agent or agents or therap. (strut or struts) and ends and (extention or projection or projects or tab or tabs) same active same material