



(12) **DEMANDE DE BREVET CANADIEN
CANADIAN PATENT APPLICATION**

(13) **A1**

(86) Date de dépôt PCT/PCT Filing Date: 2017/05/29
(87) Date publication PCT/PCT Publication Date: 2017/12/07
(85) Entrée phase nationale/National Entry: 2018/10/23
(86) N° demande PCT/PCT Application No.: EP 2017/025150
(87) N° publication PCT/PCT Publication No.: 2017/207116
(30) Priorité/Priority: 2016/05/30 (EP16172031.3)

(51) Cl.Int./Int.Cl. *G01N 21/57* (2006.01),
G01N 21/86 (2006.01), *G01N 21/89* (2006.01),
G01N 21/88 (2006.01)
(71) Demandeur/Applicant:
BOBST MEX SA, CH
(72) Inventeurs/Inventors:
RICHARD, MATTHIEU, FR;
PILLOUD, FRANCIS, CH
(74) Agent: SMART & BIGGAR

(54) Titre : SYSTEME D'INSPECTION DE SURFACE ET PROCEDE D'INSPECTION DE SURFACE
(54) Title: SURFACE INSPECTION SYSTEM AND SURFACE INSPECTION METHOD

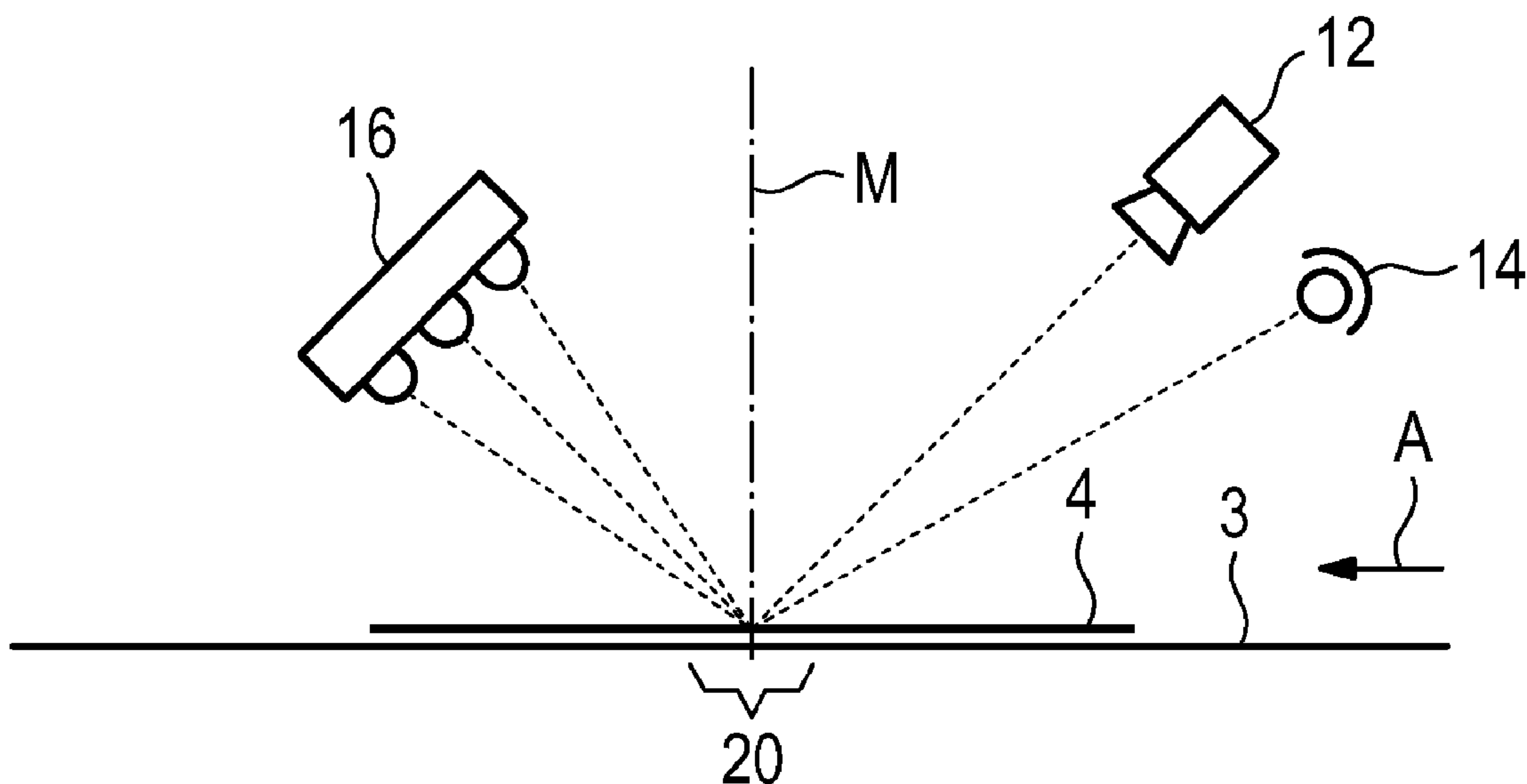

Fig. 3

(57) **Abrégé/Abstract:**

The invention relates to a surface inspection system (10) for inspecting the surface of sheet elements (4) present in an inspection area (20), comprising an image evaluation unit (18), a camera (12), a dark-field illuminator (14) and a bright-field illuminator (16), the image evaluation unit (18) is adapted for subtracting a line image captured under bright-field illumination conditions from a line image captured under dark-field illumination conditions. The invention further relates to a method of identifying highly reflective surface areas on a sheet element (4) being moved through a sheet element processing machine, wherein first a line image (I16) of the surface of the sheet element (4) in the viewing area (20) is being captured under bright-field illumination conditions and a line image (I14) of the same surface of the sheet element (4) in the viewing area (20) is being captured under dark-field illumination conditions, and wherein then the two line images (I14, I16) are being compared, in particular subtracted from each other, wherein the surface is identified as being reflective if the difference (Sn) between the two line images (I14, I16) is above a predefined threshold.

(12) INTERNATIONAL APPLICATION PUBLISHED UNDER THE PATENT COOPERATION TREATY (PCT)

(19) World Intellectual Property
Organization
International Bureau(10) International Publication Number
WO 2017/207116 A1(43) International Publication Date
07 December 2017 (07.12.2017)

(51) International Patent Classification:

G01N 21/57 (2006.01) *G01N 21/89* (2006.01)
G01N 21/86 (2006.01) *G01N 21/88* (2006.01)

(21) International Application Number:

PCT/EP2017/025150

(22) International Filing Date:

29 May 2017 (29.05.2017)

(25) Filing Language:

English

(26) Publication Language:

English

(30) Priority Data:

16172031.3 30 May 2016 (30.05.2016) EP

(71) Applicant: **BOBST MEX SA** [CH/CH]; Route de Faraz 3, 1031 MEX (CH).(72) Inventors: **RICHARD, Matthieu**; 2 rue des Perrières, 25160 Remoray (FR). **PILLOUD, Francis**; Rue du Port 18, 1815 Clarens (CH).(81) Designated States (*unless otherwise indicated, for every kind of national protection available*): AE, AG, AL, AM, AO, AT, AU, AZ, BA, BB, BG, BH, BN, BR, BW, BY, BZ, CA, CH, CL, CN, CO, CR, CU, CZ, DE, DJ, DK, DM, DO, DZ, EC, EE, EG, ES, FI, GB, GD, GE, GH, GM, GT, HN,

HR, HU, ID, IL, IN, IR, IS, JP, KE, KG, KH, KN, KP, KR, KW, KZ, LA, LC, LK, LR, LS, LU, LY, MA, MD, ME, MG, MK, MN, MW, MX, MY, MZ, NA, NG, NI, NO, NZ, OM, PA, PE, PG, PH, PL, PT, QA, RO, RS, RU, RW, SA, SC, SD, SE, SG, SK, SL, SM, ST, SV, SY, TH, TJ, TM, TN, TR, TT, TZ, UA, UG, US, UZ, VC, VN, ZA, ZM, ZW.

(84) Designated States (*unless otherwise indicated, for every kind of regional protection available*): ARIPO (BW, GH, GM, KE, LR, LS, MW, MZ, NA, RW, SD, SL, ST, SZ, TZ, UG, ZM, ZW), Eurasian (AM, AZ, BY, KG, KZ, RU, TJ, TM), European (AL, AT, BE, BG, CH, CY, CZ, DE, DK, EE, ES, FI, FR, GB, GR, HR, HU, IE, IS, IT, LT, LU, LV, MC, MK, MT, NL, NO, PL, PT, RO, RS, SE, SI, SK, SM, TR), OAPI (BF, BJ, CF, CG, CI, CM, GA, GN, GQ, GW, KM, ML, MR, NE, SN, TD, TG).

Declarations under Rule 4.17:

- as to applicant's entitlement to apply for and be granted a patent (Rule 4.17(ii))
- of inventorship (Rule 4.17(iv))

(54) Title: SURFACE INSPECTION SYSTEM AND SURFACE INSPECTION METHOD

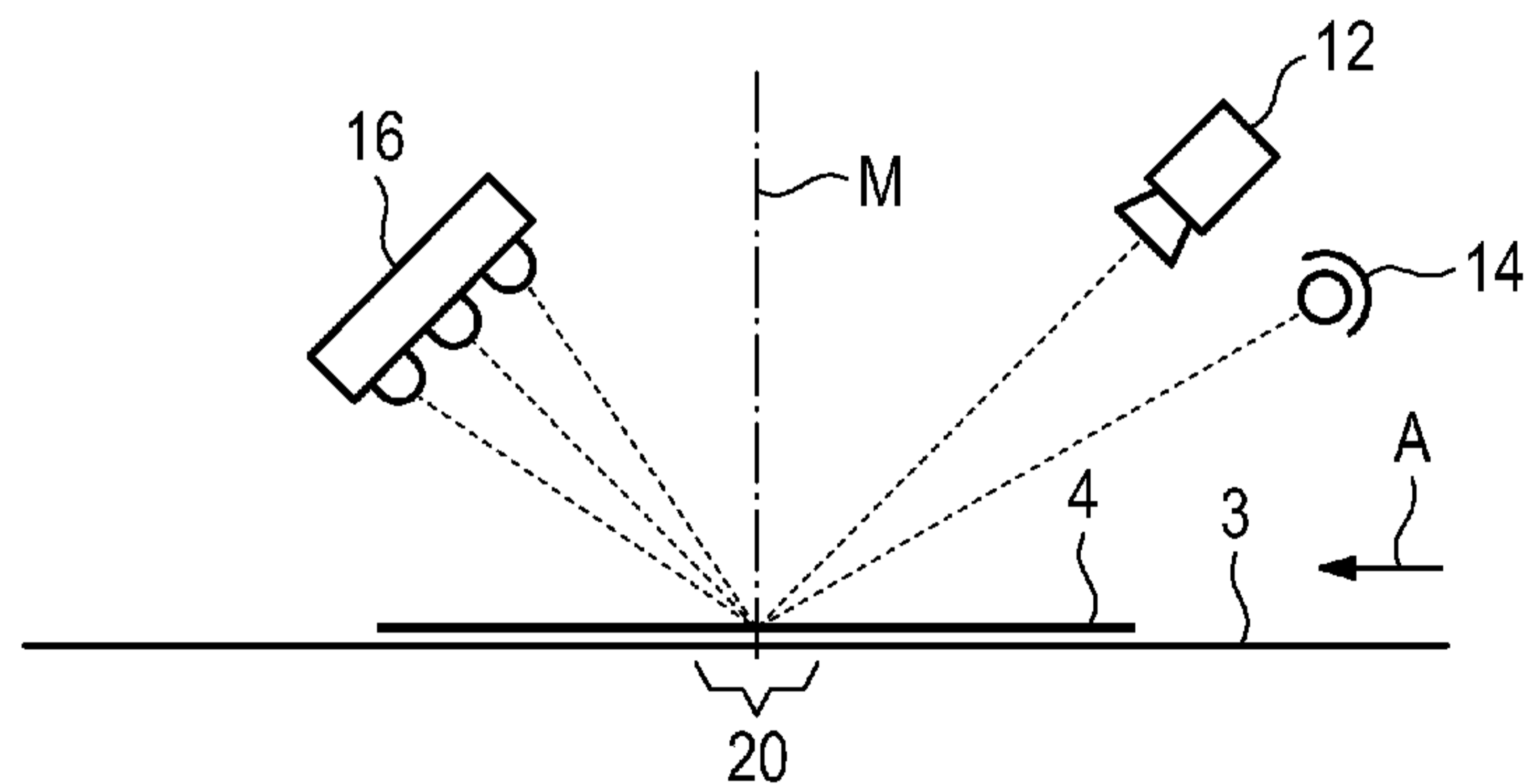

Fig. 3

(57) Abstract: The invention relates to a surface inspection system (10) for inspecting the surface of sheet elements (4) present in an inspection area (20), comprising an image evaluation unit (18), a camera (12), a dark-field illuminator (14) and a bright-field illuminator (16), the image evaluation unit (18) is adapted for subtracting a line image captured under bright-field illumination conditions from a line image captured under dark-field illumination conditions. The invention further relates to a method of identifying highly reflective surface areas on a sheet element (4) being moved through a sheet element processing machine, wherein first a line image (I_{16}) of the surface of the sheet element (4) in the viewing area (20) is being captured under bright-field illumination conditions and a line image (I_{14}) of the same surface of the sheet element (4) in the viewing area (20) is being captured under dark-field illumination conditions, and wherein then the two line images (I_{14} , I_{16}) are being compared, in particular subtracted from each other, wherein the surface is identified as being reflective if the difference (S_n) between the two line images (I_{14} , I_{16}) is above a predefined threshold.

[Continued on next page]

WO 2017/207116 A1 

Published:

- *with international search report (Art. 21(3))*
- *before the expiration of the time limit for amending the claims and to be republished in the event of receipt of amendments (Rule 48.2(h))*

Surface inspection system and surface inspection method

The invention relates to a surface inspection system for inspecting the surface of sheet elements present in an inspection area. The invention further relates to a method of identifying highly reflective surface areas on a sheet element being moved through a sheet element processing machine. The invention can in particular be implemented in a quality control station in a sheet element processing machine.

The term "sheet element processing machine" is here intended to comprise any machine which is being used for processing sheet elements such as paper, cardboard, plastic foil or similar materials, in particular printing machines, coating machines, laminating machines and converting machines (for example cutting, stamping, folding and/or gluing machines).

On the sheet element, highly reflective ("glossy") surfaces can be present as a consequence from foil, holograms, varnish or a similar structure being present. It is desirable for many reasons to be able to determine the position of glossy surfaces on a sheet element as many quality checks are based on checking the position of one element with respect to another element. However, it is not an easy task to detect the position of glossy surfaces on a sheet element being moved at speeds of up to 15m/s through a sheet element processing machine.

It is therefore an object of the invention to provide a system and a method which allow to reliably detect the position of glossy surfaces on a sheet element being moved through a sheet element processing machine.

In order to achieve this object, the invention provides a surface inspection system for inspecting the surface of sheet elements present in an inspection area, comprising an image evaluation unit, a camera, a dark-field illuminator and a bright-field illuminator, the image evaluation unit is adapted for comparing a line image captured under bright-field illumination conditions with a line image captured under dark-field illumination conditions. This object is also achieved with a method of identifying highly reflective surface areas on a sheet element being moved through a sheet element processing machine, in particular by using the system as defined above, wherein first a line image of the surface of the sheet element in the viewing

area is captured under bright-field illumination conditions and a line image of the same surface of the sheet element in the viewing area is captured under dark-field illumination conditions, and wherein then the two line images are compared, for example subtracted from each other, wherein the surface is identified as being
5 reflective if the difference between the two line images is above a predefined threshold.

The invention is based on the general concept of taking advantage of the difference in reflection which can be observed when illuminating diffusely reflecting surfaces like a Lambertian diffuser (e.g. white paper) on the one hand and glossy
10 surfaces (e.g. a foil, a hologram or varnish) on the other hand. When the illuminators illuminate a diffusely reflecting surface, the intensity of the line image captured by the camera is (almost) identical. When the illuminators illuminate a highly reflective surface, then the intensity, seen by the camera, of the light originating from the bright-field illuminator is much higher than the intensity of the
15 light originating from the dark-field illuminator. This difference can be detected relatively easily even at a sheet element being moved with high speeds.

The camera can be a 2D camera (area camera). In view of the amount of data to be processed, it however is preferred to use a line camera.

In view of the camera being preferably a line camera, the term "line image" is
20 in the following being used when referring to the images captured by the camera. If the camera however is an area camera, the line image captured by the camera does not consist of a single line only but of a plurality of lines.

According to a preferred embodiment, the dark-field illuminator comprises a single row of LEDs along which two oppositely arranged reflectors are provided.
25 Thus, the dark-field illuminator provides a light which is far from specular to prevent that any steep reflective area appears bright when illuminated by the dark-field illuminator.

The bright-field illuminator preferably comprises a plurality of rows of LEDs which are arranged in parallel. The different rows are arranged with different optical
30 planes so that there will always be some light which is being directly reflected, under close-to-specular reflection conditions, towards the camera even if the

surface of the sheet element in the viewing area is not perfectly plane. Thus, bright-field conditions are maintained even for steep areas on the sheet element.

The line image captured under bright-field illumination can be very easily compared with the line image captured under dark-field illumination if the intensity of the light originating from the dark-field illuminator is, at the camera, the same as the intensity of the light originating from the bright-field illuminator when a sheet element is being inspected which has a diffusely reflecting surface. If the comparison is made by subtracting the line images from each other, then the result is zero for surface portions which are not reflective.

In a preferred embodiment, the optical plane of the dark-field illuminator is arranged at an angle of approx 45° with respect to a plane which is perpendicular to the orientation of the viewing area, the optical plane of the bright-field illuminator is arranged at an angle of approx 30° with respect to a plane which is perpendicular to the orientation of the viewing area, and the viewing plane of the camera is arranged at an angle of approx. 20° with respect to a plane which is perpendicular to the orientation of the viewing area. This arrangement has proven to yield to good results.

With a view to achieving the desired precision when determining the position of glossy surfaces on the sheet element, the camera has a resolution, at the surface of the sheet element to be inspected, in the range of 0.05 to 0.6 mm and preferably of the order of 0.1 mm. A higher resolution is generally possible but results in more data having to be analyzed.

For determining the position of glossy surfaces on the sheet element, it is sufficient to compare the two line images as regards their intensity.

The images can be compared line by line and pixel by pixel so as to obtain precise information on the position of glossy surfaces both in the x direction and the y direction.

As an alternative, a reconstructed image is being created based on the line images captured under dark-field illumination, and a reconstructed image is being created based on the line images captured under bright-field illumination conditions, wherein reflective surfaces are being identified by comparing the

reconstructed images. This comparison can be made either for the entire reconstructed images or for selected parts only.

The sheet element is being moved with respect to the surface inspection system with a speed in the order 1 to 15 m/s. In order to allow a determination of the position in the x direction with the desired precision, it is preferred that the camera is adapted for capturing more than 10,000 line images/s and preferably more than 40,000 line images/s.

The invention will now be described with reference to a preferred embodiment which is shown in the enclosed drawings. In the drawings,

- 10 - Figure 1 schematically shows in a side view a surface inspection system according to the invention employed in a quality control station of a sheet element processing machine;
- Figure 2 schematically shows the surface inspection system of Figure 1 in a top view;
- 15 - Figure 3 schematically shows the surface inspection system of Figure 1 in greater detail;
- Figure 4 schematically shows different line images captured by the camera of the surface inspection system, and the result of a comparison of the line images;
- 20 - Figure 5 schematically shows the different line images captured by the camera; and
- Figure 6 schematically shows how reconstructed images are being generated based on the line images captured under different illumination conditions.

25 In Figure 1, a quality control station 2 is schematically shown, which is employed in a sheet element processing machine of which conveyor tables 3 can be seen. The sheet element processing machine can process sheet elements 4 which are being transported in the direction of arrow A. The sheet elements 4 can be sheets of paper, cardboard, plastic foil or a similar material, or they can be in
30 the form of a longer web. The sheet element processing machine can be a printing

machine, a stamping machine, a laminating machine, a folding machine, a gluing machine, etc.

The quality control station 2 is used for controlling the quality of the sheet elements 4. In particular, the quality control station 2 is used for determining the position of “glossy portions” on the surface of the sheet elements 4. “Glossy portions” are portions with a highly reflective surface. Examples for such glossy portions are holograms, foil and/or varnish present on the sheet element 4.

The quality control station comprises a surface inspection system 10. The surface inspection system 10 comprises a camera 12, a dark-field illuminator 14, a bright-field illuminator 16 and an image evaluation unit 18.

Camera 12 is adapted for capturing a line image of a viewing area (a line of interest) 20 which extends perpendicularly to the direction A over the entire width of the sheet element processing machine. It is arranged at an angle of approx. 20° with respect to a median plane M which is perpendicular to the surface of the sheet elements 4 within the viewing area.

Dark-field illuminator 14 is adapted for illuminating the viewing area 20. The optical plane of the dark-field illuminator 14 is arranged at an angle of approx. 45° with respect to median plane.

Dark-field illuminator 14 can generally be of any type. In a particular embodiment, it comprises a row of LEDs arranged adjacent each other, and two reflectors arranged opposite each other along the row of LEDs. This type of illuminator can be used for illuminating the surface of the sheet elements 4 in the viewing area 20 with an intensity which is constant despite variations in height.

Bright-field illuminator 16 is also adapted for illuminating the viewing area 20. The optical plane of the bright-field illuminator 16 is arranged at an angle of approx. 30° with respect to the median plane.

Bright-field illuminator 16 can generally be of any type. In a particular embodiment, it comprises several parallel rows of LEDs arranged adjacent each other, with each row being adapted for illuminating viewing area 20. This type of illuminator can be used in different applications for directing light in different directions to viewing area 20.

Further, a diffuser can be used for ensuring an even radiance when seen from viewing area 20 in order to have an even bright-field illuminator.

In view of the fact that illuminator 14 is being used as a dark-field illuminator, it is arranged on the same side of median plane M as camera 12. Illuminator 16 however is, since it is being used as a bright-field illuminator, arranged on the opposite side of median plane M. Depending on the particular circumstances, it is possible to use only one of the different rows of LEDs, namely the one which has its optical plane inclined with respect to median plane M by an angle close to 20°. In other words, it is the row of LEDs which camera 12 could see under specular reflection conditions on the surface of sheet element 4. As an alternative, several rows of LEDs of bright-field illuminator 16 are being used, with the optical plane of some of the rows being inclined at angles which are different from the angle at which camera 12 is arranged with respect to median plane M.

The important point here is that the power of the dark-field illuminator 14 and of the bright-field illuminator 16 is set or controlled such that the intensity of the light reflected to camera 12 from a diffusely reflecting surface of sheet element 4 is the same for both illuminators. In other words: the intensity of light originating from bright-field illuminator 16, reflected on a diffusely reflecting surface of sheet element 4 in viewing area 20 and then received by camera 12 is the same as the intensity of reflected light originating from dark-field illuminator 14, reflected on the same diffusely reflecting surface of sheet element 4 in viewing area 20 and then received by camera 12.

The diffusely reflecting surface can be paper or cardboard.

For inspecting the surface of sheet elements moved through quality inspection station 2, both illuminators 14, 16 are activated one after the other, and camera 12 captures a line image for each illumination situation. These line images are evaluated by image evaluation unit 18. The line images can in particular be subtracted from each other.

The method of determining the position of glossy surface portions on sheet elements 4 will now be described with reference to Figure 4 which helps understanding the basic principle underlying the subject image evaluation.

Figure 4 schematically shows in the upper half line images which are being captured by camera 12. In this example, each line image is shown to be twelve pixels wide. In practice, a line image covering the entire width of the viewing area 20 will consist of several thousands to several ten thousands of pixels as camera 12 usually has a resolution, in the viewing area at the level of the surface of the sheet elements, of the order of 0.05 mm to 0.3 mm and preferably of 0.1 mm.

The line images are here being captured in pairs, with the first line image I_{14} is being captured under dark-field illumination by means of dark-field illuminator 14, and line image I_{16} is being captured under bright-field illumination by means of bright-field illuminator 16. It obviously could be the other way around as well.

The maximum rate at which line images are being captures depends from the rate with which the illuminators 14, 16 can be switched on and off. Rates of up to 80 kHz are possible. Accordingly, camera 12 captures 80,000 line images per second.

The first pair of line images I_{14} , I_{16} is being captured from a surface in viewing area 20 which is diffusely reflecting. As the power of both illuminators was adjusted to result in the same intensity at camera 12, both line images are identical. This is here indicated by the pixels of the line image being empty which signifies a low intensity of captured light.

In the lower half of Figure 4, the result of an image evaluation performed by image evaluation unit 18 is shown. Here, the line images are subtracted from each other. Since the line images are identical, the result of the subtraction is zero for each pixel. This is here indicated by empty pixels in subtracted image S_1 .

The second pair of line images I_{14} , I_{16} is being captured from a surface in viewing area 20 which is diffusely reflecting for the majority of the width but which has a highly reflective portion, e.g. a stamped metallic foil which here is four pixels wide. The result is that camera 12 captures, when being illuminated by dark-field illuminator 14, even less intensity than before as the light is being reflected away from camera. The pixels of line image I_{14} are accordingly empty. When however being illuminated by bright-field illuminator 16, camera 12 captures a high intensity as at least some of the light is directly reflected towards the camera. Accordingly,

the four pixels where the stamped metallic foil reflects the light are shown black in order to signify a high intensity.

When subtracting the two line images from each other, the result is again zero for those pixels where were illuminated under diffuse reflection. For the pixels in
5 the area of the hologram however, the subtraction results in a high value (either positive or negative, depending from the order in which the two line images are being subtracted from each other). This high value is indicated by black pixels in subtracted image S_2 .

For the third pair of line images I_{14} , I_{16} , the situation is the same as before; it is
10 here assumed that the stamped metallic foil has not yet completely passed through the viewing area.

The fourth pair of line images I_{14} , I_{16} corresponds to a situation in which the hologram has been completely moved through the viewing area 20 so that sheet element 4 has a diffusely reflecting surface in viewing area 20. Accordingly, the
15 intensity of both captured line images is identical, and the result of the subtraction is zero for all pixels.

It is thus possible to determine where (both in the x direction and the y direction) glossy surface portions are present on a sheet element being moved through viewing area 20.

20 It can be understood that the term "same intensity under diffuse reflection" is not to be understood in a mathematical sense. Due to tolerances, the intensity will vary, and the intensity will also vary with the particular diffusely reflecting surface which is being illuminated. "The same intensity" thus means that the intensity of the light originating from either illuminator 14, 16 and reflected on a diffusely
25 reflecting surface is below a certain threshold which is chosen such that the intensity of the light originating from the bright-field illuminator 16 and reflected from a glossy surface being above this threshold. The threshold can be chosen depending from the surfaces being inspected. As an example, a difference in intensity $< 1\%$ can be chosen for varnish + foil while a difference $< 10\%$ can be
30 chosen for foil only.

Different thresholds can be implemented by adjusting the power of the LEDs or by adjusting a coefficient applied to the captured line images.

It is also possible to analyze the captured line images as regards their grayscale intensity and to have the image evaluation unit analyze an image composed of subtracted images as regards sudden changes of the grayscale intensity.

Based on Figure 4, it was described that the line images obtained under bright-field illumination and the line images obtained under dark-field illumination are compared line by line. In practice, from the interlaced line images captured under the different illumination conditions, a reconstructed BFI image (reconstructed image consisting of the line images captured under bright-field illumination) and a reconstructed DFI image (reconstructed image consisting of the line images captured under dark-field illumination) will be created, and these images will be analyzed by the image evaluation unit.

Figure 5 schematically shows the interlaced line images I_{14} (shown in normal lines) and I_{16} (shown in dotted lines) captured by the camera. Here, only ten of the line images of each illumination condition are shown. In practice, several thousands of line images I_{14} , I_{16} are being captured for each sheet element 4. Assuming that 4,000 line images I_{14} and 4,000 line images I_{16} are being captures for one sheet element 4 and that camera 12 is able to capture 80,000 line images per second, then ten sheet elements 4 per second can be processed.

Figure 6 schematically shows how a reconstructed DFI image 40 is reconstructed from the line images I_{14} and how a reconstructed BFI image 50 is reconstructed from line images I_{16} .

Should camera 12 capture line images under more than the two illumination conditions which are described here (BFI and DFI) and shown in Figure 5, then the data captured by camera 12 would consist of three or more types of interlaced line images, and three or more reconstructed images would be reconstructed (one for each illumination condition).

Image evaluation unit 18 processes the reconstructed images 40, 50 (either entirely or in those portions which are of interest) in order to detect an item of interest. Here, the reconstructed images 40, 50 are compared in order to identify reflective surface portions.

It can occur that surface portions of the sheet element 4 which are not perpendicular to median plane M result in light being reflected towards camera with

such an intensity that the threshold is surpassed. This results in a false reading (“artifact”) which can be identified by the image evaluation unit 18 because of its dimensions in the x direction; artifacts have length which is less than the usual length of surface portions with a highly reflective surface.

- 5 The surface inspection system 10 can be calibrated. This can be done either by placing a wide target in viewing area 20 or by moving a smaller target along the entire width of viewing area 20.

10 In addition, each LED or each group of LEDs is energized at an adjusted level along each illuminator to provide the same signal on the target along the width of viewing area 20.

The calibration is either used to adjust the operating power of the LEDs or to appropriately set the coefficient applied to the captured line images.

Claims

1. A surface inspection system (10) for inspecting the surface of sheet elements (4) present in an inspection area (20), comprising an image evaluation unit (18), a camera (12), a dark-field illuminator (14) and a bright-field illuminator (16), the image evaluation unit (18) is adapted for subtracting a line image captured under bright-field illumination conditions from a line image captured under dark-field illumination conditions.
5
2. The surface inspection system of claim 1 wherein the camera (12) is a line camera.
- 10 3. The surface inspection system of claim 1 or claim 2 wherein the dark-field illuminator (14) comprises a single row of LEDs along which two oppositely arranged reflectors are provided.
4. The surface inspection system of any of the preceding claims wherein the bright-field illuminator (16) comprises a plurality of rows of LEDs which are
15 arranged in parallel.
5. The surface inspection system of any of the preceding claims wherein the intensity of the light originating from the dark-field illuminator (14) being, at the camera (12), the same as the intensity of the light originating from the bright-field illuminator (16) when a sheet element (4) is being inspected which has a diffusely
20 reflecting surface.
6. The surface inspection system as defined in any of the preceding claims wherein the optical plane of the dark-field illuminator (14) is arranged at an angle of approx 45° with respect to a median plane (M) which is perpendicular to the orientation of the viewing area (20).
- 25 7. The surface inspection system as defined in any of the preceding claims wherein the optical plane of the bright-field illuminator (16) is arranged at an angle of approx 30° with respect to a median plane (M) which is perpendicular to the orientation of the viewing area (20).
8. The surface inspection system as defined in any of the preceding claims
30 wherein the viewing plane of the camera (12) is arranged at an angle of approx.

20° with respect to a median plane (M) which is perpendicular to the orientation of the viewing area (20).

9. The surface inspection system of any of the preceding claims wherein the camera (12) has a resolution, at the surface of the sheet element (4) to be inspected, in the range of 0.1 to 0.6 mm and preferably in the order of 0.3 mm.

10. A method of identifying reflective surface areas on a sheet element (4) being moved through a sheet element processing machine, in particular by using the system as defined in any of the preceding claims, wherein first a line image (I_{16}) of the surface of the sheet element (4) in the viewing area (20) is being captured under bright-field illumination conditions and a line image (I_{14}) of the same surface of the sheet element (4) in the viewing area (20) is being captured under dark-field illumination conditions, and wherein then the two line images (I_{14} , I_{16}) are being compared, for example subtracted from each other, wherein the surface is identified as being reflective if the difference (S_n) between the two line images (I_{14} , I_{16}) is above a predefined threshold.

11. The method of claim 10 wherein the two line images (I_{14} , I_{16}) are compared as regards their intensity.

12. The method of claim 10 or claim 11 wherein the line images (I_{14} , I_{16}) are compared pixel by pixel.

13. The method of any of claim 10 to 12 wherein a reconstructed image is being created based on the line images captured under dark-field illumination and wherein a reconstructed image is being created based on the line images captured under bright-field illumination conditions, and wherein reflective surfaces are being identified by comparing the reconstructed images.

14. The method of any of claims 10 to 13 wherein the camera (12) is adapted for capturing more than 10,000 line images/s and preferably more than 20,000 line images/s.

15. The method of any of claims 10 to 14 wherein the sheet element (4) is being moved with respect to the surface inspection system (10) with a speed in the order 5 to 15 m/s.

16. The method of any of claims 10 to 15 wherein the inspected sheet elements (4) at least partially have a reflective surface.

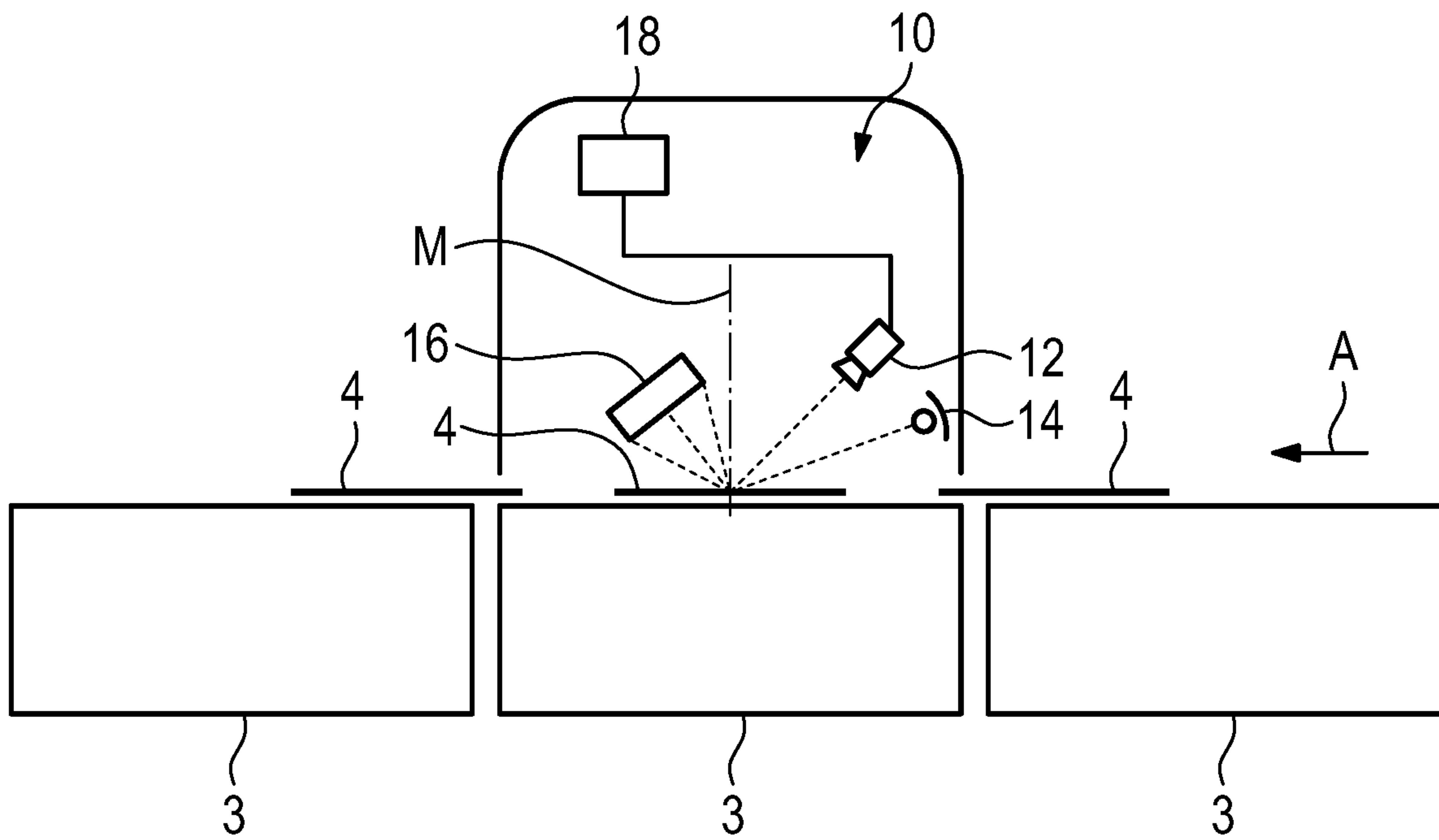

Fig. 1

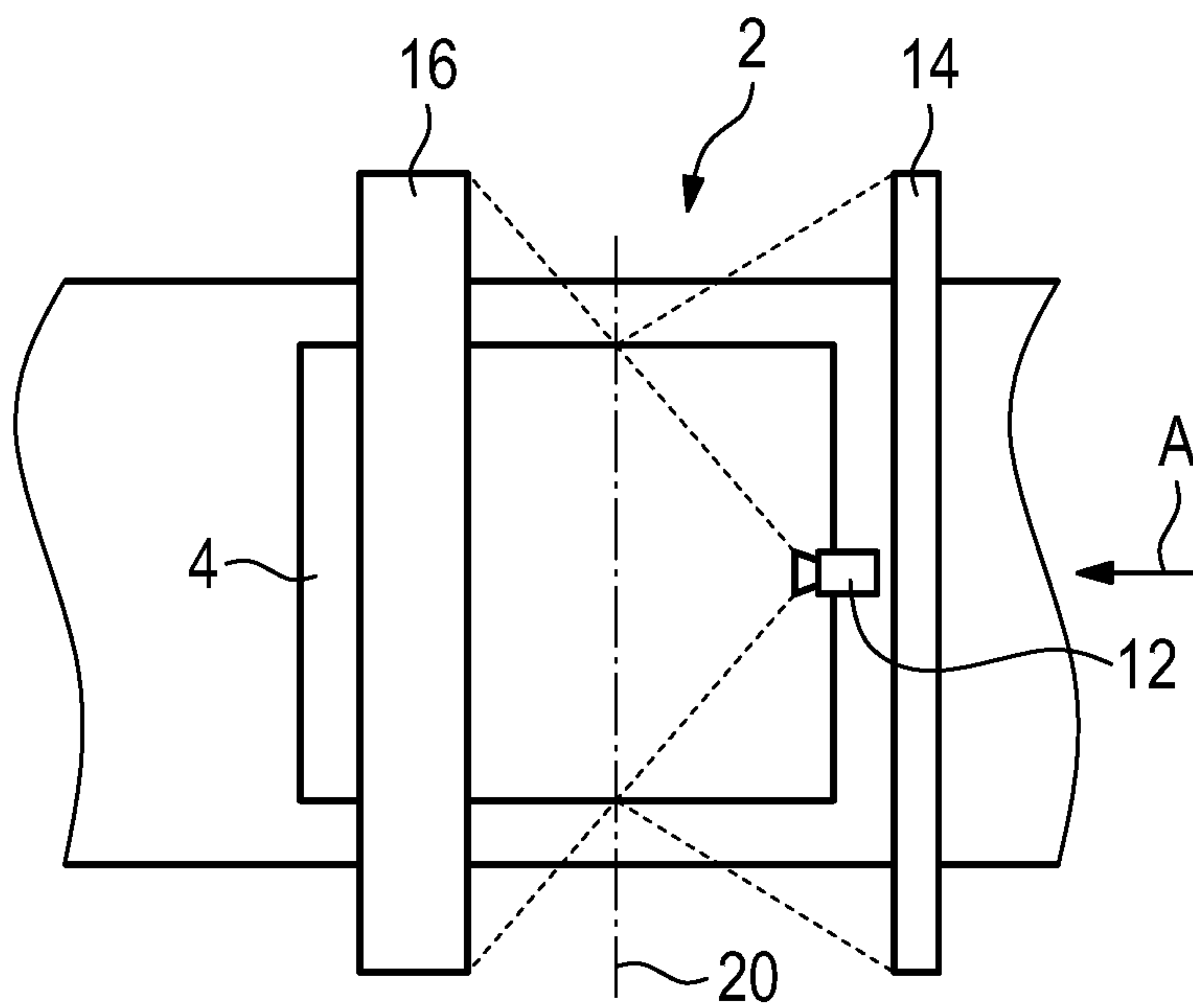

Fig. 2

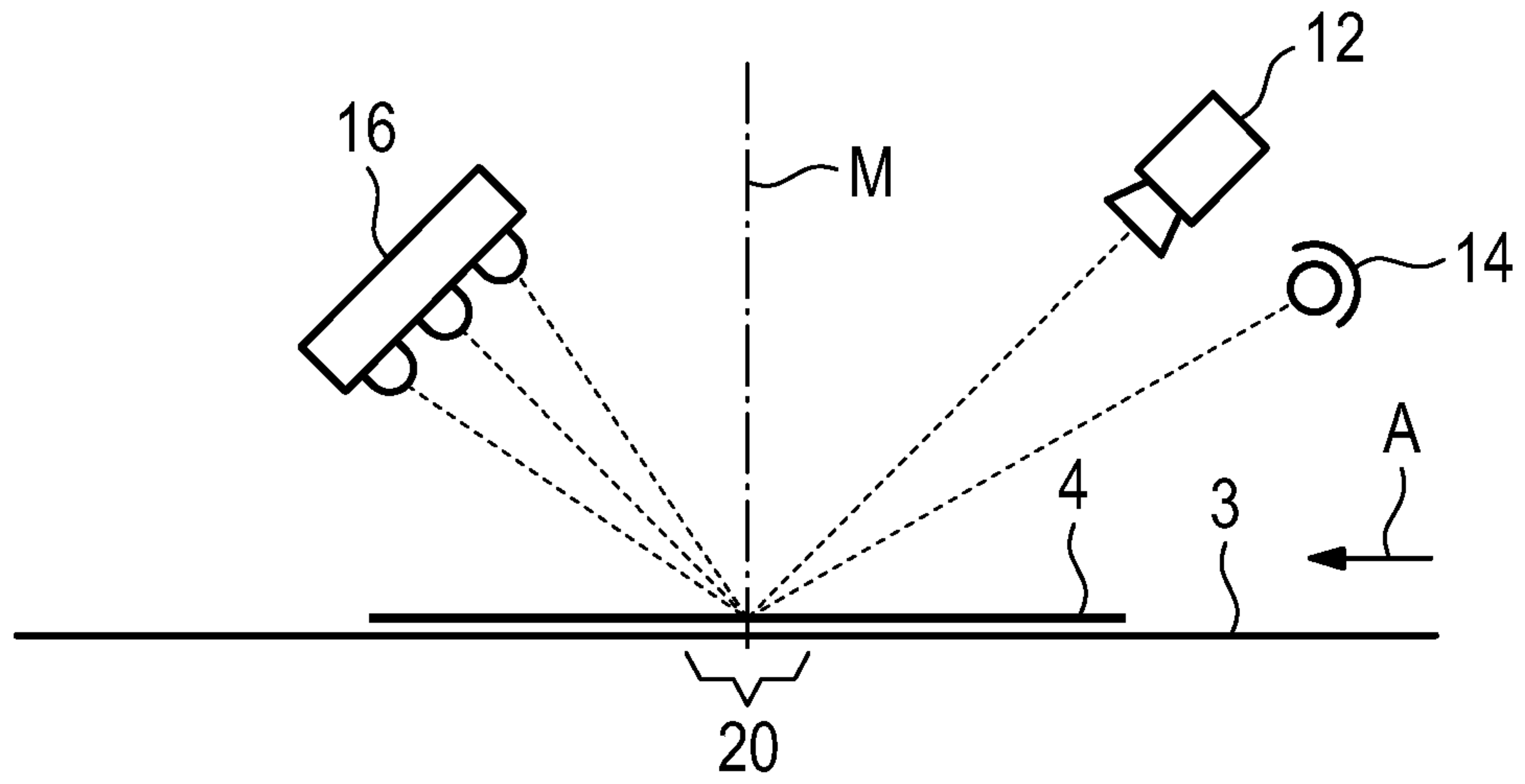

Fig. 3

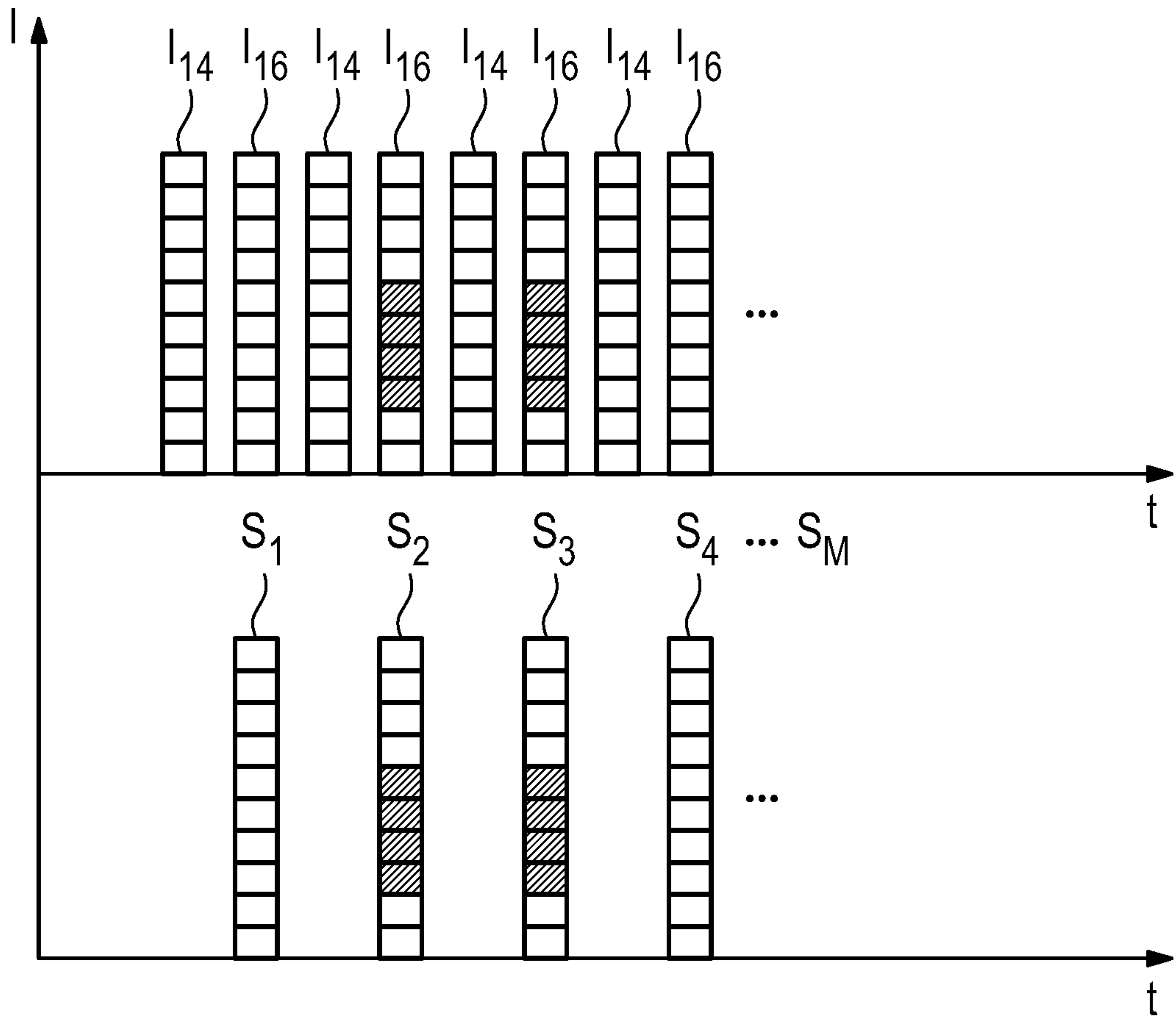

Fig. 4

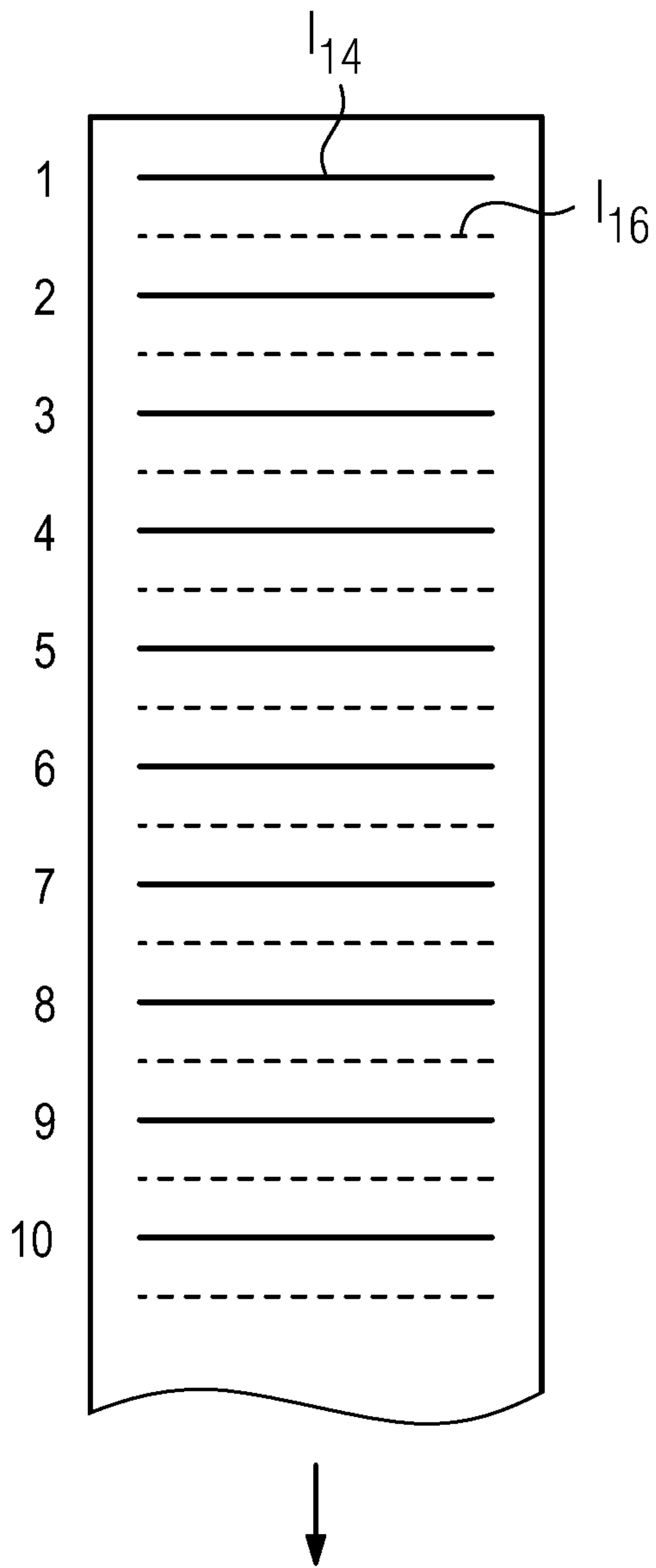

Fig. 5

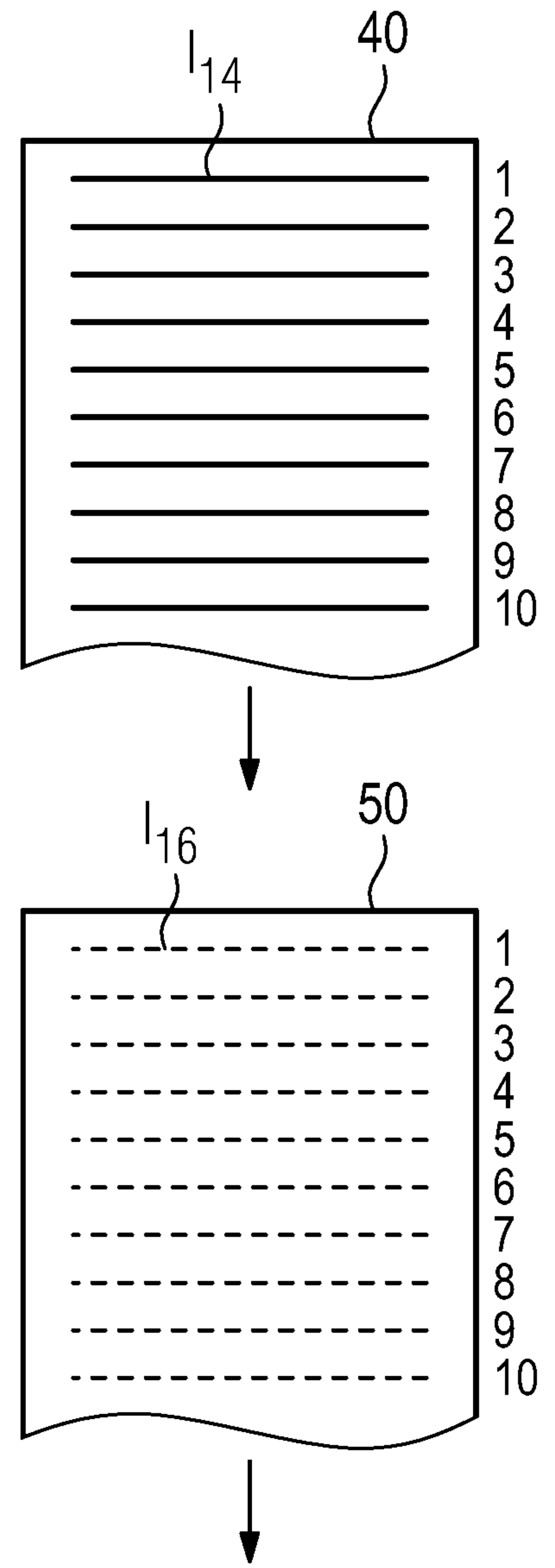

Fig. 6

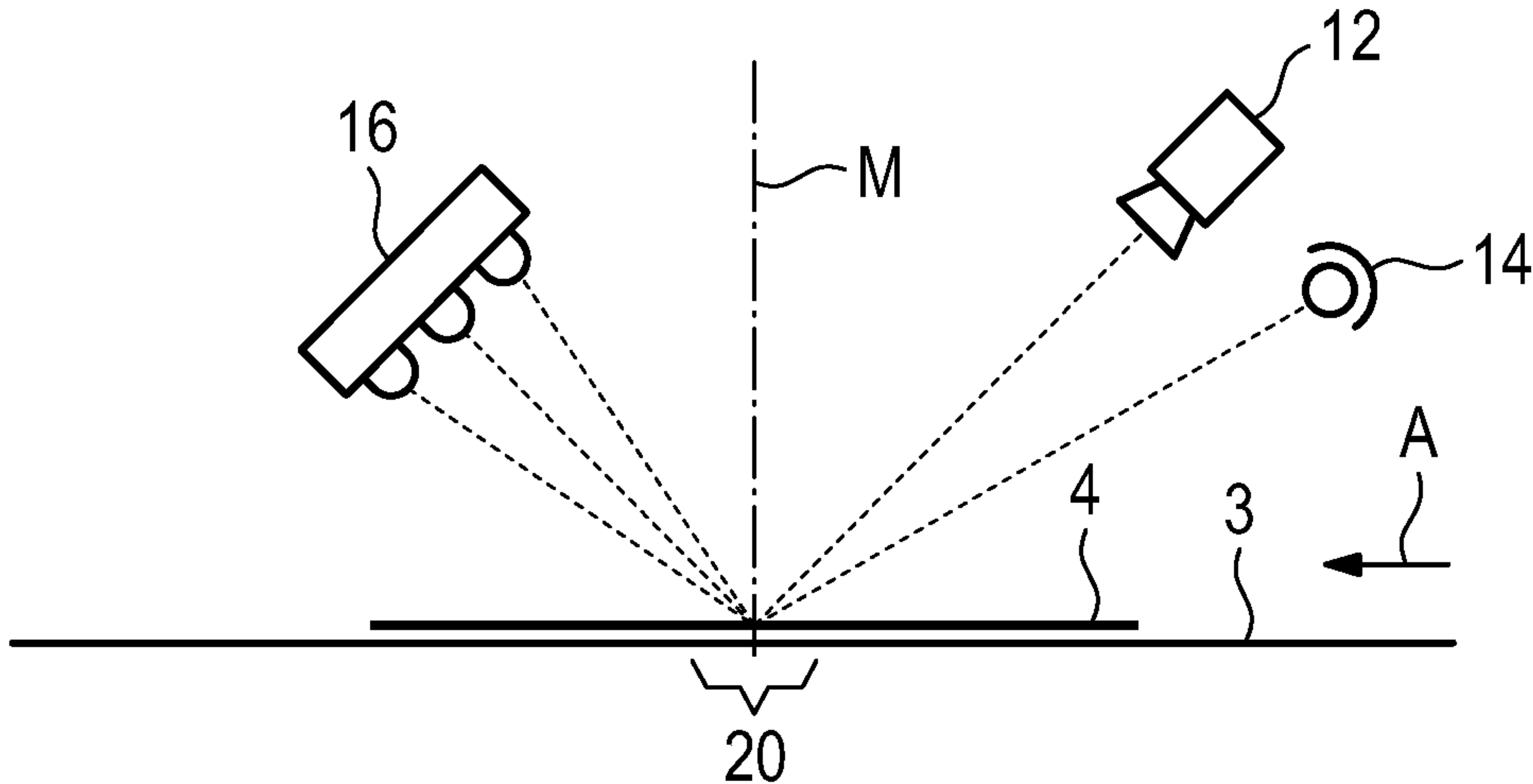

Fig. 3