

J. R. NEWMAN.  
SPRING BED-BOTTOM.

No. 180,909.

Patented Aug. 8, 1876.

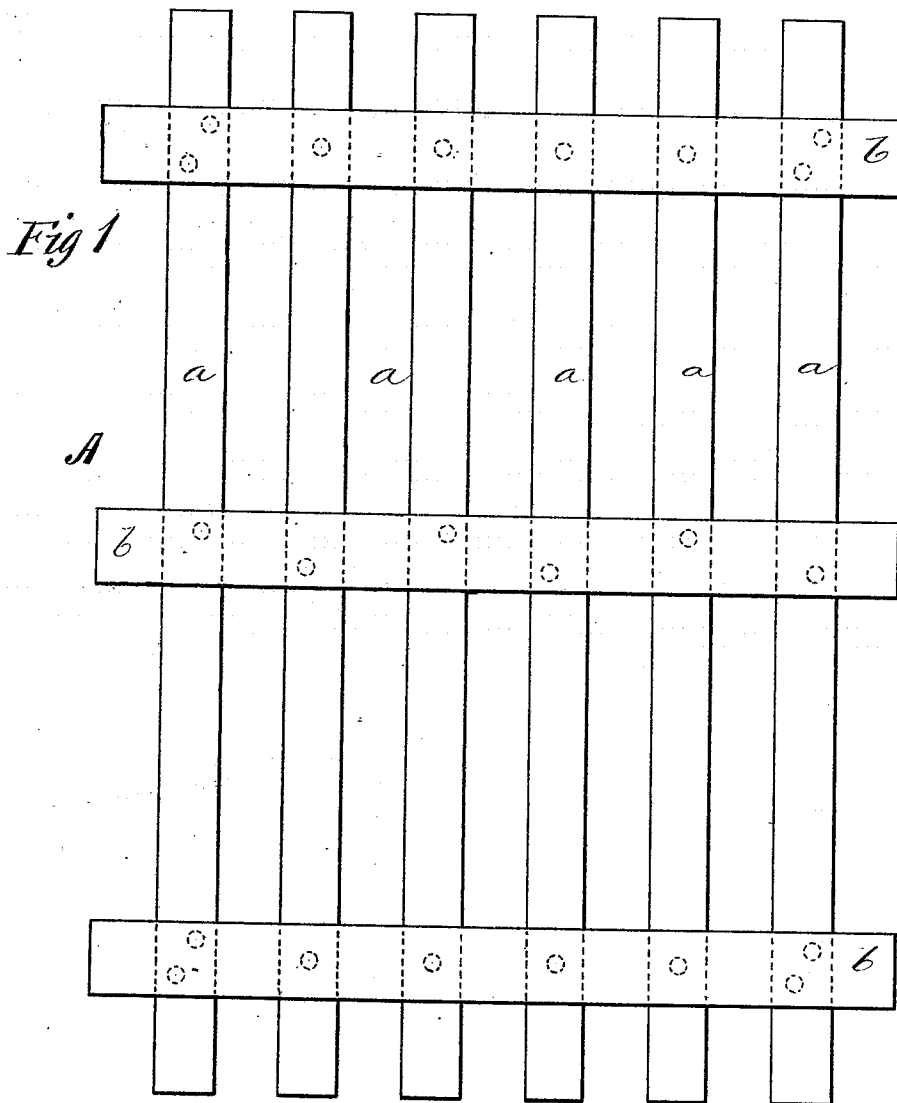

WITNESSES  
*Villette Anderson.*  
*F. J. Clasi*

INVENTOR  
*J. R. Newman.*  
*E. W. Anderson.*  
ATTORNEY.

J. R. NEWMAN.  
SPRING BED-BOTTOM.

No. 180,909.

Patented Aug. 8, 1876.

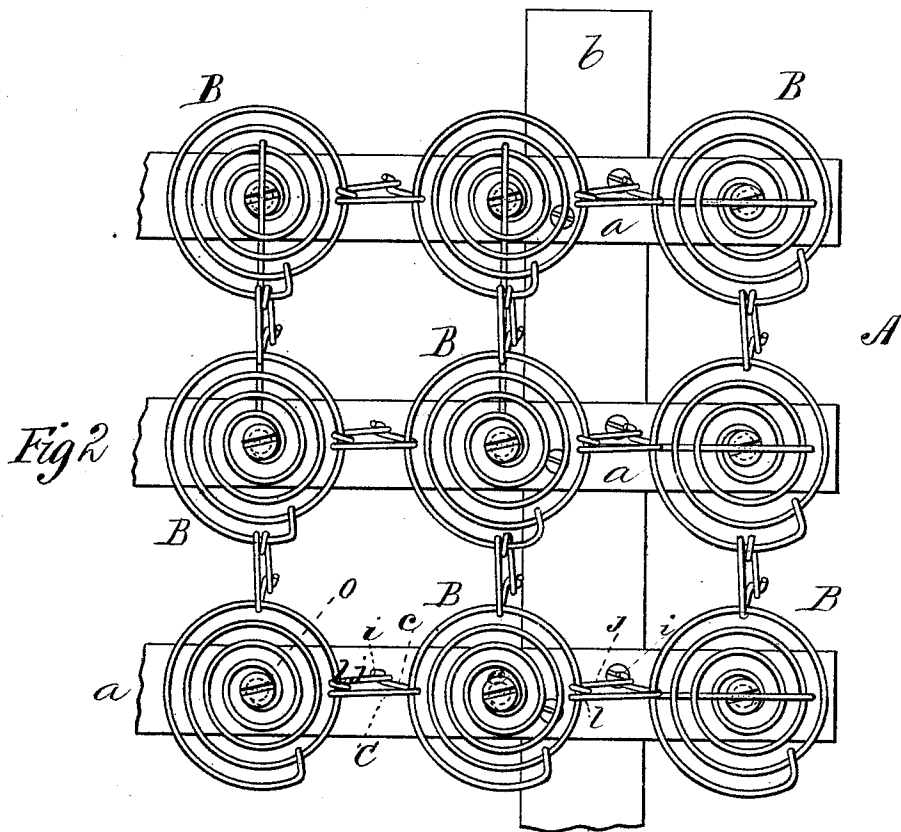
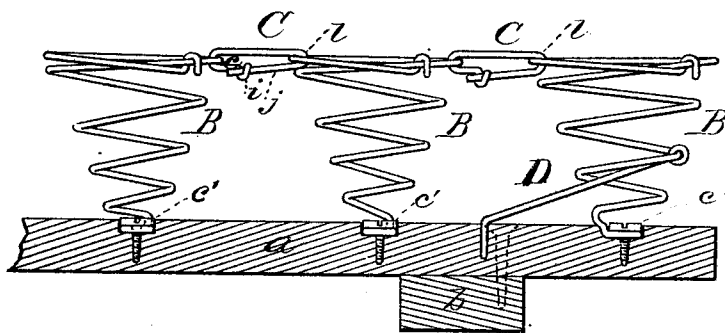

Fig 3



WITNESSES  
*Villette Anderson.*  
*T. J. Masi*

INVENTOR  
*J. R. Newman*  
by *E. W. Anderson*  
ATTORNEY

# UNITED STATES PATENT OFFICE.

JARED R. NEWMAN, OF FRANKLIN, PENNSYLVANIA.

## IMPROVEMENT IN SPRING BED-BOTTOMS.

Specification forming part of Letters Patent No. **180,909**, dated August 8, 1876; application filed July 1, 1876.

*To all whom it may concern:*

Be it known that I, JARED R. NEWMAN, of Franklin, in the county of Venango and State of Pennsylvania, have invented a new and valuable Improvement in Spring Bed-Bottoms; and I do hereby declare that the following is a full, clear, and exact description of the construction and operation of the same, reference being had to the annexed drawings, making a part of this specification, and to the letters and figures of reference marked thereon.

Figure 1 of the drawings is a representation of a bottom view of the bed-frame. Fig. 2 is a top view of the improved spring-bed, showing the spring-links applied; and Fig. 3 is a sectional view of the frame, and a side elevation of the springs, the links, and the stay-rods.

This invention has relation to improvements in spring bed-bottoms; and it consists in a detachable spring-link, consisting of a hook, a coil, and a latch, in combination with the spiral springs of a spring bed-bottom and its frame, as will be hereinafter fully explained.

In the annexed drawings, the letter A designates the frame of my improved spring-bed, consisting of a suitable number of spaced longitudinal bars, *a*, screwed or otherwise secured to transverse slats *b*, of sufficient length to reach from side to side of the bed, and designed to have their ends bear upon cleats secured to the inside of the side rails of the bed.

By this means the usual bed-slats are entirely done away with, and additional flexibility is imparted to the bed-bottom.

The bed is also rendered very easy to clean, and no harbor afforded bugs, and no crevices made in which dirt or dust can accumulate.

B represents the usual spiral springs, which are secured to the rails *a* in the following manner: Their tapered ends are formed in a small coil, *o*, and in the opening of the coil a large-headed wood-screw, *c*, is inserted. Being then forced into the wood, the head will clamp the said coil against the rail *a*, and hold it removably, but rigidly, in position. The end of the uppermost coil of spiral spring B is bent down and twisted around the second coil, thus disarming its ends, and

allowing the mattress to be placed upon the said springs, without danger of tearing the same when being adjusted or removed.

C represents my improved spring-link, made of any suitable wire, and designed to secure the upper part of the springs together. This link is formed of a single piece of wire, in the following manner: One of its ends is bent to form a hook, *c*, which, being accomplished, a catch, *i*, is made by bending the end of the hook outward at right angles to the plane thereof. This hook is engaged with the upper coil of a spring, B, and the other end of the wire passed over and twisted around the corresponding coil of the spring next adjacent, forming a flat coil thereon, a suitable number of times. This end is then bent horizontally, and carried across to catch *i*, and engaged therewith, forming a latch, *j*, which will prevent hook *c* from casual disengagement from spring B. The coil *l*, above described, being composed of two or more coils, will hold the link against rotating horizontally, and bringing the ends of the hook and catch uppermost, the result being the absolute prevention of the tearing of the covering or bed-sack.

D represents a metallic rod of suitable rigidity, secured at one end to one of the middle coils of the outer rows of springs, and at the other to the rails *a* of the bed-frame. This rod is in the nature of a stay, and one of them will be supplied to each spring in the outer end and side rows. Their effect will be to prevent the outer rows of springs, which are least supported and most exposed to strain, from being thrown outward out of the perpendicular. By this means the spring-bed will be kept in shape, and rendered very durable.

What I claim as new, and desire to secure by Letters Patent, is—

The detachable spring-link C, consisting of a hook, *c*, catch *i*, coil *l*, and latch *j*, in combination with the spiral springs B, and a spring-bed frame, substantially as specified.

In testimony that I claim the above I have hereunto subscribed my name in the presence of two witnesses.

JARED R. NEWMAN.

Witnesses:

SAM. B. MYERS,  
L. C. HEASLY.