

J. M. Connel,

Windlass Water Elevator,

N<sup>o</sup> 31,008.

Patented Jan. 1, 1861.

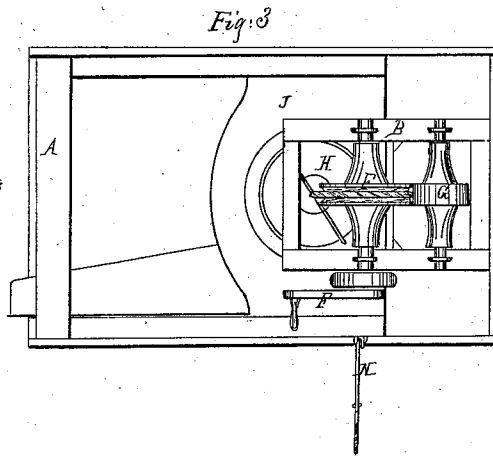
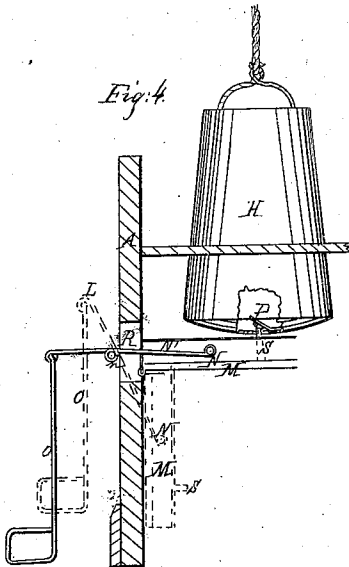
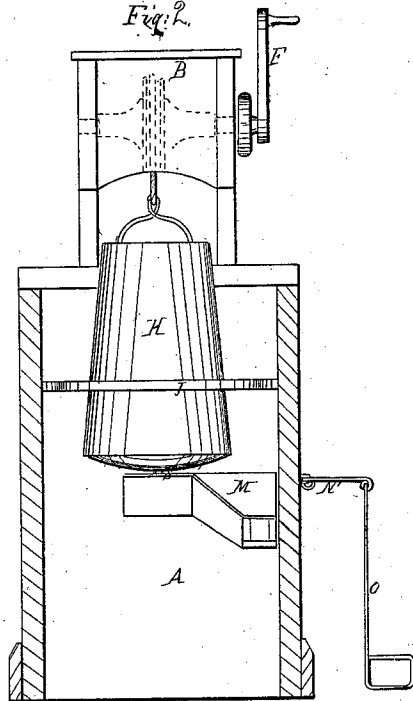
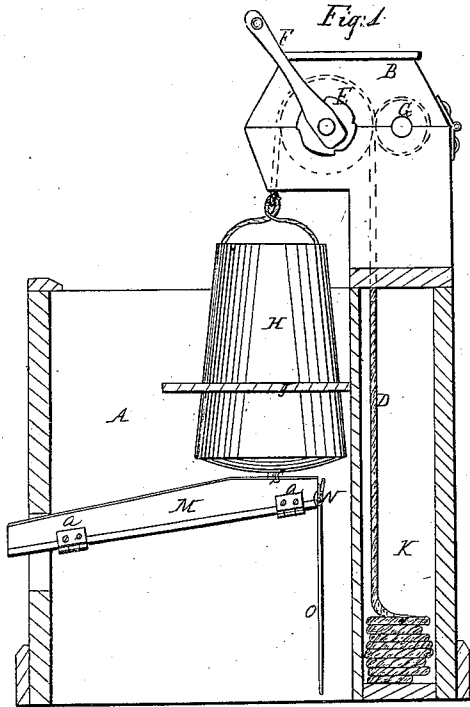

Witnesses:

J. Bramerd  
Bramerd

Inventor:

J. M. Connel

# UNITED STATES PATENT OFFICE.

J. M. CONNELL, OF NEWARK, OHIO.

## WATER-ELEVATOR.

Specification of Letters Patent No. 31,008, dated January 1, 1861.

*To all whom it may concern:*

Be it known that I, J. M. CONNELL, of Newark, in the county of Licking and State of Ohio, have invented certain new and useful  
5 Improvements in Water-Drawers; and I do hereby declare that the following is a full and complete description of the construction and operation of the same, reference being had to the accompanying drawings, making  
10 a part of this specification, in which—

Figures 1, and 2 are vertical sections, Fig. 3 is a view of the top with the cover removed, Fig. 4 is a detached section.

Like letters denote like parts in the different views.

My improvement relates to the manner in which the water is discharged from the bucket, by means of raising the water spout, by foot, or hand power, and bringing it in  
20 contact with the bucket, a stem being attached to the interior of the spout, that opens the valve in the bottom of the bucket.

In the figures A, represents the curb, of  
25 curb. B, the cover hinged to the top of the

H, is the bucket, raised or lowered by means of the rope D, attached to the bail, passing over the pulley E, which is turned  
30 by the crank F.

G, is the compression roller covered with india rubber, or its equivalent that presses against the rope D, the rope passing down into the rope box K.

J, is an aperture board, or division, having a circular opening in it, of sufficient size, to permit the bucket to pass up as far as shown in Figs. 1, and 2, which keeps the bucket steadily in place, the compression roller G, preventing it from slipping down.

M, is an adjustable spout, connected to the side of the curb, by hinges *a, a*, which permits it to be raised or lowered. To the upper end of the spout at N, Figs. 1, and 4, is secured the rod N', that passes through a  
45 slot R, shown in Fig. 4, around the brace *n*, and terminates in a handle, to which is connected the foot piece O, by means of which,

the spout can be raised or lowered, as shown in Fig. 4. When the rod N', is up at L, which is its position when not in use, the  
50 spout is down parallel with the side of the curb, as indicated, but when it is desired to obtain water from the bucket; by depressing the handle the spout is raised, and the upper end is of sufficient width to extend under the  
55 bucket, as shown in Figs. 2, and 4. To the interior of the spout is attached the stem S, that comes in contact with the valve P, in the bottom of the bucket and forces it open, as shown in Fig. 4. With this arrangement  
60 more or less water can be obtained from the bucket, for the pressure of the water in the bucket, would close the valve as soon as the spout was let down, and by opening the valve to a greater or less degree the quantity  
65 of water delivered in a given time can be regulated.

The slot R, through which the handle N', passes, is in the same side of the curb that the crank F, is, so that while the bucket is brought up with one hand, the spout can be  
70 raised with the other, or by placing the foot in the foot piece. It is designed also, when desired, instead of having one end of the rope pass down into the rope box, or chamber  
75 K, to have a bucket attached to that end, and have the spout of sufficient size, and with two stems, so arranged, as to open the valve of whichever bucket is raised.

I contemplate adjusting the shaft of the  
80 compression roller G, by set screws, if found necessary in practice.

What I claim as my improvement and desire to secure by Letters Patent is,

The arrangement of means for actuating  
85 the spout (M), which is hinged to the curb as set forth, for operating the valve (P) and controlling the quantity and the flow of water, in connection with the aperture board (J) as and for the purposes described.

J. M. CONNELL.

Witnesses:

J. BRAINERD,  
S. H. MATHER.