

(No Model.)

4 Sheets—Sheet 1.

J. D. McILWAIN.
OIL TANK CAR.

No. 493,940.

Patented Mar. 21, 1893.

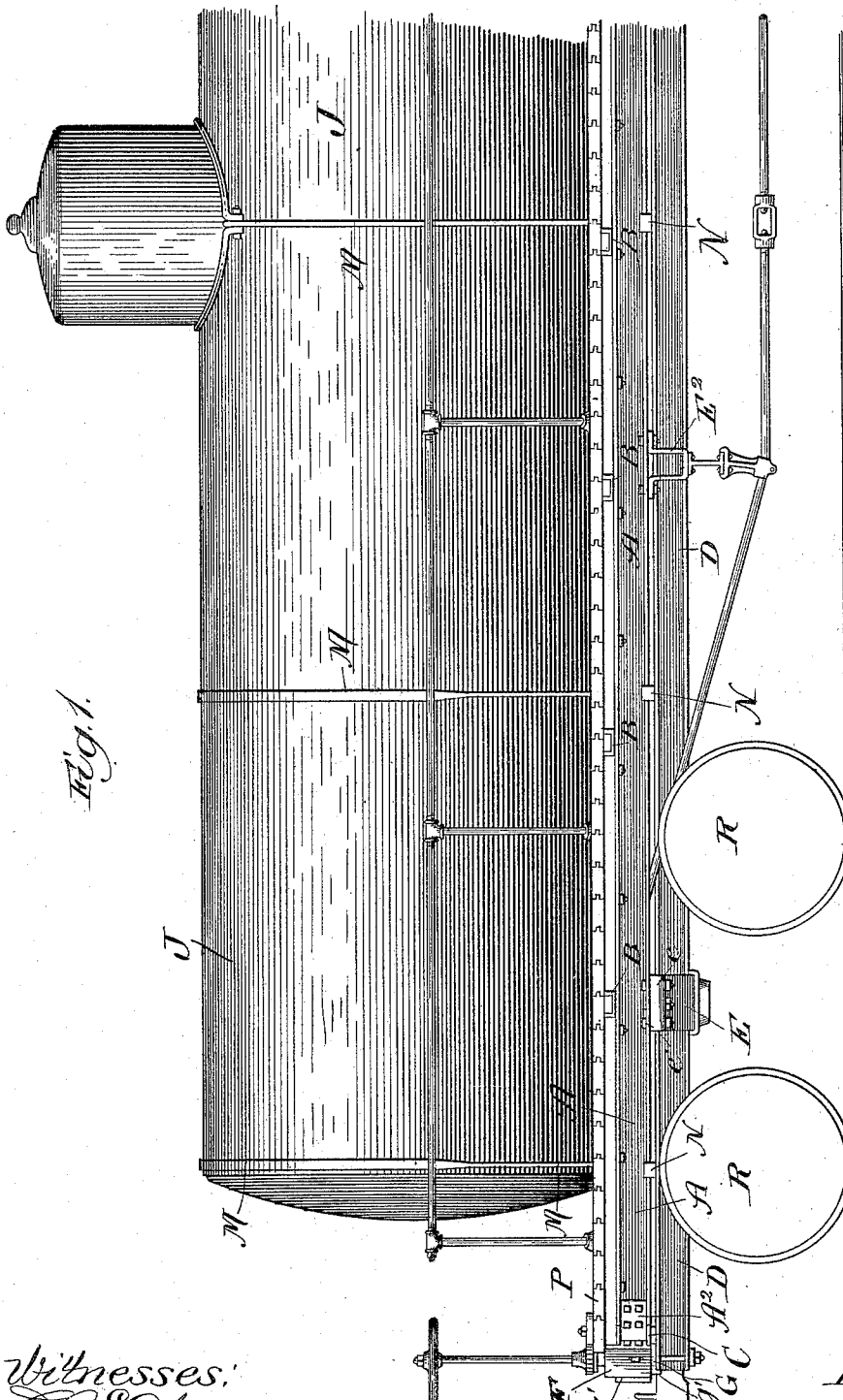

Fig. 1.

Witnesses:
Clayton
Clifford White

Inventor:
 John D. McIlwain
 By *William J. Ramsey* & *William J. Payson*
Attys.

(No Model.)

4 Sheets—Sheet 2.

J. D. McILWAIN.
OIL TANK CAR.

No. 493,940.

Patented Mar. 21, 1893.

Fig. 2.

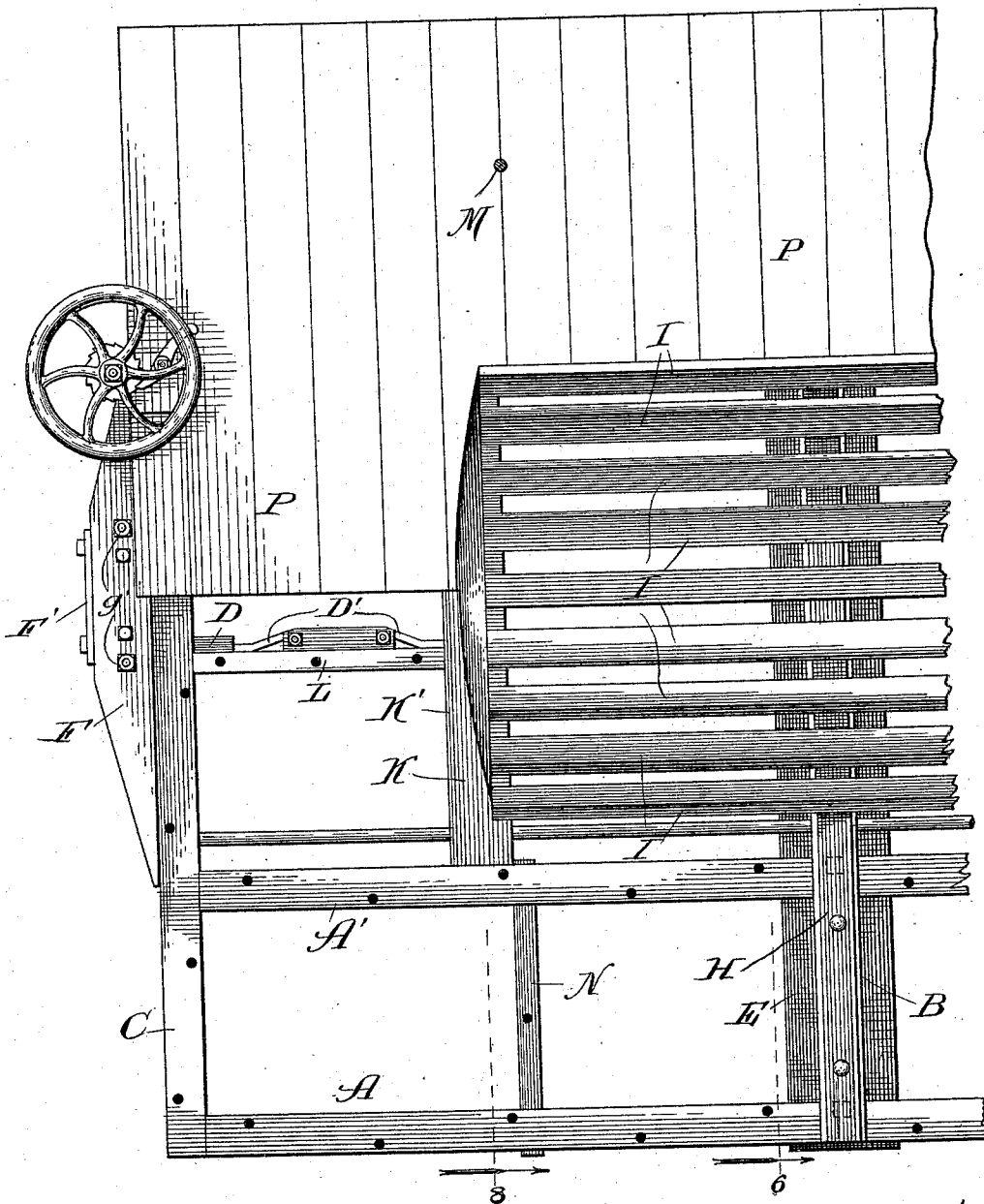

Witnesses:
Chas. C. Sanford,
Clifford White.

Inventor:
 John D. McIlwain
 By *Benjamin D. Benjamin* & *Rayson*
Allis's

(No Model.)

4 Sheets—Sheet 3.

J. D. McILWAIN.
OIL TANK CAR.

No. 493,940.

Patented Mar. 21, 1893.

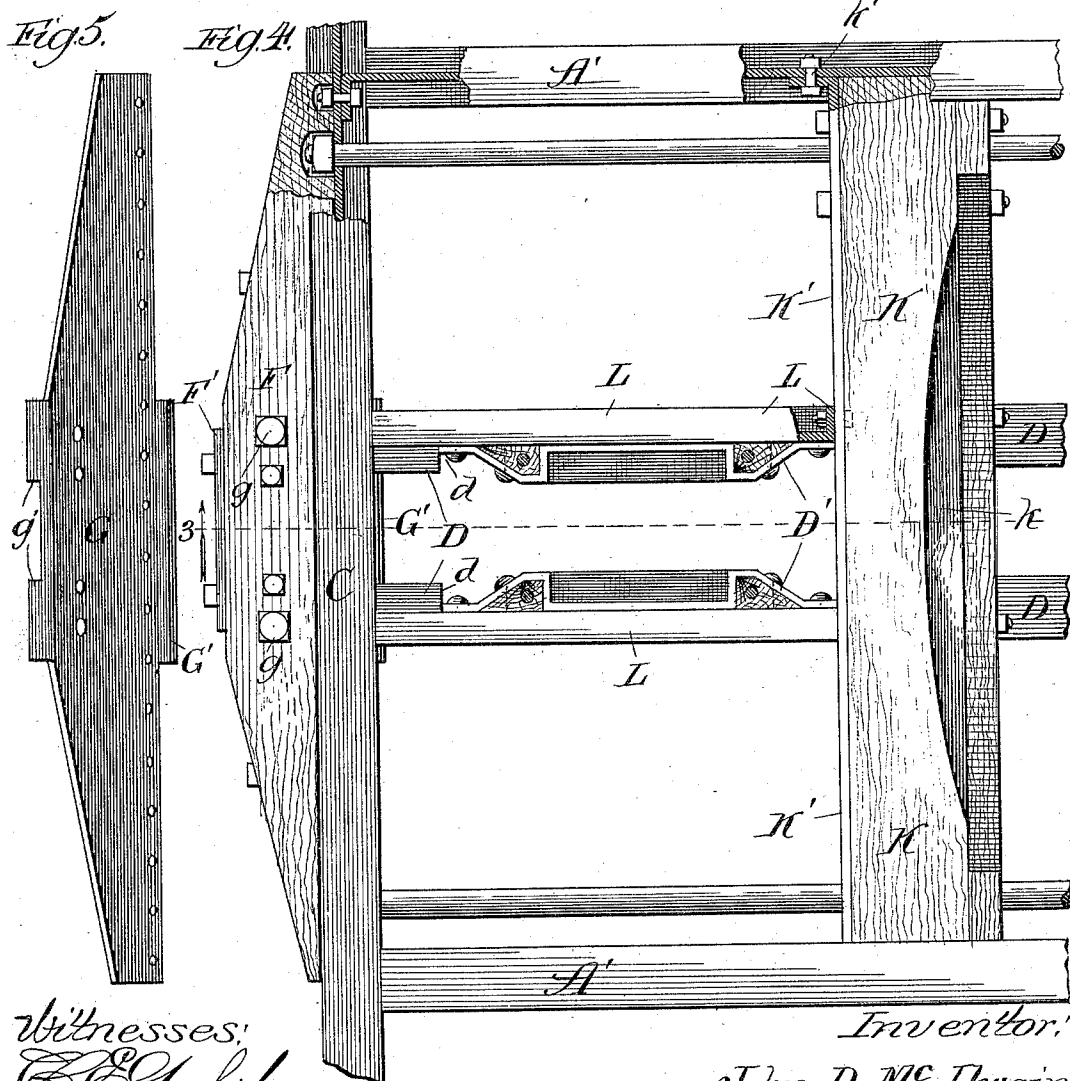
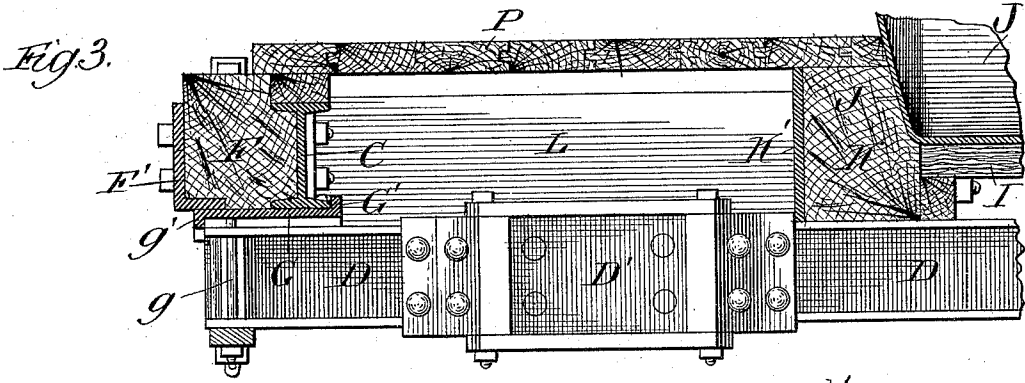

Witnesses:
Edw. Gaylord,
Clifford White.

Inventor:
 John D. McIlwain,
By *Benjamin P. Panning* *Benjamin P. Panning*
Attys.

(No Model.)

4.Sheets—Sheet 4.

J. D. McILWAIN.
OIL TANK CAR.

No. 493,940.

Patented Mar. 21, 1893

Fig. 6.

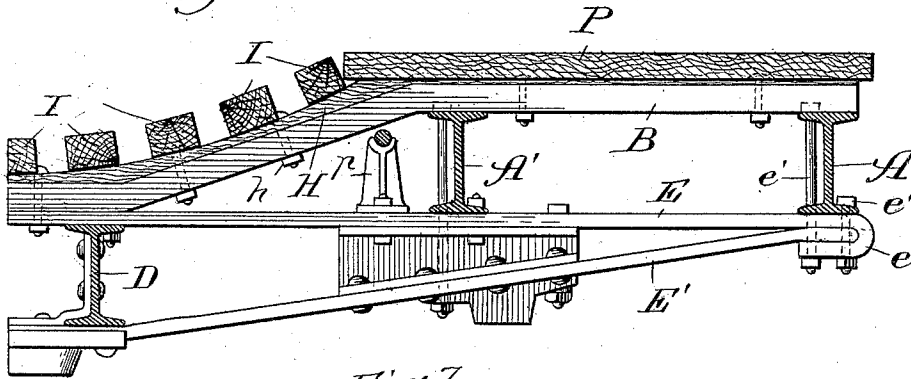

Fig. 7.

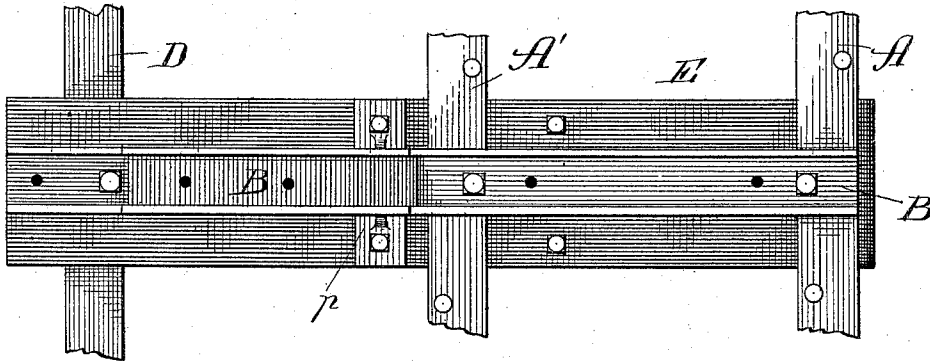

Fig. 9.

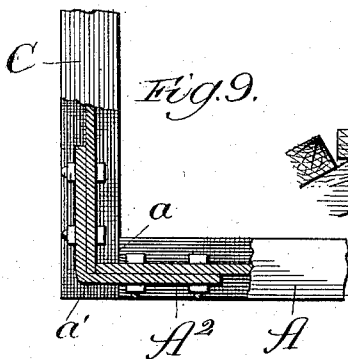
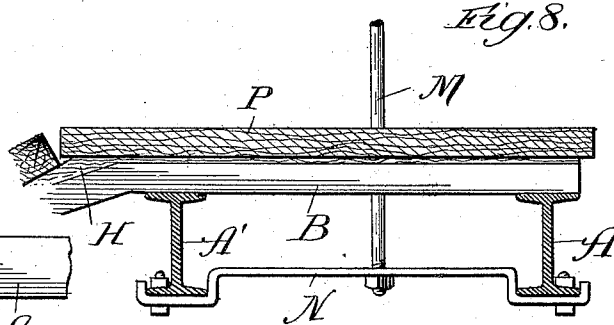

Fig. 8.



Witnesses:

Edw. C. Gaylord,
Clifford N. White.

Inventor:

John D. McIlwain.
By Manning & Manning, Attys.

UNITED STATES PATENT OFFICE.

JOHN D. MCILWAIN, OF CHICAGO, ILLINOIS, ASSIGNOR TO THE HARVEY STEEL CAR AND REPAIR WORKS, OF SAME PLACE.

OIL-TANK CAR.

SPECIFICATION forming part of Letters Patent No. 493,940, dated March 21, 1893.

Application filed September 22, 1892. Serial No. 446,535. (No model.)

To all whom it may concern:

Be it known that I, JOHN D. MCILWAIN, a citizen of the United States, residing at Chicago, Cook county, Illinois, have invented certain new and useful Improvements in Oil-Tank Cars, of which the following is a specification.

The object of my invention is to produce a tank car for the transportation of oil, &c., which shall be an advance in point of simplicity and strength over all cars intended for that purpose with which I am acquainted.

The car which is to be hereinafter described in the specification is composed principally of metal, the parts being so arranged with relation to one another as to produce the greatest firmness and strength, while at the same time the construction is exceedingly simple; and my invention consists in the features, details and combinations hereinafter described and claimed.

In the drawings, Figure 1 is a side elevation of a portion of a tank car embodying my improvements; Fig. 2 a plan view of a portion of one end of such car, the tank and a portion of the flooring being removed; Fig. 3 a section on line 3 of Fig. 4, looking in the direction of the arrow; Fig. 4 a view similar to that shown in Fig. 2, but with the flooring removed and parts of the sills broken away; Fig. 5 a perspective view of an anchor plate; Fig. 6 a section on line 6 of Fig. 2, looking in the direction of the arrow; Fig. 7 a plan view of Fig. 6, several parts shown in that figure being removed; Fig. 8 a section on line 8 of Fig. 2, looking in the direction of the arrow; and Fig. 9 a detail view partly broken away.

The sills A A' of the car are made of I-beams of any suitable dimensions. There are four of these sills in my design—two side sills A and two intermediate sills A'. These sills are connected together by means of two I-beams called end sills C, plates called bolsters E, two I-beams called cross ties E², and steel channel beams B, as shown in elevation in Fig. 1. The end sills C are also made of I-beams, and are attached to the sills A in a manner more particularly shown in Fig. 9. The flanges of the side sills are cut off at right angles, fitting squarely, as shown at a, against the sides of the flanges of the end

sills C. The webs of the two side sills are cut so as to abut squarely against the flange of the end sill, as shown at a'. A plate A², of a breadth substantially the same as that of the web of the sills is bent around the corner, and bolted to the webs of the sills A and C. In this way the sills are rigidly locked together, and the strongest possible connection made between them. The intermediate sills A' are secured to the end sills C, preferably in the manner shown in the upper left hand corner of Fig. 4. The flanges of the intermediate sills are cut off so as to abut against the flanges of the end sill, but the webs of the intermediate sills are continued on until brought into contact with the web of the end sill, when they are turned, as shown, substantially at right angles, resting against and bolted to the web of the end sill.

The center sills D, which form a portion of the draft rigging hereinafter described, are placed below and bolted to the end sills C, as shown in Fig. 3.

The tank is supported on channel beams B placed on and bolted to the top flanges of the main sills of the car. These beams are depressed between the intermediate sills A' to the tops of the center sills D. This depression is shaped to fit the tank. The channel is upmost and in it are bolted wooden fillers H, their upper sides being curved to fit the tank. Secured to these fillers are the longitudinal strips I on which the tank rests.

The draft rigging of this car is formed as follows: D D are the center sills, made of I-beams and extending the entire length of the car, and secured to the end sills, bolster plates, cross ties and channel beams by means of suitable bolts. Portions of the flanges on the inner faces of these center sills are cut away, as shown at d, and in the sockets thus formed are secured draft irons D', which may be of the "Schoon" or any of the other desired forms. In this way is provided a continuous draft rigging, of great strength and simplicity, which consists of the fewest possible number of parts. The couplers D² will of course be secured in the draft rigging in the usual manner, which, inasmuch as it forms no part of my invention, needs no description.

To form the body bolster, a plate E, of steel

or any other suitable material, is run across the car, resting against and suitably secured to the lower flanges of the side sills, intermediate sills, and top flanges of the center or draft sills. It should be understood that in constructing a car, the plate E would naturally first be placed in position, and the center sills then attached, though, of course, in giving this description of the car I am not in any way intending to limit myself to the building of the car in any specified succession of steps, but am giving a description of the various parts, in order that their construction may be clearly comprehended, since when persons skilled in the art are called upon to build this car, they will take the steps in any proper or desired order. A second plate E' is now fastened across the car, passing beneath and secured to the center sills D, and then bent upward with its ends in contact with the under side of the plate E. The ends of this latter plate are then bent around the ends of the plate E', and the two plates firmly fastened to each other and to the side sills by means of bolts e', some of which preferably extend through the lower flange only of the side sill, while the others extend through both flanges and into the beam B.

Attached across the front face of the end sill C is the buffer block F, carrying upon its front face a buffer plate F'. To anchor the end sill and the buffer block and securely tie them together, I provide an anchor plate G, shown in perspective in Fig. 5. This plate is preferably of a length equal to the length of the buffer block. It rests upon the upper faces of the center sills, and is firmly held in place by means of suitable bolts g passing through the buffer block, anchor plate, and the flanges of the center sills, (Fig. 3.) Upon one edge this anchor plate is provided with an upwardly extending shoulder, plate or flange G', which passes inside of and engages with the lower flange of the end sill C, as shown more particularly in Fig. 3. On its other edge it is provided with a downwardly depending flange g', which engages with the ends of the upper flanges of the center sills, this flange g' being preferably recessed, as shown, to provide room for the passage of the draw head. From this construction it results that buffing strains which may be thrown upon the buffer block and end sill will immediately be communicated to and in great part taken up by the center sills, thereby forming a combination most perfectly adapted for the purpose.

The frame of the car having been constructed in the above manner, the parts for supporting the tank may now be described: A description has already been given of the channel beams B, and it is these beams that play an important function in supporting the tank. In the channels of the beams are placed fillers H, preferably of wood, shaped on their lower sides to fit the angles of the beams, and curved on their upper sides to conform to the

shape of the tank, and securely held in the beams by suitable bolts h, or any other means desired forming "tank saddles." Secured to these filler blocks H are the longitudinal strips I, on which the tank J rests, and by which it is directly supported, lateral motion being prevented by these strips and by the straps hereinafter described. Means are also desired for preventing any longitudinal motion or undue jarring of the tank, and to this end I provide the car with tank stops constructed in the following manner. Extending across the car, held in place between the intermediate sills A', is a block K, one of these blocks being placed at each end of the tank. This block is suitably curved or hollowed out, as at k, to fit the curvature at the end of the tank, as shown in Figs. 2 and 3. In contact with the forward side of the block K is a plate K', of steel or other suitable material, which extends across the car from one intermediate sill to the other, and is bolted at the ends, as shown at k', to the webs of the intermediate sills A'. To more firmly secure this plate, I place between it and the end sills C short sills L, of channel iron, these sills being secured to the top of the draft sills D. In this way, the tank stops and end sills are firmly secured together, and the end sills being anchored as already described to the draft rigging, the whole frame of the car acts together to resist shocks.

The straps M, which pass over the tank and assist in holding it in place, pass down as shown through the floor of the car, and are secured at their lower ends to plates N, bolted to the lower flanges of the side sills and intermediate sills, thereby forming a secure anchoring for the ends of these straps, this detail of construction being shown more particularly in Fig. 8. The plates N assist in securely binding the sills A and A' together.

The car may be provided with suitable flooring P, and of course is supported upon the proper trucks and wheels, the trucks not being shown, but the wheels being conventionally indicated in Fig. 1, and lettered R. Moreover it is evident that many parts of my invention may be used with other cars than those intended for transporting oil tanks, and I contemplate so using them.

In this way I provide a tank car which possesses more advantages than any other with which I am acquainted, and which, while simple in construction, is possessed of great strength, inasmuch as the various parts are so placed relatively, and secured to each other, that they will co-operate to the fullest extent possible, so that a shock or jar upon one portion of the car need not be borne by that portion alone, but is communicated to and taken up by the entire framework, whereby the effect of the shock is dissipated, and the liability to injury greatly lessened. Also the different parts are so combined that any part can be moved for repairs or renewed with the least possible labor and expense.

I claim—

1. In a tank car, the combination of **I**-beam center sills extending the entire length of the car, and draft irons secured to the sills at suitable points, forming a continuous draft rigging, substantially as described.

2. In a tank car, the combination of **I**-beam center sills, a portion of the flanges of such sills being cut away to form sockets, and draft irons secured in such sockets, substantially as described.

3. In a tank car, the combination of **I**-beam center sills, and an **I**-beam end sill with an anchor plate provided with flanges engaging with both the end and center sills to lock them together, whereby any strain upon the end sill is communicated to and taken up by the center sills, substantially as described.

4. The combination of an **I**-beam end sill, a buffer block secured thereto, **I**-beam center sills, and an anchor plate provided with two flanges, one extending upward to engage with the flange on the end sill, and the other extending downward to engage with the flanges of the center sills, substantially as described.

5. In a tank car, the combination of intermediate sills, **I**-beam center sills extending the entire length of the car, end sills secured to the intermediate sills, blocks K, and short sills interposed between the end sills and the blocks and resting upon and secured to the center sills, whereby the tank stops at each end of the tank are rigidly connected, substantially as described.

6. In a tank car, the combination of intermediate sills, an end sill secured to the intermediate sills, a block K, a plate secured to the side sills in front of the block, and short sills interposed between and secured to the end sill and the plate, thereby forming a stop for the tank, substantially as described.

7. In a tank car, a tank saddle composed of channel iron cross beams placed at suitable distances apart to properly support the tank and conforming substantially to the shape of the tank, and fillers placed within and supported by the channel beams, substantially as described.

8. In a tank car, the combination of **I**-beam

side sills, channel iron cross beams secured to the upper flanges of such sills and bent to conform to the shape of the tank, wooden filler blocks carried in and supported by such channel beams, longitudinal strips **I**, and a tank resting upon such strips, substantially as described.

9. In a tank car, the combination of **I**-beam intermediate sills, a plate **E** secured to such sills, center sills secured beneath such plate, and a plate **E'** contacting with the lower faces of such center sills with its ends brought in contact with the plate **E**, the ends of such latter plate being bent around the ends of the plate **E'** and the ends secured to each other and to the side sills by suitable means, substantially as described.

10. In a tank car, the combination of **I**-beam side sills, **I**-beam end sills, the flanges of the side sills being cut off to abut squarely against the flanges of the end sills, the webs of the side sills being extended into contact with the web of the end sill, and a plate **A** bent around and secured to the webs and locking the sills together, substantially as described.

11. A tank car frame comprising **I**-beam side and intermediate sills, **I**-beam center sills, plate bolsters attached to such side, intermediate and center sills, and channel iron cross beams secured to the upper flanges of the center sills and bent to conform substantially to the shape of the tank, substantially as described.

12. The combination of **I**-beam side sills, channel iron cross beams secured thereto and bent to conform to the shape of the tank, fillers resting in and supported by such channel beams, longitudinal strips secured to the fillers, a tank resting upon such strips, and retaining straps passed around such tank, the ends of the straps being held by anchor plates engaging with the lower flanges of the side and intermediate sills, substantially as described.

JOHN D. McILWAIN.

Witnesses:

GEORGE S. PAYSON,
SAMUEL E. HIBBEN.