



(12) **EUROPEAN PATENT APPLICATION**

(43) Date of publication:
27.09.2000 Bulletin 2000/39

(51) Int Cl.7: **F04D 29/44**

(21) Application number: **00660054.8**

(22) Date of filing: **21.03.2000**

(84) Designated Contracting States:
**AT BE CH CY DE DK ES FI FR GB GR IE IT LI LU
 MC NL PT SE**
 Designated Extension States:
AL LT LV MK RO SI

(72) Inventors:
 • **Sjöqvist, Lennart**
56434 Bankeryd (SE)
 • **Henningsson, Jan Erik**
56148 Huskvarna (SE)

(30) Priority: **22.03.1999 FI 990637**

(74) Representative:
Valkeiskangas, Tapio Lassi Paavali et al
Oy Kolster Ab,
Iso Roobertinkatu 23,
P.O. Box 148
00121 Helsinki (FI)

(71) Applicant: **ABB FLÄKT OY**
SF-20520 Turku (FI)

(54) **Fan diffuser**

(57) The invention relates to an arrangement in connection with a fan comprising a rotatable fan wheel (1) and a diffuser (2) arranged in connection with the fan wheel to convert kinetic energy generated by a high velocity of exhaust into static pressure. In order to eliminate a disturbing reflow, at least one of side plates (2a, 2b) of the diffuser (2) is arranged to overlap with the outer edge of the rim of the fan wheel (1).

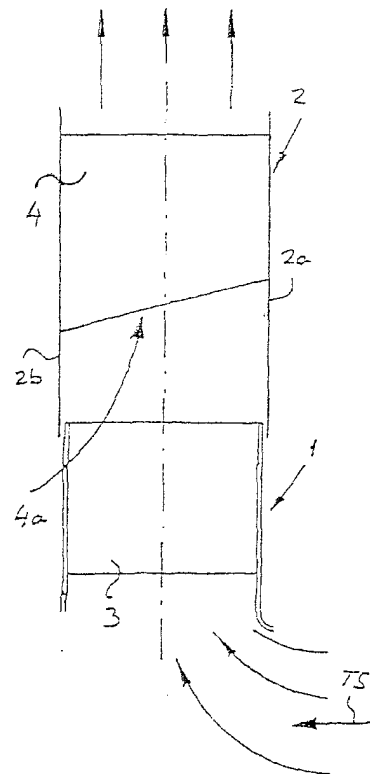

FIG. 5

Description

[0001] The invention relates to an arrangement in connection with a fan comprising a rotatable fan wheel and a diffuser arranged in connection with the fan wheel to convert kinetic energy generated by a high velocity of exhaust into static pressure.

[0002] The above-mentioned arrangements are well-known today in connection with, for example, different fan applications used in air treatment. The purpose of a diffuser arranged after a fan wheel in the direction of flow is to convert the dynamic pressure generated by a high velocity of exhaust of the fan wheel into static pressure. This can be achieved by lowering the high velocity of exhaust after the fan wheel by the diffuser.

[0003] Dimensioning of a diffuser is a widely-studied subject. *Design and Operation of Centrifugal Axial-Flow and Cross-Flow Fans* by B. Eck, a well-known study in the field, provides an example of the dimensioning of blades and passages of a diffuser. Designing the diffuser optimally, however, usually results in a blade having the shape of a logarithmic spiral, which is difficult and expensive to manufacture from sheet metal; consequently, manufacturing costs easily become too high. In order to reduce the manufacturing costs, an attempt has been made to restrict the number of the blades to be smaller than the optimal one, in which case, however, flow-technical characteristics suffer and the result is not the best possible one.

[0004] It is also known in the field that the distance between a blade of the fan and the diffuser affects certain characteristics of the apparatus, noise in particular, such that when the distance is too short the noise level is high. The above-mentioned features are also disclosed in the study by B. Eck mentioned above. The distance also has a great effect on the disturbing reflow.

[0005] An object of the invention is to provide an arrangement to enable drawbacks of the prior art to be eliminated. This is achieved by an arrangement of the invention. The arrangement of the invention is characterized in that at least one of the side plates of the diffuser is arranged to overlap with the outer edge of the rim of the fan wheel.

[0006] An advantage of the arrangement of the invention is mainly that it enables all the above-mentioned drawbacks to be substantially efficiently affected and a preferable result to be achieved. A further advantage of the invention is its simplicity, which means that the invention is inexpensive to manufacture and use. A still further advantage of the invention is its flexibility in use, whereby an arrangement of the invention can be preferably applied to different fans.

[0007] In the following, the invention will be described by means of the examples shown in the accompanying drawings, in which

Figure 1 is a schematic view showing how a flow behaves in an apparatus of the prior art,

Figure 2 is a schematic side view of an arrangement of the invention,

Figure 3 is a schematic view of an embodiment of the arrangement of Figure 2 as seen from another direction,

Figure 4 shows a second embodiment of the arrangement of Figure 2,

Figure 5 shows a third embodiment of the arrangement of Figure 2,

Figure 6 is a schematic view of an embodiment of a basic principle of the invention, and

Figure 7 is a schematic view of a second embodiment of the basic principle of the invention.

[0008] Figure 1 schematically shows how a flow of a gaseous medium, such as air, behaves in a fan apparatus of the prior art. In Figure 1, reference number 1 refers to a fan wheel and reference number 2 to a diffuser by which, as stated above, kinetic energy generated by a high velocity of exhaust is converted into static pressure. The fan wheel is rotated by an appropriate motor, such as an electric motor. The motor is not shown in the figure. The flow of air is indicated in Figure 1 by means of arrows, whereby the above-mentioned disturbing reflow is also clearly apparent. In addition to the reflow, the solution of Figure 1 suffers from the disadvantages relating to the noise level, as stated above.

[0009] Figure 2 schematically shows an arrangement of the invention. In Figure 2, the same reference numbers have the same significance as in Figure 1. Furthermore, in Figure 2, the direction of rotation of the fan wheel 1 has been indicated by arrow N. Furthermore, high and low flow rates of air, which are used to describe the basis of operation of the diffuser, in other words the above-mentioned conversion of kinetic energy into static pressure, have also been denoted in Figure 2 by arrows NK and NM.

[0010] Figure 2 further clearly shows blades 3 of the fan wheel and blades 4 located in a diffuser of the present embodiment, the blades 4 of the diffuser being arranged between two side plates 2a, 2b located at a distance from each other, as can be seen from Figures 3 to 5.

[0011] In accordance with the basic idea of the invention, at least one of the side plates 2a, 2b of the diffuser is arranged to overlap with the outer edge of the rim of the fan wheel 1. The above-mentioned essential feature of the invention is clearly apparent in Figure 2 wherein the outer rim of the fan wheel 1 is indicated in a dotted line and the edge of the side plate of the diffuser is indicated in a continuous line. This can also be clearly seen in Figure 3 to 5. The above-mentioned essential feature of the invention also becomes apparent in Figures 6 and 7. In Figures 3 to 5 and 6 and 7, the flow of air is schematically indicated by means of arrows. The above-described structure enables the harmful reflow mentioned earlier to be avoided and the problems related to the noise level to be mitigated.

[0012] The best result is achieved in such a manner that both side plates of the diffuser 2 are arranged to overlap with the outer edge of the rim of the fan wheel, as shown in Figures 3 to 6, for example. The invention can, however, also be applied such that only one of the sides of the diffuser overlaps with the rim of the fan wheel. Such an application is schematically shown in Figure 7 wherein only the side plate 2b of the diffuser is arranged to overlap with the outer edge of the rim of the fan wheel. The structure of Figure 7 yields a slightly poorer result than, for example, the arrangement of Figure 6, but the solution of Figure 7 is advantageous to installability since the diffuser can be a simple, uniform structure which can be installed in place from the side. The overlapping side plate can be either one of the side plates 2a, 2b in this application. In the case of Figure 6, the structure of the diffuser must be a structure which can be opened, for example.

[0013] The invention can be applied in connection with different diffuser solutions, as shown in Figures 2 to 5. Figure 2 shows the blades 4 located in the diffuser that are constructed from straight parts. The straightness of the blades 4 is apparent in Figure 2. The straight blades 4 are an advantage in the manufacturing process. The blades 4 of the diffuser can be shaped in many different ways, as shown in Figures 3 to 5. In the application of Figure 3, sides 4a of the blades 4 of the diffuser facing the fan wheel are straight. In the applications of Figures 4 and 5, the sides of the blades 4 facing the fan wheel are bevelled. In the application of Figure 5, the sides 4a are sloped seen in the direction of incoming air such that the edge of the diffuser facing the front side plate 2a is located at a greater distance from the fan wheel 1 than the edge facing the side plate 2b located further back. The term "seen in the direction of incoming air" refers to the direction of the rotation axis of the fan wheel 1 seen from the side of the fan wherefrom air flows to the fan wheel. This direction is marked with arrows TS in Figures 3 to 5. The flow of air is indicated by arrows. In the application of Figure 4, the blades 4 are bevelled in an inverted manner compared with the application of Figure 5. The most preferable result is achieved with the application of Figure 5.

[0014] The examples disclosed above are by no means meant to restrict the invention but it can be freely modified within the scope of the claims. It is thus obvious that an arrangement of the invention or the details thereof do not necessarily have to be identical to those shown in the figures, but other solutions are also possible. For example, the number of the blades of the diffuser may vary, the type of the fan may be different, etc. The invention can also be applied to a bladeless diffuser, etc.

in connection with the fan wheel to convert kinetic energy generated by a high velocity of exhaust into static pressure, **characterized** in that at least one of the side plates (2a, 2b) of the diffuser (2) is arranged to overlap with the outer edge of the rim of the fan wheel (1).

2. An arrangement as claimed in claim 1, **characterized** in that both side plates (2a, 2b) of the diffuser (2) are arranged to overlap with the outer edge of the rim of the fan wheel (1).
3. An arrangement as claimed in claim 1 or 2, **characterized** in that blades (4) of the diffuser (2) are made from straight parts.
4. An arrangement as claimed in claim 3, **characterized** in that the sides of the blades (4) of the diffuser (2) facing the fan wheel are bevelled.
5. An arrangement as claimed in claim 4, **characterized** in that the sides of the blades (4) of the diffuser (2) are bevelled, as seen in the direction of incoming air, such that the edge of the diffuser (2) facing the front side plate (2a) is located at a greater distance from the fan wheel (1) than the edge facing the side plate (2b) located further back.

Claims

1. An arrangement in connection with a fan comprising a rotatable fan wheel (1) and a diffuser (2) arranged

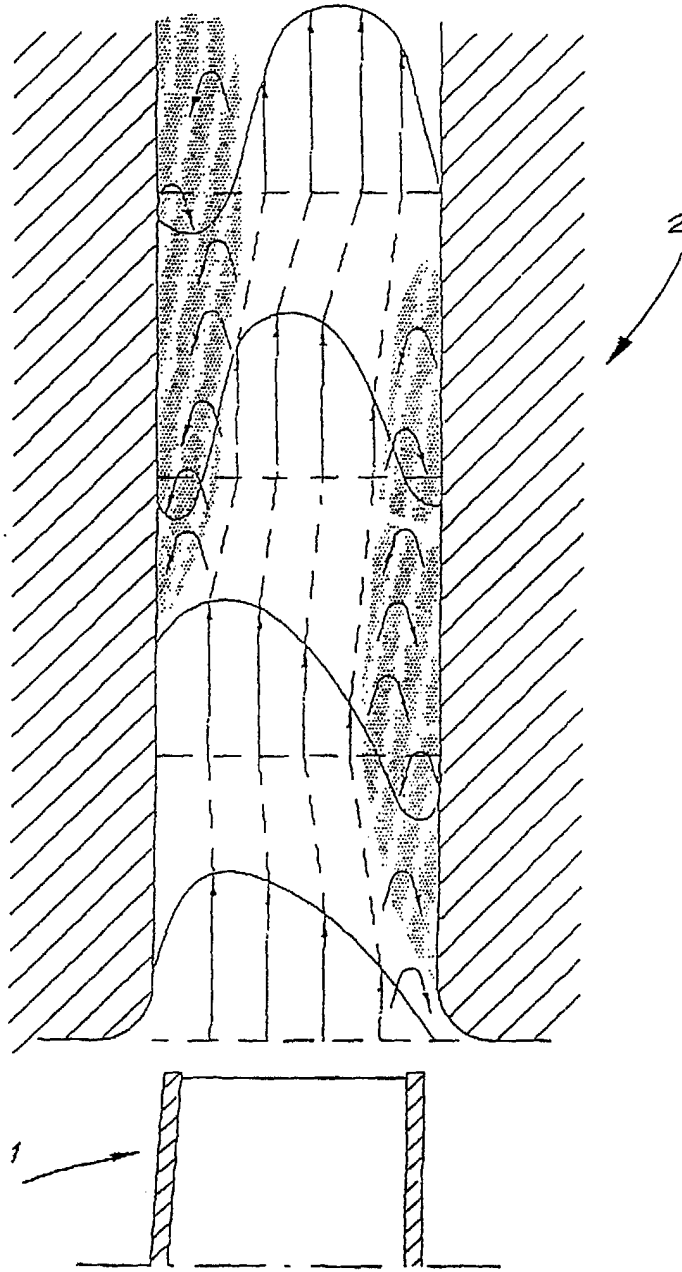

FIG. 1

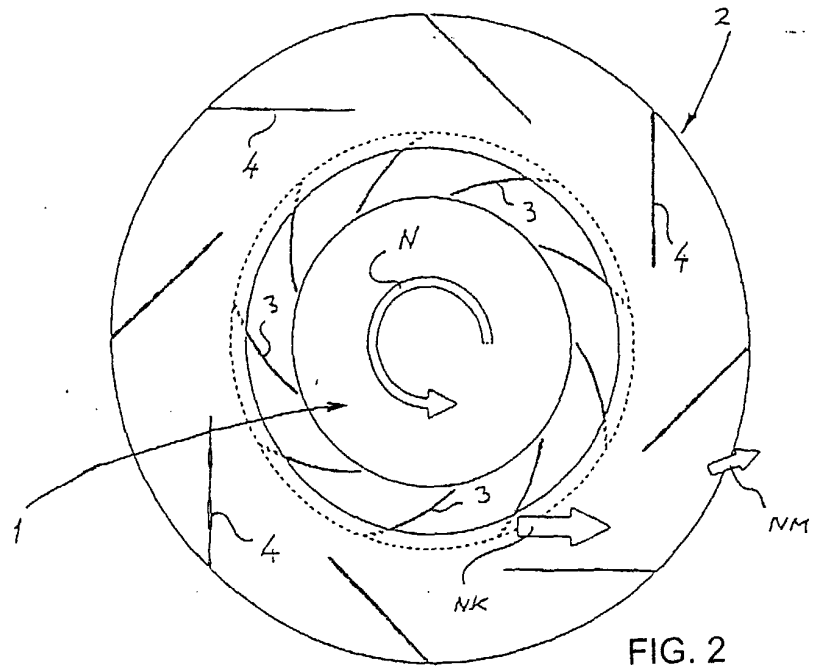

FIG. 2

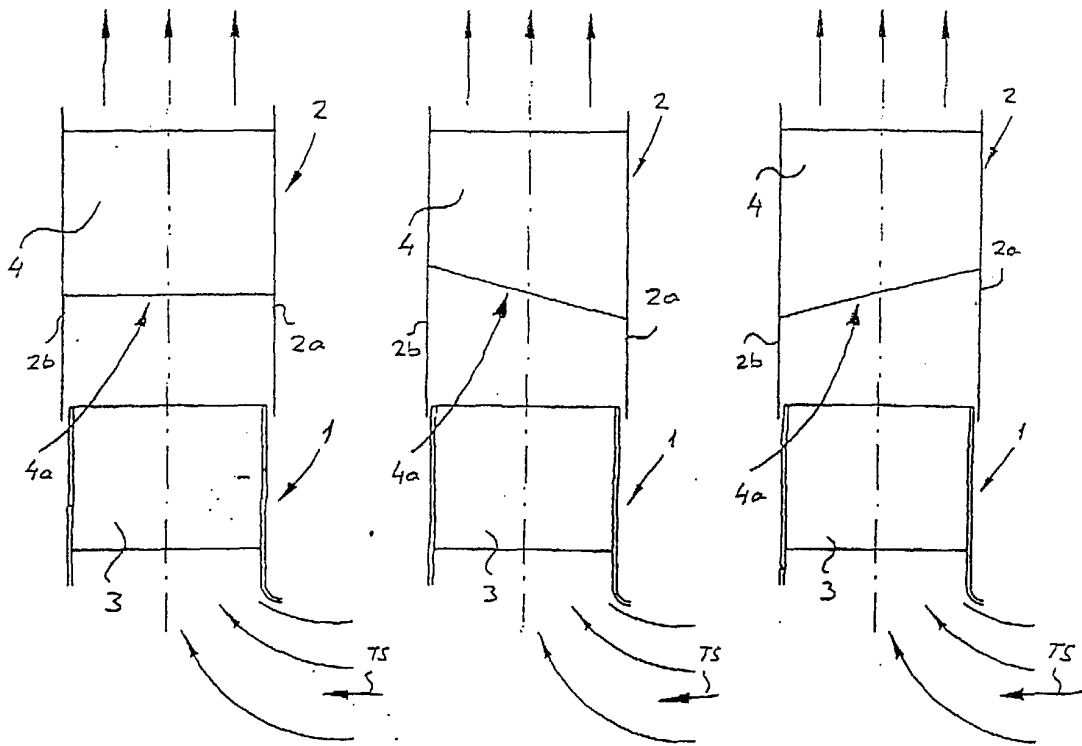

FIG. 3

FIG. 4

FIG. 5

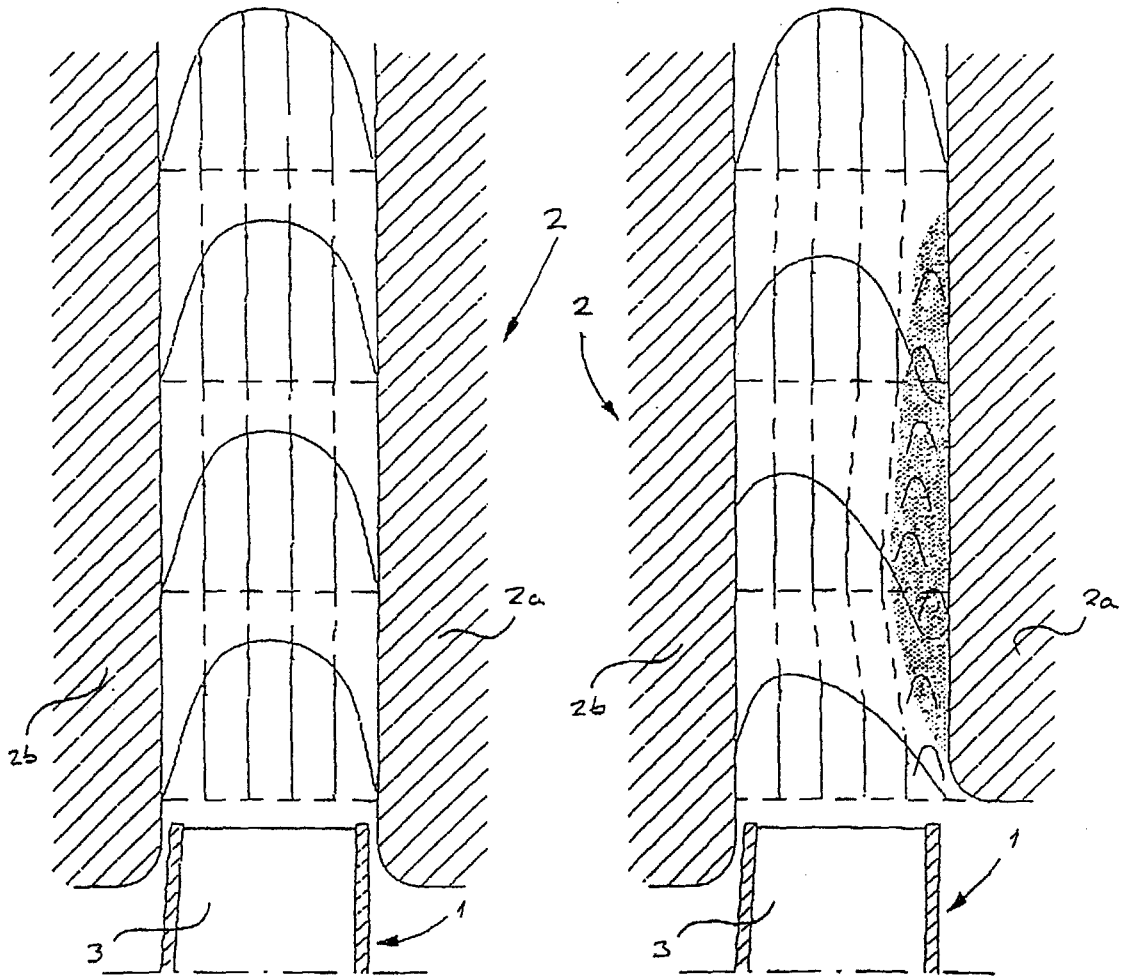

FIG. 6

FIG. 7