

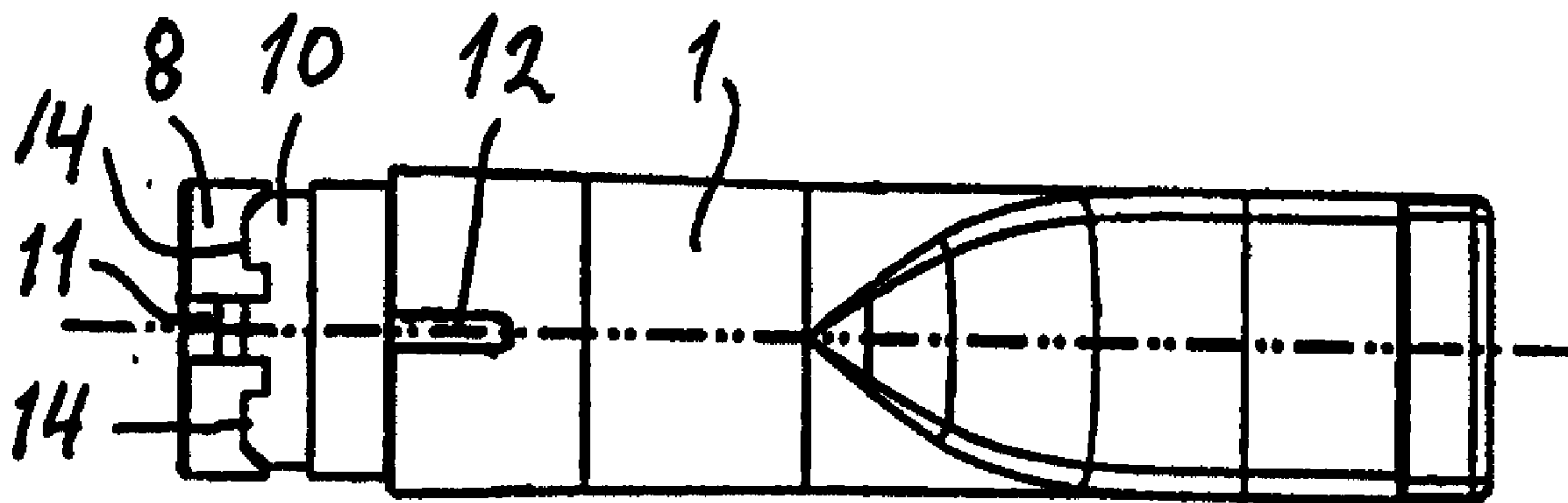

(86) Date de dépôt PCT/PCT Filing Date: 1998/05/22  
 (87) Date publication PCT/PCT Publication Date: 1999/02/04  
 (45) Date de délivrance/Issue Date: 2007/07/10  
 (85) Entrée phase nationale/National Entry: 2000/01/04  
 (86) N° demande PCT/PCT Application No.: SE 1998/000959  
 (87) N° publication PCT/PCT Publication No.: 1999/004840  
 (30) Priorité/Priority: 1997/07/25 (SE9702796-5)

(51) Cl.Int./Int.Cl. *A61M 15/00* (2006.01),  
*A61M 11/00* (2006.01), *B65D 50/00* (2006.01),  
*A61M 15/06* (2006.01)  
 (72) Inventeurs/Inventors:  
 LEVANDER, GUSTAV, SE;  
 FORSELL, FREDRIK, SE;  
 SJOGREN, JESPER, SE  
 (73) Propriétaire/Owner:  
 MCNEIL AB, SE  
 (74) Agent: GOWLING LAFLEUR HENDERSON LLP

(54) Titre : DISPOSITIF D'UN CONTENANT PHARMACEUTIQUE OU INHALEUR  
 (54) Title: A DEVICE AT A PHARMACEUTICAL CONTAINER OR INHALER



(57) Abrégé/Abstract:

A pharmaceutical inhaler has a mouthpiece (1) and a cap (2), which are rotatably connected to each other. For providing a certain child-resistance against disconnection, the mouthpiece is provided with an external circumferential groove (10), whereas the cap is provided with an internal boss (9) for engagement with the groove. There is an axial notch (11) from the groove (10) to the end of the mouthpiece, and "traps" for the boss in the form of recesses (14) on the groove are provided at either side of the notch.

PCT

WORLD INTELLECTUAL PROPERTY ORGANIZATION  
International Bureau

## INTERNATIONAL APPLICATION PUBLISHED UNDER THE PATENT COOPERATION TREATY (PCT)

<p>(51) International Patent Classification <sup>6</sup> : A61M 15/00, 11/00, B65D 50/00</p>	A1	<p>(11) International Publication Number: <b>WO 99/04840</b></p> <p>(43) International Publication Date: 4 February 1999 (04.02.99)</p>
<p>(21) International Application Number: PCT/SE98/00959</p> <p>(22) International Filing Date: 22 May 1998 (22.05.98)</p> <p>(30) Priority Data: 9702796-5                      25 July 1997 (25.07.97)                      SE</p> <p>(71) Applicant (for all designated States except US): PHARMACIA &amp; UPJOHN AB [SE/SE]; S-112 87 Stockholm (SE).</p> <p>(72) Inventors; and (75) Inventors/Applicants (for US only): LEVANDER, Gustav [SE/SE]; Drottninggatan 118, S-252 22 Helsingborg (SE). FORSSELL, Fredrik [SE/SE]; Lilla Bergaliden 3, S-252 23 Helsingborg (SE). SJÖGREN, Jesper [SE/SE]; Bruksgatan 42, S-252 24 Helsingborg (SE).</p> <p>(74) Agent: HEDENSTRÖM, John; Pharmacia &amp; Upjohn AB, P.O. Box 941, S-251 09 Helsingborg (SE).</p>		<p>(81) Designated States: AL, AM, AT, AU, AZ, BA, BB, BG, BR, BY, CA, CH, CN, CU, CZ, DE, DK, EE, ES, FI, GB, GE, GH, GM, GW, HU, ID, IL, IS, JP, KE, KG, KP, KR, KZ, LC, LK, LR, LS, LT, LU, LV, MD, MG, MK, MN, MW, MX, NO, NZ, PL, PT, RO, RU, SD, SE, SG, SI, SK, SL, TJ, TM, TR, TT, UA, UG, US, UZ, VN, YU, ZW, ARIPO patent (GH, GM, KE, LS, MW, SD, SZ, UG, ZW), Eurasian patent (AM, AZ, BY, KG, KZ, MD, RU, TJ, TM), European patent (AT, BE, CH, CY, DE, DK, ES, FI, FR, GB, GR, IE, IT, LU, MC, NL, PT, SE), OAPI patent (BF, BJ, CF, CG, CI, CM, GA, GN, ML, MR, NE, SN, TD, TG).</p> <p><b>Published</b> With international search report.</p>

(54) Title: A DEVICE AT A PHARMACEUTICAL CONTAINER OR INHALER

## (57) Abstract

A pharmaceutical inhaler has a mouthpiece (1) and a cap (2), which are rotatably connected to each other. For providing a certain child-resistancy against disconnection, the mouthpiece is provided with an external circumferential groove (10), whereas the cap is provided with an internal boss (9) for engagement with the groove. There is an axial notch (11) from the groove (10) to the end of the mouthpiece, and "traps" for the boss in the form of recesses (14) on the groove are provided at either side of the notch.

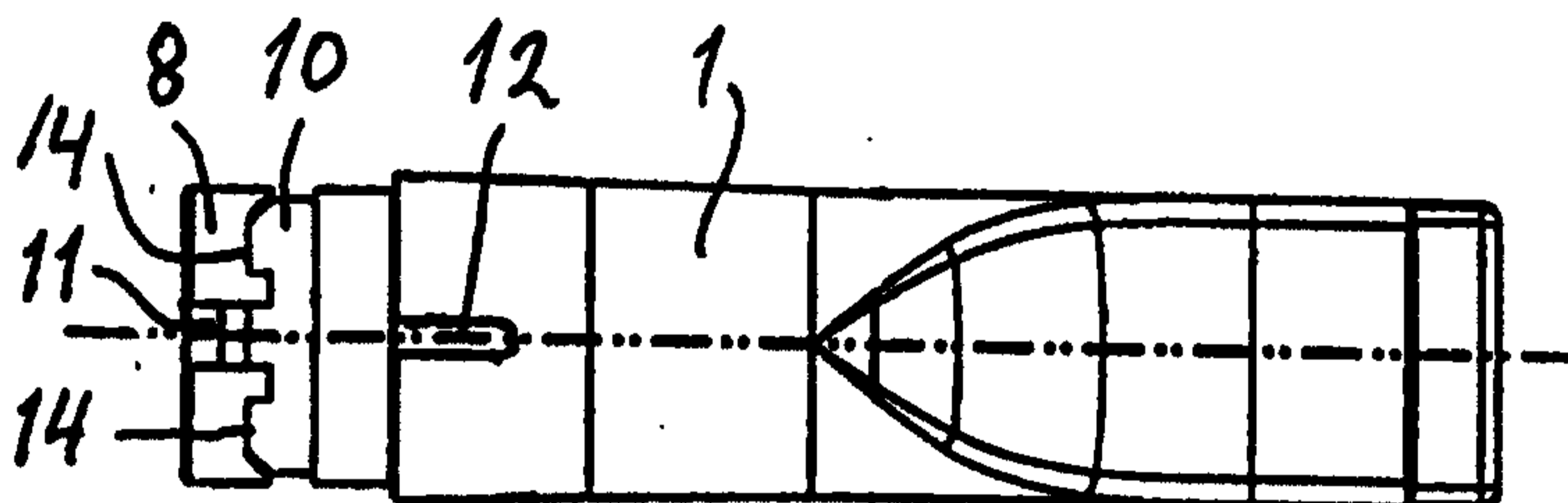

## A DEVICE AT A PHARMACEUTICAL CONTAINER OR INHALER

---

### Technical Field

The present invention relates to a device at a pharmaceutical container or in-  
5 haler for preventing an easy pulling apart of two connected, mutually rotatable members  
having circular cross sections, at least in the connection areas.

### Background of the Invention

It is of great importance that children do not easily get access to the interior of a  
container or bottle of pills or of an inhaler (which is of special relevancy in the present  
10 case), as the contents of such a container or inhaler can be dangerous for children. An  
inhaler may for example hold a nicotine containing ampoule, used to administer nicotine  
to a person, who is trying to abandon the habit of smoking cigarettes. The nicotine is  
very harmful for children.

When the two mutually rotatable members of the inhaler have been connected  
15 or assembled (after an ampoule have been inserted therein), it shall preferably be difficult  
or even virtually impossible for a child to disconnect or disassemble the two members by  
pulling them apart, but at the same time it shall not be too cumbersome for an adult to  
disassemble and then assemble the two parts.

Some devices for accomplishing the above objectives are known, one example  
20 being the one shown and described in NO-B-158 214, in which a bayonet-type connec-  
tion is used.

The object of the present invention is to obtain a design for the above purpose,  
which will be easy to handle for an adult but virtually impossible for a child, at the same  
time as it shall be sturdy and inexpensive to manufacture, for example in a plastic mate-  
25 rial.

### The Invention

These and other objectives are according to the invention for a general case  
obtained in

that a first member towards its end intended for connection with a second mem-  
30 ber is provided with a groove extending in the circumferential direction,

that the second member towards its end intended for connection with the first  
member is provided with at least one boss for engagement with the groove,

that the first member is provided with at least one axial notch from the groove to the end of the first member, and

that the groove in the vicinity of each notch is provided with at least one primary recess in the side in which the notch commences.

5 Normally, only one boss and one notch are provided, but an improved safety can be obtained, if several bosses and notches with different pitches are provided, so that only one of several mutual positions of the two rotatable members is the correct one for pulling them apart.

10 By this design (with one boss and one notch) the two members may be easily assembled or connected by pushing them together with the boss in the notch, whereupon they are turned in relation to each other with the boss in the groove. A following attempt to disconnect or disassemble the members by pulling them apart under concurrent turning will not be successful, because the boss will be caught in the primary recess.

15 The invention is especially directed to an inhaler, as mentioned above. Hereby, the first member may be a mouthpiece for the inhaler and the second member a cap. The groove may be arranged in an outer surface of an inner sleeve on the mouthpiece and the boss on an inner surface of an outer sleeve on the cap.

20 There is preferably a primary recess at either side of the notch for providing a "trap" for the boss at turning from either side. The "trapping" effect is enhanced in that each primary recess has a sharp side at the notch for preventing the boss from reaching the notch if a mutual pulling force is exerted on the mouthpiece and the cap. The other end of the primary recess is preferably sloping for facilitating a smooth entrance of the boss in the "trap".

25 Even if the boss is in the position for entering the notch from the groove, so that a pulling apart is possible, a certain resistance may be provided in that the depth of the notch is locally decreased, preferably towards its open end. This resistance may prevent a child from actually pulling the members apart.

30 In order to facilitate a controlled pulling apart of an adult there may be external marks on the mouthpiece and the cap for indicating when the boss is at the notch. It has been shown that such marks do not provide any guidance for a child.

It is preferred that the groove extends around the full periphery of the mouthpiece, so that the two members can be freely rotated. A secondary recess, preferably with

sharp sides, can in such a case be provided substantially opposite the primary recess(es) for providing a secondary "trap" for the boss.

The boss is preferably generally rectangular in a top view but may have a pointed side for facilitating entrance in the notch at assembly of the mouthpiece and the cap.

### The Drawings

The invention will be described in further detail below reference being made to the accompanying drawings, in which:

- Fig 1 is a side view of an inhaler embodying the invention,  
 10 Fig 2 is a section through the inhaler along the line II-II in Fig 1,  
 Fig 3 is a section through the inhaler along the line III-III in Fig 2,  
 Fig 4 is a section to a larger scale through a cap of the inhaler according to Fig 1,  
 Fig 5 is section through the cap along the line V-V in Fig 4,  
 15 Fig 6 is a perspective view of a mouthpiece of the inhaler according to Fig 1,  
 Fig 7 is a top view (to the same scale as Figs 1-3) of the mouthpiece according to Fig 6,  
 Fig 8 is a bottom view of the mouthpiece according to Fig 6, and  
 Fig 9 is a section to a larger scale through a detail of the mouthpiece according to Fig 7.

### Detailed Description of a Preferred Embodiment

An inhaler embodying the invention includes a first member, namely a mouthpiece 1, and a second member, namely a cap 2; the division line between the two members appears as a thicker line in Fig 1. A substance to be inhaled is to be placed in the form of an ampoule (not shown) or the like in the hollow interior of the inhaler. With the exception of the flattened end of the mouthpiece 1 to the left in Fig 1 for comfortable insertion into the mouth of a user, the mouthpiece 1 and the cap 2 both have a circular cross-section, especially in the region where they are connected to each other, and they may thus be turned in relation to each other.

30 The mouthpiece 1 and the cap 2 together form a tube when assembled. Accordingly, the cap 2 has a central, circular opening 3 to the right in Figs 1-4, through which surrounding air is sucked in, whereas the mouthpiece 1 has a flattened or substantially

rectangular opening 4 to the left in Figs 1-3, through which air possibly laden with substance from the ampoule, when fitted in the inhaler, is transferred to the user's mouth.

Internally, the mouthpiece 1 and the cap 2 are provided with integral tubes 5 and 6, respectively, having sharpened ends 5' and 6', respectively, for penetrating seals at the ends of the mentioned, but not shown ampoule, when placed in the interior of the inhaler.

When assembled, the mouthpiece 1 and the cap 2 together form a generally smooth exterior surface in the region for their connection. Also their interior surface is generally smooth in the connection region. This is accomplished in that the cap 2 in its connection region to the left in Figs 4 and 5 has an integral outer sleeve 7 with a smaller wall thickness than the remainder of the cap 2. In the same way, the mouthpiece 1 in its connection region to the left in Figs 7 and 8 has an inner sleeve 8 with a smaller wall thickness than the remainder of the mouthpiece 1. The two sleeves 7 and 8 generally have the same length and fit together for forming the connection shown in Figs 1-3. However, the assembly and disassembly of the two members 1 and 2 can only occur in one mutual position thereof for providing a certain child-resistancy. The invention is primarily concerned with the means for obtaining this child-resistancy; these means will now be described.

The main means for obtaining the desired connection are a boss 9 in the outer sleeve 7 of the cap 2 and a circumferential groove 10 in the inner sleeve 8 of the mouthpiece 1. With the exceptions mentioned below, the width and the depth of the groove 10 are slightly larger than the axial dimension and the height, respectively, of the boss 9, so that the two members 1 and 2 may be rotated in relation to each other with the boss 9 in the groove 10. The groove 10 preferably extends the full turn around the sleeve 8, but it is also possible to have a groove that extends only a shorter distance.

There is only one exit from the groove 10, namely an axial notch 11 in the inner sleeve 8 of the mouthpiece 1. The width of this notch 11 exceeds the circumferential width of the boss 9. The end of the notch 11 opening into the groove 10 may have the same depth as the groove, but the notch depth may decrease towards the end of the notch 11 to the left in Fig 7. This is clearly illustrated in Fig 9, which is an enlarged section through the notch 11 and shows the bottom shape of the notch. By the shallower exit of the notch 11 a certain resistance is provided against the movement of the boss 9 in

the notch 11. In other words, a certain force is needed for pulling the mouthpiece 1 and the cap 2 apart, even if the rotational position with the boss 9 in front of the notch 11 has been found.

Assistance in this respect is provided in that the mouthpiece 1 and the cap 2  
5 each have an external mark 12 (Fig 7) and 13 (Fig 5), respectively, which marks are to be put in front of each other for placing the boss 9 at the notch 11. It has been shown that this indication is not properly understood by small children.

At each side of the notch 11 there is a primary recess 14 in the forward edge (to  
10 the left in Fig 7) of the groove 10. Each recess 14 has a sloping side facing away from the notch 11 and a sharp side at the notch with the result that if the mouthpiece 1 and the cap 2 when connected are mutually rotated while also pulled apart, the boss 9 will enter the recess 14 along the sloping side but be stopped against the sharp side, so that the boss cannot find its way out through the notch 11.

At the side of the mouthpiece 1 generally opposite the notch 11 the groove 10  
15 may be provided with a secondary recess 15 providing a further locking of the two parts mouthpiece 1 and cap 2 if they are rotated and pulled apart in an attempt to separate the two members from each other.

The side of the groove 10 opposite the notch 11 and the recesses 14 and 15 is  
20 smooth, which means that the boss 9 can slide freely against this side when the mouthpiece 1 and the cap 2 are mutually rotated but not pulled apart.

As appears from Figs 4 and 5, the boss 9 may have bevelled edges and a slightly pointed end for facilitating entry into the notch 11 at assembly.

An important feature of the invention is the provision of the "trap" constituted  
25 by the primary recesses 14, and it has to be pointed out that several practical alternatives to the recesses shown and described are possible within the scope of the claims.

**CLAIMS**

1. A pharmaceutical container or inhaler device for preventing an easy pulling  
5 apart of two connected, mutually rotatable members (1, 2) having circular cross sections  
where the members are connected.

characterized in

that a first member (1) towards its end intended for connection with a second  
member (2) is provided with a groove (10) extending in a circumferential direction,

10 that the second member (2) towards its end intended for connection with the first  
member (1) is provided with at least one boss (9) for engagement with the groove (10),

that the first member is provided with at least one axial notch (11) from the groove  
(10) to the end of the first member, and

15 that the groove (10) in the vicinity of each notch (11) is provided with at least one  
primary recess (14) in the side in which the notch opens, and

that the first member (1) and the second member (2) are rotatable in relation to one  
another in a clock-wise direction as well as in an anti-clock-wise direction, thus preventing  
an easy pulling apart of said two members (1, 2)

20 2. A device according to claim 1, characterized in that the bosses and notches  
are distributed with different pitch, when there is provided more than one boss and notch.

3. A device according to claim 1, characterized in that there is provided one  
boss (9) and one notch (11).

25 4. A device according to claim 3, the first member being a mouthpiece (1), the  
second member being a cap (2) thereof, the groove (10) being arranged in an outer surface  
of an inner sleeve (8) on the mouthpiece (1) and the boss (9) being arranged on an inner  
surface of an outer sleeve (7) on the cap (2), characterized in that there is the primary recess  
30 (14) is at either side of the notch (11), each recess having a sharp side at the notch for  
preventing the boss (9) from reaching the notch if a mutual pulling force is exerted on the  
mouthpiece (1) and the cap (2).

5. A device according to claim 4, characterized in that the other end of each primary recess (14) is sloping.

5 6. A device according to claim 4, characterized in that the depth of the notch (11) is locally decreased for increasing the force needed to rotate the first member (1) and the second member (2) in relation to one another.

10 7. A device according to any of claims 4-6, characterized in that there are external marks (12, 13) on the mouthpiece (1) and the cap (2) for indicating when the boss (9) and the notch (11) are engaged.

15 8. A device according to any one of claims 4-7, characterized in that the groove (10) extends around the full periphery of the mouthpiece (1) and is provided with a secondary recess (15) with sharp sides substantially opposite at least one primary recess (14).

20 9. A device according to any one of claims 4-8, characterized in that the boss (9) is generally rectangular in a top view but has a pointed side for facilitating entrance in the notch (11) at assembly of the mouthpiece (1) and the cap (2).

1/2

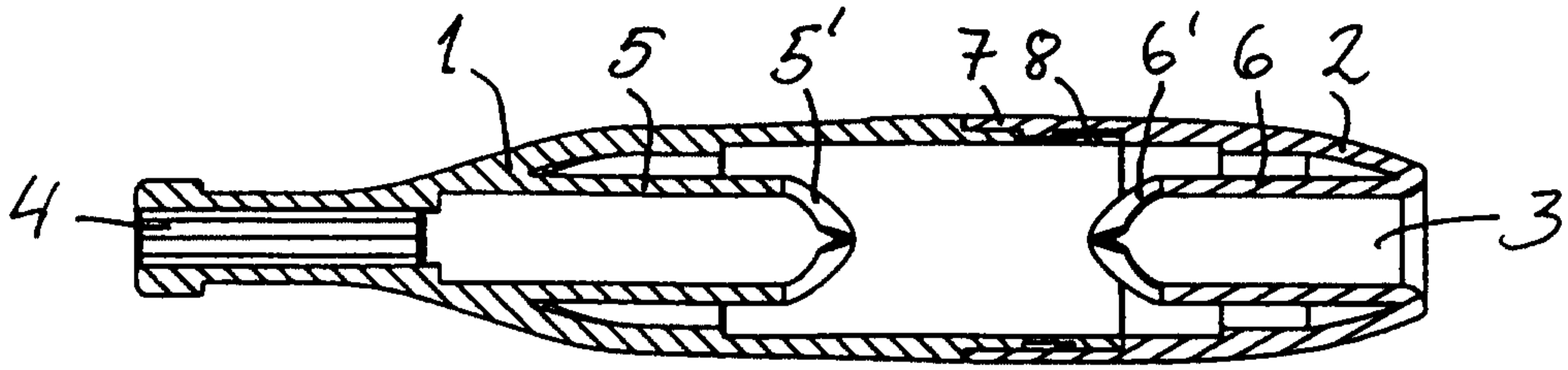

Fig. 3

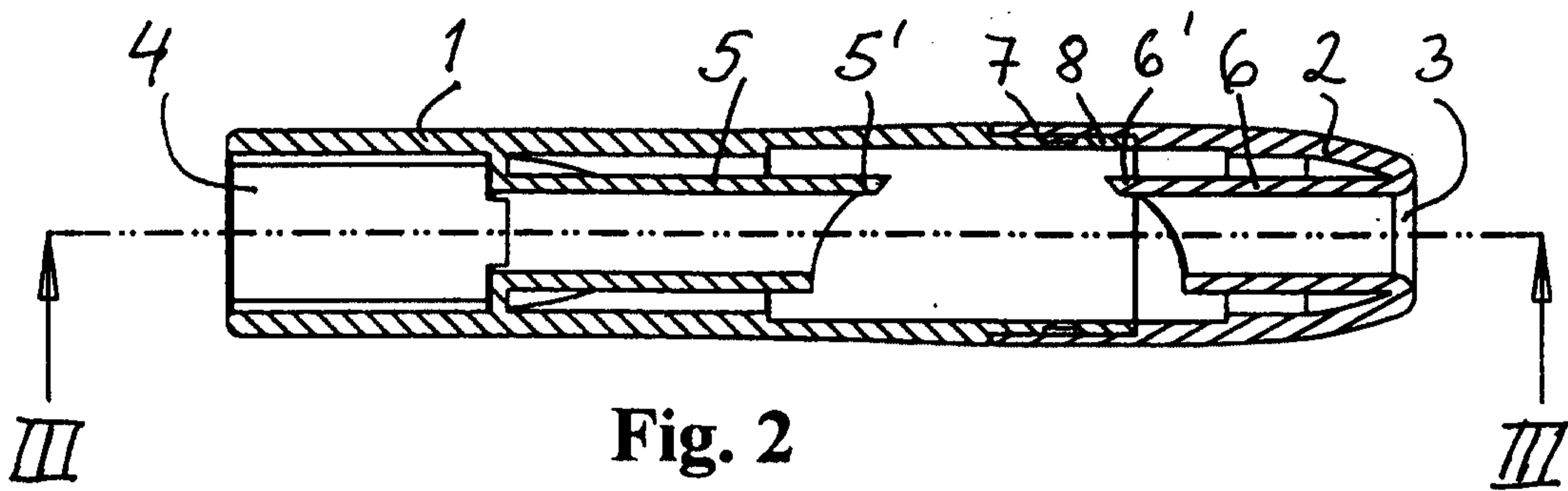

Fig. 2

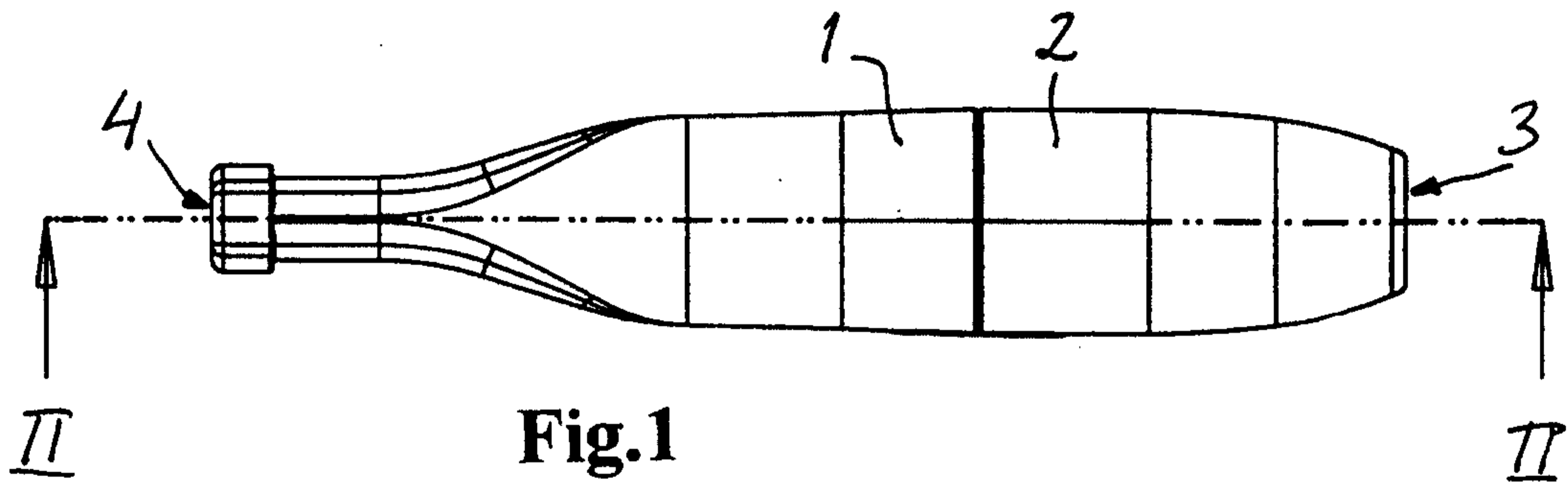

Fig. 1

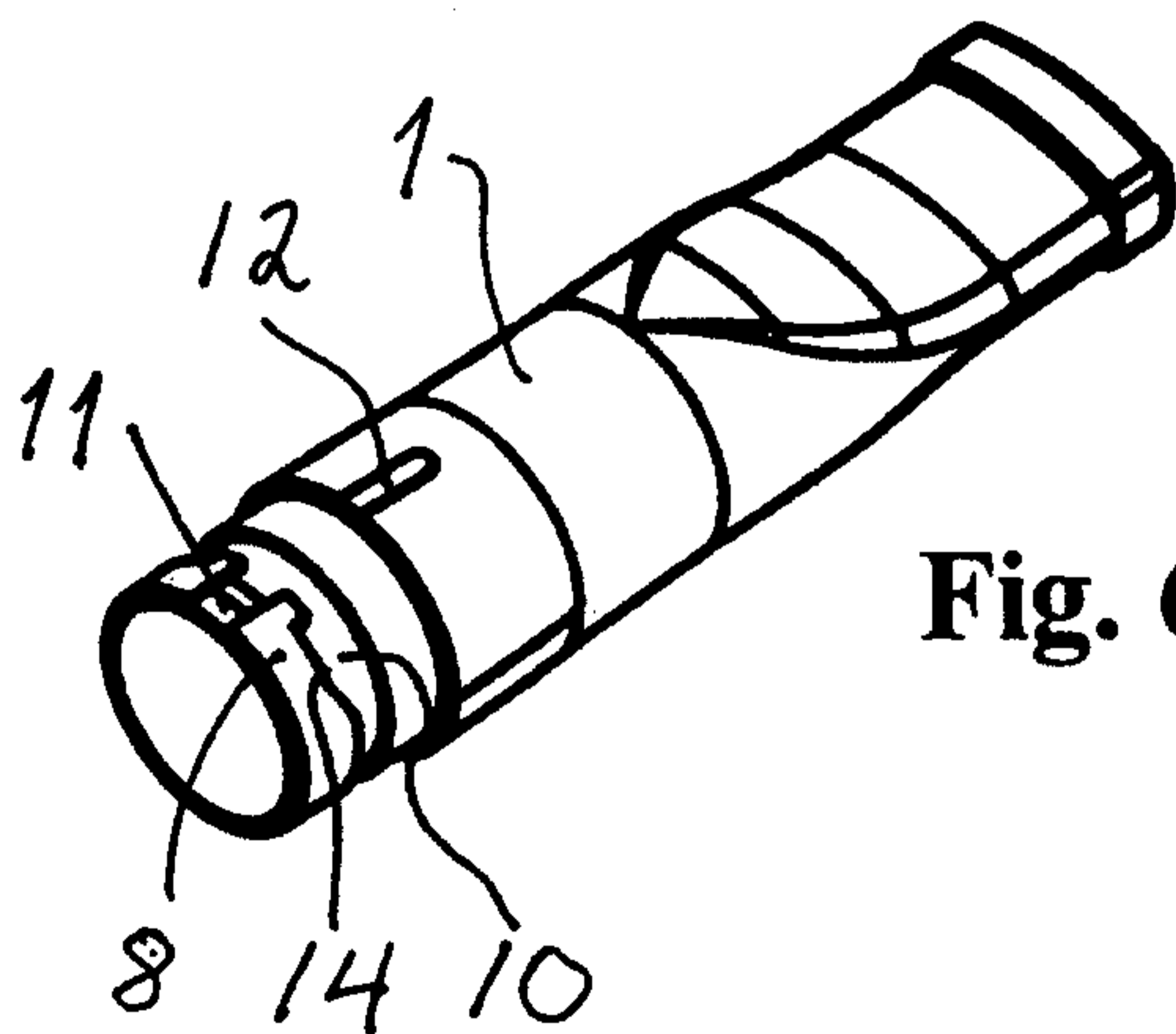

Fig. 6

2/2

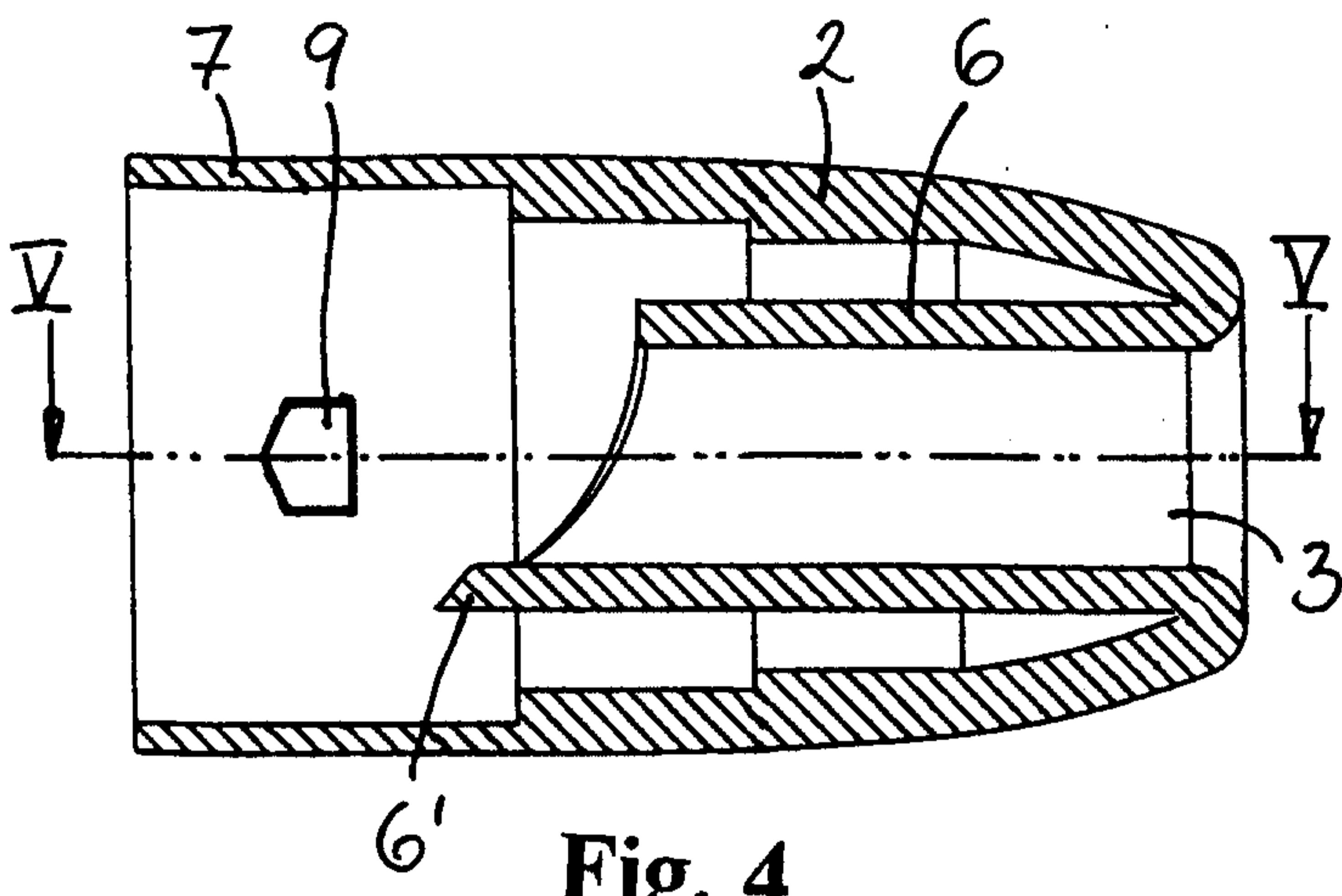

Fig. 4

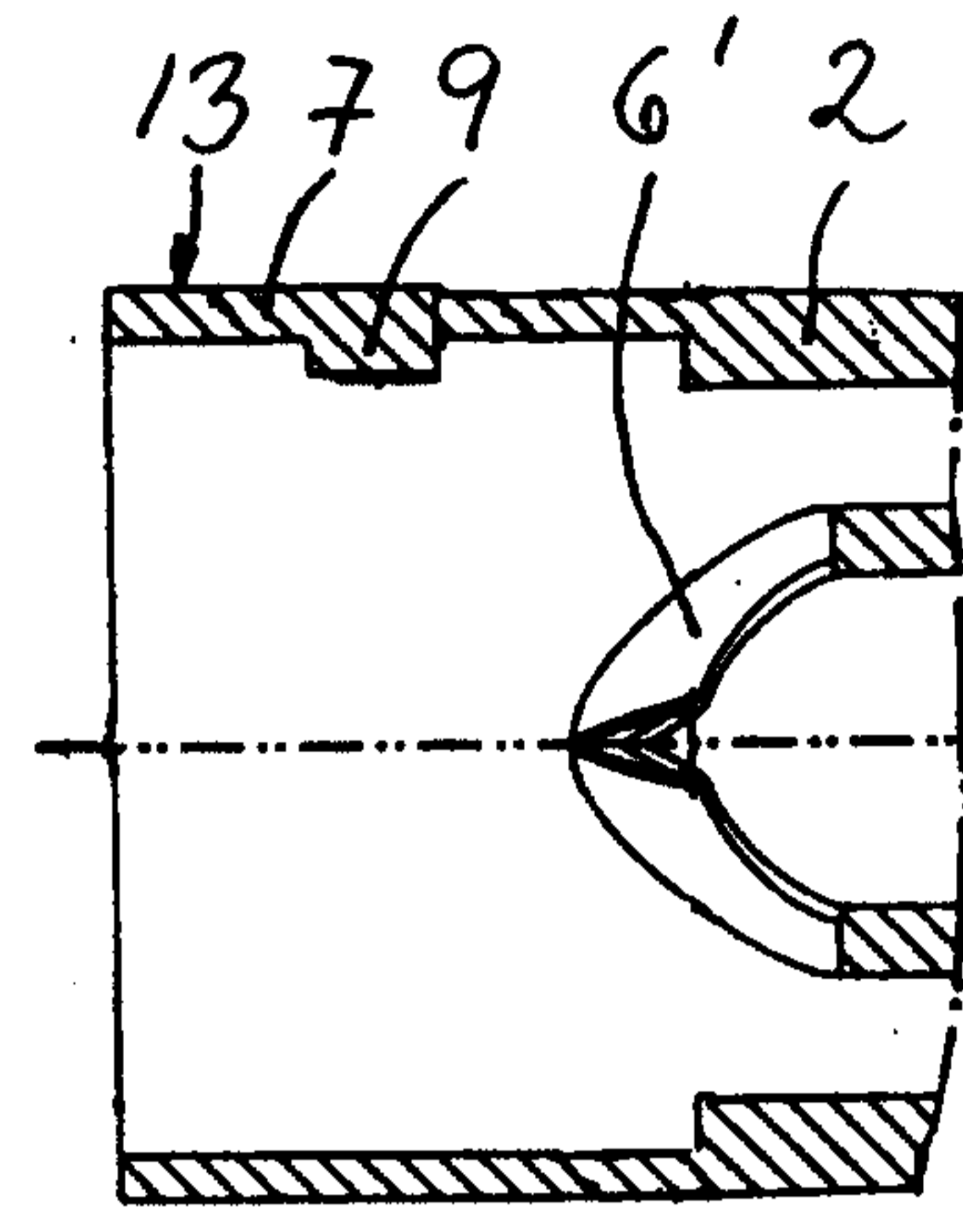

Fig. 5

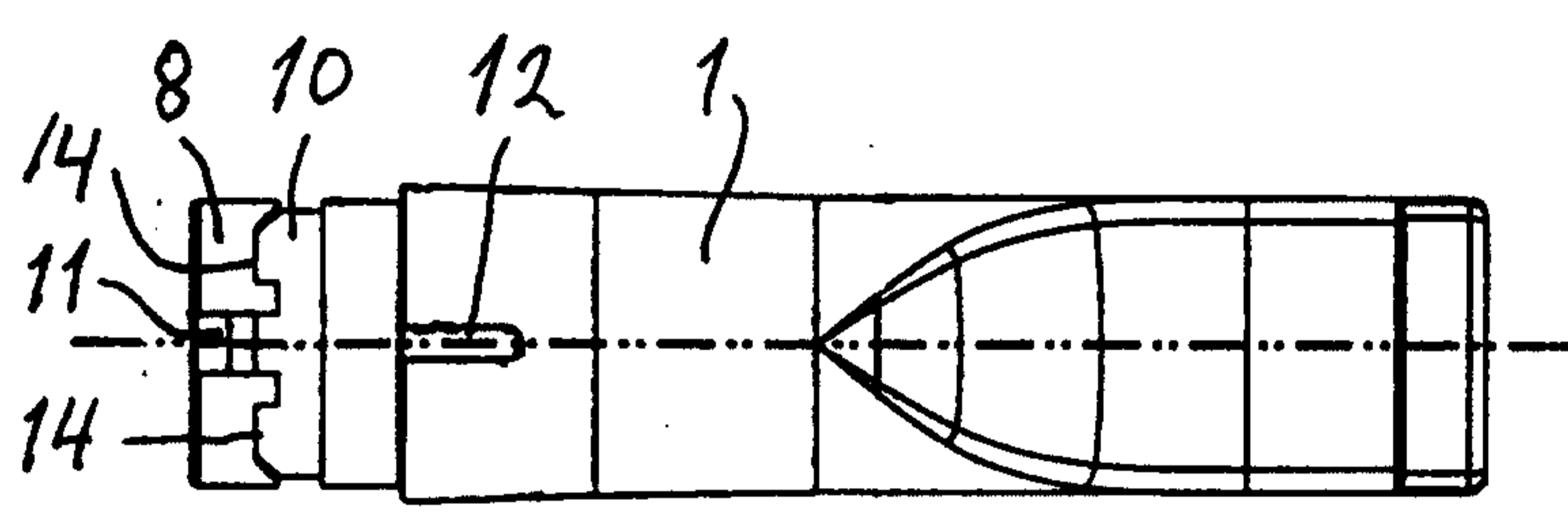

Fig. 7

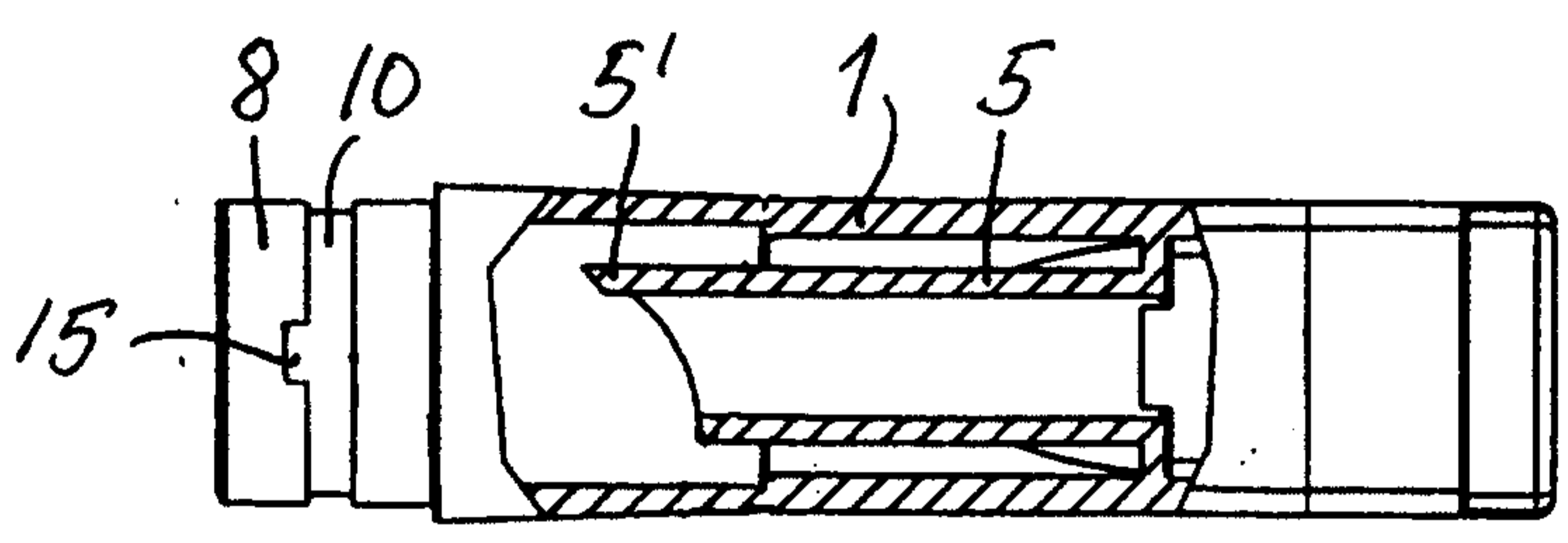

Fig. 8

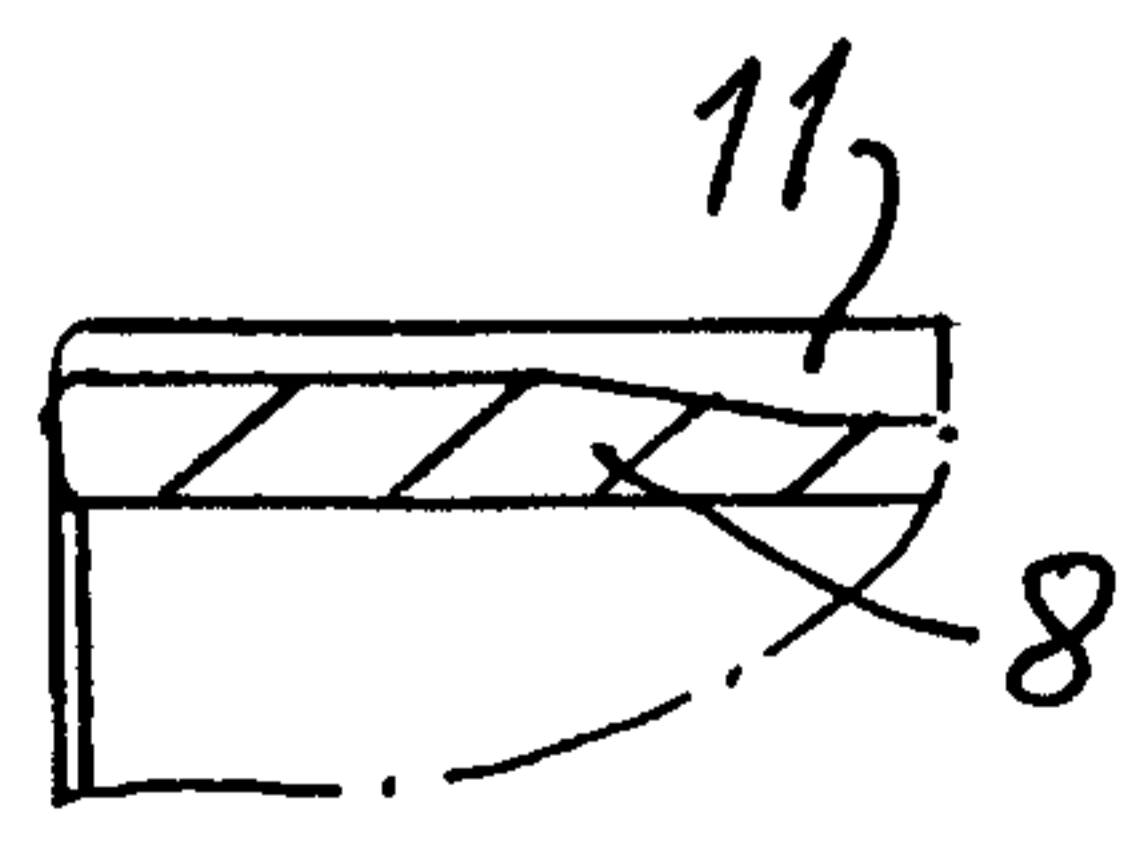

Fig. 9

