

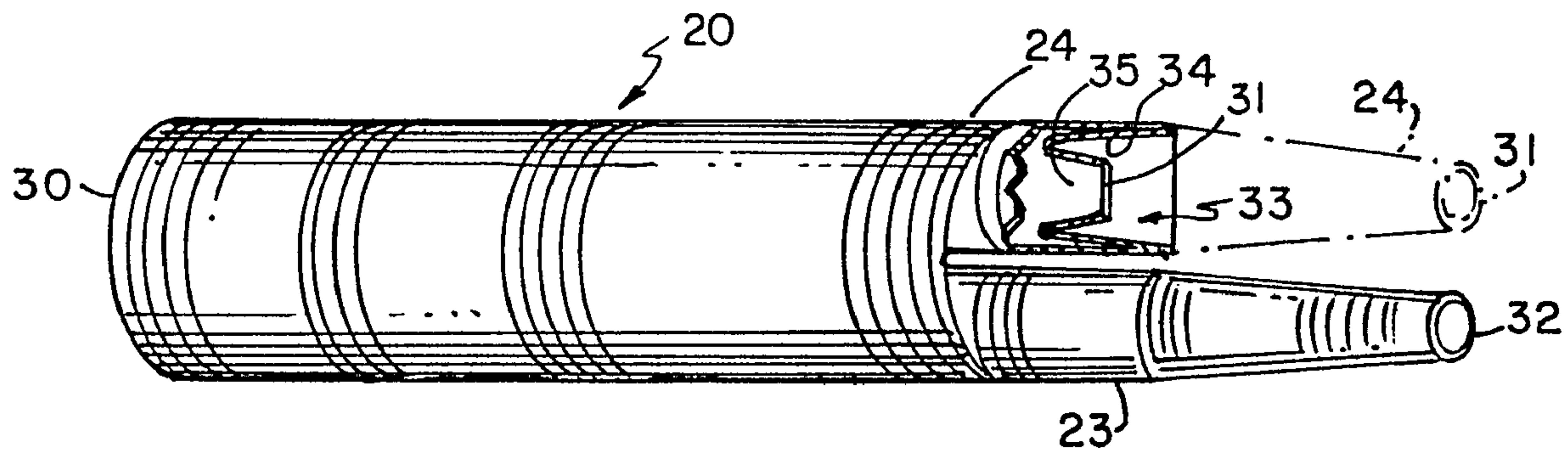

(86) Date de dépôt PCT/PCT Filing Date: 1996/01/29
 (87) Date publication PCT/PCT Publication Date: 1996/08/08
 (45) Date de délivrance/Issue Date: 2007/03/20
 (85) Entrée phase nationale/National Entry: 1997/07/03
 (86) N° demande PCT/PCT Application No.: US 1996/000966
 (87) N° publication PCT/PCT Publication No.: 1996/023455
 (30) Priorité/Priority: 1995/01/31 (US08/381,099)

(51) Cl.Int./Int.Cl. *A61F 2/06* (2006.01)
 (72) Inventeur/Inventor:
 RAVENSCROFT, ADRIAN C., US
 (73) Propriétaire/Owner:
 BOSTON SCIENTIFIC CORPORATION, US
 (74) Agent: FETHERSTONHAUGH & CO.

(54) Titre : GREFFE AORTIQUE ENDOVASCULAIRE
 (54) Title: ENDOVASCULAR AORTIC GRAFT



(57) **Abrégé/Abstract:**

An intraluminal prosthesis for intraluminal repair of body conduits, especially aortic aneurysms, is disclosed. The prosthesis includes a generally tubular, flexible graft (20) having a proximal open end (30) and at least one distal open end (31) terminating in a hem (33). A stent (21) can be disposed within the proximal open end (30) and is adapted to be attached to the body conduit (1). The hem (33) is inverted within the graft so that it is disposed as a cuff (34) within the graft. The hem (33) is arranged so that upon withdrawing the distal open end (31) from inside the cuff (34), the cuff will unfold and follow the distal open end to expose it to receive another stent for attachment to the body conduit (12) for intraluminal implantation of the graft. Preferably the hem is folded a second time within the cuff to form a second cuff (35) within the graft. The stents are preferably formed of a plexus of wires adapted to expand from a first narrow diameter to a second diameter to engage the body conduit. Also disclosed is a method of intraluminal implantation of the graft.

ENDOASCULAR AORTIC GRAFT

5 Field of the Invention

The present invention relates to an interluminal prosthesis for intraluminal repair of body conduits. More specifically, the present invention relates to intraluminal repair of aneurysms using an arterial interluminal prosthesis. Furthermore, the present invention relates to a method of implanting the interluminal prosthesis in an artery. The invention especially relates to an arterial interluminal prosthesis having a tubular form where one end of the tube is connected to the thoracic aorta and the other end is bifurcated to form two tubular passageways and each passageway is connectable to each of the iliac arteries.

Description of the Prior Art

Interluminal devices for repairing body conduits are well known to the art. Such devices include tubular flexible grafts that are implanted by the use of stents. Stents are a means of attachment of intravascular prostheses.

With special reference to abdominal aortic aneurysms, such aneurysms occur because of an abnormal dilation of the wall of the aorta within the abdomen. Surgical procedures involving the abdominal wall are major undertakings with high associated risk together with considerable mortality. The replacement of the aorta with surgical procedures involves replacing the diseased portion of the vessel with a prosthetic device which is typically formed of a synthetic tube or graft, usually fabricated of Dacron®, Teflon®, or other suitable material. In the surgical procedure, the aorta is exposed through an abdominal incision. The aorta is closed both above and below the aneurysm so that the aneurysm can be opened and any thrombus and arteriosclerotic debris can be removed. A graft of approximately the size of a normal aorta and is sutured in place to replace the aneurysm. Blood flow is then reestablished through the graft.

Surgery according to the prior art required an extended recovery period together with difficulties in suturing the graft to the aorta.

5 In the European patent application to Barone et al., number 0,461,791 A1, a method is disclosed for repairing an abdominal aortic aneurysm which includes a tubular graft that is intraluminally delivered through the iliac artery and secured to the aorta by the expansion and deformation of a stent. In the application, a tube is disclosed which has
10 a single end that is bifurcated to two other ends each of which is attached to one of the iliac arteries. Such disposition of the graft can provide a reduction in the trauma of the surgery because the graft is delivered to the site intraluminally. While one connection to an iliac artery is
15 reasonably easy to accomplish, rather complicated techniques are required to move the other leg of the graft to the other iliac artery and connect it thereto.

A patent to Parodi et al., 5,219,355, discloses a balloon device for implanting an aortic interluminal prosthesis to repair aneurysms. In the patent, a graft prosthesis is disposed upon a catheter having two balloons mounted
20 thereon. The prosthesis is mounted on the catheter and stents are mounted upon the balloons. The assembly of the graft, the two balloons and the stents are introduced into
25 the aneurysm by catheterization. The balloons are inflated to implant the prosthesis within the aneurysm and affix the stents against the artery walls, thereby to repair the aneurysm. The balloons are deflated and the catheter is
30 withdrawn.

Summary of the Invention

According to the present invention I have discovered an interluminal prosthesis especially useful for intraluminal repair of aneurysms. The prosthesis includes a generally
35 tubular flexible graft of conventional prosthetic graft material having a proximal open end and at least one leg

with a distal open end and preferably two legs with two distal open ends. Preferably, a first stent is disposed within and attached to the proximal open end. The first stent emerges from the proximal open end and is adapted to be attached to the aorta intraluminally. A hem terminating in the distal open end of the graft is inverted within the leg. The hem is arranged as a cuff within the leg. A second stent having a proximal and a distal end can be attached to the interior of the distal end of the cuff so upon withdrawing the second stent from the cuff, the cuff will unfold and follow the stent for implantation of the graft. In a preferred embodiment the graft is bifurcated at one end to form two legs, each terminating in distal open ends. Each leg is attached to one of the iliac arteries. In the preferred embodiment also, the hem is inverted a second time to form a second cuff within the first cuff. The stent extends outwardly from the distal open end of the second cuff. Many of the stents are devices which are deformed by increasing the diameter until they engage a wall of a body conduit and are anchored thereto. Alternatively they may be integrally knitted into the graft or they may be polymeric impregnations of the graft which harden upon heating to enable the hardened impregnation to engage the body conduit.

To dispose the graft within the aorta a conventional guidewire is threaded through the iliac artery into the aorta using conventional techniques. A delivery catheter is then threaded over the guidewire until it reaches the desired location within the aorta. A graft having at least two open ends is disposed on the delivery catheter. Each open end of the graft can have a stent disposed therein. The portion of the graft that is adapted to be attached to the aorta has the stent extending outwardly from its open end so that the graft may be attached to the aorta. In the case of a bifurcated graft in which two legs of the graft are to be attached to the two iliac arteries branching from

the aorta, one of the legs can have a stent extending outwardly from its open end. The other leg of the graft is disposed inside the graft leg in the form of a cuff which is inverted into itself at the open end. A stent
5 can be attached to the cuff. A balloon catheter is disposed near the end of the inverted leg. The inside of the inverted leg is engaged by the balloon and is withdrawn through the other iliac artery. When
appropriately positioned within the iliac artery, the
10 stent is expanded to engage the artery and set it. The balloon and then the guidewire is then withdrawn from the artery and the procedure is completed.

According to further broad aspect of the present
15 invention, there is provided an intraluminal prosthesis for intraluminal repair of a proximal location within a body lumen from a distal location outside the body lumen. The prosthesis comprises a generally tubular, flexible graft having a proximal portion with a proximal open end
20 and at least one leg having a distal open end and a first distal portion adapted to be inverted proximally and radially inwardly into an inverted configuration. At least one stent is disposed within and attached to the graft for anchoring the graft within the body lumen.

25

According to a still further broad aspect of the present invention, there is provided an intraluminal device comprising a graft having a first open end and at least one second open end. The second open end is
30 adapted to be inverted within the graft in an inverted configuration to form an inverted end portion. The inverted end portion is adapted to be withdrawn from the

inverted configuration after the device has been inserted within a body lumen.

Brief Description of the Drawing

5 Figure 1 is a side elevational view partially in cross section of one embodiment of a bifurcated aortic implant adapted to be disposed within an aneurysm formed in the aorta and connected to each iliac artery.

10 Figure 2 is a side elevational view, partially in cross-section, illustrating another embodiment of an aortic implant.

Figures 3 to 10 are a series of views showing a stage-wise progression for performing a procedure to implant a graft within an aortic aneurysm.

15

Description of the Preferred Embodiments

Referring now to Figure 1, an arterial interluminal prosthesis 20 for repairing aneurysms is shown, partially in cross section. The graft or prosthesis, when
20 implanted, has a generally circular cross-sectional configuration. It may be made from a variety of materials provided they have requisite strength characteristics to be utilized as an aortic graft as well as have requisite compatibility with the human body so
25 that the implant material will not be rejected. Examples of such material are Dacron® and other polyester materials, Teflon® (polytetrafluoroethylene), Teflon® coated with Dacron® material and porous polyethylene urethane. The

material can be knitted or woven. The graft can also be made of extruded polymeric materials, all of which are well known to the art as graft materials.

5 The graft 20 has a proximal open end 30 and two distal open ends 31 and 32. The distal open ends are disposed on legs 23 and 24 which bifurcate from the graft 20. Each leg preferably is the same length initially, although with some procedures it may be preferable to make the legs axially stretchable to provide for adjustments in length which may be needed during implantation. The distal open end 31 of the leg 24 is at the end of a hem 33 which extends from the edge of the inward fold of the leg 24 to the distal open end 31. The length of the leg 24 is not critical so long as it is adequate to be grasped by a catheter and intra-
10 luminally drawn into the iliac artery. A first inversion of the hem 33 forms a first cuff 34. In the preferred embodiment the hem 33 is inverted a second time to form a second cuff 35 which opens away from the proximal open end 30. Preferably the leg 24 (or both the legs 24 and 23) are
15 truncated or tapered with the narrowest diameter being at the distal open ends to enable the hem to be more easily folded within the leg and form a cuff(s).

20 A stent (not shown) is disposed within the distal open end 31 of graft 20. The stent emerges from the distal open end 31 to enable it to be attached to the iliac artery. Another stent (not shown) is disposed within the leg 23 at its distal open end 32. A third stent (not shown) is disposed in the proximal open end 30 to attach to the thoracic artery.

25 Several types of stents can be used. Common stents are plexuses of wires that can be expanded with internal force, such as provided by a balloon, to engage an artery wall. Other stents having applicability include polymeric expandable structural members and polymeric compositions at the
30 end of the leg which harden when expanded and activated by heat. A stent can alternatively be constructed as a lining
35

within a graft and extending from one end of the graft to the other to provide for both fastening of the graft to an artery and its structural stability.

5 Referring now to Figure 2, a graft 40 is shown partial-ly in cross-section. In this embodiment the graft 40 is tubular-shaped and does not have two legs as is disclosed in the previous embodiment. The graft 40 has a proximal open end 41 in which a stent 42 is disposed. The graft 40 fur-
10 ther has a distal open end 43 disposed at the end of a hem 44. The hem 44 is inverted within the graft 40 to form a first cuff 45 and in the preferred embodiment is inverted a second time to form a second cuff 46. The second cuff 46 is especially beneficial because it enables the hem 33 to be withdrawn from the leg 24 easily. When a stent is in-
15 serted within the distal open end 43 it can engage the distal open end 43 to draw the hem 44 outwardly and cause the cuff 45 to unfold and then cause the cuff 46 to unfold also. In this embodiment, as with the embodiment illustrat-
20 ed in Figure 1, the graft 40 can be truncated or tapered toward the distal open end to provide for easy inversion of the hem 44 into the graft 40. In the preferred embodiment, the hem is truncated into two progressively narrower diame-
ters or tapered with the distal open end 43 having the smallest diameter.

25 Figures 3 to 10 show a portion of the abdominal aortic artery to be treated connected in its upper part with tho-racic artery 1 from which renal arteries 2 depart. The abdominal aorta presents an aneurysm 5 which goes almost to the thoracic aorta 1. The thoracic aorta 1 bifurcates at 13
30 into two iliac arteries 11 and 12.

A conventional guidewire 3 is conventionally threaded into the right iliac artery 11 into the abdominal aorta through the aneurysm 5 until it reaches the thoracic aor-
ta 1, as shown in Figure 3.

35 Referring to Figure 4, implantation of the graft illus-trated in Figure 1 is shown. A delivery catheter covered by

a sleeve 14 is slipped over the guidewire 10 until its distal end is located above the aneurysm 5. The delivery catheter includes a hollow center shaft (not shown) covered by the graft as shown in Figure 1, the graft being tightly wrapped around the delivery catheter, as is conventional. The assembly of the delivery catheter would be the same for the embodiment shown in Figure 2. If stents are delivered with the graft, they are collapsed, as is conventional also. The graft and stents are covered by the sleeve 14, as is conventional also. After delivery of the graft, it is positioned so that its proximal open end 30 is above the aneurysm 5. The sleeve 14 is withdrawn through the iliac artery 11 to leave the graft and stent uncovered. In the embodiment shown, especially in Figure 5, as the sleeve 14 is withdrawn through the artery 11, stent 21 will automatically enlarge to engage the aorta wall 1 and as the sleeve 14 is further withdrawn, stent 22 enlarges and engages the interior of artery 11 to anchor the graft 20 in place.

Referring to Figure 5, the graft 20 is shown expanded and deployed between the thoracic artery 1 and the right iliac artery 11. Stent 21 has enlarged (or been enlarged) to engage the interior wall of the thoracic artery 1 and hold the graft 20 in place. The second stent 22 is shown engaging the right iliac artery 11 to hold left leg 23 in place. With the delivery mechanism illustrated in Figure 4, the graft 20 has been delivered with the stents 21 and 22 in place within graft 20. The right leg 24 of the graft has been inverted within the graft 20 during the delivery. When the stents are deployed, the right leg 24 will remain inside of the graft 20. Following deployment of the graft 20, the guidewire 10 and center shaft 25 (upon which the graft 20 was mounted when the device was deployed within the artery) is withdrawn through the right iliac artery 11.

As shown in Figure 6, a catheter 26 is inserted into the left iliac artery 12 and directed into right leg 24 that

is inverted in the graft 20. One of the more suitable means for engaging the leg 24 is a catheter carrying a balloon 37 with a stent mounted upon it (if the leg 24 was not implanted with a stent already in place). Enlargement of the balloon 37 will enlarge the stent sufficiently to enable the stent to grasp the inside of the leg 24 and withdraw it through itself. Alternatively, a catheter with a stent mounted on it can be inserted into the leg 24 after it has been drawn into the left iliac artery 12. Another mechanism to withdraw the leg is to insert a hook which will engage the inverted leg. The stent can be enlarged as described above.

As shown in Figure 7, the catheter 26 that was inserted into the left iliac artery 12 to engage the distal open end of the leg 24 is being withdrawn from within the graft 20 by drawing catheter 26 through the artery 12. The distal open end and the inverted leg 24 will follow it. When the inverted leg 24 is fully withdrawn, one of several techniques can be used to implant the stent. In one technique, the stent is deployed upon a balloon catheter and inflation of the balloon (when the stent is in a correct position in the left iliac artery 12) will cause the stent to be seated. Another approach involves a stent disposed within the leg 24 while it is inverted within the graft 20. In this approach, when the leg 24 is drawn from the graft 20 the stent will emerge and enlarge automatically as the leg 24 is drawn out. Moreover the stent can be a polymeric impregnation of the leg, as mentioned above. Expansion of the leg 24 against the artery and heating will stiffen the leg 24 to implant the prosthesis.

In Figure 8 the balloon catheter is shown enlarging the stent to it in the iliac artery 12. Figure 9 shows the balloon catheter being moved from the position within the stent 28 just immediately prior to withdrawal of the catheter 26 from the iliac artery. The balloon can be deflated to allow for easy withdrawal of the catheter from the stent

and through the artery.

Figure 10 shows the graft 20 implanted between the two iliac arteries 11 and 12 and the thoracic aorta 1. A stent 22 anchors the left leg 23 of the graft 20 to the right iliac artery 11 and a stent 28 anchors the right leg 24 to the left iliac artery 12. The aneurysm 5 surrounds the graft but does not receive blood into it. Drainage of the aneurysm can be accomplished percutaneously or otherwise, as is conventional.

The graft depicted in Figure 2 of the drawings having only one distal open end can be deployed and implanted similarly as the embodiment shown in Figure 1, except the procedure is less complicated in that the procedure requires entering through only one of the iliac arteries.

While it is apparent that changes and modifications can be made within the spirit and scope of the present invention, it is my intention, however, only to be limited by the appended claims.

CLAIMS

1. An intraluminal prosthesis for intraluminal repair of a proximal location within a body lumen from a distal location outside said body lumen, said prosthesis comprising:

a generally tubular, flexible graft having a proximal portion with a proximal open end and at least one leg having a distal open end and a first distal portion adapted to be inverted proximally and radially inwardly into an inverted configuration; and

at least one stent disposed within and attached to said graft for anchoring said graft within said body lumen.

2. The prosthesis of claim 1, wherein said at least one leg has a second distal portion adapted to be inverted distally and radially inwardly from said first distal portion.

3. The prosthesis of claim 1, wherein said at least one leg is axially stretchable.

4. The prosthesis of claim 1, wherein said at least one leg is tapered along the length toward the distal open end.

5. The prosthesis of claim 1, wherein the proximal portion has a first diameter and the first distal portion has a second diameter smaller than the first diameter.

6. The prosthesis of claim 5, wherein said first distal portion comprises a diameter at its distal end equal to said second diameter, and an axial portion of said leg proximal said first distal portion comprises a diameter

larger than said second diameter and smaller than said first diameter.

7. The prosthesis of claim 6, wherein the axial portion of said leg comprises a tapered diameter from said first diameter to said second diameter.

8. The prosthesis of claim 5, wherein:
said at least one leg has a second distal portion adapted to be inverted distally from said first distal portion, said second distal portion having a diameter equal to said second diameter and first distal portion having a third diameter greater than said second diameter; and

said at least one leg has an axial portion proximal said first distal portion having a fourth diameter greater than said third diameter and smaller than said first diameter.

9. The prosthesis of claim 8, wherein the axial portion of said leg proximal said first distal portion comprises a tapered diameter from said first diameter to said third diameter.

10. The prosthesis of claim 1, wherein said at least one leg comprises two legs.

11. The prosthesis of claim 10, wherein only one of said two legs comprises a first distal portion adapted to be inverted.

12. The prosthesis of claim 1, wherein said at least one stent comprises:

a first stent disposed within and attached to said first distal portion of said at least one leg; and

a second stent disposed within and attached to said proximal portion of said graft.

13. The prosthesis of claim 12, wherein said first stent protrudes distally from said distal open end and said second stent protrudes proximally from said proximal open end.

14. The prosthesis of claim 12, wherein said at least one leg comprises two legs, said first stent is disposed in one of said legs, and said at least one stent further comprises a third stent disposed in and attached to another of said legs.

15. The prosthesis of claim 1, wherein said at least one stent comprises a single, integral stent extending from said proximal open end to said distal open end of said graft.

16. The prosthesis of claim 15, wherein said stent protrudes proximally from said proximal open end and distally from said distal open end of said graft.

17. The prosthesis of claim 1, wherein said at least one stent is expandable from a first narrow diameter to a second wider diameter and comprises a plexus of wires adapted for expansion by an internal force.

18. The prosthesis of claim 1, wherein said at least one stent is expandable from a first narrow diameter to a second wider diameter and comprises a self-expandable plexus of wires.

19. The prosthesis of claim 1, wherein said at least one stent is expandable from a first narrow diameter

to a second wider diameter and comprises a plurality of polymeric expandable structural members.

20. The prosthesis of claim 1 further comprising a polymeric composition in at least said first distal portion, said polymeric composition adapted to harden when expanded and activated by heat.

21. The prosthesis of claim 1, wherein the prosthesis is adapted for repairing an aortic aneurysm in an aorta which branches into a first iliac artery and a second iliac artery, said graft comprising a first leg having a first distal open end and a second leg having a second distal open end, in which said at least one stent comprises a first stent disposed within said proximal open end and protruding proximally therefrom for deployment in the aorta, and a second stent disposed within and attached to the first distal open end and protruding distally therefrom for deployment in the first iliac artery; and in which the second leg comprises the first distal portion, the first distal portion adapted to be withdrawn for deployment in the second iliac artery.

22. The prosthesis of claim 1, wherein the prosthesis is adapted to be introduced into a body lumen with the first distal portion in the inverted configuration, the first distal portion adapted to be withdrawn from the inverted configuration after the prosthesis is within the body lumen.

23. An intraluminal device comprising a graft having a first open end and at least one second open end, the second open end inverted within the graft in an inverted configuration to form an inverted end portion, the inverted

end portion capable of being withdrawn from the inverted configuration after the device has been inserted within a body lumen.

24. The device of claim 23 further comprising a hook capable of being inserted into the inverted end portion and pulled to withdraw the inverted end portion from the inverted configuration.

25. The device of claim 23 further comprising an inflatable balloon capable of being inserted into and sized to engage the inverted end portion to withdraw the inverted end portion from the inverted configuration.

26. The device of claim 23 further comprising a stent mounted on an inflatable balloon capable of being inserted into and sized to engage the inverted end portion to withdraw the inverted end portion from the inverted configuration.

27. The device of claim 23, wherein the device comprises a plurality of second open ends, each of which is inverted within the graft to form a plurality of inverted end portions, each capable of being withdrawn from the inverted configuration after insertion of the device within the body lumen.

28. The device of claim 27, wherein the plurality of inverted end portions comprises a first distal leg portion and a second distal leg portion, the first distal leg portion positioned to be withdrawn into a first iliac artery and the second distal leg portion positioned to be withdrawn into a second iliac artery.

29. The device of claim 23, wherein the graft comprises a bifurcated graft having a proximal portion, a first distal leg portion, and a second distal leg portion, the second distal leg portion comprising the inverted end portion, the proximal portion positioned to be placed in an aorta and the first distal leg portion positioned to be placed in a first iliac artery prior to the second distal leg portion being withdrawn from the inverted configuration into a second iliac artery.

30. The device of claim 23, wherein the device comprises a first stent disposed within and attached to the first open end.

31. The device of claim 30, wherein the device further comprises a second stent disposed within and attached to the second open end.

32. The device of claim 31, wherein the second stent protrudes from the second open end and is adapted to be engaged for withdrawing the inverted end portion.

33. The device of claim 23 wherein said graft comprises a polymeric composition in at least said inverted end portion, said polymeric composition adapted to harden when expanded and activated by heat to anchor said second open end within said body lumen after the inverted end portion is withdrawn from the inverted configuration.

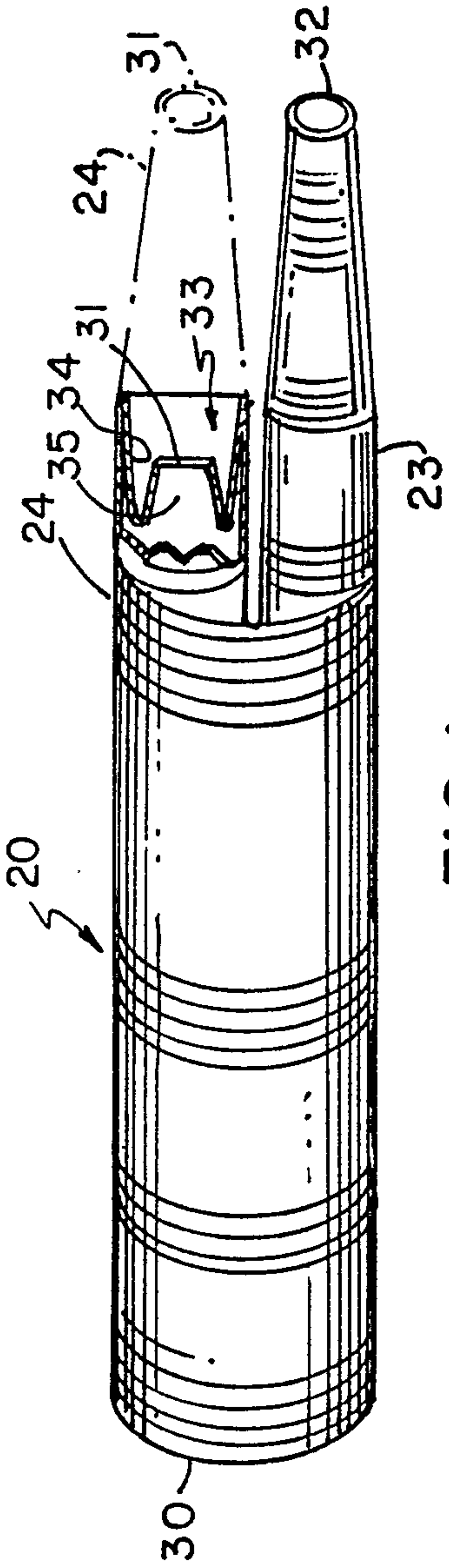

FIG. 1

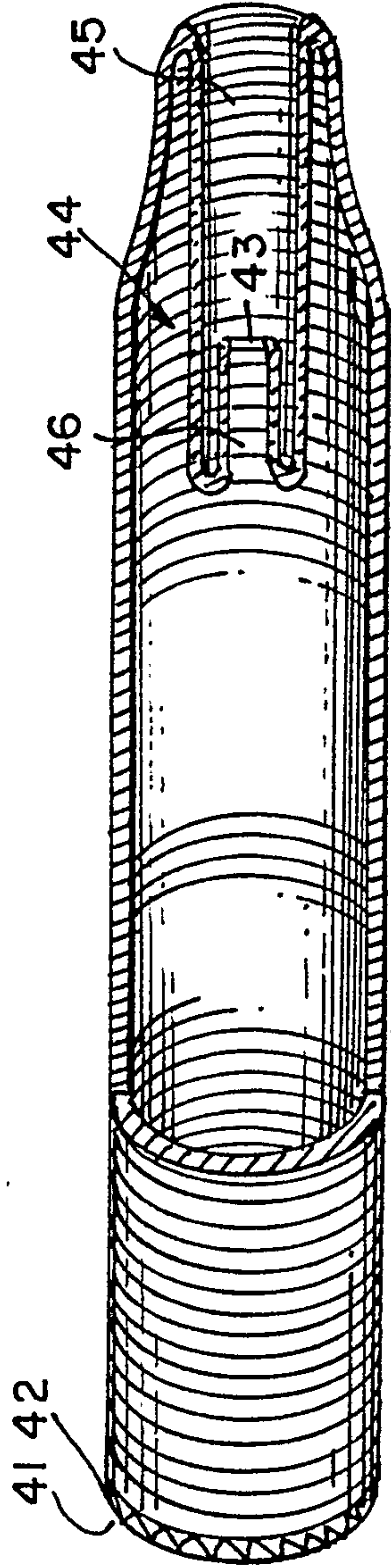

FIG. 2

