

Sept. 17, 1935.

F. LUTZ

2,014,687

SEWING MACHINE

Filed Aug. 21, 1933

2 Sheets-Sheet 1

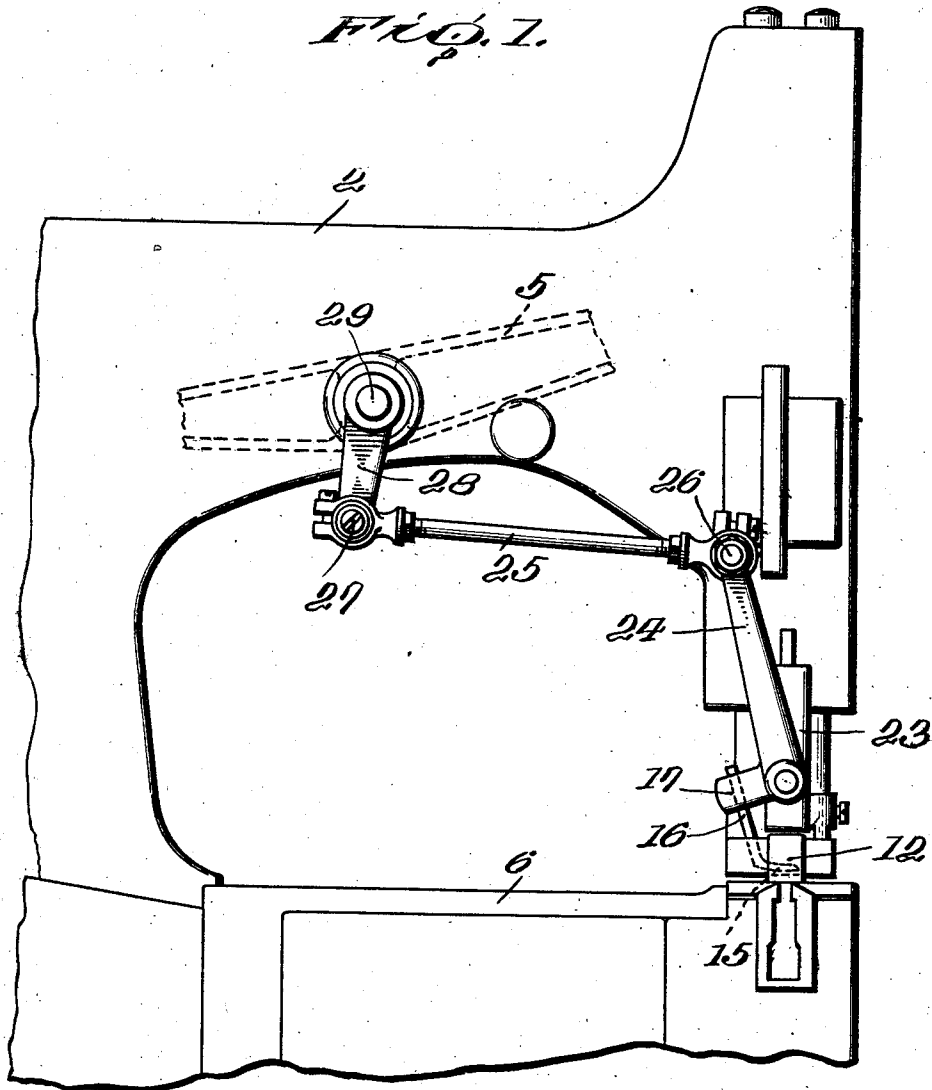

Inventor

Friedrich Lutz

By Shertwout, Mason & Porter

Attorneys

UNITED STATES PATENT OFFICE

2,014,687

SEWING MACHINE

Friedrich Lutz, Stuttgart, Germany, assignor to
Union Special Maschinenfabrik, G. m. b. H.,
Stuttgart, Germany

Application August 21, 1933, Serial No. 686,151
In Germany December 9, 1932

5 Claims. (Cl. 112—154)

The invention relates to new and useful improvements in sewing machines, and more particularly to the stitch forming devices thereof.

An object of the invention is to provide a means for supporting the needle thread between stitches during the formation of the stitch, which supporting means is withdrawn so as to release the thread for the setting of the stitch.

In the drawings which show by way of illustration one embodiment of the invention—

Figure 1 is a view from the rear of the machine showing the sewing machine more or less diagrammatically with the improvements added thereto;

Fig. 2 is a vertical sectional view substantially on the line of feed and showing a portion only of the sewing machine;

Fig. 3 is a plan view showing a portion of the machine in broken lines, a portion of the machine in horizontal section, and the improvements in top plan, and

Fig. 4 is a view partly in plan and partly in section from the front of the machine, the section being taken through the presser foot directly in rear of the needle.

Considerable difficulty has been experienced in producing a strong seam of neat appearance, especially in sewing paper material, such as paper bags, with a cross thread such as jute or sisal, which thread has little or no elasticity. The thread often cuts the paper between the needle punctures therein, particularly when the needle thread is placed under sufficient tension to make a relatively tight stitch. The present invention has to do with an attachment to a chain stitch sewing machine which includes a finger that is placed in rear of the needle so that the needle on its down stroke will lay the thread between the previous stitch puncture and the stitch puncture about to be made over the finger, and the finger supports the thread during the concatenating of the thread loops, after which the finger is withdrawn so that on the up stroke of the needle, the thread loops will be drawn into a substantially tight concatenation. This relieves all cutting strain of the thread on the material between the needle punctures and permits a relatively tight stitch to be made. Furthermore, when there is no material being stitched, the finger will support the thread and aid in chaining between stitched articles.

Referring more in detail to the drawings, the sewing machine which is illustrated more or less diagrammatically, includes a standard 1, and an overhanging arm 2 carried thereby in which the

needle bar 3 reciprocates. Said needle bar carries a needle 4. The needle bar is reciprocated by means of a needle lever 5. Beneath the overhanging arm is a work supporting arm 6 in which is located a feeding mechanism including a feed dog 7 which is of the usual construction. Cooperating with the needle beneath the work support is a thread carrying looper 8 mounted on a carrier 9 which is pivoted for oscillation on a looper support 10. The looper is given the usual movements into and out of the needle loops and a needle avoiding movement.

The material is held on the work support by a presser foot 11. Said presser foot has an upturned toe 12 and an opening 13 through which the needle passes. Directly in rear of the needle opening 13, the presser foot is provided with a recess 14 which extends down into the presser foot, leaving only a thin portion of metal between the recess and the bottom of the foot. Mounted for oscillation in a plane at right angles to the feed is a finger 15 carried by a shank portion 16 which is adjustably attached to an arm 17. The arm 17 is carried by a yoke member 18. This yoke member is provided with sleeves 19 and 20. The sleeve 19 is journaled on a bearing carried by a bolt 21 which extends through the shank 22 of the presser foot 11. Mounted on the presser foot is an upstanding frame member 23 and the sleeve 20 is journaled on a pin carried by this member 23. Thus it is that the finger can oscillate about a pivotal axis which is directly over the line of feed and intersects the path of reciprocation of the needle.

The finger 15 is timed in its movements so that it moves across the line of feed when the needle is in the upper portion of its down stroke, and the finger will, therefore, pass between the needle thread running from the eye of the needle to the previous stitch and the path of reciprocation of the needle, so that as the needle continues to descend, it will lay the thread over the finger, and the finger will support the thread as the needle passes on down to the lower end of its stroke. This takes all strain off the material between the needle punctures. On the up stroke of the needle, the finger is oscillated so that it is withdrawn from beneath the thread, releasing the same, so that as the feed of the fabric takes place, and the needle passes on to the upper end of its stroke, the thread loops which have been concatenated will be drawn down tight, setting the stitch. Inasmuch as the finger oscillates about a pivot axis which is directly over the line of feed said finger moves in a direction substan-

tially parallel with the surface of the fabric. It is relatively smooth and small, and while it serves as a support for the thread during the down stroke of the needle and over which the thread is drawn it may be readily withdrawn to permit the drawing down and the setting of the stitch as noted above.

The yoke 18 carrying this finger 15 is provided with an upstanding arm 24. A link 25 is pivoted at 26 to said arm, and is also pivoted at 27 to an arm 28 which is attached to the shaft 29, and this shaft 29 is fixed to the needle lever 5 forming a support for the needle lever and is oscillated by the needle lever. When the needle lever 5 is turned in a clockwise direction as viewed in Fig. 1, the finger 15 will be projected across the line of feed and between the needle thread and the needle, as described above. This is on the downward movement of the needle, and when the needle is retracted, then the lever 5 will turn in a counter-clockwise direction, and pushing on the link 25 will swing the yoke so as to retract the finger.

From the above it will be apparent that a means has been provided which supports the thread between the needle punctures while the needle is moving to the lower end of its stroke so as to take all strain off the material being stitched. If there is no material being stitched, the thread will be supported and insure a concatenation of the thread loops and the forming of enchaind stitches between stitched articles. The finger moves very close to the upper face of the material being stitched, due to the fact that the presser foot is recessed so as to provide a clearance space in which the finger swings. While the thread is supported, it is not unduly extended, so that the needle and the usual thread controlling devices cooperating therewith can take up the slack created in the thread by the supporting finger and draw the stitches tight when the finger releases the thread.

It is obvious that minor changes in the details of construction and the arrangement of the parts may be made without departing from the spirit of the invention as set forth in the appended claims.

Having thus described the invention, what I claim as new and desire to secure by Letters-Patent, is—

1. The combination of a needle, a complementary stitch forming device cooperating therewith for forming stitches, means located in rear of the needle over which the needle thread between stitches is laid, so that the thread is supported thereby on the down stroke of the needle, and means for moving said thread supporting means in a direction substantially parallel with the surface of the fabric for releasing the thread

whereby the needle on its up stroke may set the stitch and draw the threads into firm contact with the fabric being stitched.

2. The combination of a needle, a thread carrying looper cooperating therewith for forming stitches, a thread finger located in rear of the needle over which the needle thread between stitches is laid so that the thread is supported thereby on the down stroke of the needle, and means for moving said finger in a direction substantially parallel with the surface of the fabric and from beneath the thread for releasing the same so that the needle on its up stroke will set the stitch and draw the threads into firm engagement with the fabric being stitched

3. The combination of a needle, a thread carrying looper cooperating therewith for forming stitches, a smooth thread finger located in rear of the needle, means for supporting said thread finger whereby said finger moves on substantially a line parallel with the surface of the fabric, means for oscillating said thread finger in timing with the reciprocation of the needle so that said thread finger is passed between the needle thread and the path of the needle while the needle is on its down stroke whereby said needle as it moves to the lower end of its stroke draws said needle thread between needle punctures over said finger, said finger being retracted from beneath the thread on the up stroke of the needle so as to permit the stitches to be set and the threads drawn into firm contact with the fabric being stitched.

4. The combination of a work support, a presser foot, a needle, a thread carrying looper cooperating with said needle, a needle thread supporting finger located above the presser foot and in rear of the needle, and means for oscillating said thread finger in a direction substantially parallel with the surface of the fabric whereby said finger is moved between the needle thread and the needle on the down stroke of the needle for supporting said thread and is retracted on the up stroke of the needle for permitting the setting of the stitches.

5. The combination of a work support, a presser foot having a needle opening therethrough and a recess in its upper face in rear of said opening, a needle, a thread carrying looper cooperating with said needle, a thread supporting finger mounted for oscillation in substantially a vertical plane in rear of the needle and in said recess, means for oscillating said finger in a direction substantially parallel with the surface of the fabric whereby said finger is passed between the needle thread and the needle on the down stroke of the needle for supporting the thread between needle punctures and is retracted to permit the needle on its up stroke to set the stitches.

FRIEDRICH LUTZ.