

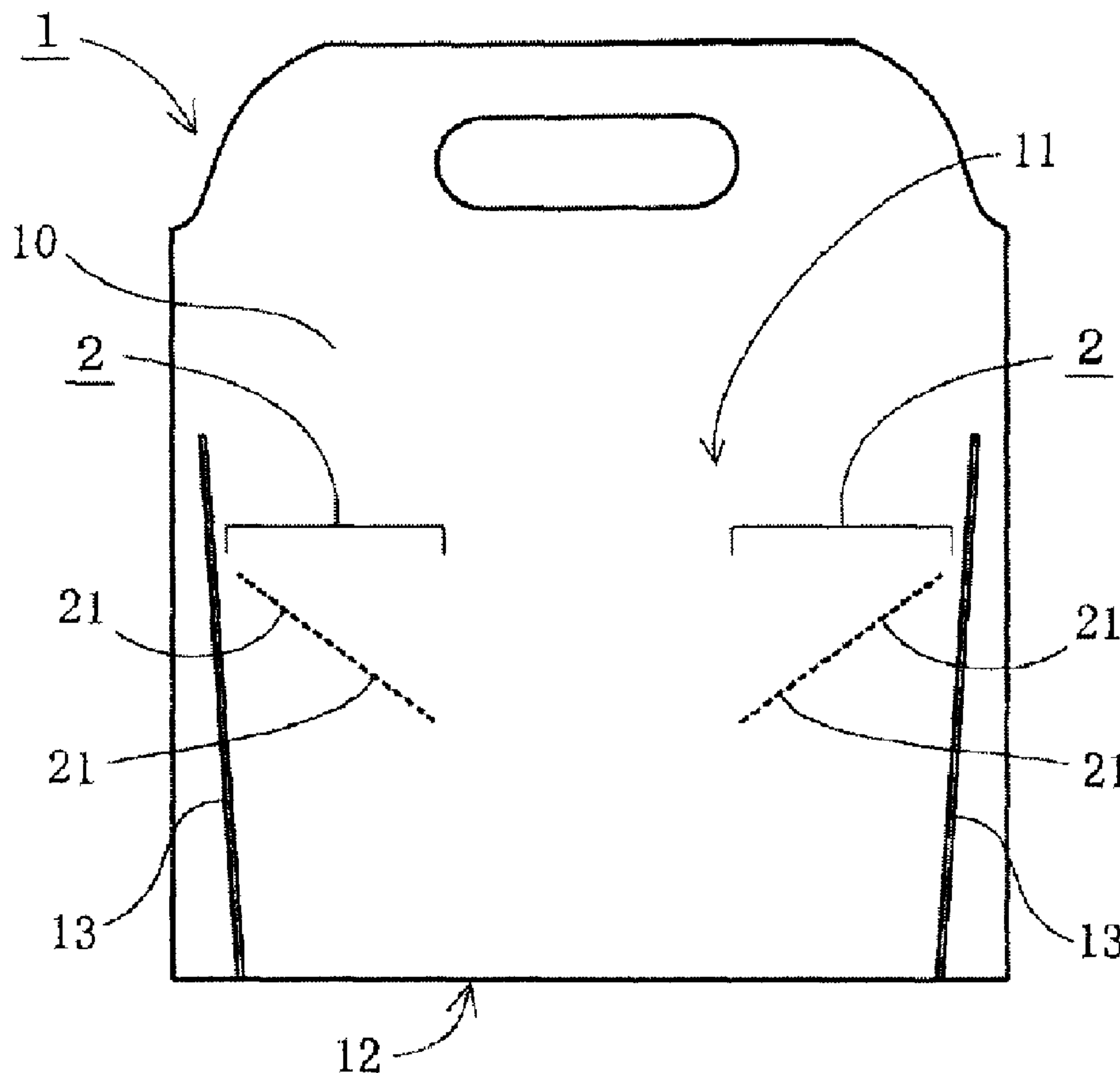

(86) **Date de dépôt PCT/PCT Filing Date:** 2016/06/08
 (87) **Date publication PCT/PCT Publication Date:** 2017/06/16
 (85) **Entrée phase nationale/National Entry:** 2016/10/17
 (86) **N° demande PCT/PCT Application No.:** JP 2016/067142
 (30) **Priorité/Priority:** 2015/12/16 (JP2015-245508)

(51) **Cl.Int./Int.Cl. B65D 75/52** (2006.01)
 (71) **Demandeur/Applicant:**
GARUTSU CO., LTD., JP
 (72) **Inventeur/Inventor:**
MIYAMOTO, TAKEHISA, JP
 (74) **Agent:** RICHES, MCKENZIE & HERBERT LLP

(54) **Titre : SAC DE TRANSPORT DE CONTENANT A FERMETURE ETANCHE**
 (54) **Title: TIGHT FASTENING TYPE SIZE-FREE CONTAINER CARRYING BAG**



(57) **Abrégé/Abstract:**

[Object] Provided is a tight fastening type size-free container carrying bag which has a simple configuration, can be manufactured at a low cost, and can be reliably fit to various shapes of containers size freely to stably hold the containers. [Solving Means]

(57) Abrégé(suite)/Abstract(continued):

Employed is a technical means corresponding to a bag body (1) in which a pair of sheet materials (10, 10) made of a thermoplastic resin material faces and overlaps each other, an opening (11) is formed at a top portion, and a bottom surface (12) is included at a bottom portion, wherein at least one container holding portion is formed in the bag body (1), wherein a holding zone (2) in which a plurality of spot joining portions (21, 21, ...) formed by joining inner surfaces of both the sheet materials (10, 10) of the bag body (1) each other in dot shapes is provided is formed in the container holding portion.

ABSTRACT

[Object] Provided is a tight fastening type size-free container carrying bag which has a simple configuration, can be manufactured at a low cost, and can be reliably fit to various shapes of containers size freely to stably hold the containers.

[Solving Means] Employed is a technical means corresponding to a bag body (1) in which a pair of sheet materials (10, 10) made of a thermoplastic resin material faces and overlaps each other, an opening (11) is formed at a top portion, and a bottom surface (12) is included at a bottom portion, wherein at least one container holding portion is formed in the bag body (1), wherein a holding zone (2) in which a plurality of spot joining portions (21, 21, ...) formed by joining inner surfaces of both the sheet materials (10, 10) of the bag body (1) each other in dot shapes is provided is formed in the container holding portion.

DESCRIPTION

TIGHT FASTENING TYPE SIZE-FREE CONTAINER CARRYING BAG

TECHNICAL FIELD

[0001] The present invention relates to an improvement in a container carrying tool, and more specifically, to a tight fastening type size-free container carrying bag which has a simple configuration, can be manufactured at a low cost, and can be reliably fit to various shapes of containers size freely to stably hold the containers.

BACKGROUND ART

[0002] When a beverage such as coffee and juice or food such as fish cake and soup is put in a temporary container (having a simple disposable type not sealed by a stopper) and taken out in a convenience store, a fast-food restaurant, or the like, it may be convenient if this temporary container can be stably carried without being directly held by a hand.

[0003] First, directly putting the temporary container in a bag is considered as such a carrying scheme. However, there is lack of stability, and there is a concern that the temporary container may tilt inside the bag, and contents such as the beverage or the soup may leak.

[0004] In addition, there is a scheme in which a mount having a hole of cardboard and the like is spread at the bottom of the bag, and the temporary container is erected in the hole in order to maintain a position of the temporary

container. However, there have been problems that it costs to stock the mount, a setting operation requires an effort, and it takes time to provide goods. [0005] Further, a bag that can carry a temporary container in a portable type is disclosed (for example, see Patent Document 1). However, only one temporary container can be carried per bag, and only a single size can be handled. Furthermore, since a main body of the temporary container is exposed to the outside, there is a concern that the temporary container may be stained, or an object around the temporary container may be stained when contents of a beverage, soup, and the like are leaked by mistake.

[0006] In addition, a bag is disclosed in which an opening provided in a holding piece at an opening of the bag is inserted into a container (bottle) (for example, see Patent Document 2). However, an operation of inserting the opening into the container each time goods are provided is extremely annoying. In particular, the operation is significantly difficult in the case of a tapered temporary container such as a beverage cup in which an opening diameter at the top portion is large.

[0007] In addition, a temporary container and a carrying bag are temporary and used up after being used from a store to a home or the like, and thus a simple configuration and a low cost are essential, which are required to be compatible with reliable holding performance.

CITATION LIST

PATENT DOCUMENT

[0008] Patent Document 1: JP 2008-80072 A

Patent Document 2: JP 60-182345 U

SUMMARY OF THE INVENTION

PROBLEM TO BE SOLVED BY THE INVENTION

[0009] The invention has been conceived in view of the fact that a conventional container carrying tool has the above-mentioned problem, and an object of the invention is to provide a tight fastening type size-free container carrying bag which has a simple configuration, can be manufactured at a low cost, and can be reliably fit to various shapes of containers size freely to stably hold the containers.

MEANS FOR SOLVING PROBLEM

[0010] Means adopted by the inventor to solve the above-mentioned technical problem are described below with reference to accompanying drawings.

[0011] That is, the invention completed a tight fastening type size-free container carrying bag by employing a technical means corresponding to a bag body 1 in which a pair of sheet materials 10, 10 made of a thermoplastic resin material faces and overlaps each other, an opening 11 is formed at a top portion, and a bottom surface 12 is included at a bottom portion, wherein at least one container holding portion is formed in the bag body 1, wherein a holding zone 2 in which a plurality of spot joining portions 21, 21, ... formed by joining inner surfaces of both the sheet materials 10, 10 of the bag body 1 each other in dot shapes is provided is formed in the container holding portion, a main body of a container C is pressed against at least a portion of a spot joining portion 21 in the holding zone 2 and a spot joining portion 21 in a pressed part is allowed to be peeled off when the container C is inserted from

the opening 11, and movement of the container C inside the bag body 1 is regulated to allow the container C to be stably supported and carried when a remaining endmost spot joining portion 21 adheres to an outer circumferential surface of the container C in an inserted state, and the outer circumferential surface of the container C is tightened between the sheet materials 10.

[0012] In addition, to solve the above-mentioned problem, in addition to the above means, the invention may employ a technical means as necessary in which a container insertion portion is formed at a center of the container holding portion of the bag body 1, and the holding zone 2 is substantially symmetrically provided on each of right and left sides of the container insertion portion.

[0013] Furthermore, to solve the above-mentioned problem, in addition to the above means, the invention may employ a technical means as necessary in which a stopper 3 obtained when the inner surfaces of both the sheet materials 10, 10 of the bag body 1 adhere to each other is formed on an outside of the holding zone 2.

EFFECT OF THE INVENTION

[0014] The invention is a bag body in which a pair of sheet materials made of a thermoplastic resin material faces and overlaps each other, an opening is formed at a top portion, and a bottom surface is included at a bottom portion. When at least one container holding portion is formed in the bag body, and a holding zone in which a plurality of spot joining portions formed by joining inner surfaces of both the sheet materials of the bag body each other in dot shapes is provided is formed in the container holding portion, a main body of a

container is pressed against at least a portion of a spot joining portion in the holding zone and a spot joining portion in a pressed part is allowed to be peeled off when the container is inserted from the opening, and movement of the container inside the bag body is regulated to allow the container to be stably supported and carried when a remaining endmost spot joining portion adheres to an outer circumferential surface of the container in an inserted state, and the outer circumferential surface of the container is tightened between the sheet materials.

[0015] Therefore, a tight fastening type size-free container carrying bag of the invention has a simple configuration and may be manufactured at a low cost, and thus is significantly suitable for use for a temporary (used up, disposable) object from a store to a home or the like, such as carrying of a temporary container such as a beverage cup.

[0016] In addition, since only a necessary portion of a spot joining portion is peeled off according to a shape of a container to be carried, various shapes of containers may be reliably and size freely fit thereto and stably held.

[0017] Further, since a carrying bag of the invention is disposable, the carrying bag becomes a dedicated one by conforming to a size of a temporary container to be carried without the need to join a peeled spot joining portion again. Thus, a manufacturing accuracy of a bag body may be decreased.

[0018] In addition, since a sheet material adheres to an outer circumferential surface of a container supported by a carrying bag of the invention, even a relatively vertically long beverage container which becomes inevitability substantially upright may be significantly stably carried.

[0019] Furthermore, since a plurality of containers may be carried by

increasing container holding portions as necessary, industrial usefulness is extremely large.

BRIEF DESCRIPTION OF DRAWINGS

[0020] Fig. 1 is a front cross-sectional view illustrating a configuration of a container carrying bag of an embodiment of the invention;

Fig. 2 is a front cross-sectional view illustrating a usage state of the container carrying bag of the embodiment of the invention;

Fig. 3 is a front cross-sectional view illustrating a usage state of the container carrying bag of the embodiment of the invention;

Fig. 4 is a front cross-sectional view illustrating a usage state of the container carrying bag of the embodiment of the invention;

Fig. 5 is a top cross-sectional view illustrating a container storing state of the container carrying bag of the embodiment of the invention;

Fig. 6 is a front cross-sectional view illustrating a configuration of the container carrying bag of the embodiment of the invention;

Fig. 7 is a front cross-sectional view illustrating a configuration of a modified example of the container carrying bag of the embodiment of the invention;

Fig. 8 is a front cross-sectional view illustrating a configuration of a modified example of the container carrying bag of the embodiment of the invention;

Fig. 9 is a front cross-sectional view illustrating a configuration of a modified example of the container carrying bag of the embodiment of the invention;

Fig. 10 is a front cross-sectional view illustrating a configuration of a modified example of the container carrying bag of the embodiment of the invention;

Fig. 11 is a front cross-sectional view illustrating a configuration of a modified example of the container carrying bag of the embodiment of the invention;

Fig. 12 is a front cross-sectional view illustrating a configuration of a modified example of the container carrying bag of the embodiment of the invention;

Fig. 13 is a front cross-sectional view illustrating a configuration of a modified example of the container carrying bag of the embodiment of the invention; and

Fig. 14 is a front cross-sectional view illustrating a configuration of a modified example of the container carrying bag of the embodiment of the invention.

MODE(S) FOR CARRYING OUT THE INVENTION

[0021] An embodiment of the invention will be described based on Fig. 1 to Fig. 14. In the figures, reference numeral 1 indicates a bag body, and reference numeral 2 indicates a holding zone. This holding zone 2 is a region having a predetermined area and including a plurality of spot joining portions 21, 21,

[0022] Then, when a tight fastening type size-free container carrying bag of the invention is configured, first, a pair of sheet materials 10 and 10 made of a thermoplastic resin material is superposed on each other by facing each other. In the present embodiment, a polyolefin resin such as polyethylene (PE),

polypropylene (PP), or polyethylene terephthalate (PET), nylon may be employed as this resin material.

[0023] In addition, the bag body 1 has an opening 11 formed at a top portion, and a bottom surface 12 at a bottom. As a scheme of superposing the sheet materials 10 and 10, the bag body 1 may be folded back on the bottom surface 12 to superpose the sheet materials 10 and 10. In this instance, a gusset is preferably formed on the bottom surface 12 to form a bag bottom, and a bottom surface of a container is placed on the gusset to increase stability while ensuring a capacity of the bag body. In addition, a handle part for holding the bag body 1 in a hand may be provided around the opening 11.

[0024] At least one container holding portion is formed in the bag body 1. The container holding portion refers to a unit part that holds one container. In addition, the holding zone 2 in which the spot joining portions 21, 21, ... formed by joining inner surfaces of the both sheet materials 10 and 10 of the bag body 1 to each other in dot shapes is formed in the container holding portion. A dot shape of the spot joining portion 21 is preferably included in a region of about a maximum of 1 cm², and is more preferably included in a region of about 2 to 3 mm².

[0025] While this holding zone 2 is the region having the predetermined area and includes the plurality of spot joining portions 21, 21, ..., a shape and an arrangement of the spot joining portion 21 have various modes as described below.

[0026] In addition, as a method of molding the spot joining portion 21, a die of a shape of the spot joining portion 21 in an arrangement designed in advance is molded and heat-pressed to a required position on a surface of the sheet

material 10. In this instance, when a heating temperature or a pressure welding time of the die is appropriately changed according to a property of matter such as a melting point of a material of the sheet material 10, peel strength may be adjusted. When the peel strength is excessively large, peeling fails at the time of pressing a container C, or the sheet material 10 peels off to cause a hole. Meanwhile, when the peel strength is excessively small, there is a concern that the spot joining portion 21 corresponding to an unintended position may peel off, and thus the container C may move inside the bag body 1.

[0027] <Arrangement example 1>

In this arrangement example, a container insertion portion is formed at a center of the container holding portion of the bag body 1, and the holding zone 2 is substantially symmetrically provided on each of right and left sides of this container insertion portion (see Fig. 1). The spot joining portions 21, 21, ... in the holding zone 2 are arranged to be linearly provided from an outer and upper side toward an inner and lower side, and the spot joining portion 21 and a gap having substantially the same size as a size of the spot joining portion 21 are alternately provided.

[0028] In addition, when the container C (two-dot chain line in the figure) is inserted from the opening 11 as illustrated in Fig. 2, a main body of the container C is pressed against at least a portion of the spot joining portion 21 in the holding zone 2 as illustrated in Fig. 3, and thus the spot joining portion 21 corresponding to this pressed part may be peeled off.

[0029] Thereafter, as illustrated in Fig. 4, until the container C reaches the bottom surface 12 of the bag body 1, the spot joining portion 21 at a

corresponding position is peeled off.

[0030] In this way, spot joining portions 21 pressed at the time of insertion are peeled off one by one. Finally, a remaining endmost spot joining portion 21 adheres to an outer circumferential surface of the container C in an inserted state, and the outer circumferential surface of the container C may be tightened by being wound around the sheet materials 10 and 10 (see Fig. 5).

[0031] In this way, movement of the container C inside the bag body 1 may be regulated, and the container C may be stably supported and carried.

[0032] In the present embodiment, the sheet material 10 of the bag body 1 may be configured by integrally stacking different thermoplastic resin materials, and only the inner surface of the sheet material 10 may be allowed to be peeled off. A known laminating method or adhesion using an adhesive may be adopted as a stacking scheme. In this way, penetration of the sheet material 10 may be prevented at the time of peeling, and a decrease in strength of the bag due to penetration (hole), a leakage of contents, and the like may be prevented.

[0033] In this instance, as a more specific combination, the sheet material 10 of the bag body 1 may be configured by integrally stacking thermoplastic resin materials having different melting points (for example, high density polyethylene (HDPE) and low density polyethylene (LDPE)), and a low-melting resin material (low density polyethylene) may be arranged at a predetermined position on the inner surface of the bag body 1, thereby allowing only a low-melting resin material portion of the sheet material 10 to be peeled off.

[0034] In addition, when such a stacked structure of the sheet material 10 is employed, only the low-melting resin material may be melted by performing processing (heat pressing and the like) at a temperature between a melting

point of a high-melting resin material and a melting point of the low-melting resin material in a manufacturing process. Thus, the spot joining portion 21 may be easily and reliably molded without damaging the sheet material 10.

[0035] <Arrangement example 2>

According to an arrangement example illustrated in Fig. 6, two straight rows of <Arrangement example 1>, in which the spot joining portions 21, 21, ... in the holding zone 2 are arranged to be linearly provided from an outer and upper side toward an inner and lower side, and the spot joining portion 21 and a gap having substantially the same size as a size of the spot joining portion 21 are alternately provided, are provided in parallel on each of right and left sides, thereby configuring the holding zone 2. In this way, support strength of the container may be improved.

[0036] <Arrangement example 3>

According to an arrangement example illustrated in Fig. 7 and Fig. 8, the spot joining portions 21, 21, ... in the holding zone 2 are arranged to be curvedly provided from an outer and upper side toward an inner and lower side, the spot joining portion 21 and a gap are alternately provided, and a size (length) of the spot joining portion 21 may be adjusted according to support strength of the container C.

[0037] <Arrangement example 4>

According to an arrangement example illustrated in Fig. 9, the spot joining portions 21, 21, ... in the holding zone 2 are arranged to be linearly provided from an outer side toward an inner side immediately beside the outer side, and the spot joining portion 21 and a gap having substantially the same size as a size of the spot joining portion 21 are alternately provided. Even

though an interval between the spot joining portions 21, 21, ... becomes narrower downward in the above arrangement example, the same effects may be obtained even when the spot joining portions 21, 21, ... are provided in a direction perpendicular to a container insertion direction as in the present arrangement example.

[0038] <Arrangement example 5>

According to an arrangement example illustrated in Fig. 10, referring to arrangement of the spot joining portions 21, 21, ... in the holding zone 2, a plurality of spot joining portions 21, 21, ... is provided at intervals within a region having a predetermined area excluding the container insertion portion on the inside. In this instance, the spot joining portion 21 has an arbitrary size and shape.

[0039] <Arrangement example 6>

According to an arrangement example illustrated in Fig. 11, in addition to the spot joining portions 21, 21, ... of <Arrangement example 1>, a stopper 3 obtained when the inner surfaces of the both sheet materials 10 and 10 of the bag body 1 adhere to each other is formed on an outside of the holding zone 2. In this way, even when all the spot joining portions 21, 21, ... are erroneously peeled off, great damage in which the container C falls inside the bag body 1 may be prevented. Arrangement of the spot joining portions 21, 21, ... at the time of providing the stopper 3 is not restricted to the illustrated arrangement.

[0040] <Arrangement example 7>

According to an arrangement example illustrated in Fig. 12, referring to arrangement of the spot joining portions 21, 21, ... in the holding zone 2, a

certain interval may be provided between the spot joining portion 21 on the outermost side and an adhesion portion 13 on a side of the bag body 1, and a pocket 14 may be formed therein. An appendage of a beverage or food accommodated in the container such as sugar, milk, a muddler may be inserted into the pocket 14 and held.

[0041] <Arrangement example 8>

According to an arrangement example illustrated in Fig. 13, each spot joining portion 21 in the holding zone 2 is formed in a curved shape having a short side and a long side. In this way, the short side may be pressed at the time of insertion of the container C to peel off a portion or a whole of the spot joining portion 21, and an outer surface of the container C may adhere to the long side and be supported.

[0042] Even though the invention is roughly configured as described above, the invention is not restricted to the illustrated embodiment, and may be variously changed within the scope of claims. For example, the size, the shape, and the number of spot joining portions 21 in the holding zone 2 may be appropriately changed.

[0043] In addition, the number of container holding portions is not restricted to one. Two container holding portions may be formed as illustrated in Fig. 14, or three or more container holding portions may be formed in the bag body 1, which belongs to the technical scope of the invention.

EXPLANATIONS OF LETTERS OR NUMERALS

[0044] 1: bag body

10: sheet material

11: opening

12: bottom surface

13: adhesion portion

14: pocket

2: holding zone

21: spot joining portion

21a: peeled spot joining portion

21b: remaining spot joining portion

3: stopper

C: container

CLAIMS

1. A tight fastening type size-free container carrying bag corresponding to a bag body (1) in which a pair of sheet materials (10, 10) made of a thermoplastic resin material faces and overlaps each other, an opening (11) is formed at a top portion, and a bottom surface (12) is included at a bottom portion, wherein at least one container holding portion is formed in the bag body (1),

wherein a holding zone (2) in which a plurality of spot joining portions (21, 21, ...) formed by joining inner surfaces of both the sheet materials (10, 10) of the bag body (1) each other in dot shapes is provided is formed in the container holding portion,

a main body of a container (C) is pressed against at least a portion of a spot joining portion (21) in the holding zone (2) and a spot joining portion (21) in a pressed part is allowed to be peeled off when the container (c) is inserted from the opening (11), and

movement of the container (C) inside the bag body (1) is regulated to allow the container (C) to be stably supported and carried when a remaining endmost spot joining portion (21) adheres to an outer circumferential surface of the container (C) in an inserted state, and the outer circumferential surface of the container (C) is tightened between the sheet materials (10).

2. The tight fastening type size-free container carrying bag according to claim 1, wherein a container insertion portion is formed at a center of the container holding portion of the bag body (1), and the holding zone (2) is substantially symmetrically provided on each of right and left sides of the

container insertion portion.

3. The tight fastening type size-free container carrying bag according to claim 1, wherein a stopper (3) obtained when the inner surfaces of both the sheet materials (10, 10) of the bag body (1) adhere to each other is formed on an outside of the holding zone (2).

FIG. 1

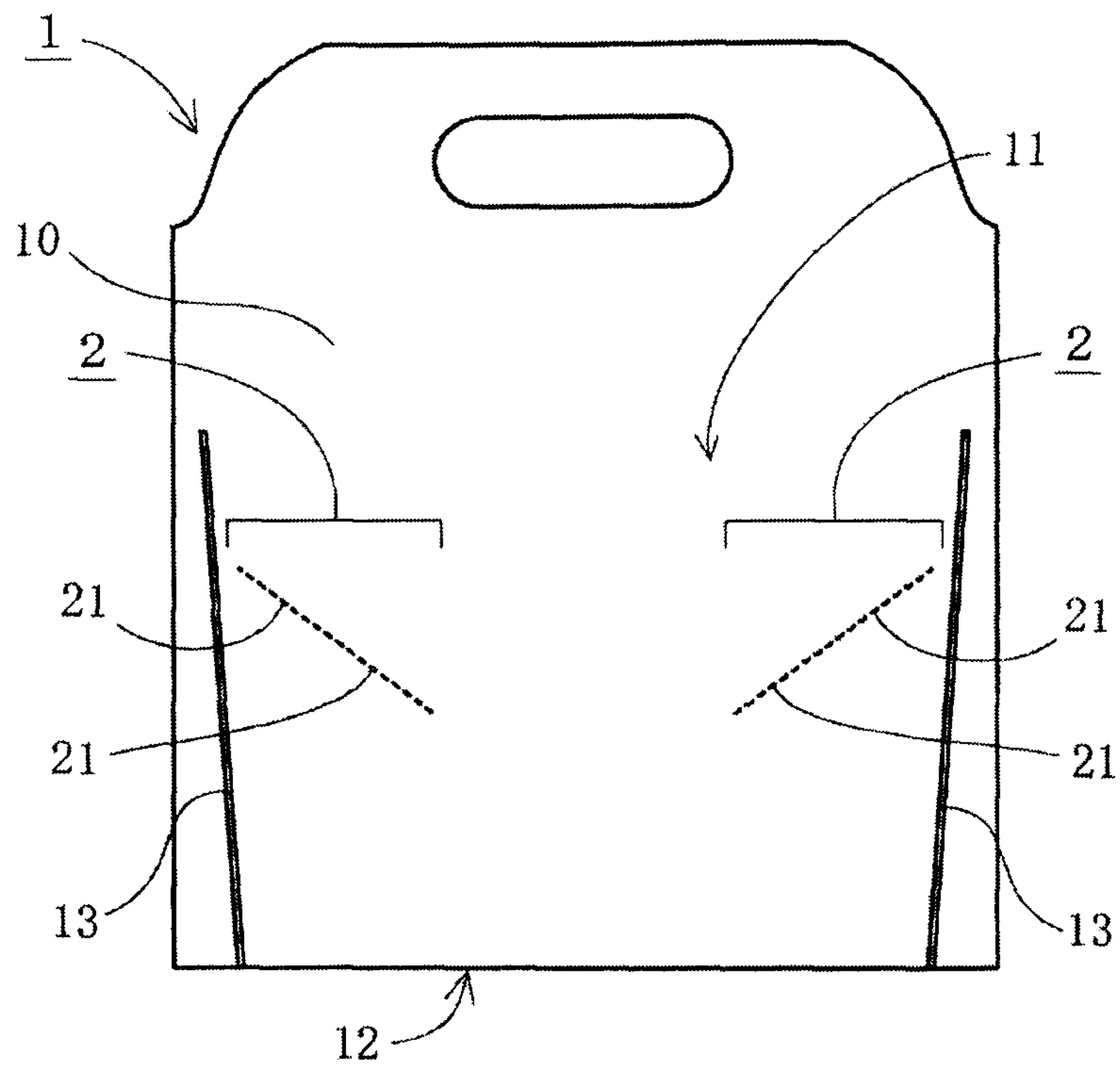

FIG. 2

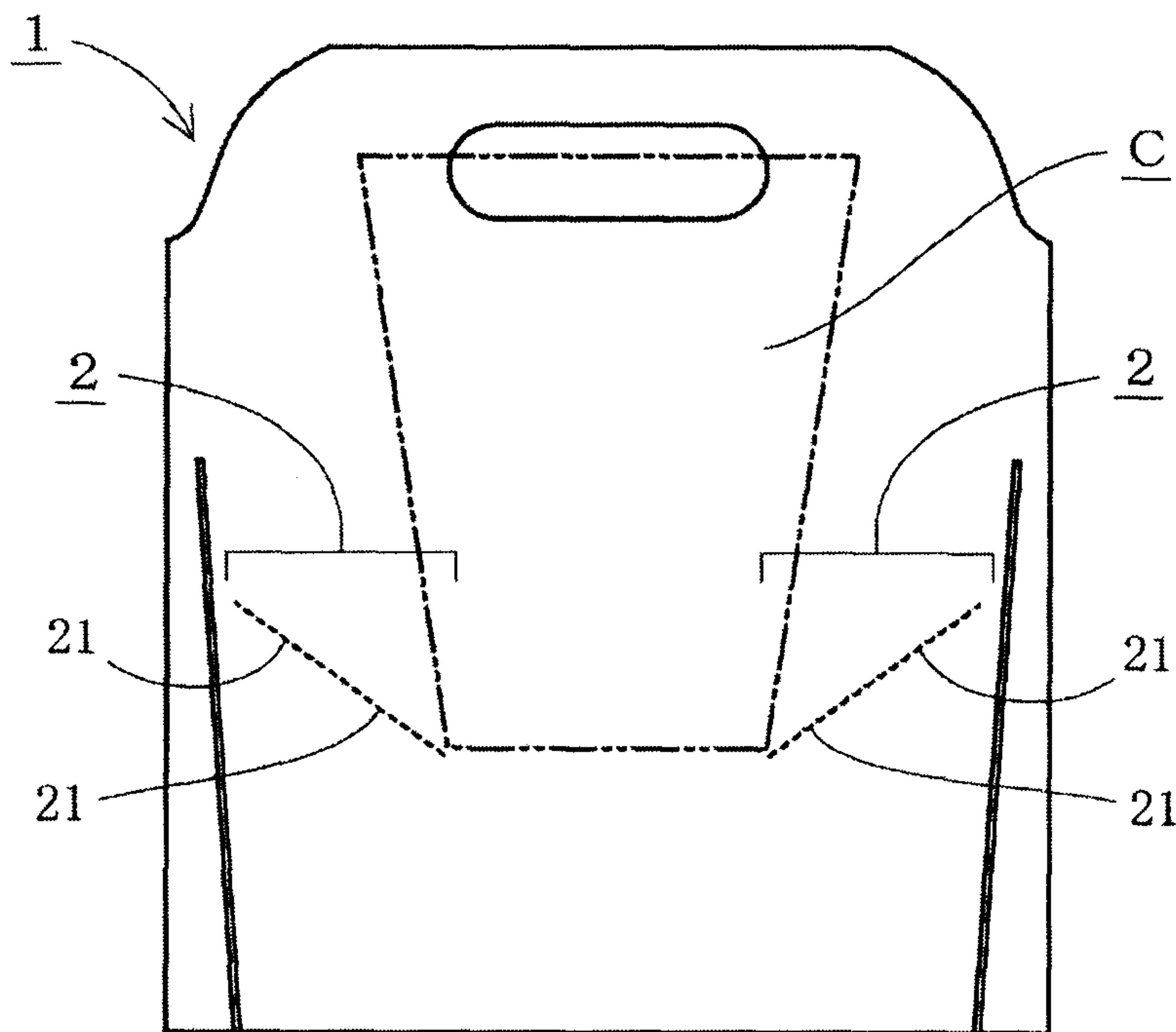

FIG. 3

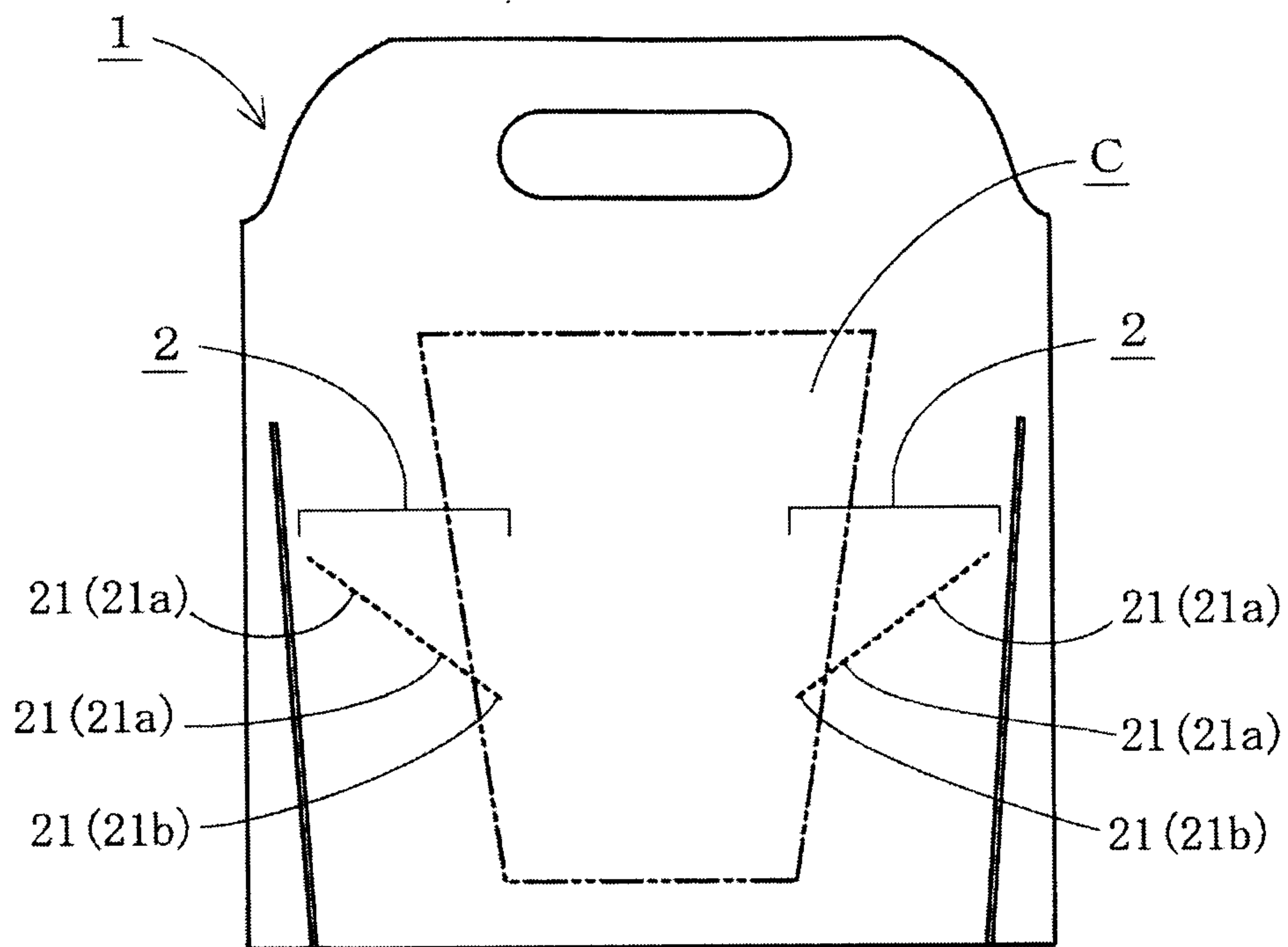

FIG. 4

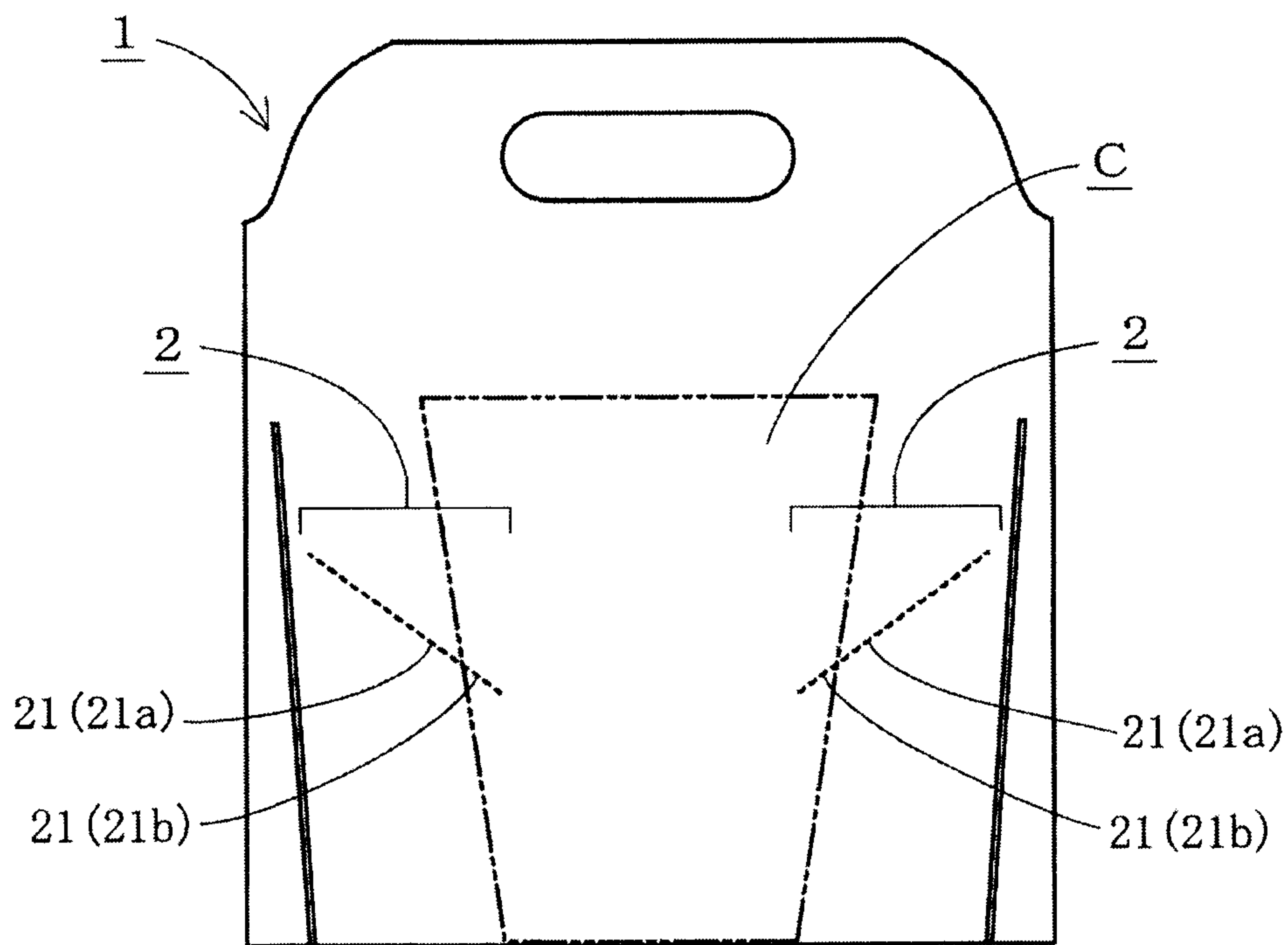

FIG. 5

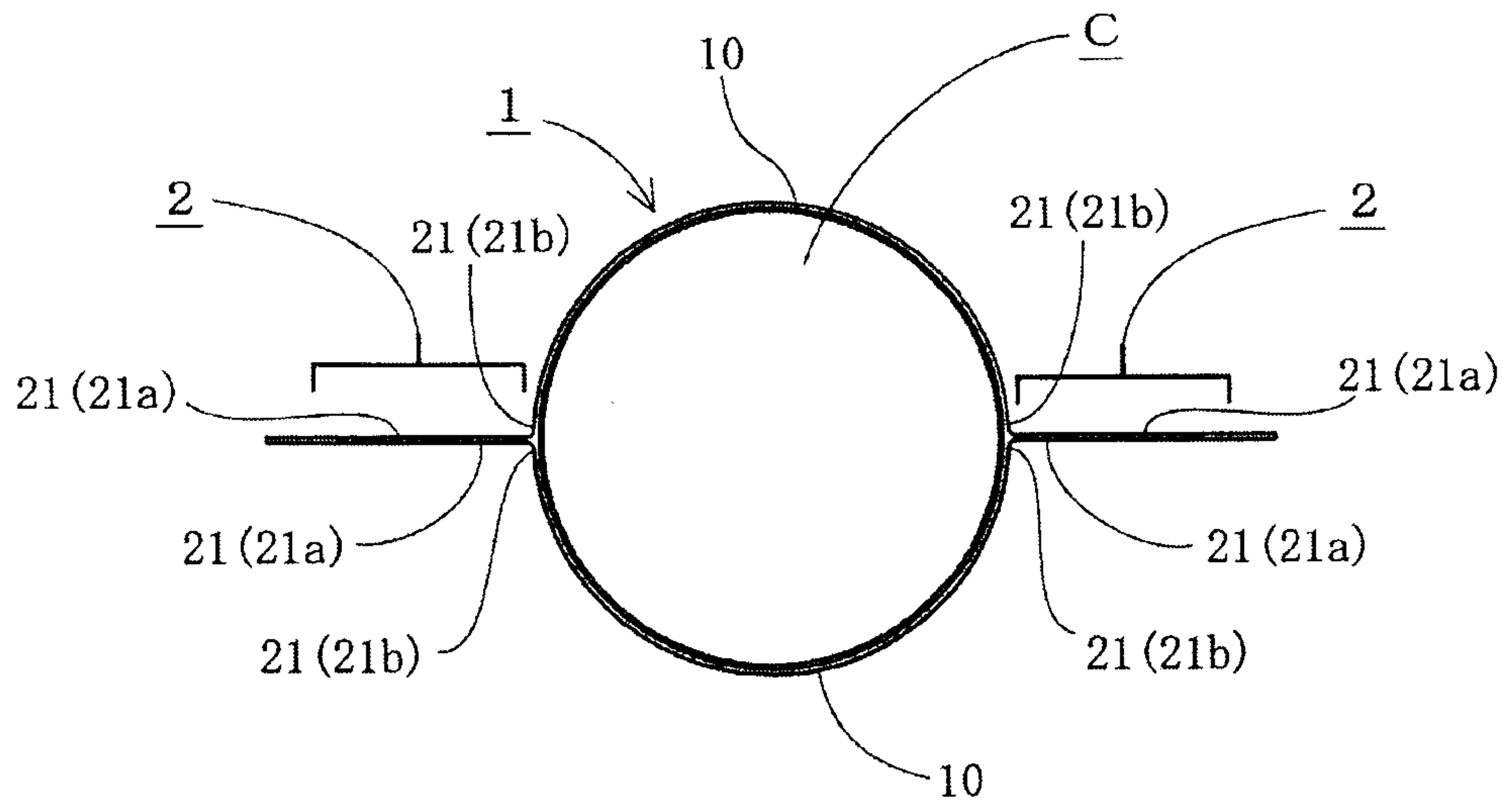

FIG. 6

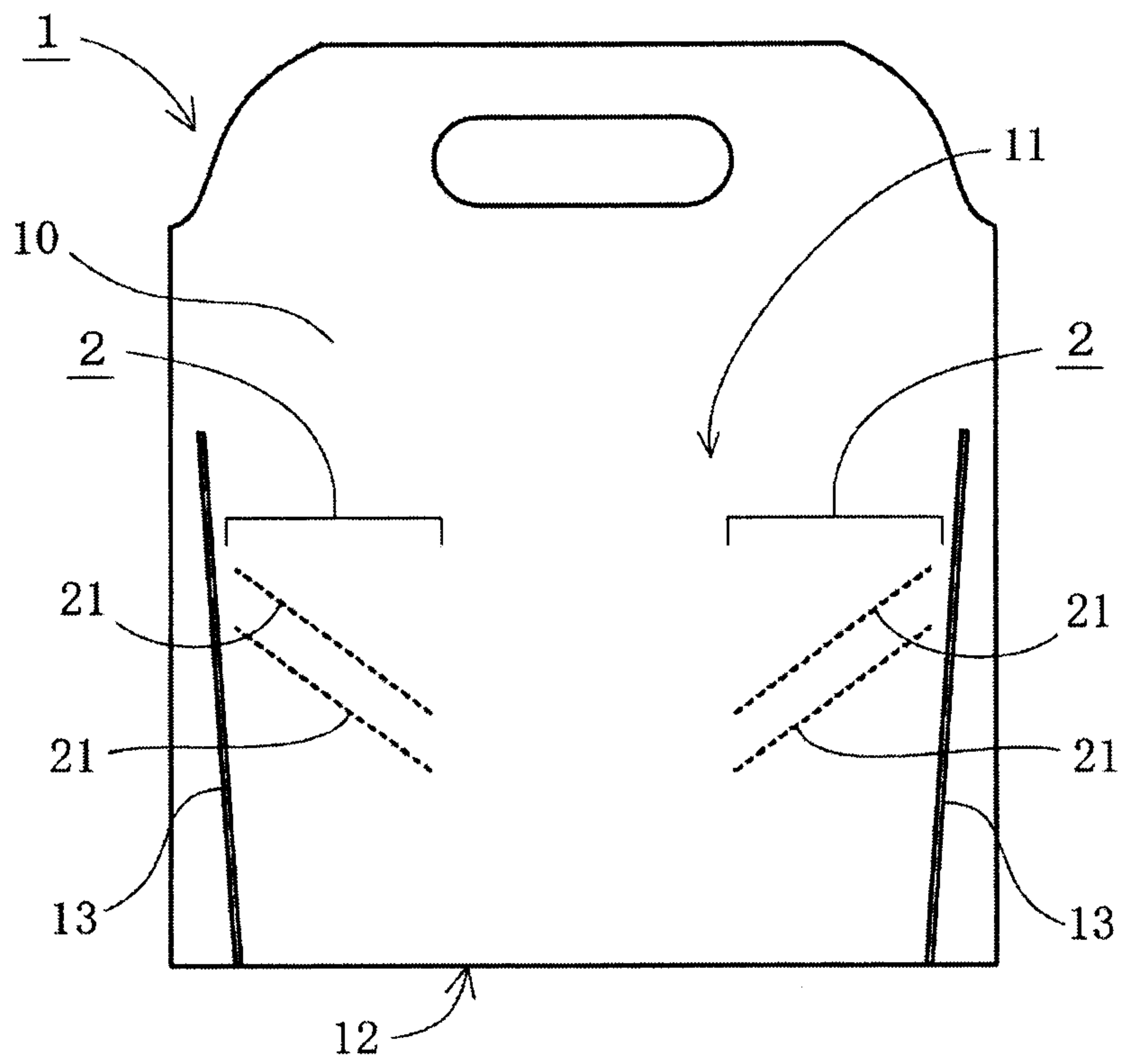

FIG. 7

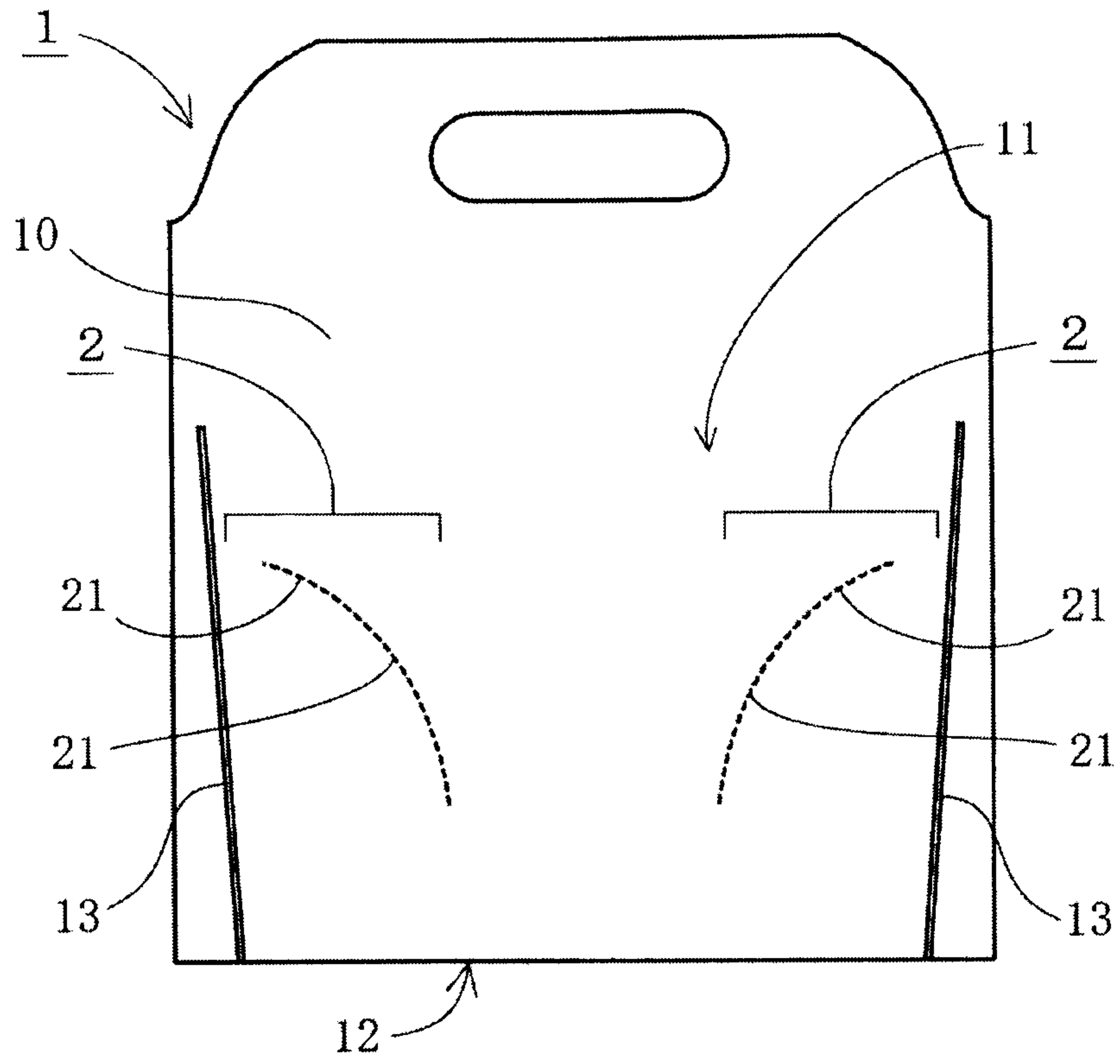

FIG. 8

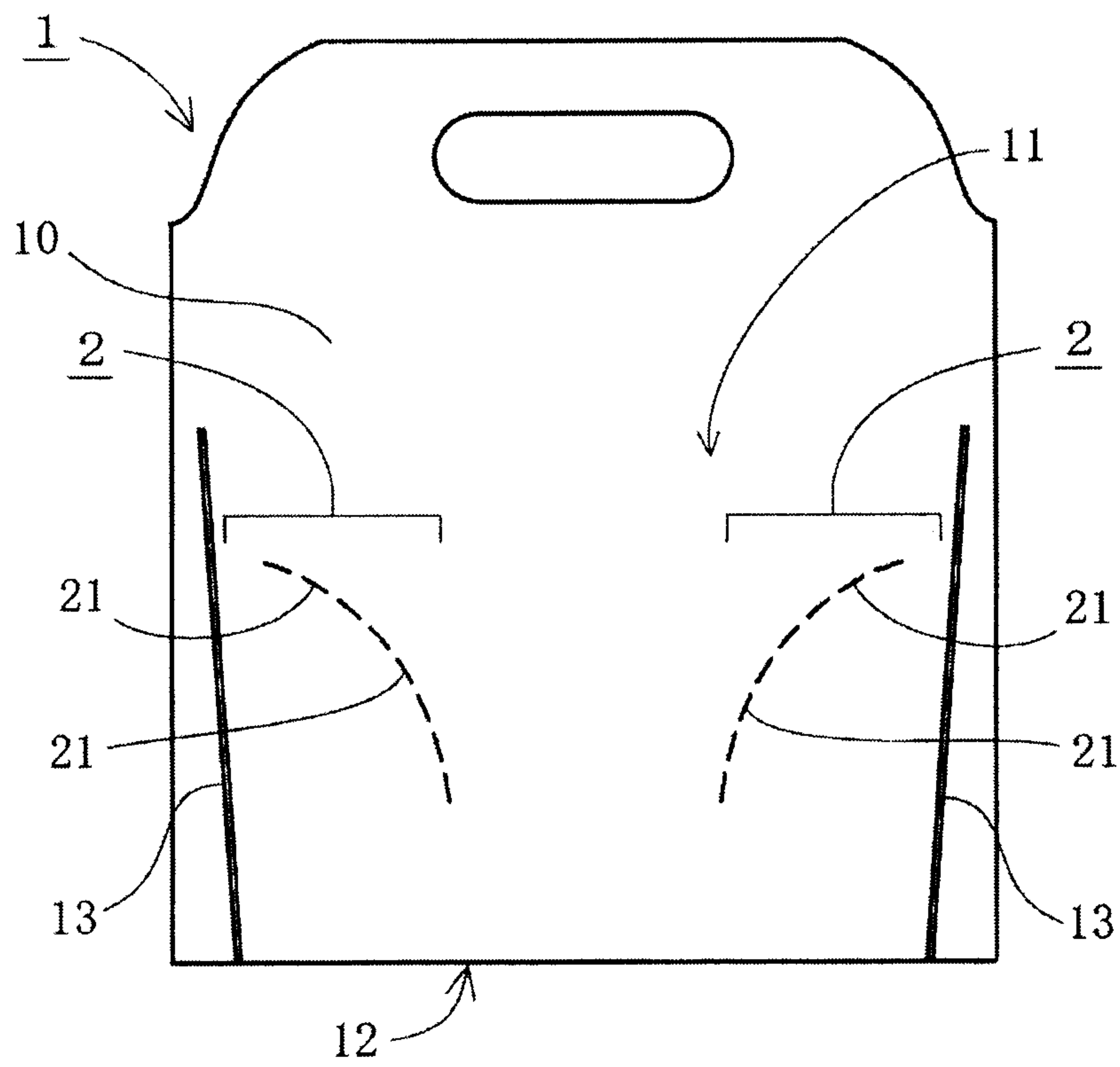

FIG. 9

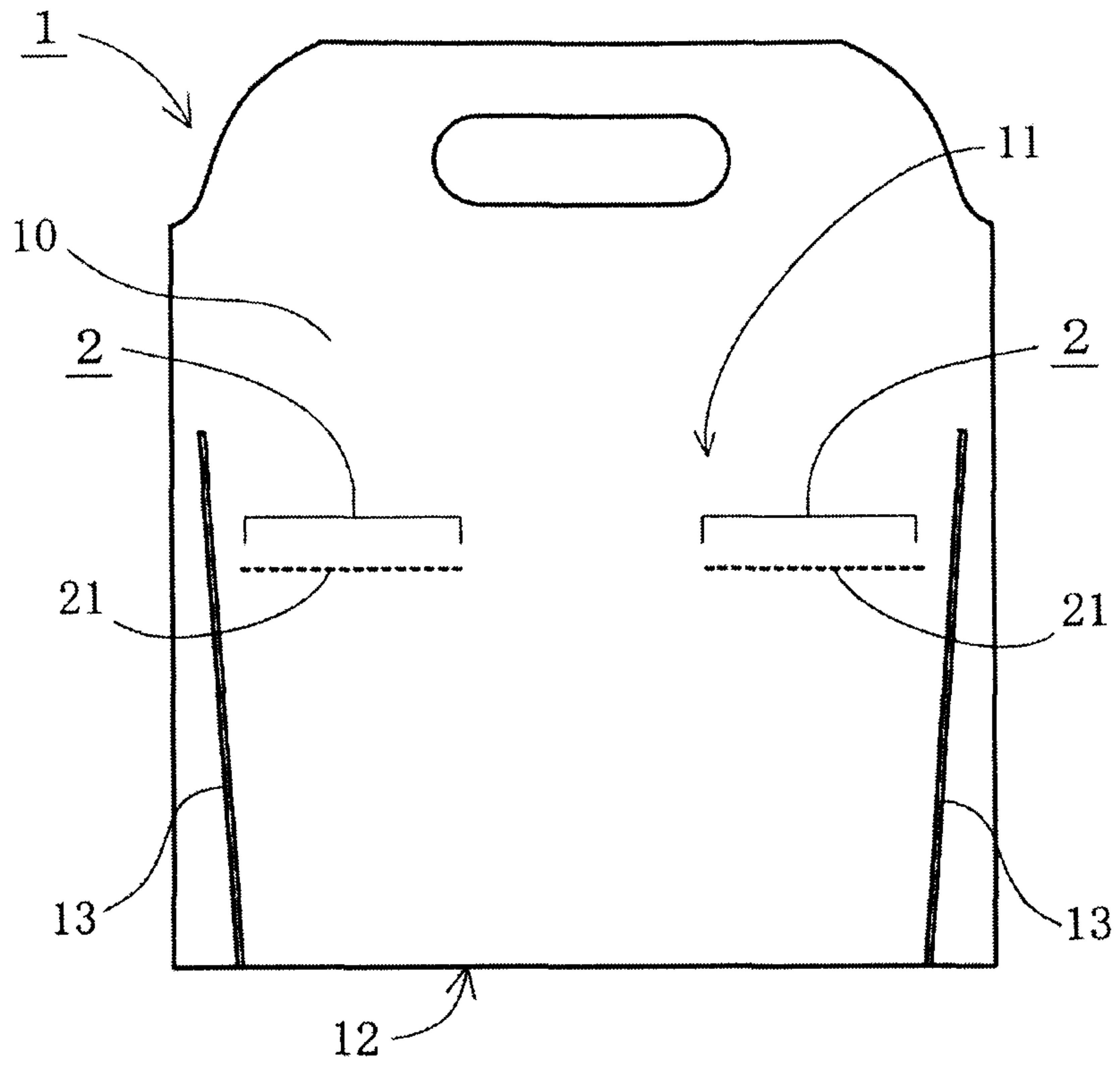

FIG. 10

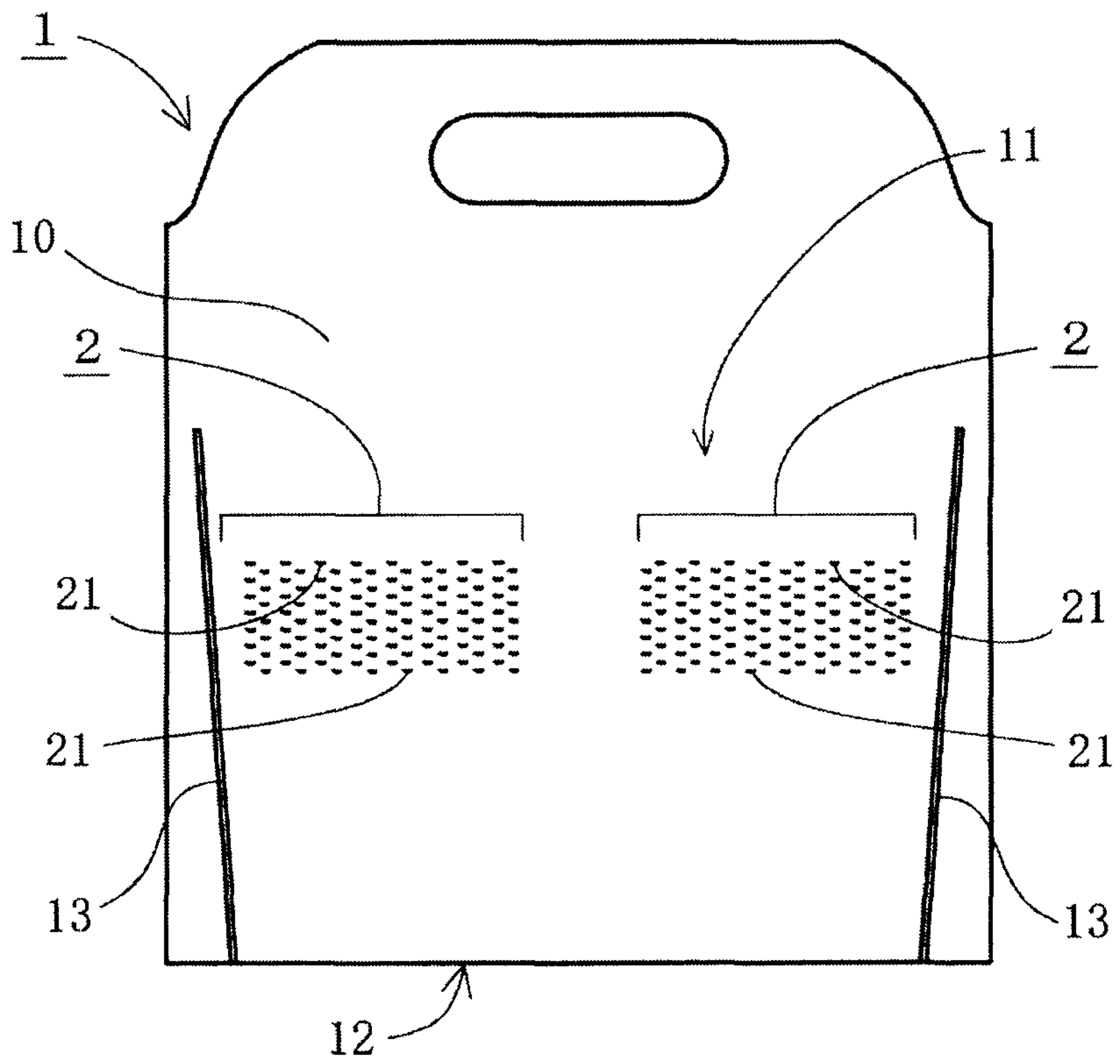

FIG. 11

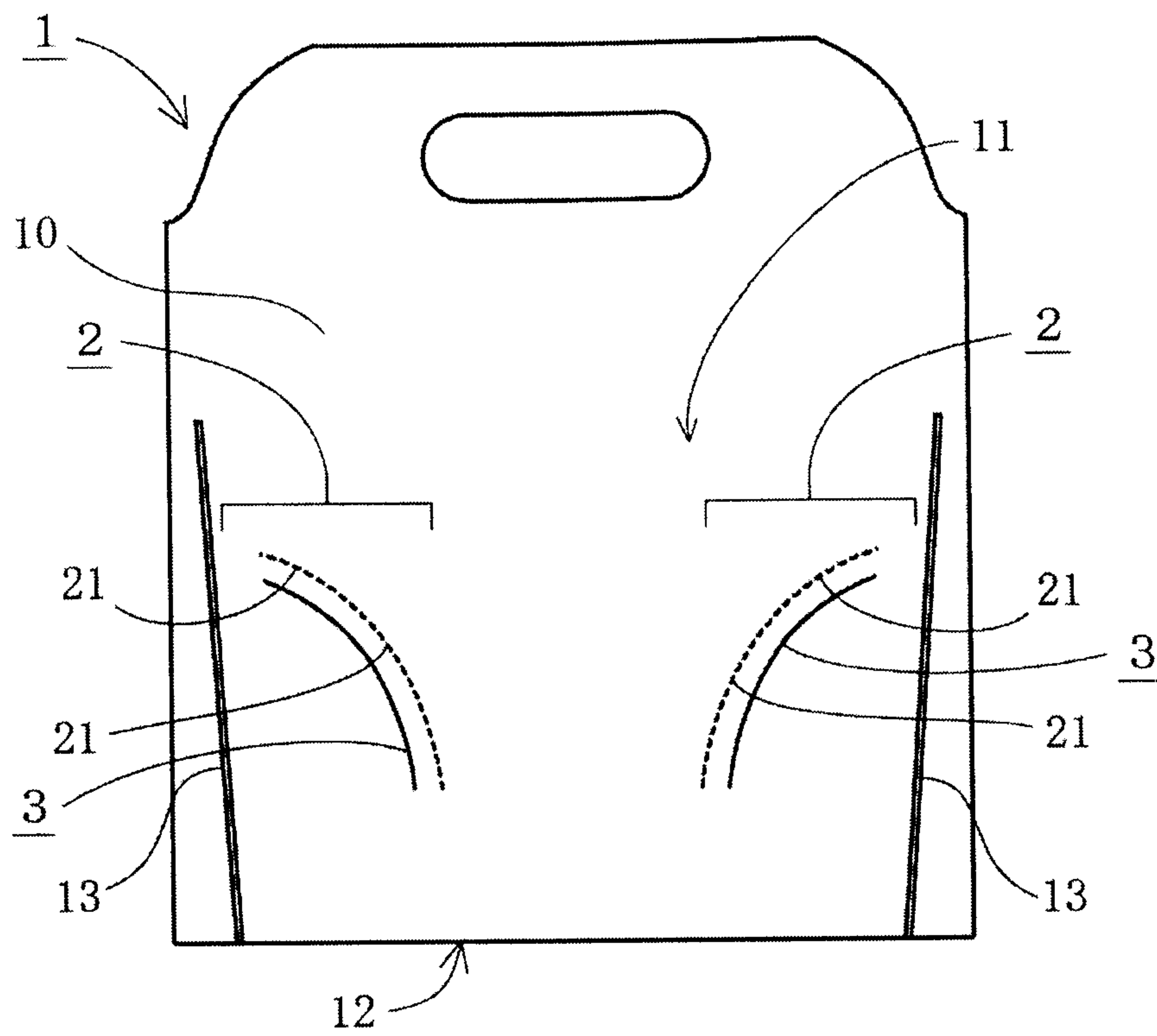

FIG. 12

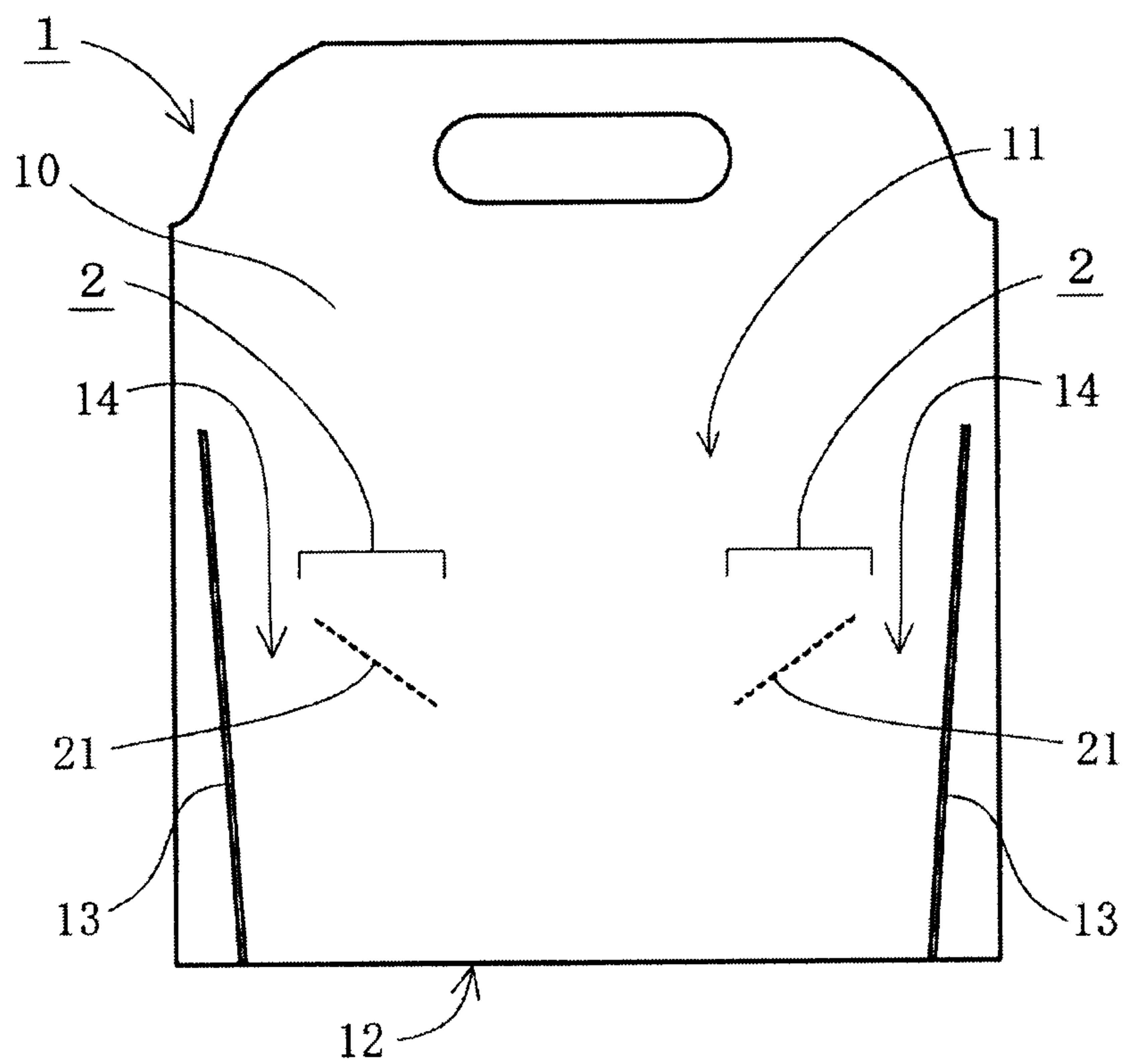

FIG. 13

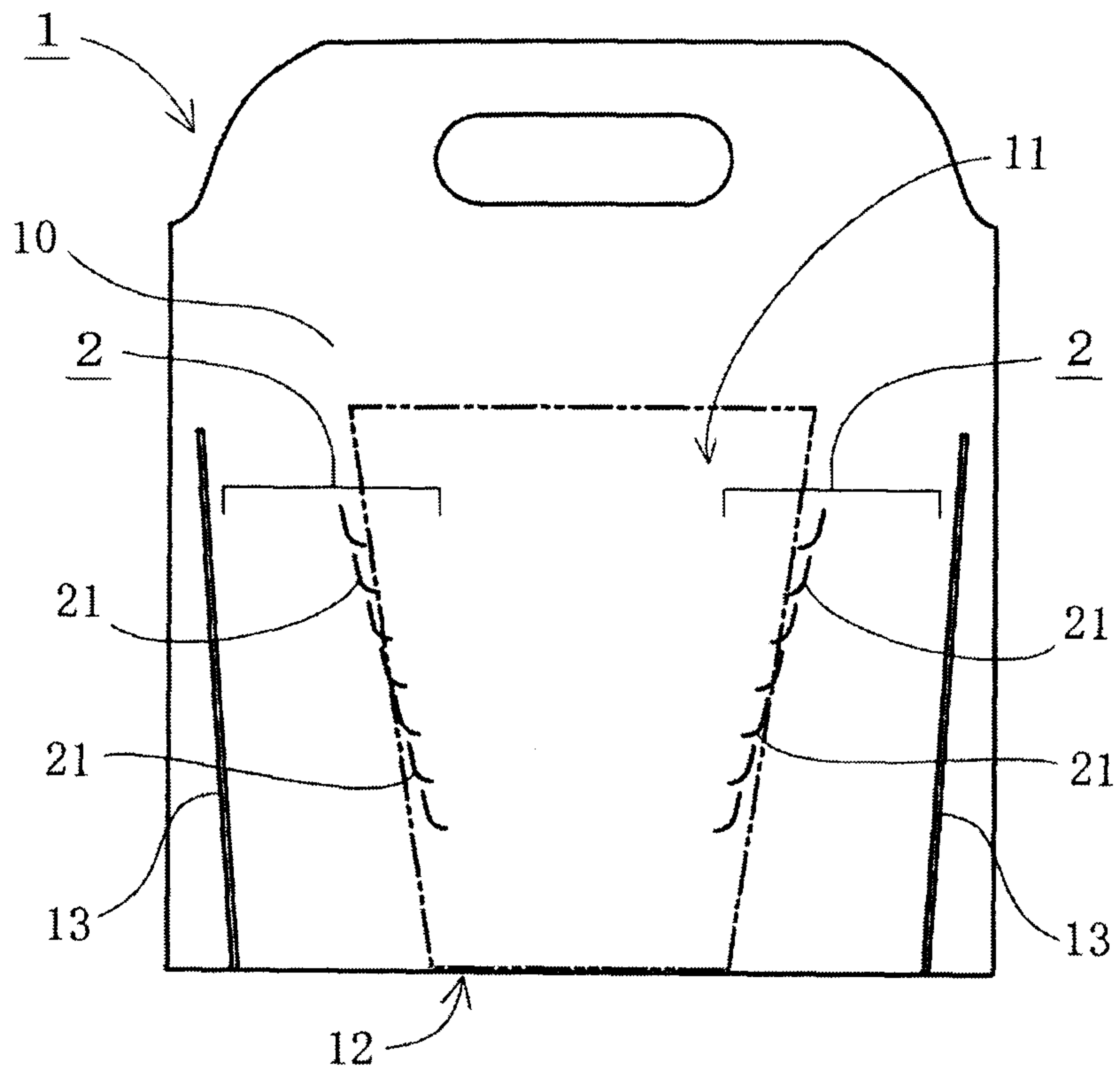

FIG. 14

