

(19) World Intellectual Property
Organization
International Bureau



(43) International Publication Date
18 November 2004 (18.11.2004)

PCT

(10) International Publication Number
WO 2004/099559 A1

- (51) International Patent Classification⁷: **E21B 41/04**
- (21) International Application Number:
PCT/US2004/006660
- (22) International Filing Date: 5 March 2004 (05.03.2004)
- (25) Filing Language: English
- (26) Publication Language: English
- (30) Priority Data:
10/383,154 6 March 2003 (06.03.2003) US
- (71) Applicant (for all designated States except CA, US):
SHELL OIL COMPANY [US/US]; One Shell Plaza, P.O.
Box 2463, Houston, TX 77252-2463 (US).
- (71) Applicant (for CA only): **SHELL CANADA LIMITED**
[CA/CA]; 400 - 4th Avenue S.W., Calgary, Alberta T2P
2H5 (CA).
- (72) Inventors; and
- (75) Inventors/Applicants (for US only): **MCMILLAN, David, Wayne** [US/US]; 1502 Tulsa, Deer Park, TX 77536 (US). **ARMSTRONG, Stephen, Paul** [US/US]; 1719 Prairie Mark Lane, Houston, TX 77077 (US). **WALKER, Dennis, Edward** [US/US]; 1117 East X Street, Deer Park, TX 77563 (US).
- (74) Agent: **MONTALVO, Eugene, R.**; Shell Oil Company, P.O. Box 2463, Houston, TX 77252-2463 (US).
- (81) Designated States (unless otherwise indicated, for every kind of national protection available): AE, AG, AL, AM, AT, AU, AZ, BA, BB, BG, BR, BW, BY, BZ, CA, CH, CN, CO, CR, CU, CZ, DE, DK, DM, DZ, EC, EE, EG, ES, FI, GB, GD, GE, GH, GM, HR, HU, ID, IL, IN, IS, JP, KE, KG, KP, KR, KZ, LC, LK, LR, LS, LT, LU, LV, MA, MD, MG, MK, MN, MW, MX, MZ, NA, NI, NO, NZ, OM, PG, PH, PL, PT, RO, RU, SC, SD, SE, SG, SK, SL, SY, TJ, TM,

[Continued on next page]

(54) Title: APPARATUS AND METHODS FOR REMOTE INSTALLATION OF DEVICES FOR REDUCING DRAG AND VORTEX INDUCED VIBRATION

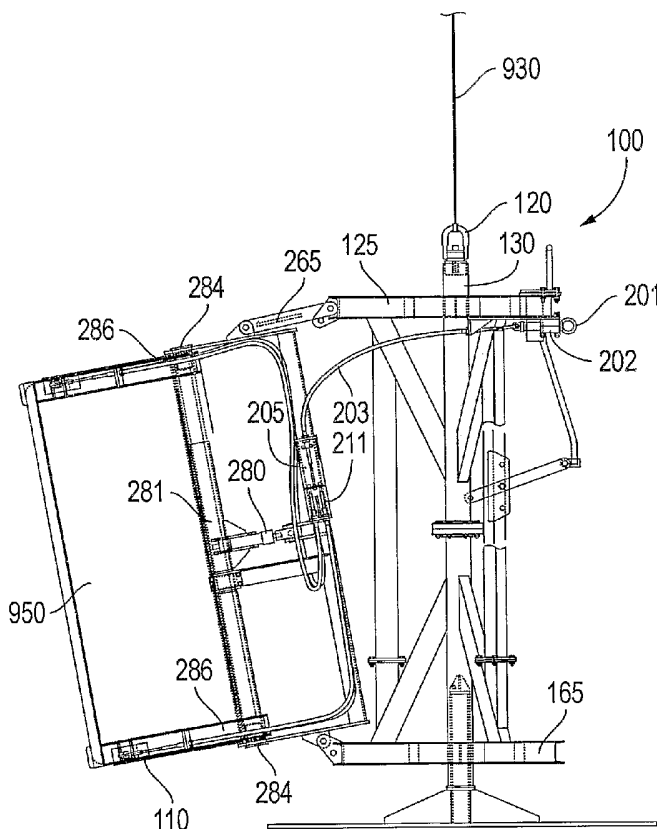

(57) Abstract: Apparatus and methods for remotely installing vortex-induced vibration (VIV) reduction and drag reduction devices on elongated structures in flowing fluid environments. The apparatus is a tool for transporting and installing the devices. The devices installed can include clamshell-shaped strakes, shrouds, fairings, sleeves and flotation modules.

WO 2004/099559 A1



TN, TR, TT, TZ, UA, UG, US, UZ, VC, VN, YU, ZA, ZM, ZW.

TR), OAPI (BF, BJ, CF, CG, CI, CM, GA, GN, GQ, GW, ML, MR, NE, SN, TD, TG).

(84) Designated States (*unless otherwise indicated, for every kind of regional protection available*): ARIPO (BW, GH, GM, KE, LS, MW, MZ, SD, SL, SZ, TZ, UG, ZM, ZW), Eurasian (AM, AZ, BY, KG, KZ, MD, RU, TJ, TM), European (AT, BE, BG, CH, CY, CZ, DE, DK, EE, ES, FI, FR, GB, GR, HU, IE, IT, LU, MC, NL, PL, PT, RO, SE, SI, SK,

Published:

— *with international search report*

For two-letter codes and other abbreviations, refer to the "Guidance Notes on Codes and Abbreviations" appearing at the beginning of each regular issue of the PCT Gazette.

APPARATUS AND METHODS FOR REMOTE INSTALLATION OF DEVICES FOR REDUCING DRAG AND VORTEX INDUCED VIBRATION

RELATED APPLICATION DATA

5 This application is a Continuation-in-part of co-pending U.S. Patent Application No. 10/032,710, filed October 19, 2001.

BACKGROUND OF THE INVENTION

Field of the Invention

10 The present invention relates to apparatus and methods for remotely installing vortex-induced vibration (VIV) and drag reduction devices on structures in flowing fluid environments. In another aspect, the present invention relates to apparatus and methods for installing VIV and drag reduction devices on underwater structures using equipment that can be remotely operated from above the surface of the water. In even another aspect,
15 the present invention relates to apparatus and methods for remotely installing VIV and drag reduction devices on structures in an atmospheric environment using equipment that can be operated from the surface of the ground.

Description of the Related Art

Whenever a bluff body, such as a cylinder, experiences a current in a flowing fluid
20 environment, it is possible for the body to experience vortex-induced vibrations (VIV). These vibrations are caused by oscillating dynamic forces on the surface, which can cause substantial vibrations of the structure, especially if the forcing frequency is at or near a structural natural frequency. The vibrations are largest in the transverse (to flow) direction; however, in-line vibrations can also cause stresses, which are sometimes larger
25 than those in the transverse direction.

Drilling for and/or producing hydrocarbons or the like from subterranean deposits which exist under a body of water exposes underwater drilling and production equipment to water currents and the possibility of VIV. Equipment exposed to VIV includes structures ranging from the smaller tubes of a riser system, anchoring tendons, or lateral
30 pipelines to the larger underwater cylinders of the hull of a minis par or spar floating production system (hereinafter "spar").

Risers are discussed here as a non-exclusive example of an aquatic element subject to VIV. A riser system is used for establishing fluid communication between the surface and the bottom of a water body. The principal purpose of the riser is to provide a fluid

flow path between a drilling vessel and a well bore and to guide a drill string to the well bore.

5 A typical riser system normally consists of one or more fluid-conducting conduits, which extend from the surface to a structure (e.g., wellhead) on the bottom of a water body. For example, in the drilling of a submerged well, a drilling riser usually consists of a main conduit through which the drill string is lowered and through which the drilling mud is circulated from the lower end of the drill string back to the surface. In addition to the main conduit, it is conventional to provide auxiliary conduits, e.g., choke and kill lines, etc., which extend parallel to and are carried by the main conduit.

10 This drilling for and/or producing of hydrocarbons from aquatic, and especially offshore, fields have created many unique engineering challenges. For example, in order to limit the angular deflections of the upper and lower ends of the riser pipe or anchor tendons and to provide required resistance to lateral forces, it is common practice to use apparatus for adding axial tension to the riser pipe string. Further complexities are added
15 when the drilling structure is a floating vessel, as the tensioning apparatus must accommodate considerable heave due to wave action. Still further, the lateral forces due to current drag require some means for resisting them whether the drilling structure is a floating vessel or a platform fixed to the subsurface level.

20 The magnitude of the stresses on the riser pipe, tendons or spars is generally a function of and increases with the velocity of the water current passing these structures and the length of the structure.

It is noted that even moderate velocity currents in flowing fluid environments acting on linear structures can cause stresses. Such moderate or higher currents are readily encountered when drilling for offshore oil and gas at greater depths in the ocean or in an
25 ocean inlet or near a river mouth.

Drilling in ever deeper water depths requires longer riser pipe strings which, because of their increased length and subsequent greater surface area, are subject to greater drag forces which must be resisted by more tension. This is believed to occur as the resistance to lateral forces due to the bending stresses in the riser decreases as the
30 depth of the body of water increases.

Accordingly, the adverse effects of drag forces against a riser or other structure caused by strong and shifting currents in these deeper waters increase and set up stresses

in the structure which can lead to severe fatigue and/or failure of the structure if left unchecked.

There are generally two kinds of current-induced stresses in flowing fluid environments. The first kind of stress is caused by vortex-induced alternating forces that vibrate the structure ("vortex-induced vibrations") in a direction perpendicular to the direction of the current. When fluid flows past the structure, vortices are alternately shed from each side of the structure. This produces a fluctuating force on the structure transverse to the current. If the frequency of this harmonic load is near the resonant frequency of the structure, large vibrations transverse to the current can occur. These vibrations can, depending on the stiffness and the strength of the structure and any welds, lead to unacceptably short fatigue lives. In fact, stresses caused by high current conditions in marine environments have been known to cause structures such as risers to break apart and fall to the ocean floor.

The second type of stress is caused by drag forces, which push the structure in the direction of the current due to the structure's resistance to fluid flow. The drag forces are amplified by vortex-induced vibrations of the structure. For instance, a riser pipe that is vibrating due to vortex shedding will disrupt the flow of water around it more than a stationary riser. This results in more energy transfer from the current to the riser, and hence more drag.

Many types of devices have been developed to reduce vibrations of sub sea structures. Some of these devices used to reduce vibrations caused by vortex shedding from sub sea structures operate by stabilization of the wake. These methods include use of streamlined fairings, wake splitters and flags.

Streamlined or teardrop shaped, fairings that swivel around a structure have been developed that almost eliminate the shedding of vortices. The major drawback to teardrop shaped fairings is the cost of the fairing and the time required to install such fairings. Additionally, the critically required rotation of the fairing around the structure is challenged by long-term operation in the undersea environment. Over time in the harsh marine environment, fairing rotation may either be hindered or stopped altogether. A non-rotating fairing subjected to a crosscurrent may result in vortex shedding that induces greater vibration than the bare structure would incur.

Other devices used to reduce vibrations caused by vortex shedding from sub-sea structures operate by modifying the boundary layer of the flow around the structure to

prevent the correlation of vortex shedding along the length of the structure. Examples of such devices include sleeve-like devices such as helical strakes, shrouds, fairings and substantially cylindrical sleeves.

5 Some VIV and drag reduction devices can be installed on risers and similar structures before those structures are deployed underwater. Alternatively, VIV and drag reduction devices can be installed by divers on structures after those structures are deployed underwater.

10 Use of human divers to install VIV and drag reduction equipment at shallower depths can be cost effective. However, strong currents can also occur at great depths causing VIV and drag of risers and other underwater structures at those greater depths. However, using divers to install VIV and drag reduction equipment at greater depths subjects divers to greater risks and the divers cannot work as long as they can at shallower depths. The fees charged, therefore, by diving contractors are much greater for work at greater depths than for shallower depths. Also, the time required by divers to complete
15 work at greater depths is greater than at shallower depths, both because of the shorter work periods for divers working at great depths and the greater travel time for divers working at greater depths. This greater travel time is caused not only by greater distances between an underwater work site and the water surface, but also by the requirement that divers returning from greater depths ascend slowly to the surface. Slow ascent allows gases,
20 such as nitrogen, dissolved in the diver's blood caused by breathing air at greater depths, to slowly return to a gaseous state without forming bubbles in the diver's blood circulation system. Bubbles formed in the blood of a diver who ascends too rapidly cause the diver to experience the debilitating symptoms of the bends.

25 Elongated structures in wind in the atmosphere can also encounter VIV and drag, comparable to that encountered in aquatic environments. Likewise, elongated structures with excessive VIV and drag forces that extend far above the ground can be difficult, expensive and dangerous to reach by human workers to install VIV and drag reduction devices.

30 However, in spite of the above advancements, there still exists a need in the art for apparatus and methods for installing VIV and drag reduction devices on structures in flowing fluid environments.

There is another need in the art for apparatus and methods for installing VIV and drag reduction devices on structures in flowing fluid environments, which do not suffer from the disadvantages of the prior art apparatus and methods.

5 There is even another need in the art for apparatus and methods for installing VIV and drag reduction equipment on underwater structures without using human divers.

There is still another need in the art for apparatus and methods for installing VIV and drag reduction devices on underwater structures using equipment that can be remotely operated from the surface of the water.

10 There is yet another need in the art for apparatus and methods for installing VIV and drag reduction devices on above-ground devices using equipment that can be operated from the surface of the ground.

There is even still another need in the art for apparatus and methods for installing VIV and drag reduction devices on structures that are not vertical.

15 There is even yet another need in the art for apparatus and methods for installing various lengths of VIV and drag reduction devices.

These and other needs in the art will become apparent to those of skill in the art upon review of this specification, including its drawings and claims.

SUMMARY OF THE INVENTION

20 It is an object of the present invention to provide for apparatus and methods for installing VIV and drag reduction devices on structures in flowing fluid environments.

It is another object of the present invention to provide for apparatus and methods for installing VIV and drag reduction devices on structures in flowing fluid environments, which do not suffer from the disadvantages of the prior art apparatus and methods.

25 It is even another object of the present invention for apparatus and methods for installing VIV and drag reduction devices on underwater structures without using human divers.

It is still an object of the present invention to provide for apparatus and methods for installing VIV and drag reduction devices on underwater structures using equipment that can be remotely operated from the surface of the water.

30 It is yet another object for the present invention to provide for apparatus and methods for installing VIV and drag reduction devices on above-ground structures using equipment that can be operated from the surface of the ground. It is even still another

object of the present invention to provide for apparatus and methods for installing VIV and drag reduction devices on structures that are not vertical.

It is even yet another object of the present invention to provide for apparatus and methods for installing various lengths of VIV and drag reduction devices.

5 These and other objects of the present invention will become apparent to those of skill in the art upon review of this specification, including its drawings and claims.

 According to one embodiment of the present invention, there is provided a tool for remotely installing a clamshell device around an elongated element comprising at least a portion comprising a non-vertically oriented section. The tool comprises a frame having a
10 longitudinal axis; a hydraulic system supported by the frame; and at least one set of two clamps supported by the frame. These clamps are suitable for holding the clamshell device in a non-vertical orientation when the frame is oriented with its longitudinal axis vertical, and suitable for releasing the clamshell device onto the non-vertical section. The clamshell device is selected from the group consisting of vortex-induced vibration
15 reduction devices and drag reduction devices. The set of clamps is connected to the hydraulic system. In a further embodiment of this embodiment, the tool may further include clamps for holding/installing a collar (as described below).

 According to another embodiment of the present invention, there is provided a method of remotely installing a clamshell device having a longitudinal axis, around an
20 elongated element comprising at least a non-vertical section. The method uses a tool having a longitudinal axis, and includes positioning a tool adjacent to the element wherein the tool carries the clamshell device selected from the group consisting of vortex-induced vibration reduction devices and drag reduction devices. The method further includes moving the tool to position the clamshell device around the element, wherein the tool is
25 oriented with its longitudinal axis vertical, and the clamshell device is oriented with its longitudinal axis non-vertical. The method even further includes operating the tool to close the clamshell device around the element. Finally, the method includes securing the device in position around the element.

 According to even another embodiment of the present invention, there is provided
30 a tool for remotely installing a clamshell device and a collar around an element. The tool generally includes a frame and a hydraulic system supported by the frame. The tool further includes at least one set of two clamshell-holding clamps supported by the frame, the set suitable for holding the clamshell device and releasing the clamshell device,

wherein the clamshell device is selected from the group consisting of vortex-induced vibration reduction devices and drag reduction devices. The tool also includes at least one set of two collar-holding clamps supported by the frame, the set suitable for holding the collar and releasing the collar. The set of collar-holding clamps and the set of clamshell-
 5 holding clamps are connected to the hydraulic system, and said claims may be independently or dependently operated. That is to say, the collar-holding clamps and the clamshell-holding clamps may be operated to open/close simultaneously, or at different times. In a further embodiment of the present invention, these collar-holding clamps and the clamshell-holding clamps are suitable for holding the clamshell device and collar in a
 10 non-vertical orientation when the frame is oriented with its longitudinal axis vertical, and suitable for releasing the clamshell device onto the non-vertical section.

According to still another embodiment of the present invention, there is provided a method of remotely installing a clamshell device and a collar around a non-vertical element. The method generally includes positioning a tool adjacent to the element,
 15 wherein the tool carries the clamshell device and the collar, preferable with the clamshell device and collar positioned vertically, one above the other. The clamshell device is selected from the group consisting of vortex-induced vibration reduction devices and drag reduction devices. The method further includes moving the tool to position the clamshell device and collar around the element. The method even further includes operating the tool
 20 to close the clamshell device and collar around the element. The method still further includes securing the device and collar in position around the element.

These and other embodiments of the present invention will become apparent to those of skill in the art upon review of this specification, including its drawings and claims.

25 **BRIEF DESCRIPTION OF THE DRAWINGS**

FIG. 1 is a top view of Diverless Suppression Deployment Tool (DSDT) 100, showing carousel clamps 110.

FIG. 2 is a side elevational view of DSDT 100 showing tubular framework supports 150 and 155.

30 FIG. 3 is a side elevational view of DSDT 100 in a shortened or retracted position.

FIG. 4 is a side elevational view of DSDT 100 in an extended position.

FIG. 5 is an illustration of a helical strake with nipples.

FIG. 6 is an illustration of carousel clamp 600 in its closed position and designed for holding a fairing.

FIG. 7 is an illustration of carousel clamp 110 in its open position and designed to hold such devices as a helical strake.

5 FIG. 8A is a top view of DSDT 100 with clamp 110A open and 110B closed.

FIG. 8B is a detailed illustration of nipple 820 attached to strake 500.

FIG. 9 is an illustration of remotely operated vehicle (ROV) 900 manipulating Diverless Suppression Deployment Tool (DSDT) 100.

10 FIG. 10 is an illustration of a top view of ROV 900 manipulating DSDT 100 to encircle fairing 950.

FIG. 11 is an illustration of a top view of ROV 900 manipulating fairing 950 to close around riser 810.

FIG. 12 is an alternative embodiment showing nipple 710 positioned on arm 740, and received into passage 713 in the strake.

15 FIG. 13 is a top view of alternative clamp 600 with a fairing installed.

FIG. 14 shows an equivalent view to FIG. 1 showing a DSDT 100, except that alternative clamp 600 of FIG. 13 has replaced collar 110.

20 FIGS. 15-24 shown a sequence of installing a collar onto a riser, focusing on a top view of one alternative clamp 600 (as shown in FIG. 13) of a DSDT 100, specifically, FIG. 15 shows a collar 22 being inserted thereto; FIG. 16 shows a collar half rotated into fixed insert; FIG. 17 shows an opposite half of the collar rotated into moving insert; FIG. 18 shows the DSDT being moved onto the pipe 23; FIG. 19 shows a further advance of the DSDT being moved onto the pipe; FIG. 20 shows an even further advance of the DSDT being moved onto the pipe; FIG. 21 shows the cylinder closing the fairing clamp as the
25 collar grip drives the collar closed; FIG. 22 shows a further advance of the cylinder closing the fairing clamp as the collar grip drives the collar closed; FIG. 23 shows an even further advance of the cylinder closing the fairing clamp as the collar grip drives the collar closed; FIG. 24 shows the DSDT moving away from the riser pipe with collar and fairing installed.

30 FIGS. 25A, 25B and 25C and 27A and 27B show a fairing 35 having a locking mechanism 33.

FIGS. 26A, 26B, 26C and 26D are a sequence showing the locking of locking mechanism 33.

FIGs. 28, 31 and 33 are top views of an alternative embodiment of DSDT 100 showing three clamps 110, top plate 125, and brace 130.

FIGs. 29, 30 and 32 are side views of a portion of DSDT 100 of FIGs. 28, 31 and 33, respectively.

5 FIGs. 34 and 35 show DSDT 100 having fairing 950 in the vertical position (FIG. 34) and in on off vertical position (FIG. 35) due to the insertion of extension member 265.

FIGs. 36, 37 and 38 show and isolated view of collar-holding clamps 500, respectively showing a side view, top view with clamps 500 open, and top view with clamps 500 closed/.

10 DETAILED DESCRIPTION OF THE INVENTION

Referring first to FIG. 1, there is illustrated a top view of Diverless Suppression Deployment Tool (DSDT) 100, which is designed to be remotely operated without the use of human divers in the installation of clamshell-shaped strakes, shrouds, fairings, regular and ultra-smooth sleeves and other VIV and drag reduction equipment underwater to such structures, including but not limited to, oil and gas drilling or production risers, steel
15 catenary risers, and anchor tendons. Slight modifications in DSDT 100 might be required for each particular type of VIV and drag reduction equipment to be installed. These modifications generally will involve modification to clamps 110 so that they can physically accommodate the various types of VIV and drag reduction equipment to be
20 installed.

For example, the embodiment as shown in FIGs. 1 and 2 is more conducive for the installation of helical strakes.

Ultra-smooth sleeves are described in United States Patent Application Serial No. 09/625,893 filed July 26, 2000 by Allen et al., which is incorporated herein by reference.

25 Shown in this embodiment of FIG. 1 are six carousel clamps 110 connected to top plate 125 of DSDT 100. Clamps 110 are designed to hold such VIV and drag reduction structures such as a strake, sleeve or other substantially cylindrical device. Also shown is top plate 125 attached to brace 130, which in this embodiment comprises six lateral braces, but may comprise an unlimited number of lateral braces. Top plate 125 defines
30 hydraulics port opening 135, which provides access for a valve and hydraulic control system lines through DSDT 100 from water surface 910, illustrated in FIG. 9.

Referring now to FIG. 2, there is illustrated a lateral view of DSDT 100 of FIG. 1, showing six carousel clamps 110 connected to top plate 125. Carousel clamps 110 are

designed to hold structures similar to a strake, sleeve or other substantially cylindrical device. It should be noted that an unlimited number of clamps may be connected to the top plate 125 of DSDT 100, so long as that number is suitable for completing a task in a flowing fluid environment. The number of clamps may be about two, preferably about 5 four, more preferably about six, even more preferably about eight, still more preferably about ten, yet more preferably about twelve. A similar range of numbers of clamps may also be connected to bottom plate 165 of DSDT 100. For example, embodiments of DSDT 100 shown in FIGs. 28, 31 and 33 have three clamps 110 on top plate 125 and bottom plate 165. Specifically, FIGs. 28, 31 and 33 are top views of an alternative 10 embodiment of DSDT 100 showing three clamps 110, top plate 125, and brace 130, with FIGs. 29, 30 and 32 being their respective side views.

FIG. 2 also illustrates brace 130 with connector 120 designed to attach to a line for lowering and raising DSDT 100. Also shown are six ball valves 115 each used for hydraulically controlling one pair of clamps 110 oriented in a vertical line, between one 15 clamp 110 connected to top plate 125 and another clamp 110 connected to bottom plate 165. Shown also is rod assembly 140 connected to top plate 125, wherein assembly 140 serves as a handle for manipulation of DSDT 100 by a remotely operated vehicle.

Also shown in FIG. 2 is first tubular brace 150, comprised of vertical and cross pieces which are interconnected with second tubular brace 155, which is in turn connected 20 to bottom plate 165. In addition, first central tube 170 is connected to top plate 125 and to second central tube 175, which in turn is connected to bottom plate 165. Braces 150 and 155, central tubes 170 and 175, and plates 125 and 165 comprise a framework.

Shown in FIG. 2 also are hydraulic cylinders 160, each of which connects one clamp 110 with either top plate 125 or bottom plate 165. A tubular hydraulic system (not 25 shown), containing a hydraulic fluid, extends from hydraulics port 135 at least partially through tubular braces 150 and 155 and central tubes 170 and 175 to hydraulic cylinders 160. Hydraulic cylinders 160 are supplied with hydraulic fluid and hydraulic fluid pressure modulations to open and close clamps 110 which can hold clamshell devices such as strakes, shrouds, fairings or sleeves and close them around a structure.

30 Referring now to FIG. 3, there is illustrated a side view of DSDT 100 in a retracted position that minimizes the size of DSDT 100 for storage and handling. Shown are first tubular brace 150, first central tube 170, rod assembly 140, hydraulic cylinder 160, and bottom brace 310.

Referring next to FIG. 4, there is illustrated an extended position for DSDT 100, showing first brace 150, first central tube 170, second brace 155, and second central tube 175. Second brace 155 and second central tube 175 are capable of moving into and partially out of first brace 150 and first central tube 175, respectively. An extended
5 position for DSDT 100 allows it to carry and install longer strakes, shrouds, fairings or other sleeve-like structures than would be possible with the retracted position of DSDT 100, shown in FIG. 3.

An alternative to the use of telescoping tubes 170 and 175, and braces 150 and 155, for adjusting DSDT 100 to accommodate various sizes of strakes, shrouds, fairings or
10 other sleeve-like structures is shown in FIG. 30. Specifically, in FIG. 30, there is shown spool or extension member 156 positioned between flange members 158 and 159. Such spool or extension members may be utilized throughout DSDT 100 to allow adjusting to accommodate various sizes of strakes, shrouds, fairings or other sleeve-like structures. Of course, a combination of telescoping and spool members may be utilized as desired.

Referring next to FIG. 5, there is illustrated a side view of clamshell helical strake
15 500, with tubular body 510 and fins 520 projecting from tubular body 510. Any number of apparatus and methods could be utilized to anchor strake 500 to carousel clamp 110 while strake 500 is being carried and installed by DSDT 100. As a non-limiting example, nipples 540 are shown projecting out of each end of the exterior of strake 500 and will
20 mate with a matching recess in clamp 110, while hinge/clamps 530 are shown in their closed position on both sides of strake 500. Hinge/clamps 530 are normally closed on both sides of strake 500 only during shipping or after strake 500 has been fastened around a structure such as a riser, or horizontal or catenary pipe. At other times, hinge/clamps 530 are closed on one side of strake 500 and open on the other side. With closed
25 hinge/clamps 530 on just one side of strake 500, hinge/clamps 530 serve as hinges allowing clamshell strake 500 to open like a clamshell on the side of strake 500 opposite the closed hinge/clamps 530.

Of course, the nipples and recesses could be reversed, that is, the nipples could be on clamp 110, and the mating recesses on strake 500 as is shown in an alternative
30 embodiment in FIG. 7, and as shown connected in FIG. 12 (with FIGs. 7 and 12 discussed in more detail below).

Referring now to FIG. 6, there is illustrated one embodiment of a clamp designed to hold a teardrop shaped fairing both in an open and a closed position (another embodiment is discussed below).

5 Carousel clamp 600, shown in its closed position, is comprised primarily of two arms, first arm 630 and second arm 640. Shown are nipples 610 in arms 630 and 640. These nipples 610 are designed to pass through an opening on a fairing and temporarily anchor a fairing to an interior face of the clamp 600. Attachment 620 is designed to attach to hydraulic cylinder 160, which cylinder 160, when activated, can open and close clamp 600.

10 In some instances, depending upon the circumference of the fairing, and flexibility of the materials, the essentially circular shape of the back of closed clamp 600 as shown in FIG. 6 is likely to cause problems handling a fairing, as the fairing will bow back and strike clamp 600, and will either be unstable or prone to coming loose.

A preferred alternative embodiment of clamp 600 is shown in FIG. 13, showing a top view of alternative clamp 600 with a fairing installed. For alternative clamp 600, its arms 630 and 640 are provided different rotation axis, which operate to provide space for a closed fairing to bow backward. In more detail, alternative clamp 600 further includes fairing retainer mechanism 631 and 641 on their respective arms 630 and 640. Also shown are fixed collar grip 632, collar index 633, closer cylinder 644, stiffener 643, and collar closer grip 642.

Referring additionally to FIG. 14, there is shown an equivalent view to FIG. 1 showing a DSDT 100, except that alternative clamp 600 of FIG. 13 has replaced collar 110.

Referring next to FIG. 7, there is illustrated carousel clamp 110 with first arm 730 and second arm 740. Clamp 110 is designed to hold strake 500. Shown inserted into arms 730 and 740 are nipples 710 which are designed to penetrate an opening on strake 500 and temporarily anchor strake 500 to clamp 110. Attachment 720 in arm 740 is designed to attach to hydraulic cylinder 160. Hydraulic cylinder 160, when activated, can open and close clamp 110.

Referring now to FIG. 8A, there is illustrated a top view of DSDT 100 with carousel clamps 110A and 110B at two of six possible positions. Clamp 110A is open and has attached to it strake 500 in an open position. Fin 520 of strake 500 is shown in cross-section. Also shown is a top or cross-sectional view of riser 810. Manipulation of DSDT 100 positions strake 500 around an underwater structure such as riser 810. After strake

500 is positioned around a structure such as riser 810, clamp 110 is closed, thereby closing strake 500 closely around riser 810. With strake 500 closed, hinge/clamp halves 532 and 534 are positioned adjacent to and overlapping each other. Closed strake 500 is shown attached to clamp 110B. Closed hinge/clamps 530, comprised of hinge/clamp halves 532 and 534 are positioned on two sides of strake 500. One hinge/clamp 530 acted as a hinge until strake 500 was closed. The remaining hinge/clamp 530 can be locked closed by inserting a captive pin into it after it is closed.

Referring next to FIG. 8B, which is a detail of clamp 110A in FIG. 8A, there is illustrated nipple 820 attached to strake 500 inserted inside of rubber padding 830 held by coupling 850 (again, any suitable type of connection can be used in place of the nipple/recess, and the nipple/recess can be reversed). Coupling 850 is encircled by space 860, which allows limited movement of coupling 850 inside of clamp 110A. Coupling can rotate to a limited extent about pivot point 840.

Referring now to FIG. 9, there is illustrated remotely operated vehicle (ROV) 900 manipulating, via arm 920, DSDT 100. DSDT 100 is suspended by line 930 from the vicinity of water's surface 910. Line 930 carries hydraulic lines 935 (not shown) that extend from a vessel or production platform (not shown) into DSDT 100 for the purpose of operating hydraulic cylinders 160 to open and close clamps such as clamps 110, which can carry sleeve-like devices. DSDT 100 is shown carrying fairing 950 to be placed around riser 810. Fairing 950 is to be placed above previously positioned fairing 955.

FIG. 9 can further be used to illustrate an overview of DSDT 100 deployment where the steps involve DSDT 100 being positioned adjacent to the riser on which the strakes, shrouds, fairings or other sleeve-like devices, including flotation modules, will be installed. The most effective way to control the uppermost position of sleeves around riser 810 is to attach one collar 940 above the area where the DSDT 100 is to be lowered.

Strakes, shrouds, fairings, or other sleeve-like devices, will stack up on each other if they have low buoyancy and sink to another collar 940 placed around riser 810 at a desired lower stop point. DSDT 100 can be lowered to the bottom position and work can commence from the bottom-most position upward. When the DSDT 100 is at the proper position, the first strake or fairing section can be opened by retracting hydraulic cylinder 160. ROV 900 can then assist by gently tugging the DSDT 100 over to engage the strake or fairing around the riser. DSDT 100 should be about a foot above the lower collar 940. Once the clamshell device, such as strake, shroud, fairing, or sleeve has engaged the riser,

the hydraulic cylinder is extended. This closes the clamshell around the riser. At this time ROV 900 can visually check to see if the alignment looks good. If so, ROV 900 strokes a captive pin 956 downward, locking the strake, fairing or clamshell sleeve around the riser. Carousel arms, such as 630 and 640 are then disengaged by retracting the hydraulic
5 cylinders. DSDT 100 will then move away from the riser, and the first strake, fairing or clamshell sleeve section will drop down, coming to rest on the lower collar 940. DSDT 100 is then moved up until it is about a foot above the first of the sleeve-like devices.

The installation continues until all six sleeve-like devices are installed. DSDT 100 is then retrieved and six more sections are installed. The installation is not extremely fast.
10 It should be kept in mind, however, that in this illustrated embodiment only platform resources are being used, so the job can be done in times of inactivity and calm sea states. Of course, other embodiments are envisioned in which auxiliary resources (i.e., independent vessels and/or other platforms) may be utilized.

Referring now to FIG. 10, there is illustrated a top view of ROV 900 manipulating
15 with arm 920 DSDT 100 to encircle riser 810 with fairing 950. Only one of 6 positions around DSDT 100 is shown as occupied with a carousel clamp, such as here clamp 640 for installation of fairings. However, all six position maybe occupied by carousel clamps. Note that hydraulic cylinder 160 is in a retracted position. Shown are connecting ends 952 and 954 of fairing 950.

Referring to FIG. 11, there is illustrated a fastening step occurring after the
20 encircling step shown in FIG. 10. FIG. 11 illustrates a top view of ROV 900 closing together ends 952 and 954 with arm 920 so that the ends can be connected to each other. Note that hydraulic cylinder 160 is extended forcing clamp 600 to close, thereby closing fairing 950. Captive pin 956 can be stroked down by ROV 900 to lock the fairing in
25 place.

Referring now to FIGS. 15-24, there is shown a sequence of installing a collar onto
a riser. This sequence focuses on a top view of one alternative clamp 600 (as shown in FIG. 13, with the reference numbers of FIG. 13 applying to these FIGS. 15-24) of a DSDT. Specifically, FIG. 15 shows a collar 22 being inserted thereto; FIG. 16 shows a collar half
30 rotated into fixed insert; FIG. 17 shows an opposite half of the collar rotated into moving insert; FIG. 18 shows the DSDT being moved onto the pipe 23; FIG. 19 shows a further advance of the DSDT being moved onto the pipe; FIG. 20 shows an even further advance of the DSDT being moved onto the pipe; FIG. 21 shows the cylinder closing the fairing

clamp as the collar grip drives the collar closed; FIG. 22 shows a further advance of the cylinder closing the fairing clamp as the collar grip drives the collar closed; FIG. 23 shows an even further advance of the cylinder closing the fairing clamp as the collar grip drives the collar closed; FIG. 24 shows the DSDT moving away from the riser pipe with collar and fairing installed.

The various pairs of clamps 110 are shown above as being engaged by independent hydraulic mechanisms 160, a design which requires that the various hydraulic mechanisms 160 operate in unison to open/close the top and bottom clamps 110 together. An alternative mechanism is presented in FIGs. 28 and 29, in which a centrally positioned hydraulic cylinder 280 engages rod 281 having rod ends 284 in mechanical contact with lever arms 286 which when operated, open/close the arms of clamps 110.

As another alternative embodiment, clamps 110 may be provided with a cable release mechanism for releasing the strakes, shrouds, fairings or other sleeve-like structures held by clamps 110. Referring to FIGs. 28, 29, 32 and 33, there is shown cable release system 200 in which a pull cable 205 engages 4 cables 211 to release pins 218 thereby releasing the strake, shroud, fairing or other sleeve-like structure. Specifically, a pull ring 201 slidably positioned in anchor 202, is provided that when pulled retracts cable 205 residing within cable run 203. In the underwater environment, pull ring 201 is provided with a float that can easily grabbed by a robot arm. From block 209, four cables 111 extend through cable runs 207, 208, 214 and 215 to fairing (shroud or strake) pins 218. Retracting cable 205 engages cables 111 thru block 209 thus releasing release pins 218. Of course, release pins 218 may be engaged by any suitable mechanism, such as a hydraulic mechanism.

In some installations, it is necessary to install a fairing (shroud or strake) onto a member that is not running vertically. In such an instance, it is very difficult to maneuver DSDT 100 into the proper position and quickly install the fairing (shroud or strake). It would be advantageous if the fairing could be positioned at the proper orientation, that is, not vertical. while DSDT 100 is suspended from line 930.

Referring now to FIG. 34, there is shown fairing 950 being held in the vertical position by DSDT 100 suspended by line 930. Installing fairing 950 onto an off-vertical member requires orienting DSTS at an off-vertical position-something somewhat difficult to accomplish.

In an alternative embodiment, clamps 110 may be positioned to hold fairing 950 in an off-vertical position, even while DSDT 100 is suspended from line 930, with the main body of DSDT positioned with its longitudinal axis vertical and aligned with suspension line 930.

5 Referring now to FIG. 35, extension member 265 serves to position upper clamp 110 further away from top member 125 than bottom claim 110 is from bottom member 165. The result is that fairing 950 is positioned off vertical and may be positioned onto an angled riser quickly without any repositioning of DSDT 100. Member 265 is illustrated in
10 FIG. 35 as being a removable member that can be replaced by other members 265 of various lengths to accommodate various angles. Of course, it should be understood that member 265 could be replaced by a telescoping, retracting, hydraulically moveable, or otherwise adjustable member 265 that can be adjusted to various lengths.

Many times, it is desirable to install a collar along with a fairing (sometimes a collar is provided between each fairing, or every other fairing, or every third fairing, or as
15 desired). Referring now to FIGS. 32 and 33, there is shown clamps 500 positioned above clamps 110. Isolated side view, top view with clamps 500 open, and top view with clamps 500 closed, are shown in FIGS. 36, 37 and 38. These clamps 500 serve to position a collar onto the member at the same time that a fair (shroud or strake) is being installed. Similar to clamps 110, collar clamps 500 are operated by hydraulic mechanism 503, and are held
20 closed by lock 505.

Although any fairing is believed to be suitable for use in the present invention, preferably a fairing utilized in the present invention will comprise a locking mechanism that will allow the DSDT to lock the fairing around a riser pipe upon installation. Generally, the ends of the fairing will be outfitted with a mating locking mechanism that
25 locks upon contact. A non-limiting example of such a locking mechanism 33 is shown in FIGS. 25A-25C and 27A-27B as part of fairing 35. A sequence showing the locking of locking mechanism 33 is shown in FIGS. 26A thru 26D.

While the Diverless Suppression Deployment Tool 100 has been described as being used in aquatic environments, that embodiment or another embodiment of the
30 present invention may also be used for installing VIV and drag reduction devices on elongated structures in atmospheric environments with the use of an apparatus such as a crane.

While the illustrative embodiments of the invention have been described with particularity, it will be understood that various other modifications will be apparent to and can be readily made by those skilled in the art without departing from the spirit and scope of the invention. Accordingly, it is not intended that the scope of the claims appended
5 hereto be limited to the examples and descriptions set forth herein but rather that the claims be construed as encompassing all the features of patentable novelty which reside in the present invention, including all features which would be treated as equivalents thereof by those skilled in the art to which this invention pertains.

WE CLAIM:

1. A tool for remotely installing a clamshell device around an elongated element comprising at least a portion comprising a non-vertically oriented section, the tool comprising:
 - 5 (a) a frame having a longitudinal axis;
 - (b) a hydraulic system supported by the frame; and
 - (c) at least one set of two clamps supported by the frame, the set suitable for holding the clamshell device in a non-vertical orientation when the frame is oriented with its longitudinal axis vertical, and suitable for releasing the clamshell device onto the non-
10 vertical section, wherein the clamshell device is selected from the group consisting of vortex-induced vibration reduction devices and drag reduction devices,
wherein the set of clamps is connected to the hydraulic system.
2. The tool of claim 1,
15 wherein the frame has a top and a bottom,
wherein the set of clamps is comprised of a first clamp and a second clamp, and
wherein the first clamp is supported by the top of the frame and the second clamp is supported by the bottom of the frame.
3. The tool of claim 1, wherein there are at least two
20 sets of clamps.
4. The tool of claim 1, wherein the set of clamps holds the clamshell device.
- 25 5. The tool of claim 2, wherein the first clamp and the second clamp each comprise at least one nipple for anchoring the clamshell device to the set of clamps.
6. The tool of claim 3, wherein there are at least two clamshell devices, and
30 wherein each of the at least two sets of clamps holds one clamshell device.
7. The tool of claim 1, wherein the length of the frame may be adjusted by the addition of sections of extension members.

8. A method of remotely installing a clamshell device having a longitudinal axis, around an elongated element comprising at least a non-vertical section, using a tool having a longitudinal axis, the method comprising:
- 5 (a) positioning a tool adjacent to the element wherein the tool carries the clamshell device selected from the group consisting of vortex-induced vibration reduction devices and drag reduction devices;
- (b) moving the tool to position the clamshell device around the element, wherein the tool is oriented with its longitudinal axis vertical, and the clamshell device is oriented with its longitudinal axis non-vertical;
- 10 (c) operating the tool to close the clamshell device around the element;
- (d) securing the device in position around the element.
9. The method of claim 8, wherein the tool of step (a) carries at least two clamshell devices, the method further comprising:
- 15 (e) repeating steps (a), (b), (c), and (d).
10. The method of claim 8, wherein the clamshell device installed is an ultra-smooth sleeve.
- 20 11. The method of claim 8, wherein the clamshell device installed is a flotation module.
12. A tool for remotely installing a clamshell device and a collar around an element, the tool comprising:
- 25 (a) a frame;
- (b) a hydraulic system supported by the frame; and
- (c) at least one set of two clamshell-holding clamps supported by the frame, the set suitable for holding the clamshell device and releasing the clamshell device, wherein the clamshell device is selected from the group consisting of vortex-induced
- 30 vibration reduction devices and drag reduction devices;
- (d) at least one set of two collar-holding clamps supported by the frame, the set suitable for holding the collar and releasing the collar; and

wherein the set of collar-holding clamps and the set of clamshell holding clamps are connected to the hydraulic system, and said claims may be independently or dependently operated.

- 5 13. The tool of claim 12,
wherein the frame has a top and a bottom,
wherein the set of clamshell-holding clamps is comprised of a first clamp and a
second clamp, and
wherein the first clamp is supported by the top of the frame and the second clamp
10 is supported by the bottom of the frame.
14. The tool of claim 12, wherein there are at least two sets of clamshell holding
clamps.
- 15 15. The tool of claim 12, wherein the set of clamshell holding clamps holds the
clamshell device.
16. The tool of claim 14, wherein the first clamp and the second clamp of the
clamshell-holding clamp, each comprise at least one nipple for anchoring the clamshell
20 device to the set of clamps.
17. The tool of claim 14, wherein there are at least two clamshell devices, and
wherein each of the at least two sets of clamshell- holding clamps holds one
clamshell device.
- 25 18. The tool of claim 12, wherein the length of the frame may be adjusted by the
addition of sections of extension members.
19. A method of remotely installing a clamshell device and a collar around an non-
30 vertical element, the method comprising:
(a) positioning a tool adjacent to the element,

wherein the tool carries the clamshell device and the collar, wherein the clamshell device is selected from the group consisting of vortex-induced vibration reduction devices and drag reduction devices;

- 5 (b) moving the tool to position the clamshell device and collar around the element;
- (c) operating the tool to close the clamshell device and collar around the element; and
- (d) securing the device and collar in position around the element.

10 20. The method of claim 19, wherein the tool of step (a) carries at least two clamshell devices, the method further comprising:

- (e) repeating steps (a), (b), (c), and (d).

15 21. The method of claim 19, wherein the clamshell device installed is an ultra-smooth sleeve.

22. The method of claim 19, wherein the clamshell device installed is a flotation module.

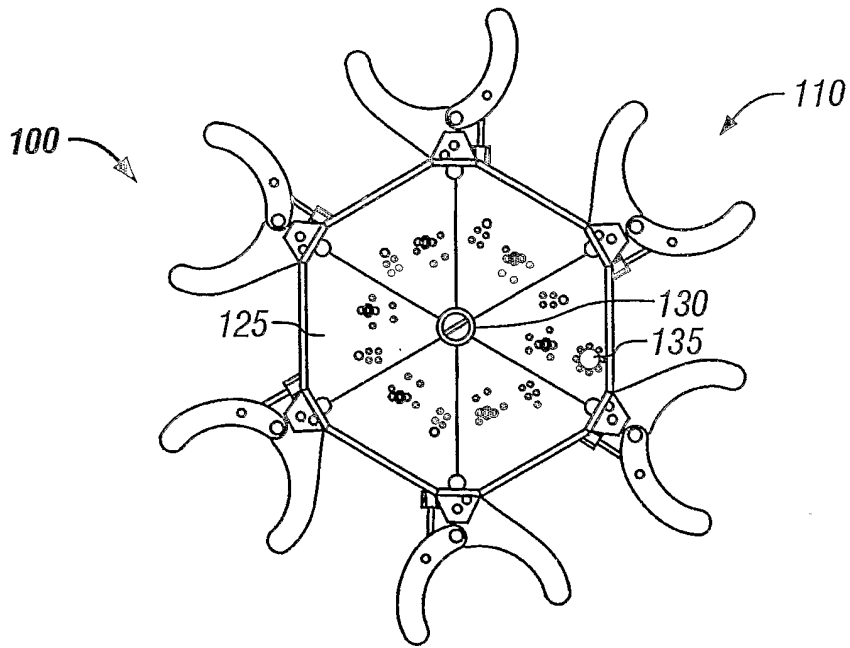

FIG. 1

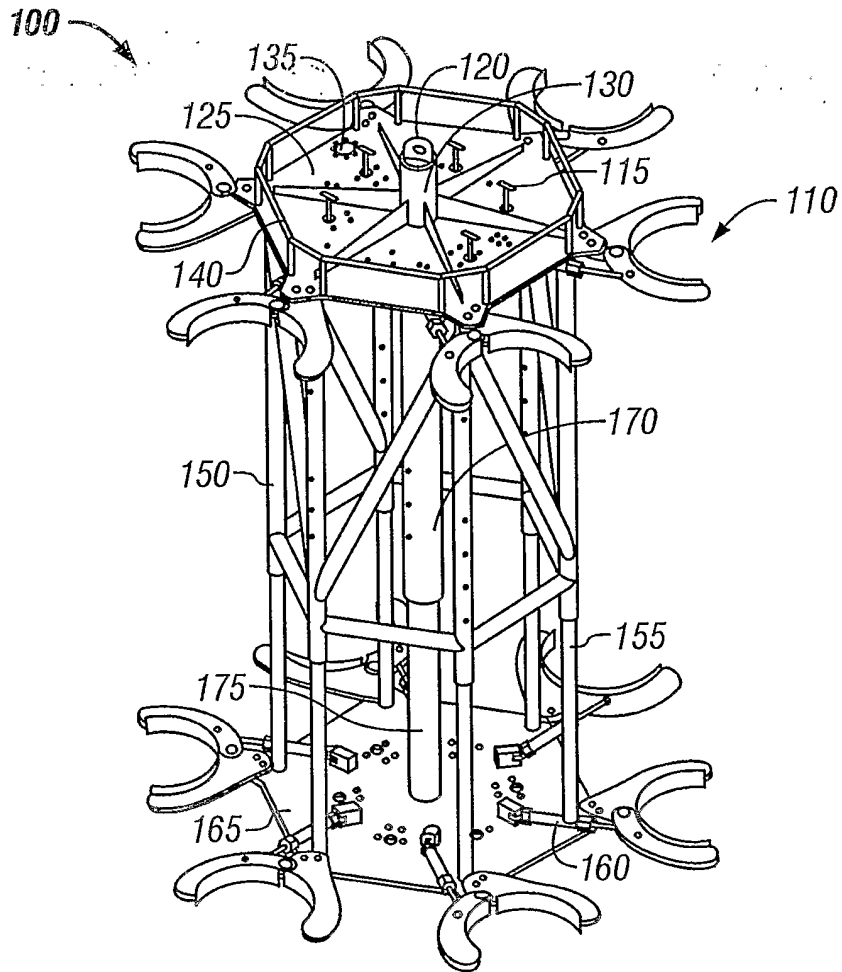

FIG. 2

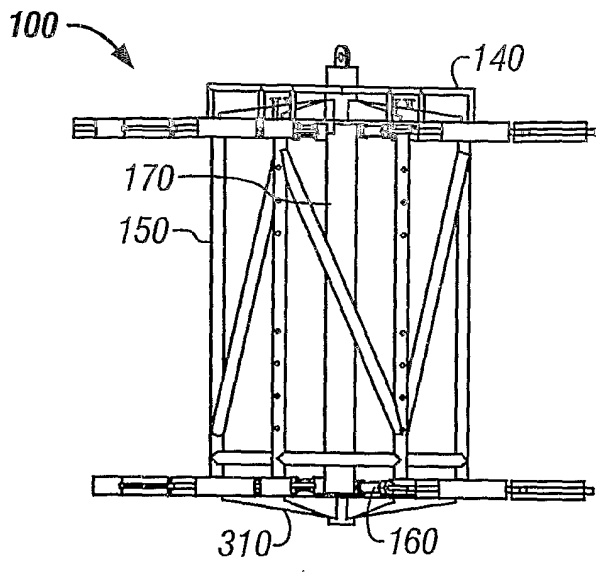

FIG. 3

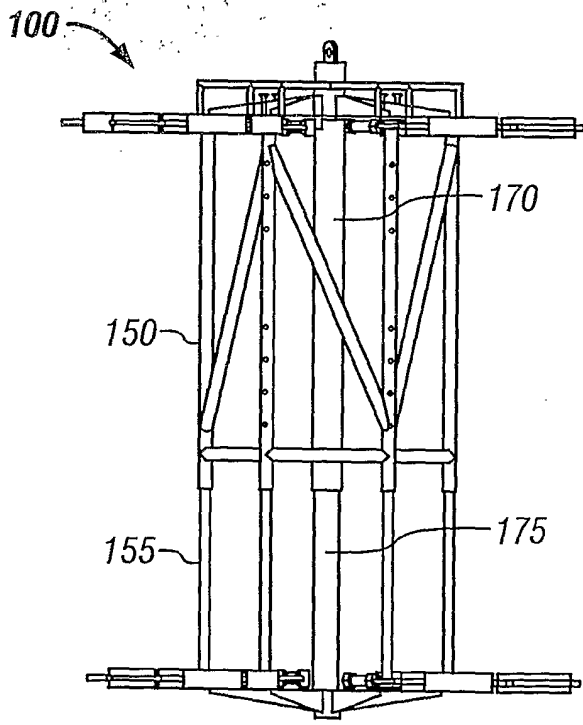

FIG. 4

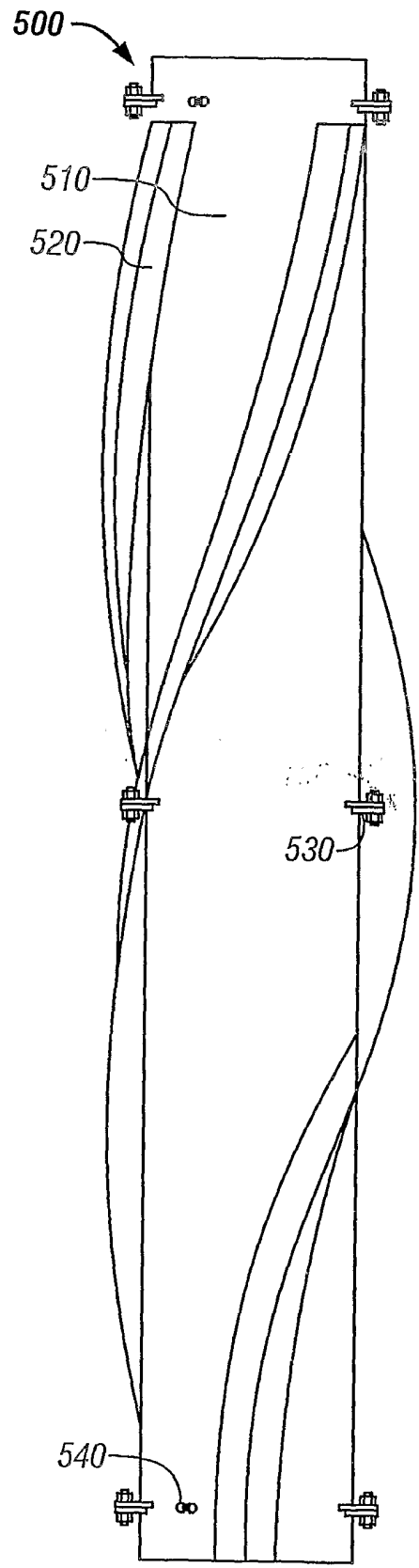

FIG. 5

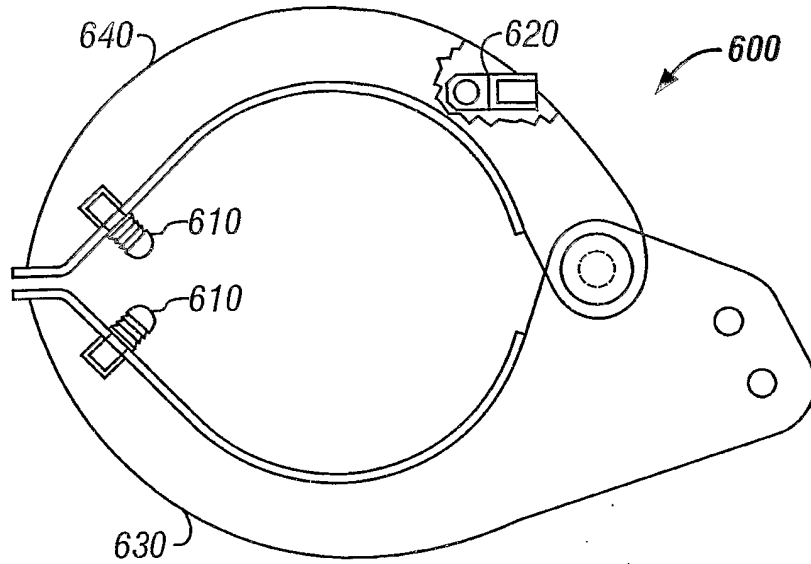

FIG. 6

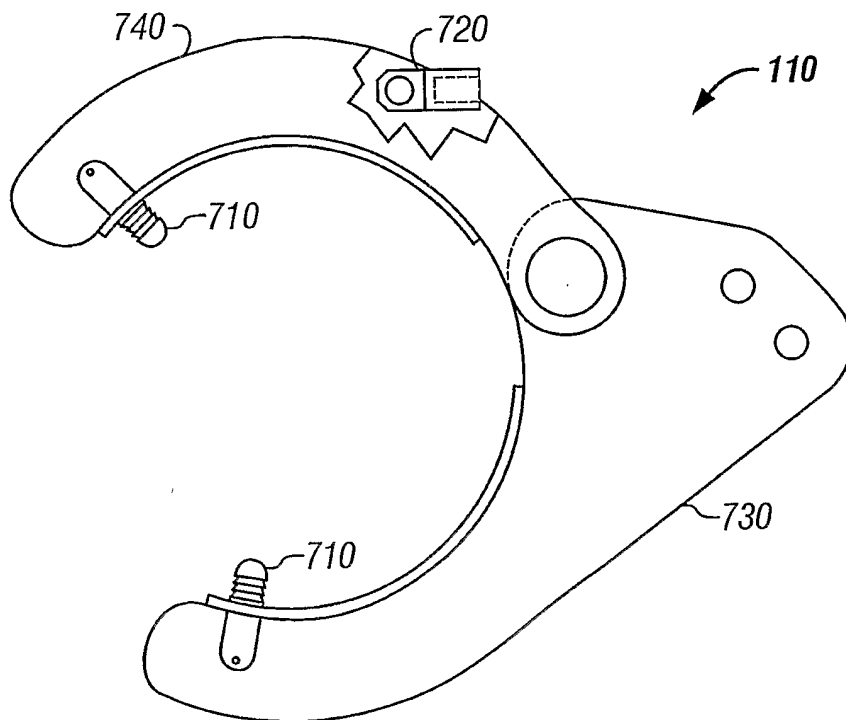

FIG. 7

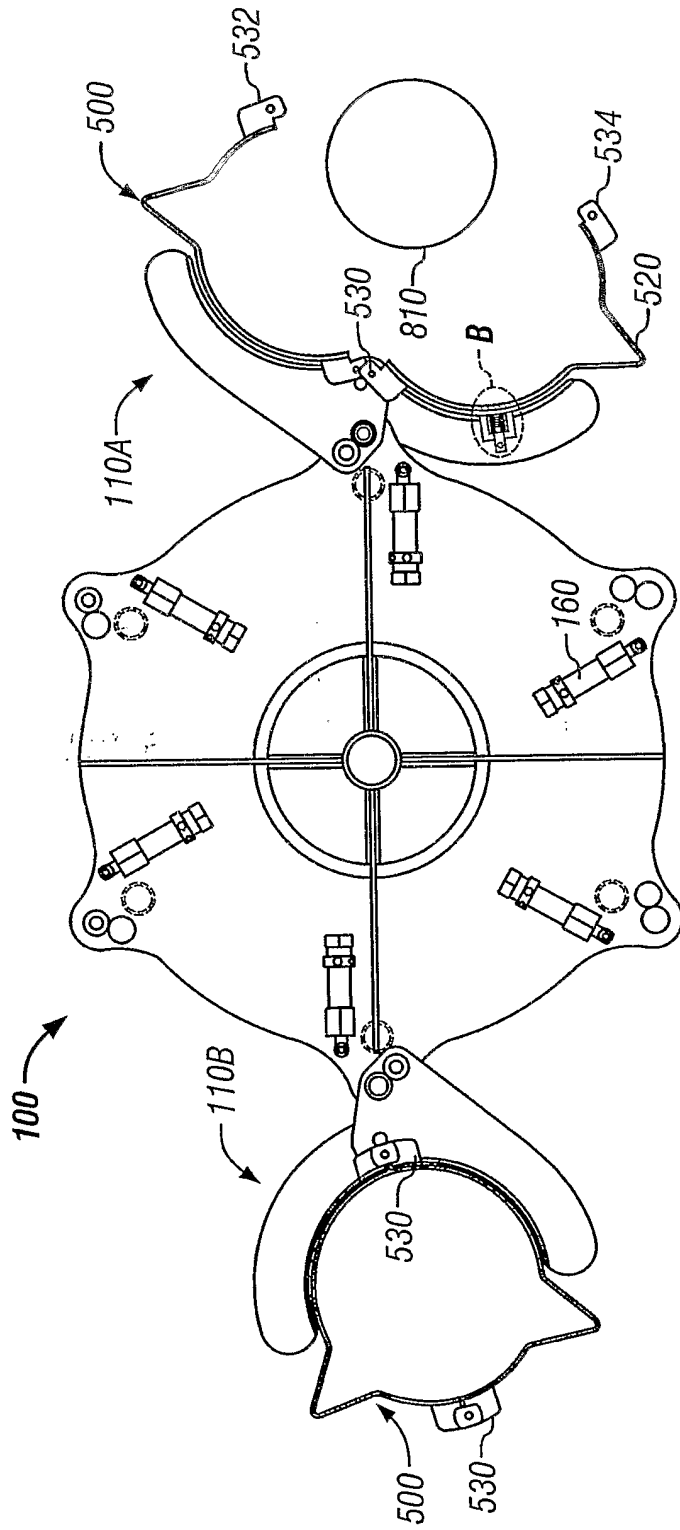

FIG. 8A

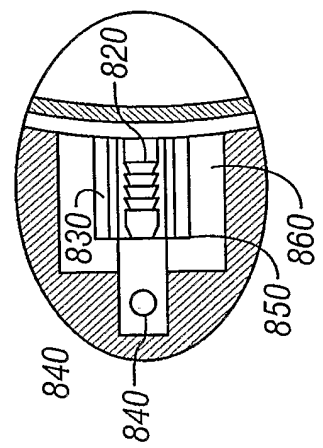

FIG. 8B

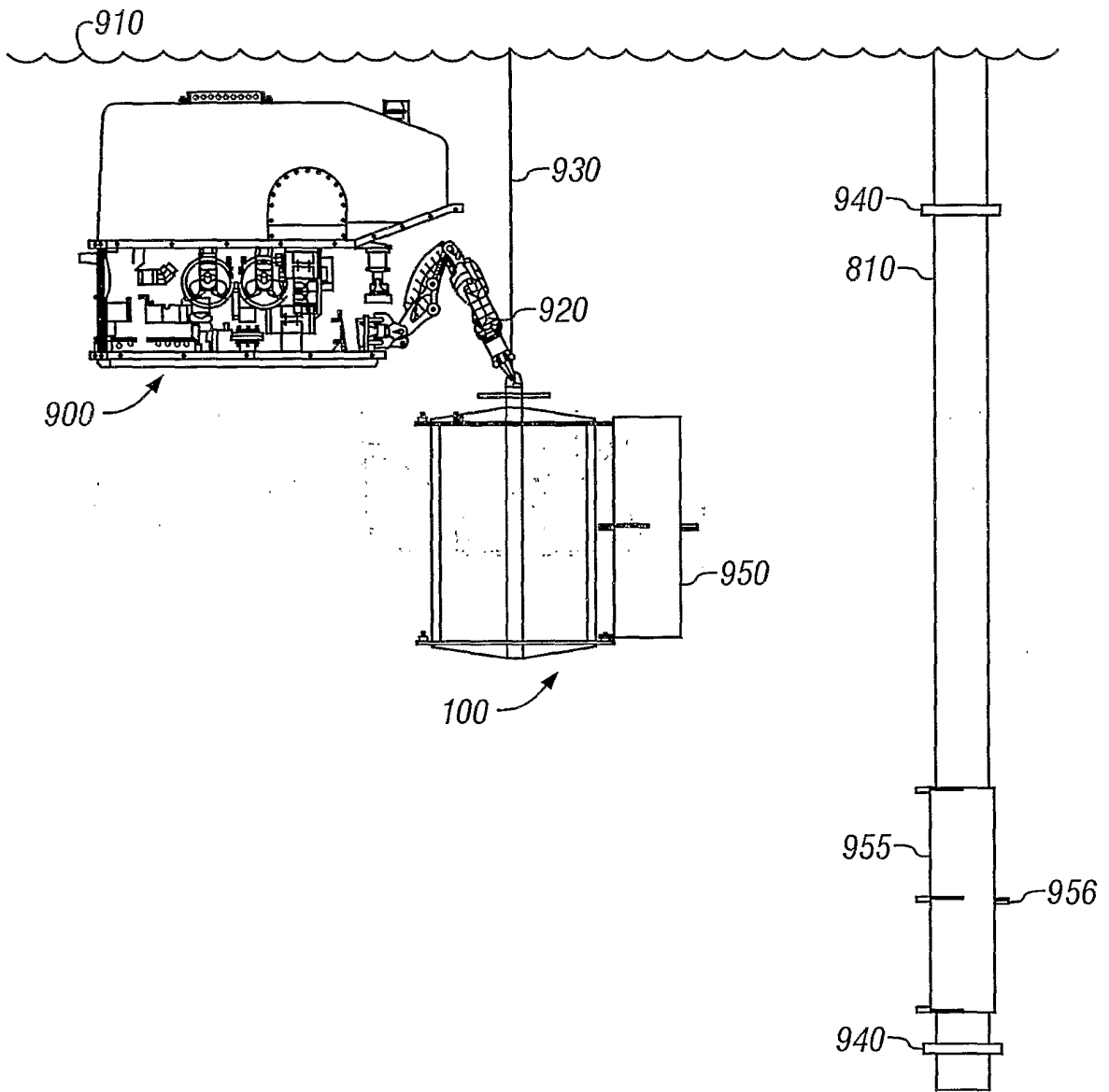

FIG. 9

6/21

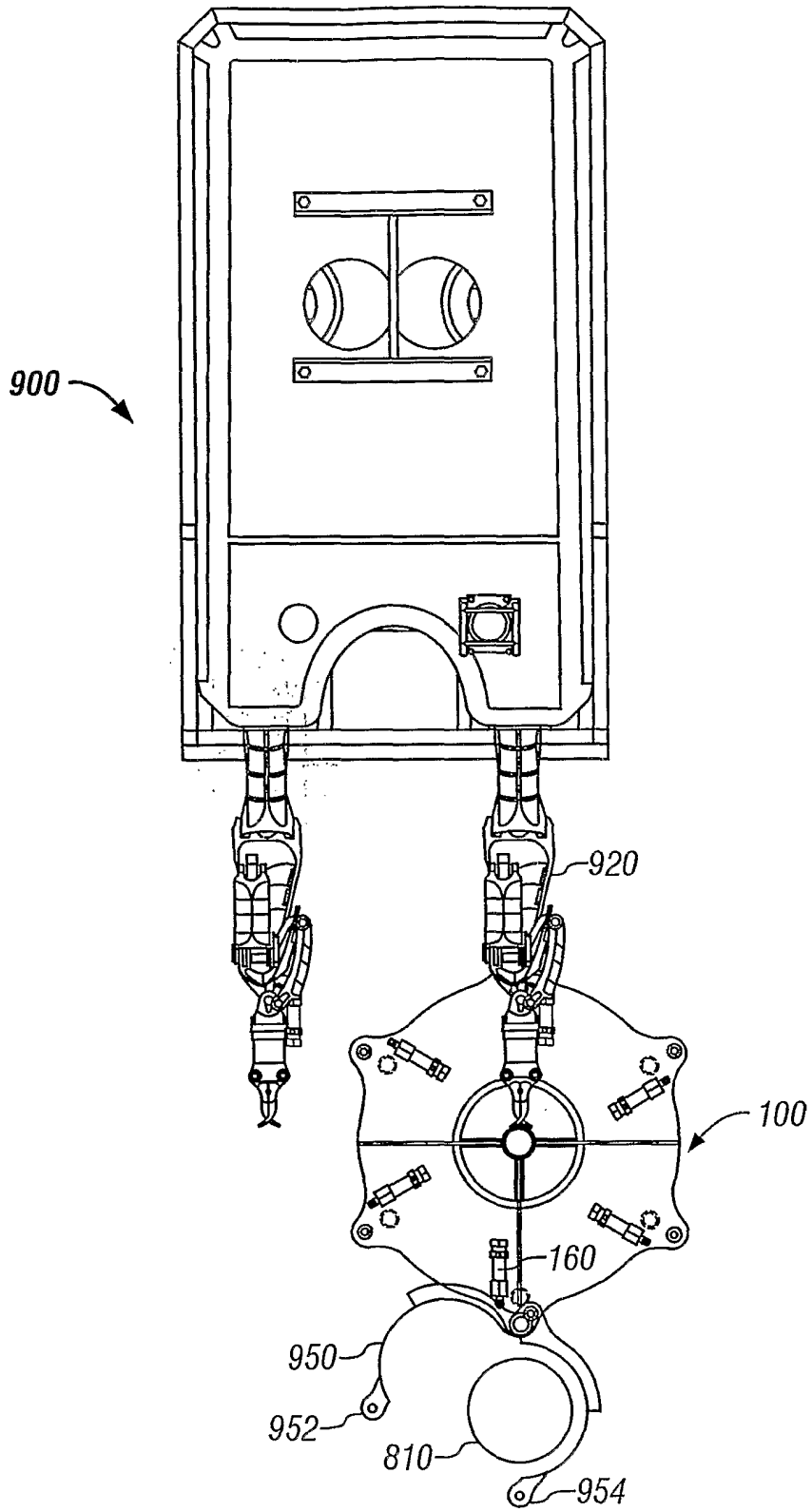

FIG. 10

7/21

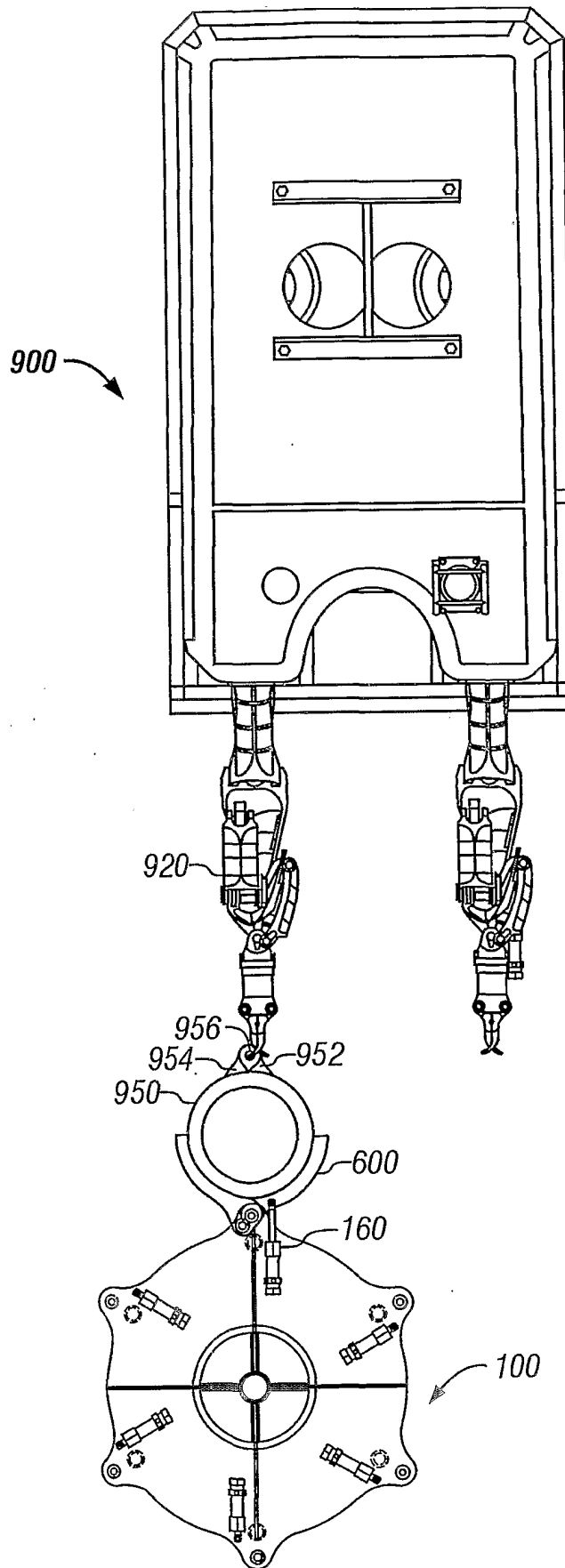

FIG. 11

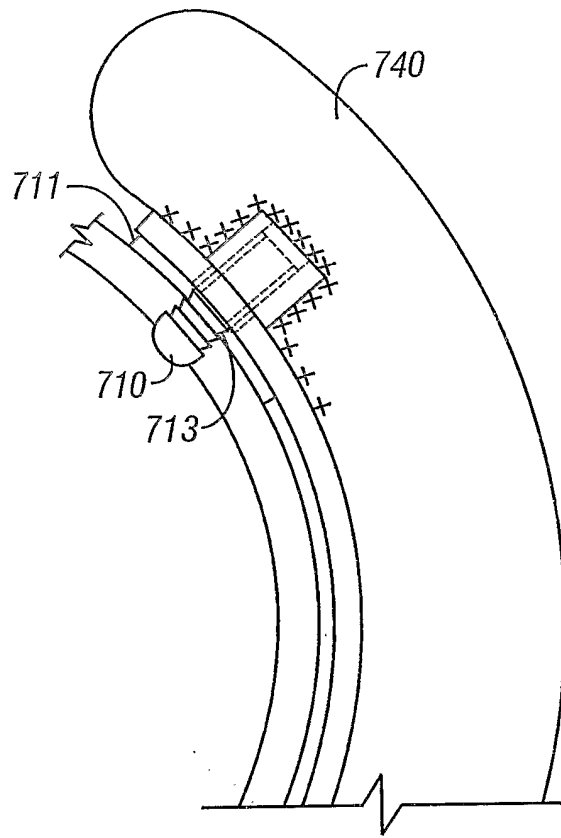

FIG. 12

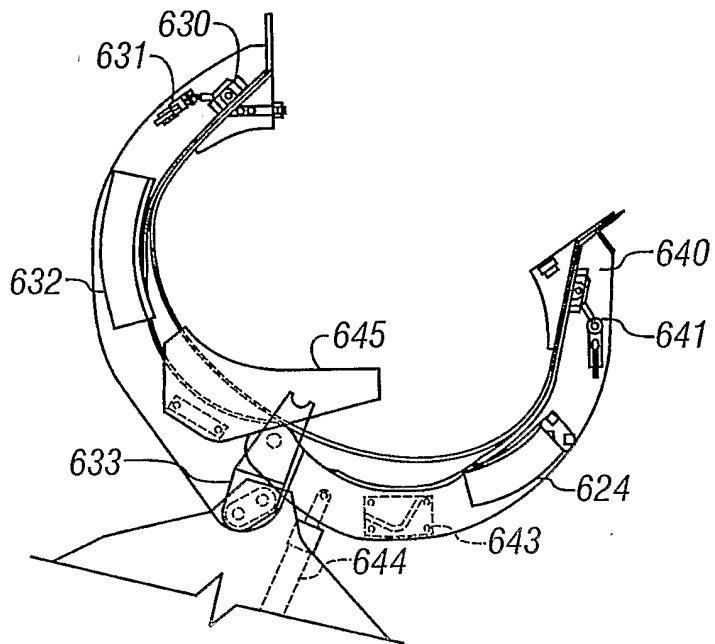

FIG. 13

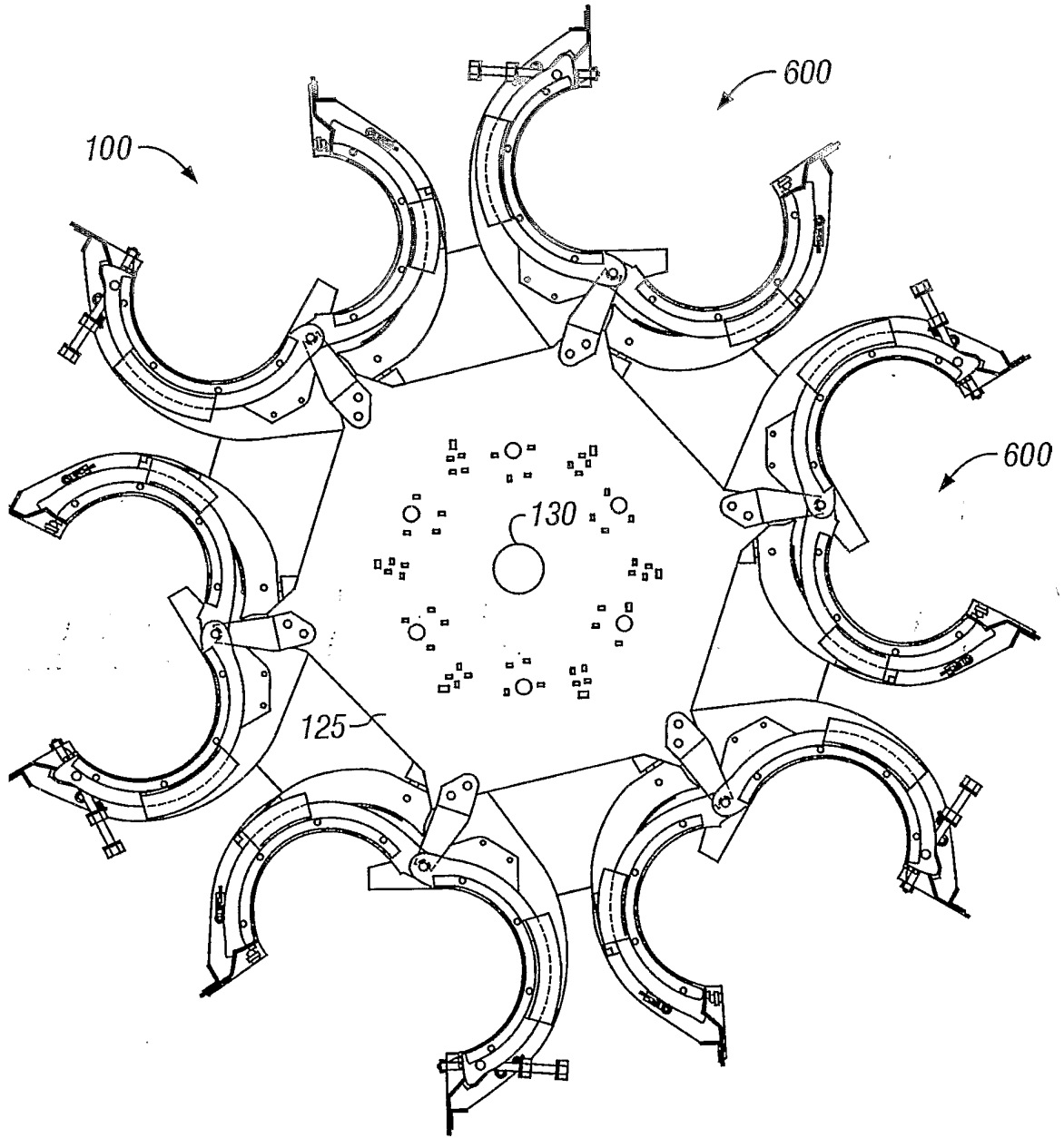

FIG. 14

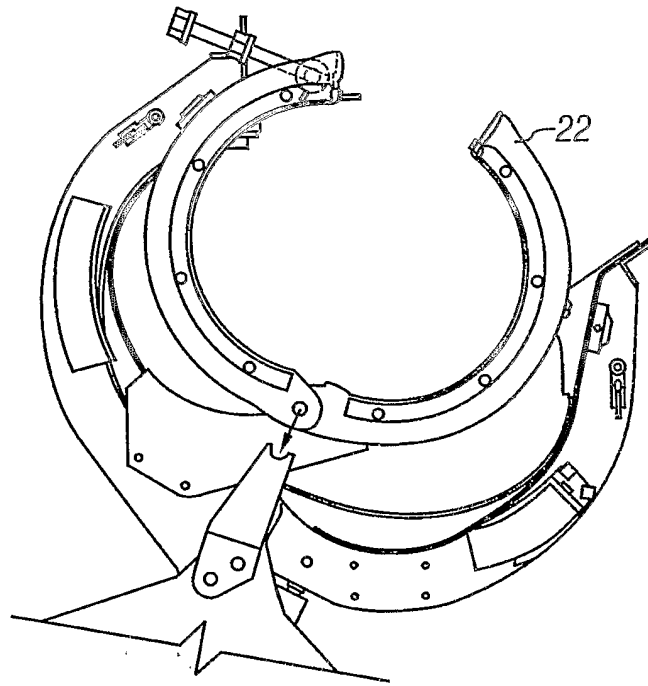

FIG. 15

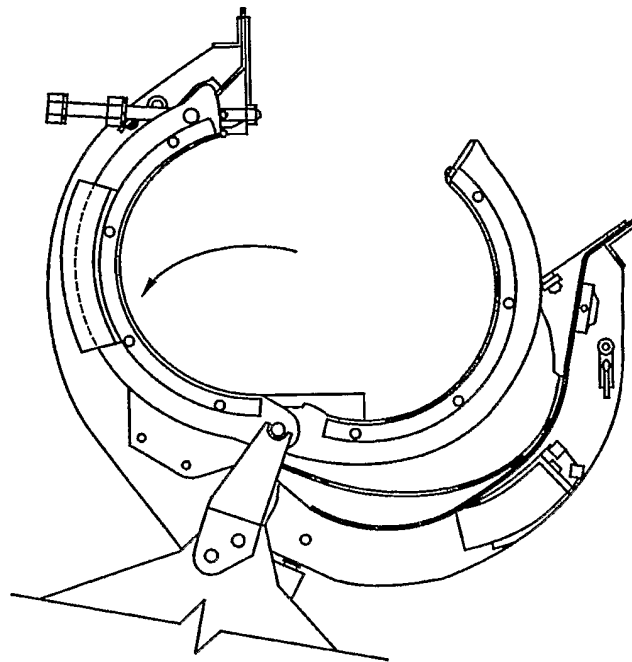

FIG. 16

11/21

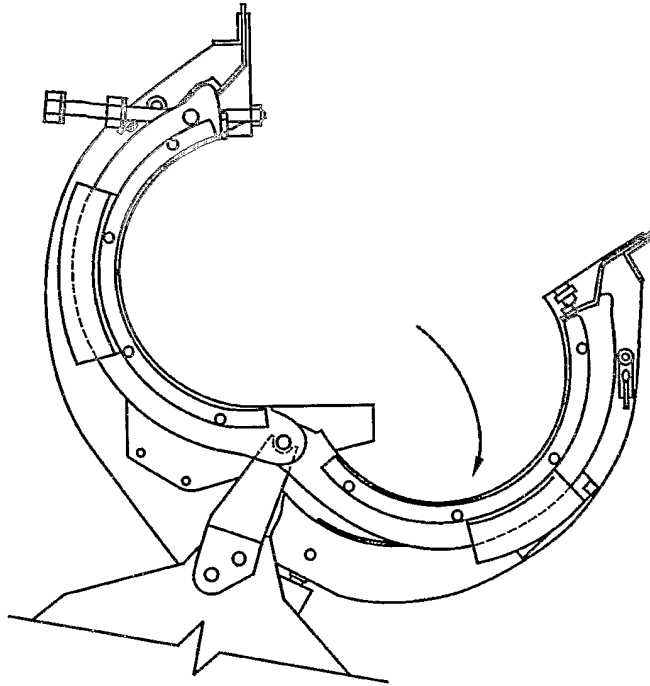

FIG. 17

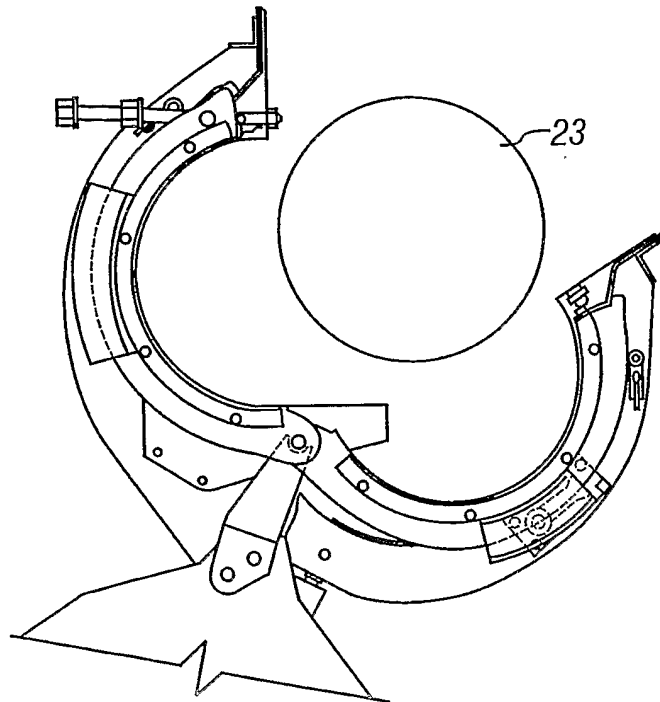

FIG. 18

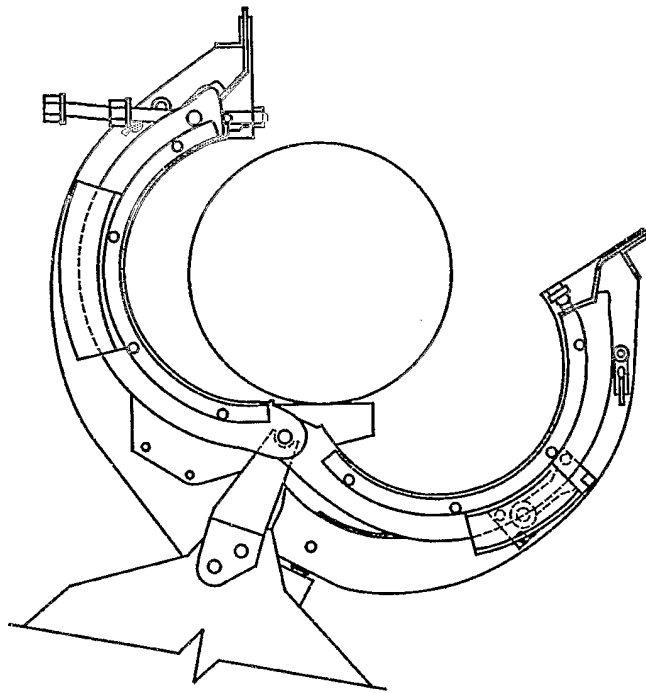

FIG. 19

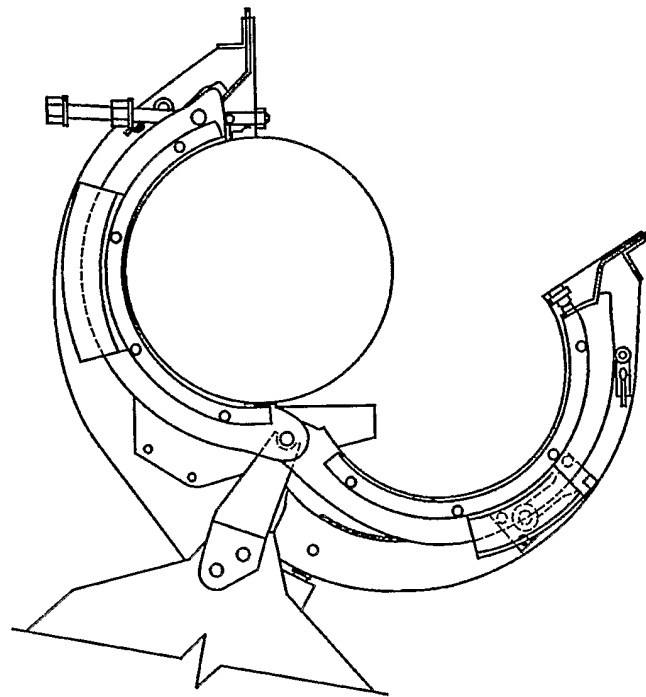

FIG. 20

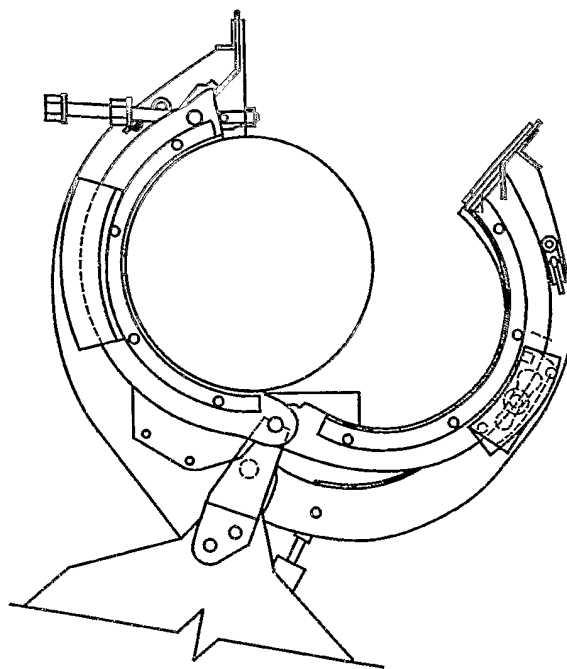

FIG. 21

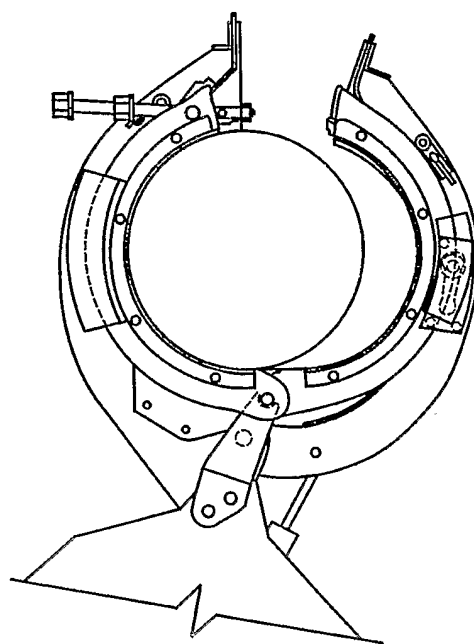

FIG. 22

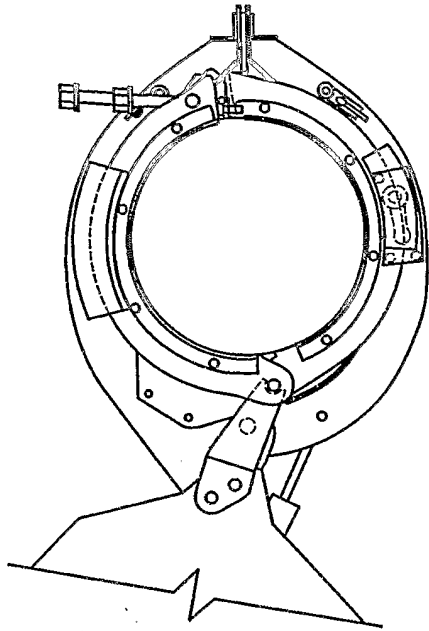

FIG. 23

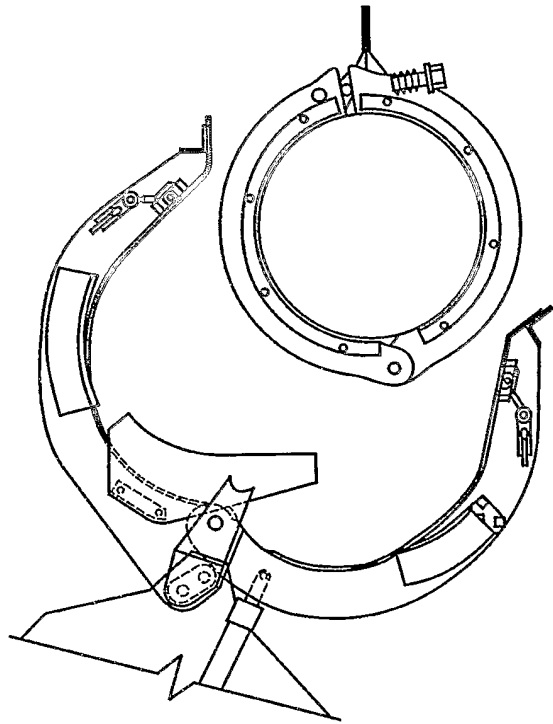

FIG. 24

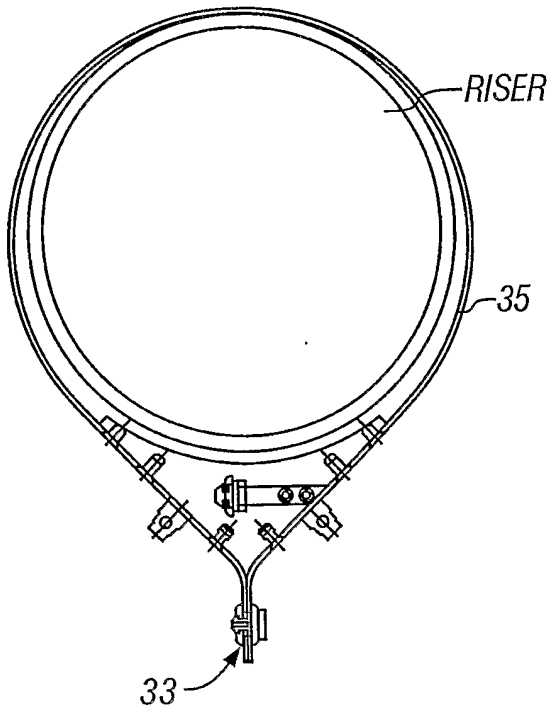

FIG. 25A

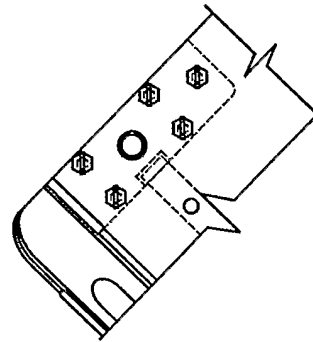

FIG. 25B



FIG. 25C

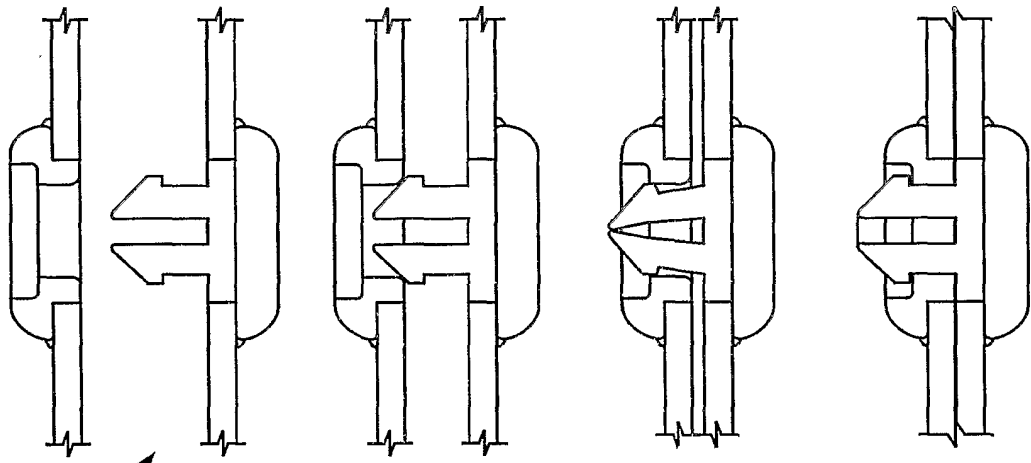

FIG. 26A

FIG. 26B

FIG. 26C

FIG. 26D

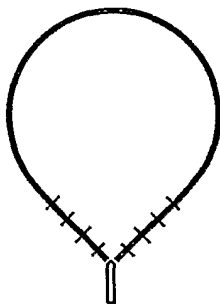

FIG. 27A

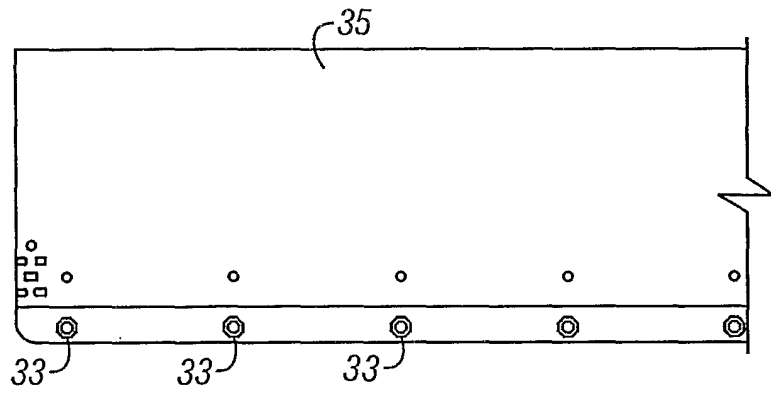

FIG. 27B

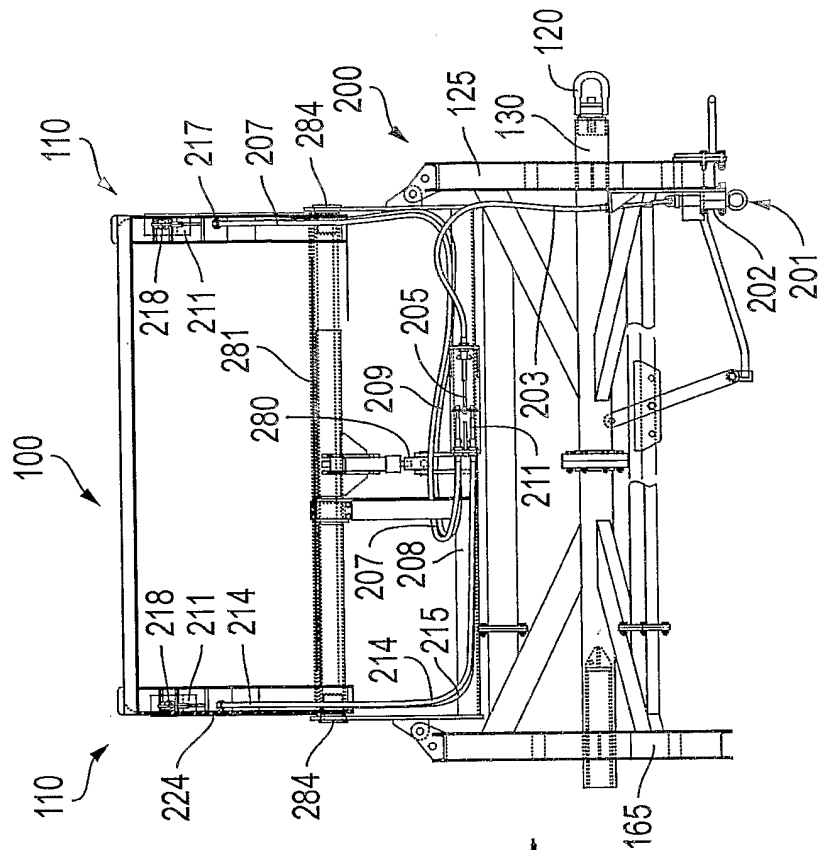

FIG. 29

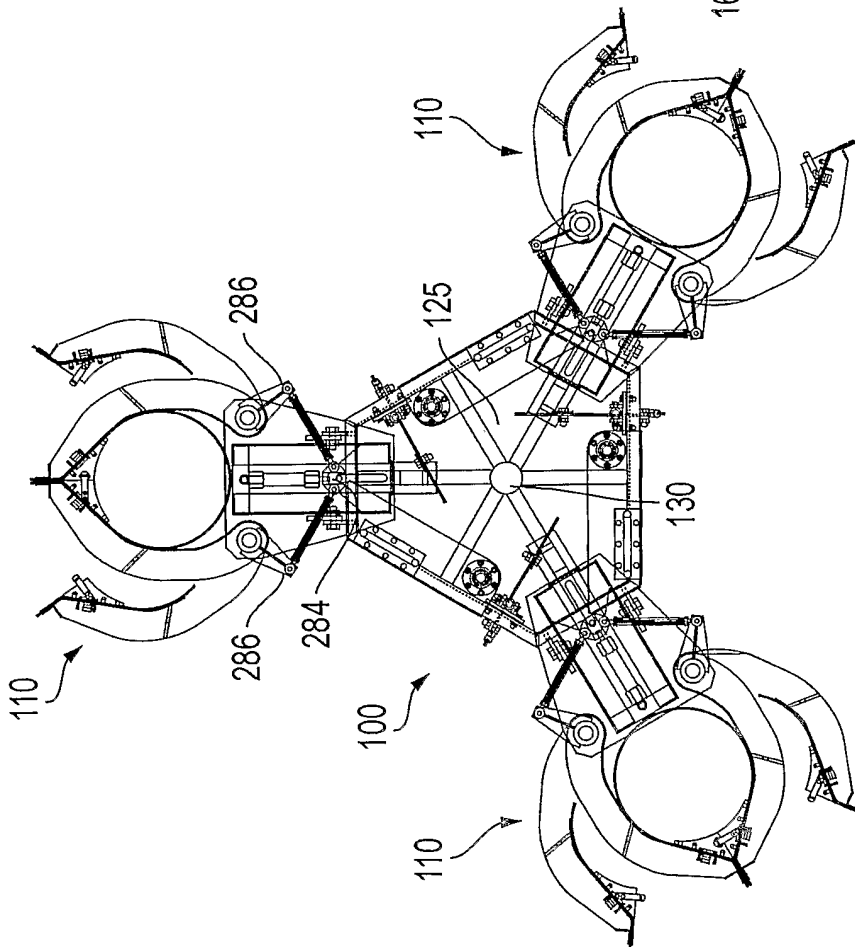

FIG. 28

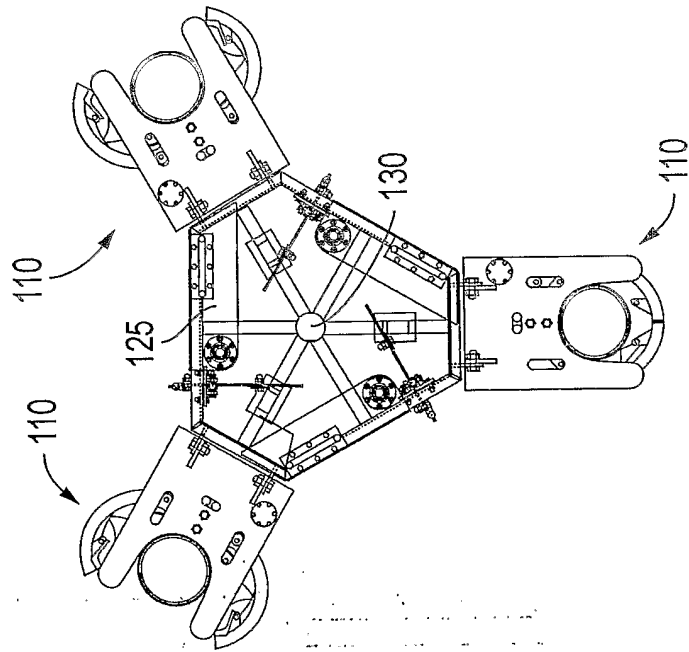

FIG. 31

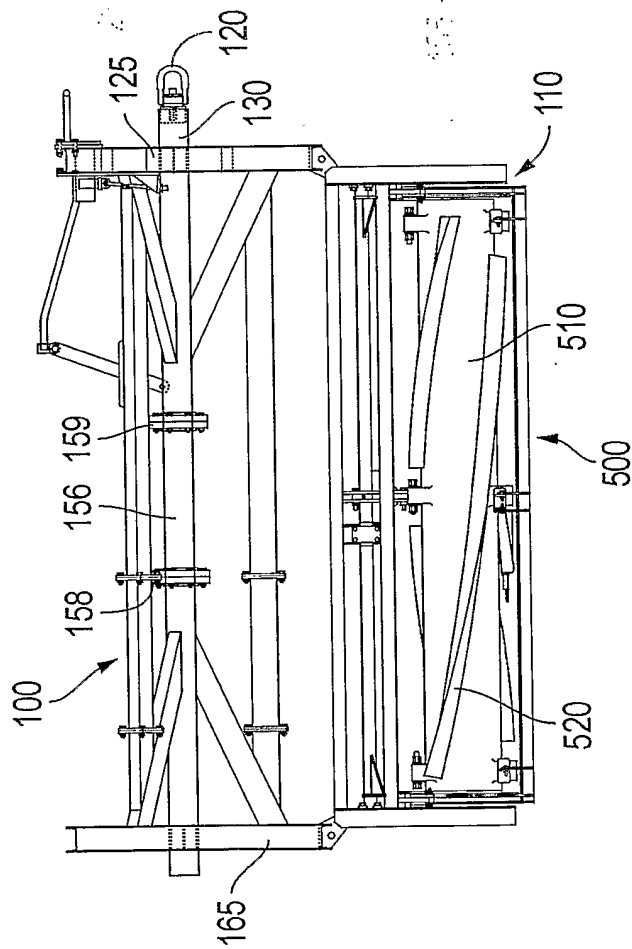

FIG. 30

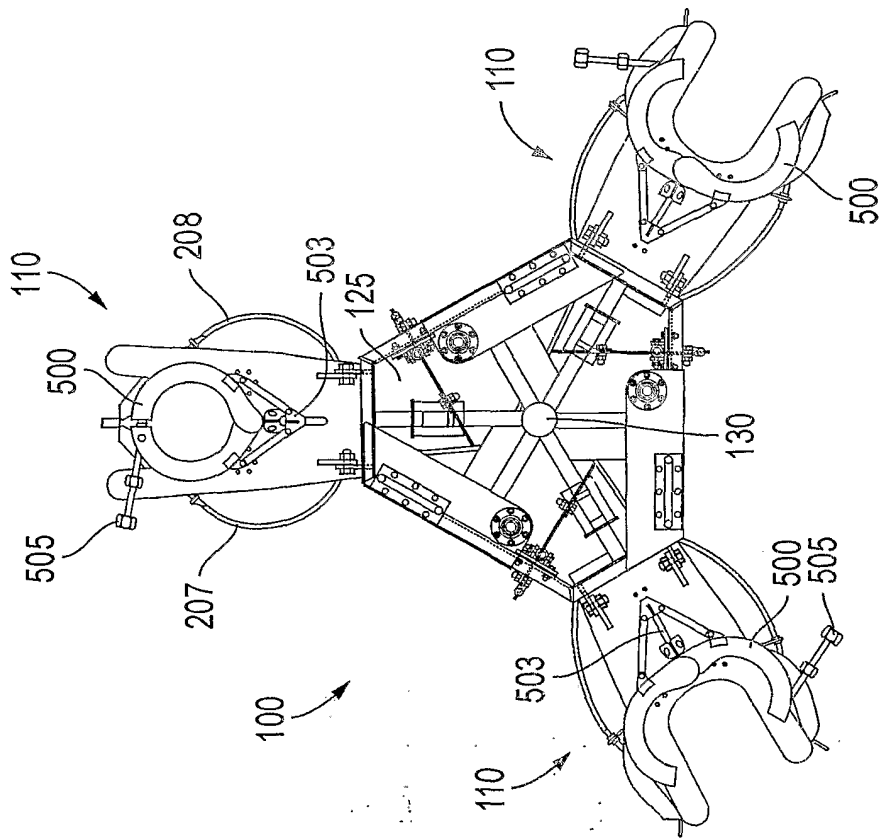

FIG. 33

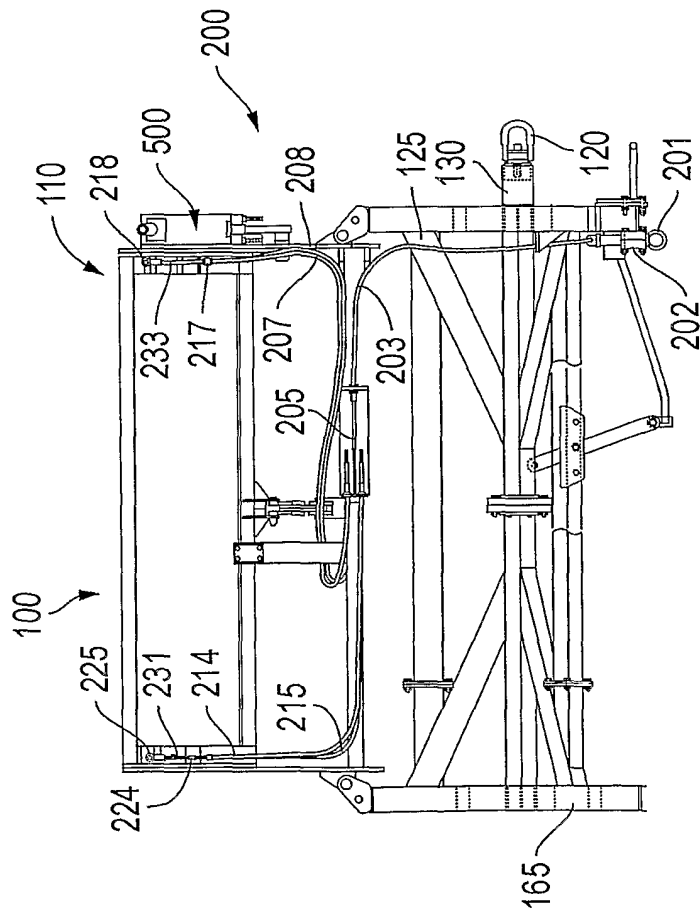

FIG. 32

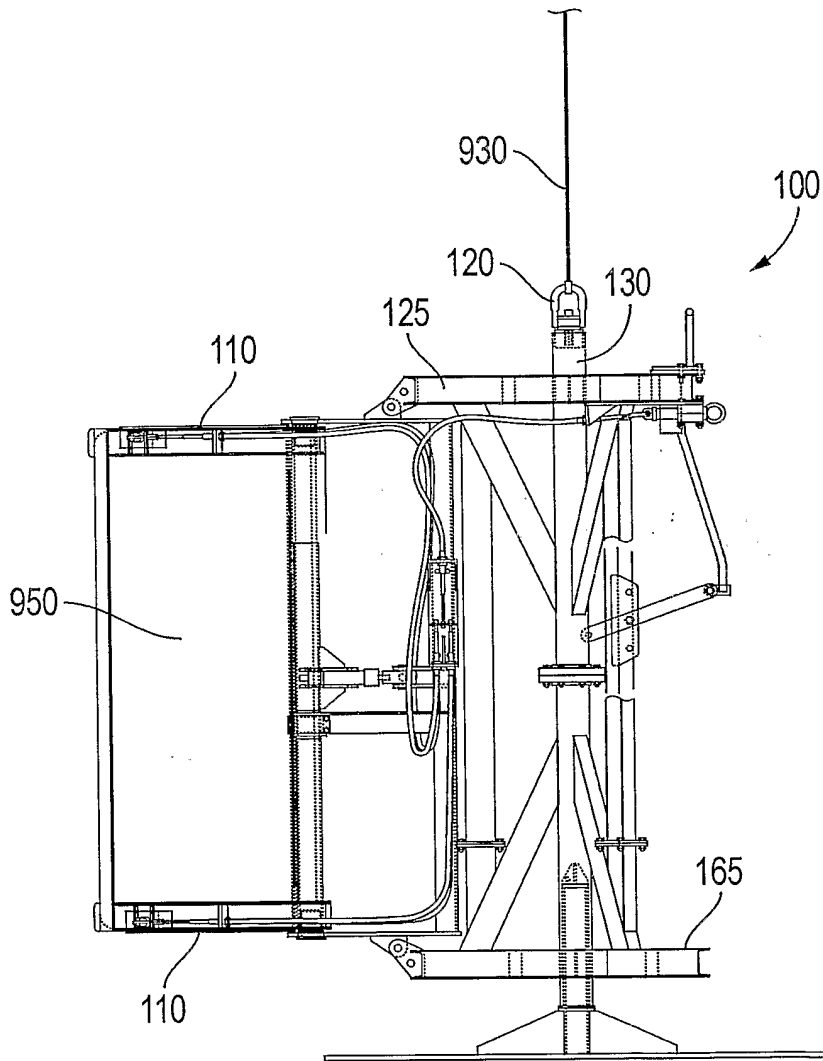

FIG. 34

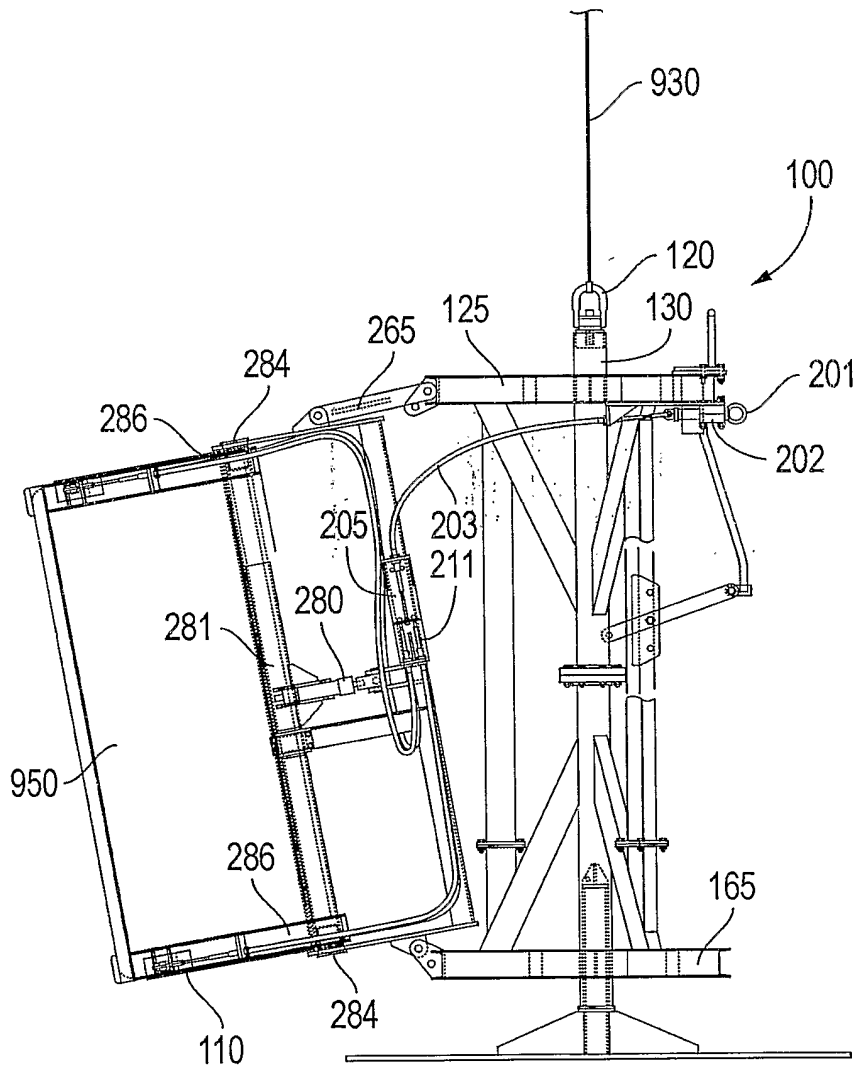

FIG. 35

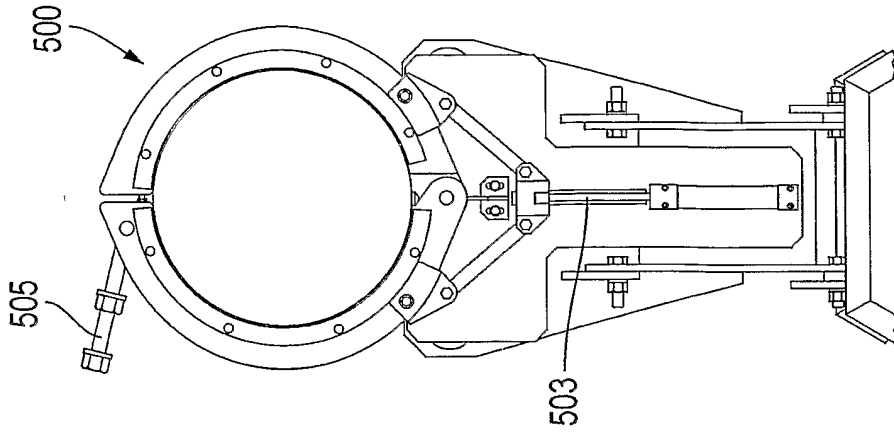

FIG. 36

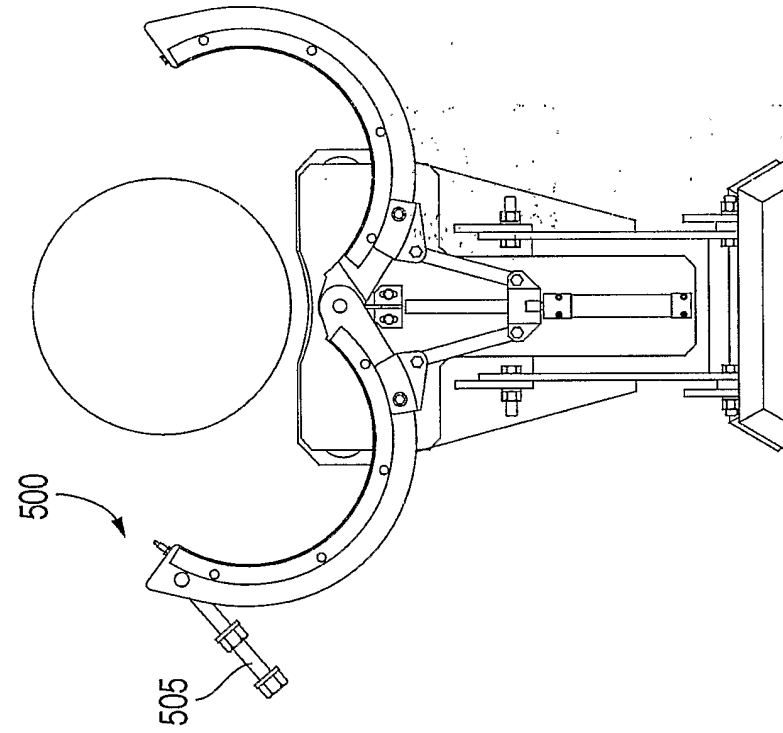

FIG. 37

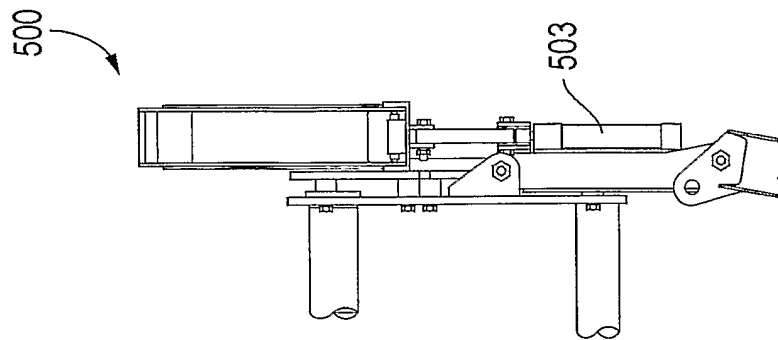

FIG. 38

INTERNATIONAL SEARCH REPORT

International Application No
PCT/US2004/006660

| A. CLASSIFICATION OF SUBJECT MATTER IPC 7 E21B41/04 | | | | |
|--|---|---|---|---|
| According to International Patent Classification (IPC) or to both national classification and IPC | | | | |
| B. FIELDS SEARCHED | | | | |
| Minimum documentation searched (classification system followed by classification symbols) IPC 7 E21B B63B | | | | |
| Documentation searched other than minimum documentation to the extent that such documents are included in the fields searched | | | | |
| Electronic data base consulted during the international search (name of data base and, where practical, search terms used) EPO-Internal | | | | |
| C. DOCUMENTS CONSIDERED TO BE RELEVANT | | | | |
| Category ° | Citation of document, with indication, where appropriate, of the relevant passages | Relevant to claim No. | | |
| X | US 4 648 782 A (KRAFT BRETT W) 10 March 1987 (1987-03-10) figures 1,4 | 1-4, 6-15, 17-22 | | |
| X | US 3 381 485 A (HARDENBROOK JAMES M ET AL) 7 May 1968 (1968-05-07) figure 2 | 1-4, 6-15, 17-22 | | |
| X | US 4 010 619 A (HIGHTOWER JOHN D ET AL) 8 March 1977 (1977-03-08) figure 6 | 1-4, 6-15, 17-22 | | |
| | -/-- | | | |
| <input checked="" type="checkbox"/> Further documents are listed in the continuation of box C. <input checked="" type="checkbox"/> Patent family members are listed in annex. | | | | |
| ° Special categories of cited documents : | | | | |
| <table border="0"> <tr> <td style="vertical-align: top;"> *A* document defining the general state of the art which is not considered to be of particular relevance *E* earlier document but published on or after the international filing date *L* document which may throw doubts on priority claim(s) or which is cited to establish the publication date of another citation or other special reason (as specified) *O* document referring to an oral disclosure, use, exhibition or other means *P* document published prior to the international filing date but later than the priority date claimed </td> <td style="vertical-align: top; padding-left: 20px;"> *T* later document published after the international filing date or priority date and not in conflict with the application but cited to understand the principle or theory underlying the invention *X* document of particular relevance; the claimed invention cannot be considered novel or cannot be considered to involve an inventive step when the document is taken alone *Y* document of particular relevance; the claimed invention cannot be considered to involve an inventive step when the document is combined with one or more other such documents, such combination being obvious to a person skilled in the art. *&* document member of the same patent family </td> </tr> </table> | | | *A* document defining the general state of the art which is not considered to be of particular relevance *E* earlier document but published on or after the international filing date *L* document which may throw doubts on priority claim(s) or which is cited to establish the publication date of another citation or other special reason (as specified) *O* document referring to an oral disclosure, use, exhibition or other means *P* document published prior to the international filing date but later than the priority date claimed | *T* later document published after the international filing date or priority date and not in conflict with the application but cited to understand the principle or theory underlying the invention *X* document of particular relevance; the claimed invention cannot be considered novel or cannot be considered to involve an inventive step when the document is taken alone *Y* document of particular relevance; the claimed invention cannot be considered to involve an inventive step when the document is combined with one or more other such documents, such combination being obvious to a person skilled in the art. *&* document member of the same patent family |
| *A* document defining the general state of the art which is not considered to be of particular relevance *E* earlier document but published on or after the international filing date *L* document which may throw doubts on priority claim(s) or which is cited to establish the publication date of another citation or other special reason (as specified) *O* document referring to an oral disclosure, use, exhibition or other means *P* document published prior to the international filing date but later than the priority date claimed | *T* later document published after the international filing date or priority date and not in conflict with the application but cited to understand the principle or theory underlying the invention *X* document of particular relevance; the claimed invention cannot be considered novel or cannot be considered to involve an inventive step when the document is taken alone *Y* document of particular relevance; the claimed invention cannot be considered to involve an inventive step when the document is combined with one or more other such documents, such combination being obvious to a person skilled in the art. *&* document member of the same patent family | | | |
| Date of the actual completion of the international search <p style="text-align: center;">5 August 2004</p> | | Date of mailing of the international search report <p style="text-align: center;">12/08/2004</p> | | |
| Name and mailing address of the ISA European Patent Office, P.B. 5818 Patentlaan 2 NL - 2280 HV Rijswijk Tel. (+31-70) 340-2040, Tx. 31 651 epo nl, Fax: (+31-70) 340-3016 | | Authorized officer <p style="text-align: center;">van Rooij, M</p> | | |

INTERNATIONAL SEARCH REPORT

International Application No
PCT/US2004/006660

C.(Continuation) DOCUMENTS CONSIDERED TO BE RELEVANT

| Category ° | Citation of document, with indication, where appropriate, of the relevant passages | Relevant to claim No. |
|------------|--|------------------------|
| X | US 3 434 295 A (MANNING WILLIAM F) 25 March 1969 (1969-03-25) figure 3 ----- | 1-4, 6-15, 17-22 |
| X | US 5 042 959 A (TADATSU GUNKICHI) 27 August 1991 (1991-08-27) figures ----- | 1-4, 6-15, 17-22 |
| A | US 3 163 221 A (SHATTO JR HOWARD L) 29 December 1964 (1964-12-29) figures 1,2 ----- | 1,8,12, 19 |
| A | EP 0 930 136 A (BTM CORP) 21 July 1999 (1999-07-21) figures ----- | 1,8,12, 19 |
| A | US 4 116 015 A (DUNCAN ANTHONY BRUCE) 26 September 1978 (1978-09-26) figures ----- | 1,8,12, 19 |

INTERNATIONAL SEARCH REPORT

Information on patent family members

| |
|--|
| International Application No PCT/US2004/006660 |
|--|

| Patent document cited in search report | A | Publication date | Patent family member(s) | Publication date |
|--|---|------------------|--|--|
| US 4648782 | A | 10-03-1987 | NONE | |
| US 3381485 | A | 07-05-1968 | NONE | |
| US 4010619 | A | 08-03-1977 | NONE | |
| US 3434295 | A | 25-03-1969 | NONE | |
| US 5042959 | A | 27-08-1991 | JP 1733784 C JP 2053693 A JP 4018117 B AU 609633 B2 AU 3933489 A CA 1312350 C DE 3926225 A1 FR 2636038 A1 GB 2221711 A , B IT 1232431 B KR 9403730 B1 NL 8902043 A , B, | 17-02-1993 22-02-1990 26-03-1992 02-05-1991 15-02-1990 05-01-1993 15-02-1990 09-03-1990 14-02-1990 17-02-1992 28-04-1994 01-03-1990 |
| US 3163221 | A | 29-12-1964 | GB 937894 A | 25-09-1963 |
| EP 0930136 | A | 21-07-1999 | US 6722842 B1 CA 2254032 A1 EP 0930136 A2 | 20-04-2004 13-07-1999 21-07-1999 |
| US 4116015 | A | 26-09-1978 | NONE | |