

(19) World Intellectual Property Organization
International Bureau



(43) International Publication Date
10 May 2002 (10.05.2002)

PCT

(10) International Publication Number
WO 02/36015 A1

- (51) International Patent Classification⁷: **A61B 8/00**
- (21) International Application Number: PCT/US01/48332
- (22) International Filing Date: 30 October 2001 (30.10.2001)
- (25) Filing Language: English
- (26) Publication Language: English
- (30) Priority Data:
60/244,255 30 October 2000 (30.10.2000) US
- (63) Related by continuation (CON) or continuation-in-part (CIP) to earlier application:
US 60/244,255 (CON)
Filed on 30 October 2000 (30.10.2000)
- (71) Applicant (for all designated States except US): **THE GENERAL HOSPITAL** [US/US]; 55 Fruit Street, Boston, MA 02114 (US).
- (72) Inventors; and
- (75) Inventors/Applicants (for US only): **TEARNEY, Guillermo, J.** [US/US]; 118 Kinnaird Steet #3, Cambridge, MA 02139 (US). **BOUMA, Brett, E.** [US/US]; 12 Monmouth Street, Quincy, MA 02171 (US).
- (74) Agent: **FASSE, J., Peter**; Fish & Richardson, 225 Franklin Street, Boston, MA 02110-2804 (US).
- (81) Designated States (national): AE, AG, AL, AM, AT, AU, AZ, BA, BB, BG, BR, BY, BZ, CA, CH, CN, CO, CR, CU, CZ, DE, DK, DM, DZ, EC, EE, ES, FI, GB, GD, GE, GH, GM, HR, HU, ID, IL, IN, IS, JP, KE, KG, KP, KR, KZ, LC, LK, LR, LS, LT, LU, LV, MA, MD, MG, MK, MN, MW, MX, MZ, NO, NZ, OM, PH, PL, PT, RO, RU, SD, SE, SG, SI, SK, SL, TJ, TM, TR, TT, TZ, UA, UG, US, UZ, VN, YU, ZA, ZW.
- (84) Designated States (regional): ARIPO patent (GH, GM, KE, LS, MW, MZ, SD, SL, SZ, TZ, UG, ZW), Eurasian patent (AM, AZ, BY, KG, KZ, MD, RU, TJ, TM), European patent (AT, BE, CH, CY, DE, DK, ES, FI, FR, GB, GR, IE, IT, LU, MC, NL, PT, SE, TR), OAPI patent (BF, BJ, CF, CG, CI, CM, GA, GN, GQ, GW, ML, MR, NE, SN, TD, TG).
- Published:**
— with international search report
— before the expiration of the time limit for amending the claims and to be republished in the event of receipt of amendments
- For two-letter codes and other abbreviations, refer to the "Guidance Notes on Codes and Abbreviations" appearing at the beginning of each regular issue of the PCT Gazette.*



WO 02/36015 A1

(54) Title: OPTICAL METHODS AND SYSTEMS FOR TISSUE ANALYSIS

(57) Abstract: The invention relates to methods and systems to optically analyze samples such as tissue based on speckle patterns of microscopic motion, such as Brownian motion.

5 **Optical Methods and Systems for Tissue Analysis**

CROSS-REFERENCE TO RELATED APPLICATION

This application claims benefit of priority from U.S. Provisional Patent Application Serial No. 60/244,255, filed on October 30, 2000, which is incorporated herein by reference in its entirety.

10 **TECHNICAL FIELD**

The invention relates to tissue analysis, and more particularly to characterizing tissue by analyzing speckle patterns formed by light reflected from tissue.

BACKGROUND

15 “Speckle” is an interference phenomenon that occurs when coherent light (e.g., laser light) is reflected from a rough or multiply scattering sample onto a detection plane. Due to scattering of photons from and within the sample, different photons travel different distances to the detection plane. As a result, the light reflected or backscattered from the sample, if spatially and temporally coherent, interferes at the detection plane, producing a grainy pattern known as “speckle.”

20 Researchers have used speckle pattern analysis to study dynamic movement of tissue *in vivo*. For example, speckle has been used to measure vibrations of tissue, V. Tuchin et al., “Speckle interferometry in the measurements of biotissues vibrations,” SPIE, 1647: 125 (1992), and to measure strain in vascular and cortical tissue in response to forced movement of the tissue, Sean J. Kirkpatrick et al., “Laser Speckle Microstrain Measurement in Vascular Tissue,” SPIE, 3598: 121-128 (1999); and Sean J. Kirkpatrick and Brent W. Brooks, “Micromechanical Behavior of Cortical Bone as Inferred from Laser Speckle Data,” J. Biomedical Materials Research, 39(3): 373-79 (1998).
25 Researchers have also used speckle to study blood flow and lymph flow. B. Ruth, “Blood Flow Determination by the Laser Speckle Method,” Int’l J. Microcirc: Clinical and Experimental, 9(1): 21-45 (1990); and A.A. Bednov et al., “Investigation of
30 Statistical Properties of Lymph Flow Dynamics Using Speckle-Microscopy,” SPIE, 2981: 181-90 (1997).

5

SUMMARY

The invention is based on the discovery that tissues can be analyzed *in vivo* using laser speckle to measure microscopic motion, e.g., Brownian motion, of structures and characteristics within the tissue.

In general, the invention features a method of analyzing tissue, e.g., *in vivo*, by
10 illuminating a tissue with coherent light, such as laser light, or partially coherent light; receiving light reflected from the tissue at a detector to form a series of speckle patterns; and analyzing changes in the speckle patterns at time intervals sufficient to measure changes caused by motion of objects within the tissue on a microscopic scale, e.g., less than about 1 mm (e.g., less than about 500 or 100 microns), such as Brownian motion of
15 molecules or macromolecules, or motion of cells or cellular organelles, or other non-random forms of motion such as lymph or intracellular transmembrane flow, while eliminating motion on a macroscopic scale, e.g., greater than about 1 mm.

For example, the speckle patterns can be measured at a near field or at a far field and imaged onto the detector. "Near field" is measurement of the speckle distribution
20 less than one wavelength of light from the surface of a tissue, while "far field" speckle is the interference pattern formed greater than one wavelength of light from the surface. The method can further include compensating for macroscopic or extrinsic motion, such as a heartbeat, patient motion, or peristalsis, to isolate the microscopic, e.g., Brownian, motion.

25 In this method, the illuminating step can include providing an invasive device coupled to a light source, passing the device into a patient, placing the device in proximity to the tissue, and shining coherent light or partially coherent light from the light source onto the tissue.

The invasive device can be, e.g., a catheter, an endoscope, or a laparoscope. The
30 device can be placed in direct contact with the tissue (to measure a near field speckle pattern) or may be a given distance from the tissue (to measure a far field or near field speckle pattern). The device can include a catheter having a first fiber (or fiber array or bundle) that transmits light from the light source to the tissue, and a fiber array or single

5 fiber that receives light remitted from the tissue. The fiber arrays can be one or two-dimensional. The analyzing step can include comparing each of the series of speckle patterns to a series of reference speckle patterns, and quantifying the temporal correlation differences between the patterns and the reference patterns. For example, the analyzing step can include digitizing each of the speckle patterns as a function of time and space,
10 and the quantifying step can include evaluating a cross-correlation between the patterns and the reference patterns. The analyzing step can further include determining a decorrelation rate for the speckle patterns, or analyzing spatial characteristics of the speckle pattern to deduce structural and/or biomechanical characteristics of the tissue. Biomechanical characteristics can include, for example, compliance, elasticity, stress,
15 strain, and viscosity. In these methods, speckle pattern data is a snapshot taken at a specific point in time. Speckle pattern correlation data is a measurement of cross-correlation of the speckle pattern as a function of time.

In variations, the method can include illuminating multiple locations of the tissue in succession, forming a separate series of speckle patterns for each respective location of
20 the tissue, and then analyzing each separate series of speckle patterns and comparing the separate series to deduce structural and/or biomechanical differences between the respective locations of the tissue.

In certain embodiments, the method includes gathering reflected light at a light receptor and transmitting the gathered light to the detector, and compensating for
25 macroscopic motion by coupling the receptor to the tissue. Compensating for macroscopic motion can also be done by excluding changes in the speckle patterns caused by non-random motion during the analysis step. Macroscopic or extrinsic motion can also result, for example, from blood flowing between the tissue and the reflector. In those cases, the compensating step can include replacing the blood with a transparent
30 solution and/or eliminating correlated speckle pattern information corresponding to directional blood flow.

In another embodiment, the invention features a method of analyzing a tissue structure, e.g., for determining the susceptibility to rupture of an atherosclerotic plaque

5 having a lipid pool and a fibrous cap. The method includes illuminating the tissue structure, e.g., plaque, with coherent or partially coherent light; receiving light reflected from the tissue structure at a detector to form a series of speckle patterns; gathering speckle pattern data at time intervals sufficient to measure microscopic motion, e.g., Brownian motion or other forms of microscopic motion, within the tissue structure or
10 tissue adjacent the tissue structure, such as a lipid pool; and assessing the tissue structure, e.g., assessing a plaque's vulnerability to rupture from the amount of Brownian motion.

The method can further include analyzing spatial characteristics of the speckle pattern data to determine structural and/or biomechanical characteristics of the tissue structure, e.g., plaque, for example, by assessing the thickness of the tissue structure, e.g.,
15 fibrous cap. The thickness of the tissue can be determined by measuring the spatial and temporal decorrelation of the speckle pattern as a function of distance from the incident beam entry point. Near the beam entry point, the speckle pattern will be more stationary. Far away from the beam entry point, the speckle pattern will decorrelate more rapidly. The location of the transition is an indication of thickness. Other methods for
20 determining thickness are described herein. A plaque is considered vulnerable to rupture if the thickness of the fibrous cap is less than about 60 microns. The method can also be used to assess the viscosity of the lipid pool, wherein the plaque is considered vulnerable to rupture if the viscosity of the lipid pool has a time constant of less than about 200 milliseconds, and considered likely to rupture if the viscosity of the lipid pool has a time
25 constant of less than about 100 milliseconds.

The invention also includes a method of detecting a vulnerable atherosclerotic plaque having a lipid pool and a fibrous cap within a blood vessel by illuminating a segment of the blood vessel in vivo with coherent or partially coherent light; receiving light reflected from the interior vessel wall of the segment at a detector to form a series of
30 speckle patterns; gathering speckle pattern data at time intervals sufficient to measure microscopic, e.g., Brownian, motion within the interior vessel wall; and comparing the speckle pattern correlation data to a known speckle pattern time correlation data. One means for comparing the measured speckle pattern correlation data with a reference

5 speckle pattern correlation data is by the time constant, or the time it takes for the speckle pattern to decorrelate by $1/e$. For example, the decorrelation time constant for any given segment of vessel may be measured and compared to known time constants for normal vessels, atherosclerotic vessels, lipid pools with thick fibrous caps and lipid pools with thin fibrous caps (vulnerable plaques). If the time constant indicates the presence of a
10 lipid pool ($\tau < 100$ ms), with a thin fibrous cap, spatial characteristics of the speckle pattern data can be further analyzed to determine structural characteristics of the plaque as described herein. In addition, the first (mean) and second (standard deviation) of the probability distribution function pattern (histogram) of the speckle pattern is unique for different plaque types.

15 In another aspect, the invention features a fiber optic probe for detecting speckle patterns in a sample. The probe includes a catheter including a rotatable inner shaft and a transparent outer sheath; a fiber array or single fiber housed within the shaft and comprising one or more first optical fibers for transmitting incident light to the sample, and one or more second optical fibers for transmitting light remitted from the sample; and
20 a mirror arranged near a distal end of the shaft to reflect light passing through the fiber array onto a sample outside the transparent outer sheath and back from the sample through the fiber array. The fiber array can include one (or several) incident light transmitting fiber, one (or more) remitted light transmitting fiber, and the incident light transmitting fiber can be selected from the array, and thereafter a different fiber can be
25 selected, e.g., in series, to scan the incident light across the sample without moving the probe.

The beam emanating from the one or more first optical fibers can be focused onto the tissue by a lens, and the speckle pattern can be imaged onto the detection fiber array or onto a single detection fiber by a lens. In some embodiments, the shaft can rotate 360
30 degrees within the sheath, and an inflatable balloon can be connected to the sheath.

The invention further includes an optical system for detecting speckle patterns in a sample. The system has a fiber optic probe as described herein; a coherent or partially coherent light source connected to the central optical fiber within the fiber array; a

5 detector to receive light remitted from the sample; and a processor to process the remitted
light and to analyze speckle patterns remitted from the sample. For example, the
processor can include reference speckle pattern time constants or a whole library of
reference speckle pattern time constants, or reference speckle pattern correlation curves,
e.g., for healthy and diseased tissue. The system can also include an analog-digital
10 converter to convert the analog remitted light into a digital signal.

As used herein, "tissue" means any biological structure in or on a body. Tissue
includes aggregates of cells, growths, and deposits such as plaque that may contain lipids
or other components. Specific components of plaques that can be investigated include
lipid pools, calcifications, fibrous regions, and fibrous caps.

15 "Speckle" is an interference phenomenon that occurs when coherent or partially
coherent light is reflected from a rough or multiply scattering sample onto a detection
plane. A "speckle pattern" is the intensity pattern that results from interference.

"Brownian motion" is the random motion of cells, molecules, and other
subcomponents within tissue.

20 "Coherence" is the property of light that allows interference of two or more
optical waves. "Partial coherence" refers to waves that can interfere with each other if
the path traveled by each wave is equivalent to or within the temporal coherence length
of the light at any given point in the specimen.

Unless otherwise defined, all technical and scientific terms used herein have the
25 same meaning as commonly understood by one of ordinary skill in the art to which this
invention belongs. Although methods and materials similar or equivalent to those
described herein can be used in the practice or testing of the present invention, suitable
methods and materials are described below. All publications, patent applications,
patents, and other references mentioned herein are incorporated by reference in their
30 entirety. In case of conflict, the present specification, including definitions, will control.
In addition, the materials, methods, and examples are illustrative only and are not
intended to be limiting.

5 Other features and advantages of the invention will be apparent from the following detailed description and from the claims.

BRIEF DESCRIPTION OF THE DRAWINGS

Fig. 1 is a cross-sectional schematic of an optical catheter for gathering speckle data from tissue *in vivo*.

10 Fig. 2A is a cross-sectional schematic illustrating the catheter of Fig. 1, with an attached angioplasty balloon, inserted within a blood vessel, with the balloon deflated.

Fig. 2B is a cross-sectional schematic illustrating the catheter of Fig. 1, with an attached angioplasty balloon, inserted within a blood vessel, with the balloon inflated.

15 Fig. 3 is a speckle pattern produced from a cadaveric human aorta using incident light of $\lambda = 632.8$ nm.

Fig. 4 is a schematic illustrating reflectance of incident light from an atherosclerotic plaque.

20 Fig. 5 is representative raw data speckle images, edge images, and cross-correlation images used to assess the viscosity of a lipid-rich, atherosclerotic plaque in a human aorta.

Fig. 6 is representative raw data speckle images, edge images, and cross-correlation images used to assess the viscosity of normal human aorta tissue.

25 Fig. 7 is an exponential graph showing speckle decorrelation of a thin cap atherosclerotic plaque, a thick cap atherosclerotic plaque, and normal aortic tissue over a time interval.

DETAILED DESCRIPTION

At a microscopic level, most tissue is not static. Individual cells move within intercellular fluids, cellular organelles move within cells, and large molecules move back and forth between cells. In non-cellular tissue deposits such as plaques, components such as proteins, lipids, and other molecules also exhibit local motion. These local
30 microscopic motions include "Brownian motion" and are essentially random in nature. Measuring and characterizing the microscopic motion of tissues can provide useful

5 information about the structure, composition, biomechanical characteristics, and stability of the tissue.

The invention relates to using laser speckle to measure microscopic motion, including Brownian motion, of tissue *in vivo* to gather information about the tissue. In general, coherent or partially light is reflected from a tissue to form a speckle pattern at a
10 detector. Due to motion of reflectors within the tissue, the speckle pattern changes over time, or “decorrelated.” By monitoring the rate of decorrelation, while compensating for “extrinsic,” macroscopic motion of the tissue, microscopic motion in the tissue can be isolated and measured. The partially coherent light can provide more information about optical properties of the tissue than completely coherent light.

15 In some embodiments of the invention, speckle analysis is used to measure microscopic, e.g., Brownian, motion in atherosclerotic plaques to detect plaques that are vulnerable to rupture, and, more specifically, to determine the plaque’s vulnerability to rupture. In these embodiments, a modified optical catheter (probe) or other instrument is inserted into a blood vessel (e.g., artery) to locate these plaques, and once a plaque is
20 located, the probe is moved into the proximity of the specific atherosclerotic plaque. Light reflected from the interior wall of the blood vessels, and/or from a plaque, is collected and transmitted to a detector, where a speckle pattern is formed. The speckle patterns of normal tissue and plaque tissue (especially vulnerable plaque tissue) are different, and these differences can be used to detect the plaques. Thereafter, e.g., while
25 compensating for macroscopic motion of the plaque, the speckle pattern is monitored over time to calculate the pattern’s rate of decorrelation. From this decorrelation rate, the degree of microscopic motion in the plaque, and therefore the plaque’s vulnerability to rupture, can be assessed.

30 I. Atherosclerotic Plaques

Rupture of an atherosclerotic plaque can lead to acute myocardial infarction, which is a leading cause of death in industrialized countries. When an atherosclerotic

5 plaque ruptures, lipids from the plaque enter the vessel lumen, potentially causing thrombosis, arterial occlusion, myocardial ischemia, and infarction.

According to recent research, plaques vulnerable to rupture generally have a thin, unstable, fibrous cap and a compliant, or less "viscous," lipid pool. See, e.g., Virmani et al., "Lesions from sudden coronary death: A comprehensive morphological classification
10 scheme for atherosclerotic lesions," *Arterioscler. Thromb. Vasc. Bio.*, 20:1262-75 (2000) and Lee et al., "The Unstable Atheroma," *Arteriosclerosis, Thrombosis & Vascular Biology*, 17:1859-67 (1997). The less viscous lipid pool applies force to the fibrous cap, compromising the cap and causing rupture. The greater the Brownian motion in the lipid pool, the lower the "viscosity" of the pool, and the more likely the plaque will rupture.
15 Assessing Brownian motion in the lipid pool and measuring the thickness of the fibrous cap *in vivo*, therefore, helps to identify plaques likely to rupture, allowing intervention.

II. Speckle Image Formation

Referring to Fig. 1, a specially modified optical catheter 10 includes a rotatable
20 inner shaft 12 and a transparent outer sheath 14. The inner shaft 12 houses a fiber array 15 and a mirror 16 near its distal end 18. A central fiber 20 in the fiber array connects to a fixed optical fiber 21 that extends from the catheter proximally to a light source 22.

In operation, coherent light, such as laser light, from light source 22 is transmitted
25 via beam-splitter 22a, through the fixed optical fiber 21 and central fiber 20 and onto center 23 of mirror 16. From mirror 16, the light is reflected to a tissue sample 24, such as a layer of static tissue over a layer of moving tissue, such as an atherosclerotic plaque. Outer sheath 14 can be placed directly in contact with sample 24 (near field), or can be positioned a short distance, e.g., 1 mm to 10 cm away from the sample (far field). Light enters sample 24, where it is reflected by molecules, cellular debris, proteins, compounds
30 (e.g., cholesterol crystals), and cellular microstructures (such as organelles, microtubules) within the sample. Light remitted from the sample (arrows 26) reflects from mirror 16 to the fibers of array 15, and is then transmitted by array 15 to a planar charge-coupled device (CCD), or a linear or two-dimensional detector 22b, via a beam-splitter 22a, e.g.,

5 located within light source 22. There may be one or multiple fibers for detection and illumination and detection may occur from the same fiber. Alternatively, illumination may occur through a fiber array where each fiber is selectively illuminated to generate multiple speckle patterns as a function of position on the sample. This method can provide a scanning of the incident light across a sample while keeping the probe
10 stationary by illuminating one fiber after another in series.

Due to interference, a speckle pattern forms at the CCD detector. The resulting speckle pattern is then digitized by an analog-digital converter, and analyzed using the procedures described in the analysis section below.

The entire shaft 12 can rotate 360 degrees in the direction of arrow R, allowing
15 catheter 10 to gather images around the entire circumference of a sample. For example, catheter 10 can gather images of a plaque around the circumference of a vessel wall.

Since only a few fibers are required to gather adequate speckle data, the diameter of the catheter can be less than 500 μm . Larger diameters are also possible.

Many other types of instruments can be used to gather speckle data. For example,
20 the optics of catheter 10 can be integrated into other types of instruments, such as endoscopes or laparoscopes. The optics can also form a stand-alone unit passed into the accessory port of standard endoscopes or laparoscopes, or integrated into another type of catheter, such as dual-purpose intravascular ultrasound catheter.

The optics can also include a lens that focuses the remitted light 26 onto the distal
25 ends of the fibers in array 15. The lens would allow formation of a "near field image" (near the sample sight less than one wavelength) rather than a "far field image" (at the detector set more than a wavelength away from the surface of the tissue).

The catheter can include a polarization filter to remove all but a certain type of polarized light. For example, a cross-polarized filter would allow only light having a
30 polarization perpendicular to the incident light to reach the detector, while a parallel polarized filter would allow only light having the same polarization as the incident light to pass. Since multiply scattered light is less likely to retain its initial polarization than single scattered light, polarization filters can be used to bias the data toward multiply

5 scattered or single scattered light. Such bias can be used to deduce information about the structure of the sample, since light which has penetrated deeper into the sample will be more highly scattered than light reflected from the surface or remitted from near the surface.

10 Instead of a CCD, the detector can be, e.g., a photographic plate, an array of photodetectors, or a single detector. The light source can illuminate the sample with continuous light or synchronized pulses.

15 Rather than transmitting the light to the sample through optical fibers, it is also possible to shine light onto a sample in free space. For example, in an open surgical procedure, coherent light in free space could be directed onto a sample with mirrors, and the remitted light then directed to a fiber array. In such free space embodiments, the light source can be, e.g., as far as one meter, or more, away from the sample.

III. Isolation of Microscopic Motion

20 To simplify determining the viscosity of a moving tissue or liquid (e.g., a plaque's lipid pool) under a static tissue (e.g., a plaque cap) from changes in a speckle pattern, the temporal changes in the pattern should indicate movement of reflectors within the plaque, but not indicate movement of the plaque itself or movement of reflectors between the detector and the plaque. In other words, the changes in the plaque's speckle pattern preferably reflect microscopic or Brownian motion, but not macroscopic motion.

25 To isolate microscopic motion, data is gathered: (1) at time intervals sufficient to detect microscopic motion; and (2) in a manner that compensates for macroscopic (e.g., extrinsic) motion.

30 For a time interval to be sufficient to detect microscopic Brownian motion, the interval must be long enough to allow for movement of reflectors in the tissue, such as a lipid pool, but short enough that the random Brownian movements do not cancel out. For atherosclerotic plaque, an appropriate time interval is about 1-200 ms. Shorter time periods may also be possible. If the time intervals are longer, then changes in the speckle

5 pattern may not adequately differentiate rapid Brownian movement (indicating low
viscosity) from slower Brownian movement (indicating high viscosity).

In the atherosclerotic plaque and other examples, two common sources of
macroscopic motion are gross movement of the vessel lumen and plaque tissue due to
heartbeats, and blood flow between the plaque and the catheter. Patient movement can
10 also be an issue.

To compensate for gross motion of a target tissue (e.g., a plaque) due to
heartbeats, at least two alternatives are possible. First, the fiber array 15 can be coupled
to the plaque tissue using, e.g., an angioplasty balloon. This technique also compensates
for minor patient movements. Referring to Fig. 2A, in one embodiment, a balloon 28 is
15 attached to outer sheath 14, on a far side 30 of the catheter. Once the catheter is
positioned within a blood vessel in proximity to the plaque, the balloon is inflated.
Referring to Fig. 2B, the inflated balloon abuts the vessel wall 32, and presses the
catheter against plaque 24, such that a distal region of outer shaft 14 is in direct contact
with the plaque. With the catheter coupled to plaque 24 as shown in Fig. 2B, fiber array
20 15 will move with the plaque when the heart beats, and the gross motion of the plaque
will not significantly affect the speckle pattern.

Other methods of coupling the catheter to the plaque are also possible. For
example, instead of placing the balloon to the side of the catheter, the balloon can
surround the catheter. In this arrangement, a transparent balloon surrounds outer sheath
25 14, but is also attached to the sheath. When the balloon is inflated, the balloon is
squeezed between plaque 24 and wall 32 of the vessel. The balloon, therefore will be in
direct contact with the plaque, and will move with the plaque when the heart beats. Since
the balloon is attached to shaft 14, and shaft 14 is coupled to array 15, movement of the
vessel wall will not significantly affect the speckle pattern. Additional methods of
30 coupling the catheter to tissue can also be used, including methods that do not employ an
angioplasty balloon.

A second method of compensating for movement caused by heartbeats is to gather
data between heartbeats. In this method, data is gathered during the relatively still PR

5 interval of the diastole of the heartbeat (when the left ventricle is filling with blood). The PR interval lasts for about 0.12-0.2 seconds, providing sufficient time to detect Brownian motion. To insure that data is gathered during diastole, the timing can be computer-controlled or the detector can be linked to an ECG signal, and programmed to gather data only during the PR interval. Similar techniques can be used to compensate for other
10 bodily movements such as peristalsis.

To compensate for blood flow between the catheter and the plaque, the catheter can be placed in direct contact with the plaque tissue, as described above, thereby preventing blood from flowing between the detector and the plaque. Alternatively, blood flowing between the plaque and the catheter can be removed and replaced with clear
15 saline solution or other clear solutions such as optically transparent blood substitutes.

Finally, rather than compensating for macroscopic motion while gathering data, one can compensate for this motion during the analysis phase by mathematically excluding the macroscopic (extrinsic) motion from the analysis, as described below.

20 IV. Analysis of Speckle Data

Fig. 3 illustrates a typical speckle pattern 40 formed by reflecting light from the wall of a healthy blood vessel. X and Y coordinates overlay pattern 40 to facilitate mathematical description of the pattern. The pattern includes dark patches, where destructive interference dominates, and brighter patches, where constructive interference
25 dominates. Very subtle movements of reflectors within the multiply scattering sample alter the speckle pattern.

By analyzing a series of speckle patterns formed from light reflected from a plaque, one can estimate: (a) the viscosity of a plaque's lipid pool; and (b) the thickness of plaque's fibrous cap. From either or both of these types of data, the plaque's
30 vulnerability to rupture can be assessed.

5 A. Determining Viscosity of a Plaque's Lipid Pool

 There are a number of methods of analyzing speckle data to determine the viscosity of a plaque's lipid pool. By way of example, one method is described in detail in this section and in the Example section below. This method includes: (1) gathering a series of speckle images at short, discrete time intervals; (2) eliminating diffuse
10 reflectance from the data; (3) creating cross-correlation images comparing the speckle images in the series; (4) calculating the maximum correlation between each pair of images to create a one-dimensional data set over time; (5) calculating the rate of decorrelation from the data set; and (6) from the rate of decorrelation, assessing the plaque's viscosity and vulnerability to rupture.

15 First, using the detection system described above, a series of speckle images are gathered for a plaque at discrete intervals over a period of time. For example, speckle images can be gathered, e.g., at intervals of every 1, 5, 10, 20, or 30 ms for a time period of, e.g., 200 ms. In general, the shorter the time intervals, the shorter the time period over which data can be gathered. For longer time intervals, such as 30 ms, data can be
20 gathered for, e.g., 1-2 seconds.

 Second, to isolate the speckle pattern, the background, non-coherent diffuse reflectance is eliminated from the images. A number of techniques can be used to eliminate the tissue's diffuse reflectance. For example, the raw data speckle images can be converted to edge images. Edge images are spatial derivatives of the raw data images;
25 an edge image (high pass filter) reflects the change in intensity of an image as a function of space, at all points in the image, rather than the intensity itself. Known techniques of edge detection include convolution of the image by a kernel (e.g., Sobel or Robert), Morph gradient (subtraction of an eroded, dilated, closed, or opened image by its original), or high pass filtering. Other methods of eliminating background diffuse
30 reflectance include homomorphic filtering, local histogram equalization, or using an optical setup with a small aperture. All of these techniques are well known, and are described, e.g., in Gonzalez, R.C. and Wintz, P., "Digital Image Processing" (Addison-

5 Wesley Publishing Company, Reading MA, 1987) and Jain, Anil, K., "Fundamentals of Digital Image Processing" (Prentice Hall, Englewood Cliffs, NJ, 1987).

After eliminating the non-coherent background reflectance, each speckle image (or edge image) is compared to a reference image in the series (e.g., the $t = 0$ image) to create a series of cross-correlation images. The cross-correlation images reflect the
 10 degree of correlation between the two images as a function of space. From each cross-correlation image, the maximum correlation peak (i.e., the amount of correlation at the point of maximum correlation) is determined using the equation:

$$g(t) = \max \left[\iint I(x, y, 0) I(x + x', y + y', t) dx' dy' \right] \quad (1)$$

15

where $g(t)$ is the cross-correlation function, $I(x, y)$ is intensity of the interference at a point (x, y) in the pattern, and t is time. Two-dimensional cross-correlation functions are described generally in Jae S. Lim, "Two-Dimensional Signal Processing" (Prentice Hall, Englewood Cliffs, NJ, 1990) and Jain, Anil, K., "Fundamentals of Digital Image
 20 Processing" (Prentice Hall, Englewood Cliffs, NJ, 1987).

By performing the maximum correlation calculations, the cross-correlation images are reduced to a one-dimensional data set as a function of time (i.e., a series of correlation values, each value associated with a time t). From this series of correlation values, a time constant, τ , is calculated, where τ represents the rate of decorrelation. The
 25 time constant is the amount of time it takes $g(t)$ to reach $(1/e)g(0)$.

The max function of equation (1) is not the only possible mechanism for reducing the cross-correlation images to a number. For example, image comparisons can be reduced to a representative value by evaluating the cross-correlation function:

$$g(x, y, t) = \iint I(x, y, 0) I(x + x', y + y', t) dx' dy' \quad (2)$$

at a point, such as $x = y = 0$. However, using a point to reduce the image to a value, rather than a max function, would not compensate for the "memory effect" of first order

5 correlation of speckle patterns in turbid media. This “memory effect” is described in
Feng et al., Science 251: 633-39 (1991). Advantages to using a point are that a minimum
number of fibers and detectors can be used.

From the rate of decorrelation, represented by time constant τ , the viscosity of the
plaque’s lipid pool can be assessed. In general, the larger τ , the lower the Brownian
10 motion in the lipid pool, and the greater the pool’s viscosity. On the other hand, the
smaller τ , the greater the Brownian motion in the lipid pool, and the lower the viscosity.
The lower the viscosity, the more stresses are exerted on the cap, making the plaque more
vulnerable

This information, the viscosity of the plaque’s lipid pool, can be used to identify
15 plaques likely or vulnerable to rupture. Specifically, if τ is about 40-100 ms or lower,
then the plaque is likely to rupture, and intervention is warranted. If the plaque τ is about
100-200 ms, then the plaque is somewhat vulnerable, but not yet likely to rupture, and
should be monitored over time. If the plaque τ is about 200-300 ms, then the plaque is
less vulnerable. Non-plaque covered, healthy vessel wall generally has a time constant
20 greater than 300 ms or 500 ms.

B. Determining Thickness of a Tissue Structure Such as a Plaque’s Fibrous Cap

In addition to determining the viscosity of the lipid pool in the plaque, the speckle
data can be analyzed to deduce spatial characteristics of the plaque, including the
25 thickness of the fibrous cap, or the thickness of any tissue structure or tissue layer for that
matter. As discussed above, a thin fibrous cap is another indication that a plaque is
vulnerable to rupture. The combination of data relating to viscosity and cap thickness
provides the most accurate assessment of plaque vulnerability, although the two
characteristics can be assessed and analyzed independently.

30 Referring to Fig. 4, a typical plaque 50 includes a fibrous cap 52 and a lipid pool
54. Photons that enter plaque 50 (arrow A) are internally scattered by reflectors within
the plaque, such as collagen in fibrous cap 52 and lipids in pool 54. The various photons,
therefore, exit the plaque at different locations (arrows B). As a result, the speckle

5 pattern (see Fig. 2) has a diameter considerably larger than the width of the original light beam.

The thickness of fibrous cap 52 can be deduced by comparing different regions of the resulting speckle pattern. Referring again to Fig. 3, light forming intensity signals in the outer portion 60 of the pattern traveled greater distances than light forming signals
 10 near the center 62 of the pattern. Thus, outer portion 60 of the pattern is formed by photons that, on average, penetrated deeper into the plaque than photons forming center 62. By calculating separate time constants for separate regions of the speckle pattern, the viscosity of the plaque at different depths can be determined. Since the fibrous cap generally exhibits less Brownian motion than the lipid pool, the thickness of the fibrous
 15 cap can be estimated from spatially dependent data.

To estimate the thickness of the fibrous cap, separate max cross-correlation functions are described for separate, small regions of the pattern. Each region is defined by a window, w , centered at (x_0, y_0) :

$$g(x_0, y_0, t) = \max \left[\iint w(x' - x_0, y' - y_0) I(x, y, 0) I(x + x', y + y', t) dx' dy' \right] \quad (3)$$

Time constants are then calculated from the cross-correlation data for each window, in the manner described above. The variation of τ as a function of the distance from the center of the speckle pattern (i.e., as a function of $(x_0^2 + y_0^2)^{1/2}$) can then be
 25 analyzed to determine the thickness of the fibrous cap. Plaque cap thickness of less than about 60 μm is considered to be vulnerable, but this number can vary to some extent depending on the specific patient.

In general, the thickness of any tissue structure, e.g., a tissue layer that overlies or is adjacent to a different tissue, e.g., a plaque fibrous cap over a lipid pool, can be
 30 measured using the following algorithm:

1. Measure the decorrelation time constant τ as a function of $r = (x_0^2 + y_0^2)^{1/2}$
2. Measure the optical properties (e.g., effective attenuation coefficient μ_{eff}) of the tissue layer by computing the first and second order statistics of a speckle probability

5 distribution function (PDF)(histogram), or by using diffuse reflectance spectrophotometry.

3. Compare $\tau(r)$ and the optical properties (e.g., μ_{eff}) to previously computed Monte Carlo or Diffusion theory simulations of $\tau(r)$ and μ_{eff} as a function of tissue layer thickness. Alternatively, if r_0 is defined as the cutoff between static and non-stationary
10 speckle, r_0 and μ_{eff} may be used as inputs to a look-up table containing tissue layer thickness values.

C. Mathematical Compensation for Macroscopic Motion

In addition to providing information about the structural features of a tissue such
15 as a plaque, separately analyzing different regions of a speckle pattern also allows decorrelation caused by macroscopic motion to be identified and removed from the analysis. In general, macroscopic motion caused by gross movement of the plaque tissue or blood flow will be directional, non-random, and global. By contrast, Brownian motion will be non-directional and non-uniform (or random). Thus, by calculating separate
20 decorrelation functions for different regions of the speckle pattern, decorrelation due to extrinsic motion can be identified and subtracted from the functions, allowing isolation of random, Brownian motion. For example, the position of maximums of cross-correlation functions will shift along a vector \vec{v} , which relates extrinsic motion of the sample with respect to the catheter or detection. Brownian motion will decorrelate the speckle
25 patterns in many random directions, and will result in a broadening of the cross-correlation peak and a decrease in correlation maximum above that predicted by linear motion. These two behaviors for intrinsic and extrinsic linear motion should be separable from the cross-correlation function.

V. Additional Imaging Methods

In a simplified system, the rate of decorrelation can be estimated from single pixel speckle images, rather than full, two-dimensional speckle patterns. In this system, a catheter with a single optical fiber could transmit data to a single detector, such as a

5 photodiode. The speckle data gathered would be intensity at the spot as a function of time. From this data, a rate of decorrelation can be calculated directly or only as a function of time as opposed to space, without any spatial cross-correlation analysis.

Imaging methods that detect single scattered light, such as optical coherence tomography (OCT) and confocal microscopy, can also be used. While these imaging
10 methods are less sensitive to speckle modulation than the multiple scattering methods described above, they have the advantage of allowing localization of data to a single point within the sample. Such localization would allow measurement of biomechanical properties of the tissue in three dimensions. In addition, in methods that use heterodyne detection, such as OCT, motion of the scatterers can produce a Doppler shift on the
15 returned light. The Doppler shift can provide a further basis for measuring viscosity in the sample. For Brownian motion the velocities would be distributed over a range of velocities and directions causing multiple Doppler shifts and a broadening of the frequency bandwidth distribution. The mathematics for OCT and confocal microscopy based imaging techniques would be substantially similar to the mathematics described
20 above.

EXAMPLE

In this example, speckle images formed by reflecting laser light from a cadaveric atherosclerotic plaque in a human aorta were analyzed to assess the plaque's viscosity. A portion of normal aorta was also analyzed for comparison.

25 At a temperature of 37°C, light from a helium-neon laser ($\lambda = 632.8$ nm) was shined on a cadaveric aortic plaque for two seconds. Light reflected from the plaque was received at a CCD camera with a shutter speed of 30 frames per second, through a cross-polarization filter. During the two seconds, the CCD camera recorded a series of 60 speckle images at intervals of 33 ms. Three of the 60 raw data images, corresponding to
30 times $t = 0$, $t = 150$ ms, and $t = 300$ ms, are shown in row A of Fig. 5.

Using IPLab® Spectrum® imaging software, edge detection was performed on the 60 raw speckle images, generating 60 edge images. The three edge images for times $t = 0$, $t = 150$ ms, and $t = 300$ ms are shown in row B of Fig. 5. As discussed above, the

5 edge images reflect the spatial derivative of the raw speckle images (i.e., the light patches in the edge images of row B are locations where the intensity is changing as a function of space).

Using the same software, each of the 60 edge images was then compared to the $t = 0$ edge image 70 to form 60 cross-correlation images. Each cross-correlation image
10 was generated by multiplying the Fourier transform of the reference image 70 by the complex conjugate of the Fourier transform of the image in question, and then calculating an inverse Fourier transform of the product. For example, referring to row C of Fig. 5, image 72 is an autocorrelation of the $t = 0$ edge image. Image 72 was formed by multiplying the Fourier transform of reference image 70 by the complex conjugate of the
15 Fourier transform of image 70, and then calculating the inverse Fourier transform of the product. Image 74 was formed by multiplying the Fourier transform of image 70 by the complex conjugate of the Fourier transform of the $t = 150$ ms edge image, and then calculating the inverse Fourier transform of the product.

Each cross-correlation image represents the degree of correlation between the
20 corresponding edge image and the reference edge image 70 (i.e., brighter spots are locations where there is a higher degree of correlation than at darker spots).

From each cross-correlation image, the maximum cross-correlation peak (i.e., the correlation at the maximum point of correlation) was calculated using equation (1). The resulting data set included 60 cross-correlation values, each value associated with a time
25 t .

A set of images of normal aorta tissue is shown in Fig. 6. These images are comparable to the set of images in Fig. 5 for a lipid-rich plaque in the same aorta and were imaged and processed in the same manner.

The maximum cross-correlation data for the lipid-rich plaque and the normal
30 aorta tissue were then fit to an exponential cross-correlation function, $G(\tau)$, using Igor Pro®, v 3.01 software (Wavemetrics, Inc). The resulting exponential function was graphed in Fig. 7, curve 80. By way of comparison, the exponential cross-correlation function for speckle data taken from healthy cadaveric aortic tissue is shown in curve 82.

5 The data for curve 82 was gathered and processed using the same procedures as the data for curve 80. Fig. 7 also shows the data for a thick-capped plaque (curve 81). The time constant for this non-vulnerable plaque was 400 ms, so the plaque would not need intervention. Again, the same techniques were used to generate this curve as curves 80 and 82.

10 From the cross-correlation data, the decorrelation rate, represented by the time constant τ , was calculated. For the plaque, the time constant was 40 ms. For the aortic tissue, the time constant was 500 ms.

Based on these data, the plaque was borderline vulnerable. Thus, had this plaque been analyzed *in vivo*, using the procedures described above, a physician would have
15 determined that the plaque was a possible candidate for rupture, and may have chosen to intervene, preventing a possible infarction.

OTHER EMBODIMENTS

As noted throughout, the methods described herein can also be used to
20 characterize diseased tissue other than atherosclerotic plaques. The microscopic and macroscopic constituents of diseased tissue differ from normal non-pathologic counterparts. For example, speckle patterns can be used to diagnose and characterize other tissue pathology such as neoplasia (cancer), infection, tissue viability, or healing response to injury. In the case of neoplasia, tumors typically have an abnormal
25 abundance of one cell type (clonal) and a surrounding abnormal supporting matrix. This cell type may produce and secrete a viscous fluid, such as mucin in adenocarcinoma, which would result in lower speckle decorrelation time constants than normal non-cancerous tissue. Moreover, the surrounding matrix may be composed of necrotic tissue and an abundance of abnormal vessels that would also serve to decrease the speckle
30 decorrelation time constant. Other tumors, like osteosarcoma, produce osteoid or immature bone that would increase the time constant compared to normal tissue. Other forms of neoplasia would have increased time constants due to desmoplastic (abundant) fibrous stroma initiated by cytokines produced by the tumor. Indeed, many tumors,

5 including bronchogenic carcinomas and breast carcinomas are firm upon gross examination due to the fibrous stroma surrounding the malignant cells. This fibrous stroma would increase the time constant relative to surrounding normal tissue.

In other examples, in the case of infection, abscesses will be less viscous than surrounding tissue, enabling identification of the infected region by measuring a decrease
10 in the time constant. Inflammation, manifested by the influx of activated inflammatory cells will be characterized by a decrease in the speckle decorrelation time constant as these cells degrade the normal supporting tissue in response to a the presence of bacterial, viral, or foreign body antigens. Necrotic tissue, such as burn eschar, diabetic ulcers, necrotic bowel, and ischemic myocardium will have longer time constants than viable
15 tissue from the same organ due to the lack of intravascular and extravascular fluid and flow in these extracellular spaces.

In the case of healing, fibrosis and fibrous remodeling will likely have longer time constants due to the abundance of collagen matrix and granulation tissue, which would not be present in uninjured tissue. Speckle decorrelation times may also be used to
20 estimate tissue hydration and provide a means for quantifying the state of hydration in a patient. While the above examples elucidate some of the mechanisms that explain how disease affects the biomechanical properties of pathologic tissue, many more exist and are well known in the field of gross anatomic pathology. These differing biomechanical properties and characteristics can be measured by speckle for the purpose of screening,
25 intraoperative margin (e.g., tumor margin) identification, and primary diagnosis.

The foregoing detailed description is intended to illustrate and not limit the scope of the invention, which is defined by the appended claims. Other aspects, advantages, and modifications are within the scope of the claims.

What is claimed is:

1. A method of analyzing tissue, the method comprising:
illuminating a tissue with coherent or partially coherent light;
receiving light reflected from the tissue at a detector to form a series of speckle patterns; and
analyzing changes in the speckle patterns at time intervals sufficient to measure changes caused by microscopic motion of objects within the tissue.
2. The method of claim 1, wherein the microscopic motion is Brownian motion.
3. The method of claim 1, wherein the microscopic motion is motion of cells or cellular organelles.
4. The method of claim 1, further comprising compensating for macroscopic motion to isolate the microscopic motion.
5. The method of claim 1, wherein the tissue is *in vivo*.
6. The method of claim 1, wherein the tissue is internal tissue.
7. The method of claim 6, wherein the illuminating step comprises providing an invasive device coupled to a light source, passing the device into a patient, placing the device in proximity to the tissue, and shining coherent or partially coherent light from the light source onto the tissue.
8. The method of claim 7, wherein the invasive device is selected from the group consisting of a catheter, an endoscope, and a laparoscope.
9. The method of claim 7, wherein the placing step includes placing the device in direct contact with the tissue.

10. The method of claim 1, wherein the coherent light comprises laser light.
11. The method of claim 1, wherein the partially coherent light comprises light from a superluminescent diode.
12. The method of claim 1, wherein the detector is located farther than one wavelength of light from the tissue and detects far field speckle.
13. The method of claim 1, wherein the detector is located within one wavelength of light from the tissue and detects near field speckle.
14. The method of claim 1, wherein the analyzing step comprises comparing each of the series of speckle patterns to a series of reference speckle patterns, and quantifying the temporal correlation differences between the speckle patterns and the reference patterns.
15. The method of claim 14, wherein the analyzing step comprises digitizing each of the speckle patterns, and the quantifying step comprises evaluating a cross-correlation between the speckle patterns and the reference patterns.
16. The method of claim 14, wherein the analyzing step comprises digitizing each of the speckle patterns, and the quantifying step comprises evaluating a maximum cross-correlation between the speckle patterns and the reference patterns.
17. The method of claim 15, wherein the analyzing step further comprises determining a decorrelation rate for the speckle patterns.
18. The method of claim 1, wherein the analyzing step further comprises analyzing spatial characteristics of the speckle pattern to deduce structural characteristics of the tissue.
19. The method of claim 1, wherein the analyzing step further comprises analyzing spatial characteristics of the speckle pattern to deduce biomechanical characteristics of the tissue.

20. The method of claim 18, wherein the illuminating step comprises illuminating multiple locations of the tissue in succession, the receiving step comprises forming a separate series of speckle patterns for each respective section of the tissue, and the analyzing step comprises analyzing each separate series of speckle patterns and comparing the separate series to deduce structural differences between the respective locations of the tissue.

21. The method of claim 4, wherein compensating for macroscopic motion comprises performing the receiving step during a diastole of a heartbeat.

22. The method of claim 4, wherein macroscopic motion comprises patient motion.

23. The method of claim 4, wherein the macroscopic motion is peristalsis.

24. The method of claim 4, wherein receiving comprises gathering reflected light at a light receptor and transmitting the gathered light to the detector, and wherein compensating for macroscopic motion includes coupling the receptor to the tissue.

25. The method of claim 4, wherein compensating for macroscopic motion includes excluding changes in the speckle patterns caused by non-random motion during the analysis step.

26. The method of claim 4, wherein macroscopic motion results from blood flow between the tissue and the reflector, and the compensating step comprises replacing the blood with a transparent solution.

27. The method of claim 1, wherein the tissue comprises an atherosclerotic plaque

28. The method of claim 1, wherein the tissue comprises a tumor, a tumor margin, necrotic tissue, ischemic tissue, or damaged tissue.

29. A method of determining the susceptibility to rupture of an atherosclerotic plaque having a lipid pool and a fibrous cap, the method comprising:

illuminating the plaque with coherent or partially coherent light;

receiving light reflected from the plaque at a detector to form a series of speckle patterns;

gathering speckle pattern data at time intervals sufficient to measure microscopic motion within the lipid pool; and

assessing the plaque's vulnerability to rupture from the amount of microscopic motion.

30. The method of claim 29, further comprising analyzing spatial characteristics of the speckle pattern data to deduce structural characteristics of the plaque.

31. The method of claim 30, wherein analyzing comprises assessing the thickness of the fibrous cap.

32. The method of claim 31, wherein cap thickness is assessed by

(i) measuring the decorrelation time constant τ as a function of $r = (x_0^2 + y_0^2)^{1/2}$;

(ii) measuring optical properties of the cap; and

(iii) comparing the measured optical properties and $\tau(r)$ to a mathematical simulation that models light remittance as a function of cap layer thickness.

33. The method of claim 32, wherein the optical properties are measured by computing first and second order statistics of a speckle probability distribution function or by using diffuse reflectance spectrophotometry.

34. The method of claim 32, wherein the mathematical simulation is a Monte Carlo simulation or diffusion theory simulation.

35. The method of claim 31, wherein a plaque is considered vulnerable to rupture if the thickness of the fibrous cap is less than about 60 microns.

36. The method of claim 30, wherein analyzing comprises assessing the viscosity of the lipid pool.

37. The method of claim 36, wherein the plaque is considered vulnerable to rupture if the viscosity of the lipid pool has a time constant of less than about 200 milliseconds.

38. The method of claim 36, wherein the plaque is considered likely to rupture if the viscosity of the lipid pool has a time constant of less than about 100 milliseconds.

39. A method of analyzing a tissue structure, the method comprising:
illuminating the tissue structure with coherent or partially coherent light;
receiving light reflected from the tissue structure at a detector to form a series of speckle patterns;
gathering speckle pattern data at time intervals sufficient to measure microscopic motion within the tissue structure or adjacent tissue; and
assessing the tissue structure by analyzing spatial characteristics of the speckle pattern data to deduce structural or biomechanical characteristics of the tissue structure.

40. The method of claim 39, wherein analyzing comprises assessing the thickness of the tissue structure.

41. The method of claim 40, wherein tissue structure thickness is assessed by
(i) measuring the decorrelation time constant τ as a function of $r = (x_0^2 + y_0^2)^{1/2}$;
(ii) measuring optical properties of the tissue structure; and
(iii) comparing the measured optical properties and $\tau(r)$ to a mathematical simulation that models light remittance as a function of tissue structure thickness.

42. The method of claim 41, wherein the optical properties are measured by computing first and second order statistics of a speckle probability distribution function or by using diffuse reflectance spectrophotometry.

43. The method of claim 41, wherein the mathematical simulation is a Monte Carlo simulation or diffusion theory simulation.

44. A method of detecting a vulnerable atherosclerotic plaque having a lipid pool and a fibrous cap within a blood vessel, the method comprising:

illuminating a segment of the blood vessel *in vivo* with coherent or partially coherent light;

receiving light reflected from the interior vessel wall of the segment at a detector to form a series of speckle patterns;

gathering speckle pattern data at time intervals sufficient to measure microscopic motion within the interior vessel wall; and

comparing speckle pattern time constants to a known speckle pattern time constant for a normal blood vessel and a known speckle pattern time constant for an atherosclerotic plaque;

wherein speckle pattern time data corresponding to a speckle pattern time constant for an atherosclerotic plaque indicates the segment of the blood vessel contains a vulnerable atherosclerotic plaque.

45. The method of claim 44, further comprising analyzing spatial characteristics of the speckle pattern data to determine structural characteristics of the plaque.

46. The method of claim 45, wherein analyzing comprises assessing the thickness of the fibrous cap.

47. The method of claim 46, wherein a plaque is considered vulnerable to rupture if the thickness of the fibrous cap is less than about 60 microns.

48. The method of claim 46, wherein analyzing comprises assessing the viscosity of the lipid pool.

49. The method of claim 45, wherein the plaque is considered vulnerable to rupture if the viscosity of the lipid pool has a time constant of less than about 200 milliseconds.

50. The method of claim 49, wherein the plaque is considered likely to rupture if the viscosity of the lipid pool has a time constant of less than about 100 milliseconds.

51. A fiber optic probe for detecting speckle patterns in a sample, the probe comprising

a catheter including a rotatable inner shaft and a transparent outer sheath;

a fiber array housed within the shaft and comprising one or more first optical fibers for transmitting incident light to the sample and one or more second optical fibers for transmitting light remitted from the sample; and

a mirror arranged near a distal end of the shaft to reflect light passing through the fiber array onto a sample outside the transparent outer sheath and back from the sample through the fiber array.

52. The fiber optic probe of claim 51, wherein the shaft can rotate 360 degrees within the sheath.

53. The fiber optic probe of claim 51, wherein the fiber array comprises a single first optical fiber for transmitting incident light to the sample.

54. The fiber optic probe of claim 51, wherein the fiber array comprises multiple first optical fibers for transmitting incident light to the sample.

55. The fiber optic probe of claim 51, wherein the fiber array comprises a single second optical fiber for transmitting light remitted from the sample.

56. The fiber optic probe of claim 51, wherein the one or more fibers selected to transmit incident light are the same as the one or more fibers selected to transmit remitted light.

57. The fiber optic probe of claim 51, wherein one fiber of the array is selected as the first optical fiber to transmit incident light to the sample, and thereafter a different fiber is

selected as the first optical fiber to transmit incident light to the sample, thereby scanning light across the sample.

58. The fiber optic probe of claim 51, further comprising an inflatable balloon connected to the sheath.

59. An optical system for detecting speckle patterns in a sample, the system comprising

a fiber optic probe of claim 51;

a coherent or partially light source connected to an optical fiber within the fiber array;

a detector to receive light remitted from the sample; and

a processor to process the remitted light and to analyze speckle patterns remitted from the sample.

60. The system of claim 59, wherein the processor comprises a reference speckle pattern.

61. The system of claim 59, wherein the processor comprises an analog-digital converter to convert the analog remitted light into a digital signal.

Fig. 1

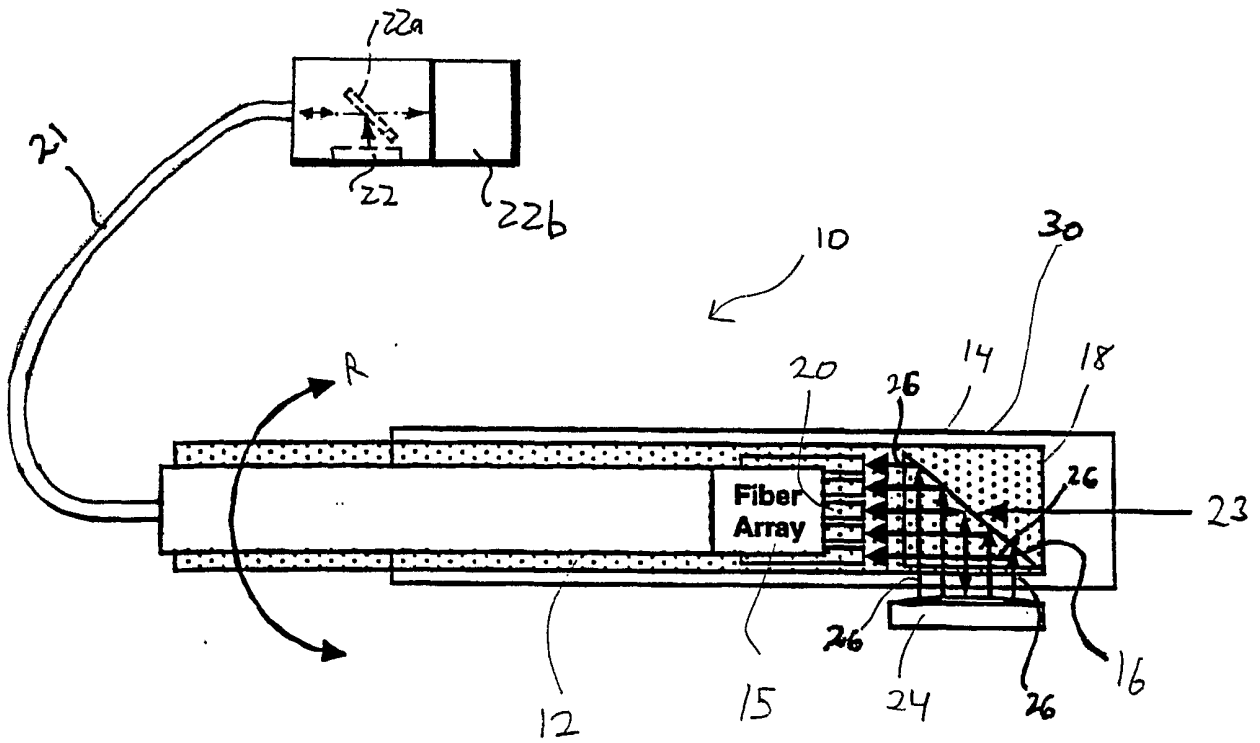

Fig. 2A

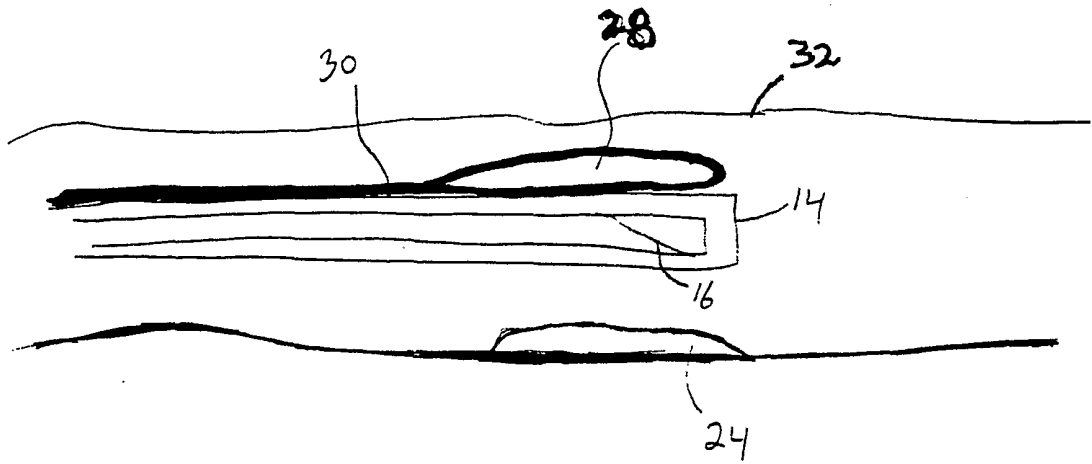

Fig. 2B

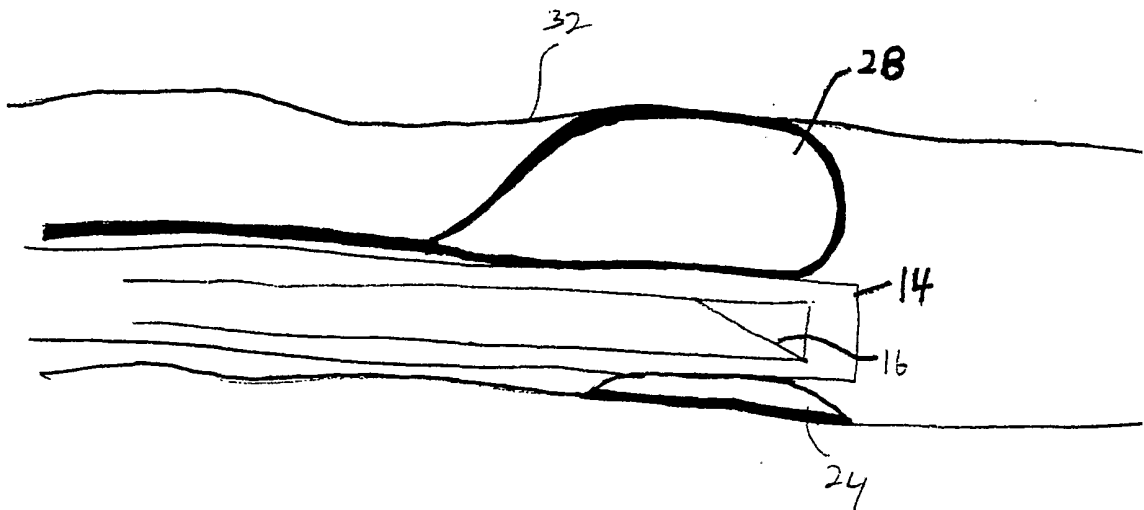

Figure 3

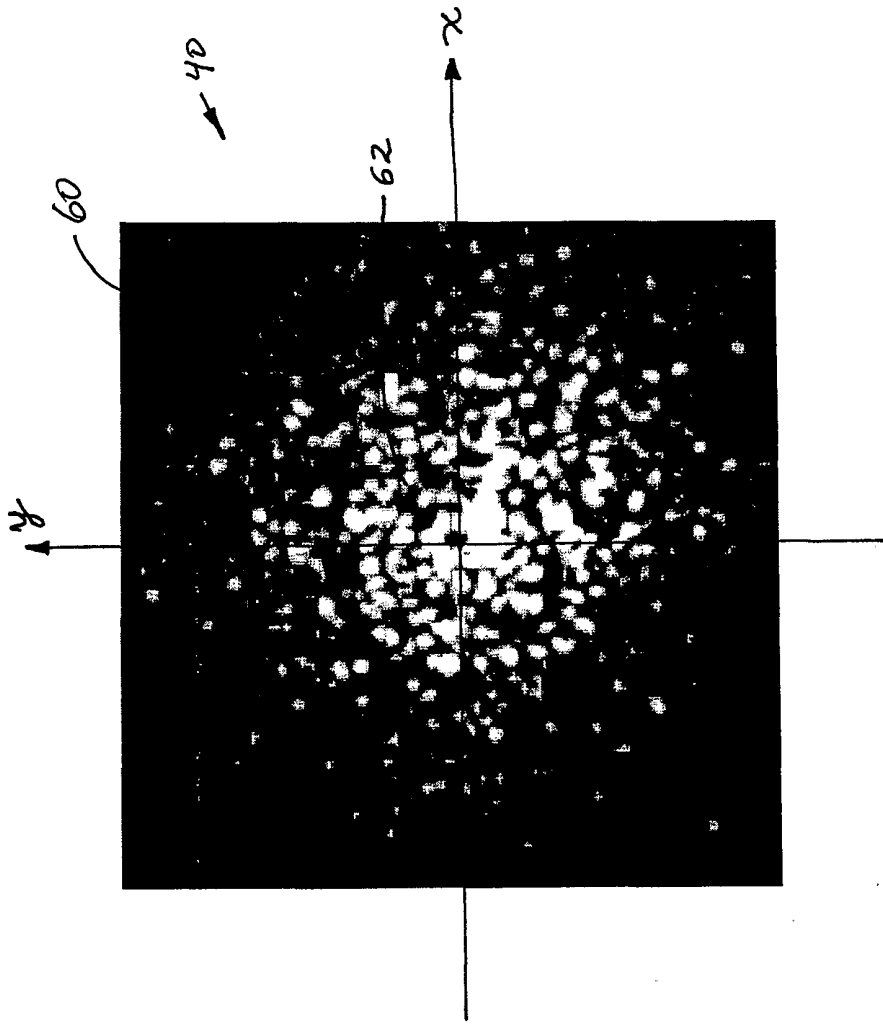
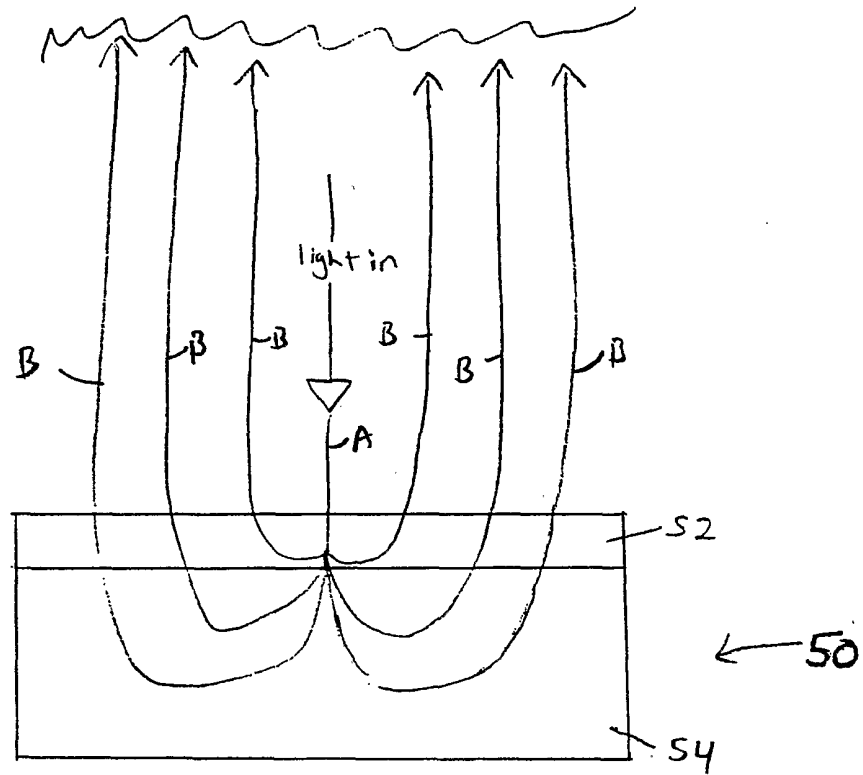
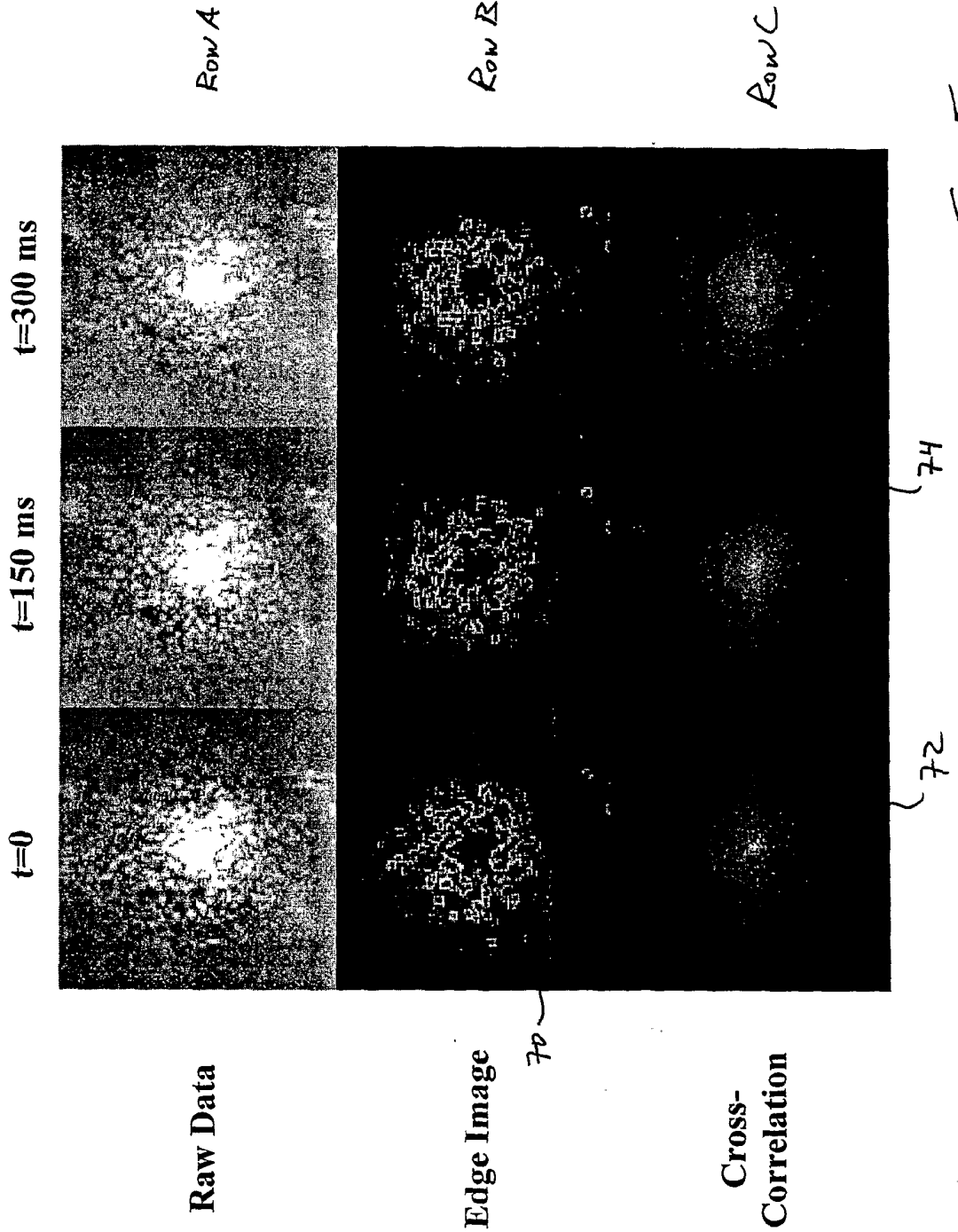

Fig. 4



Lipid-rich plaque



Normal Aorta

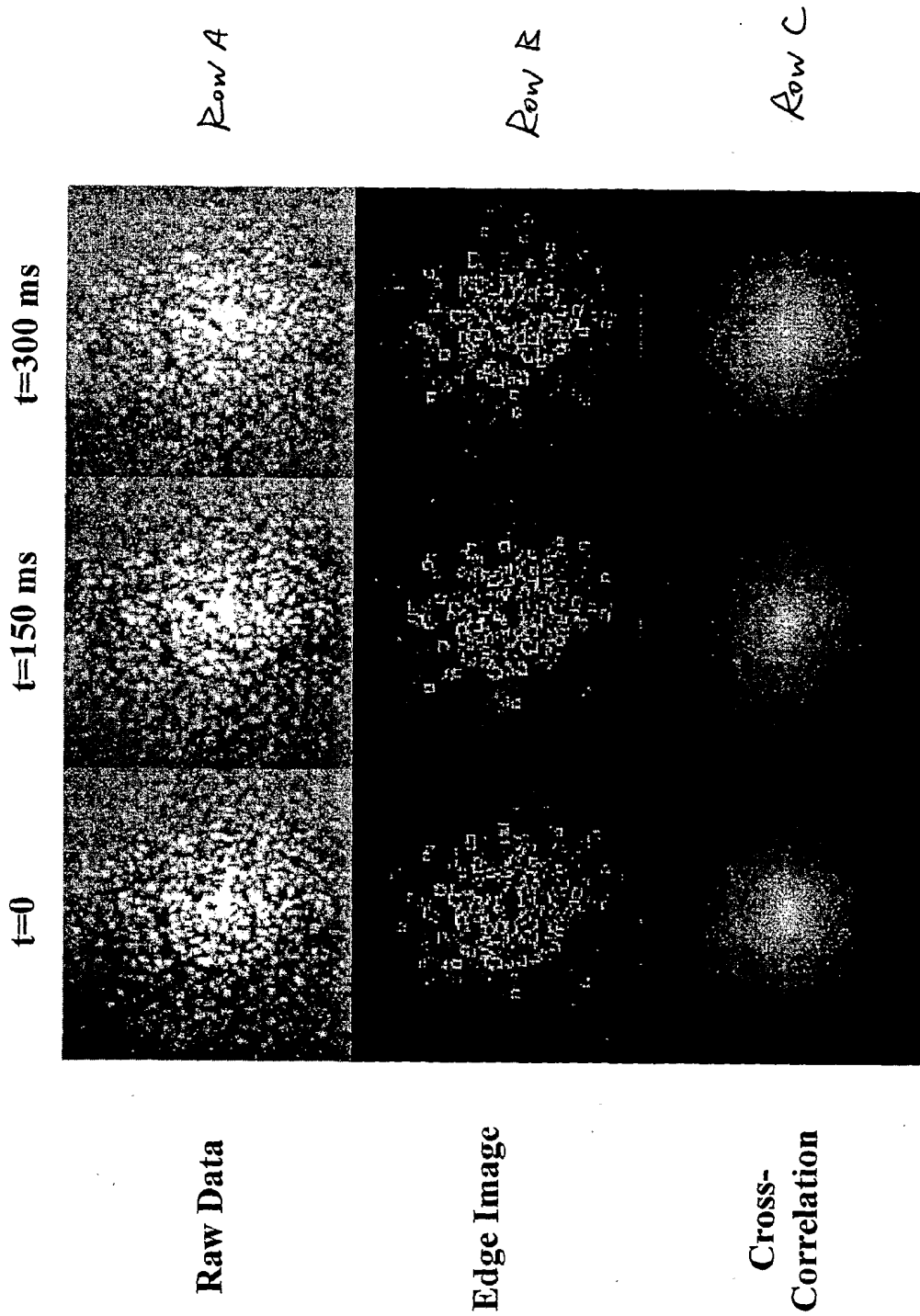
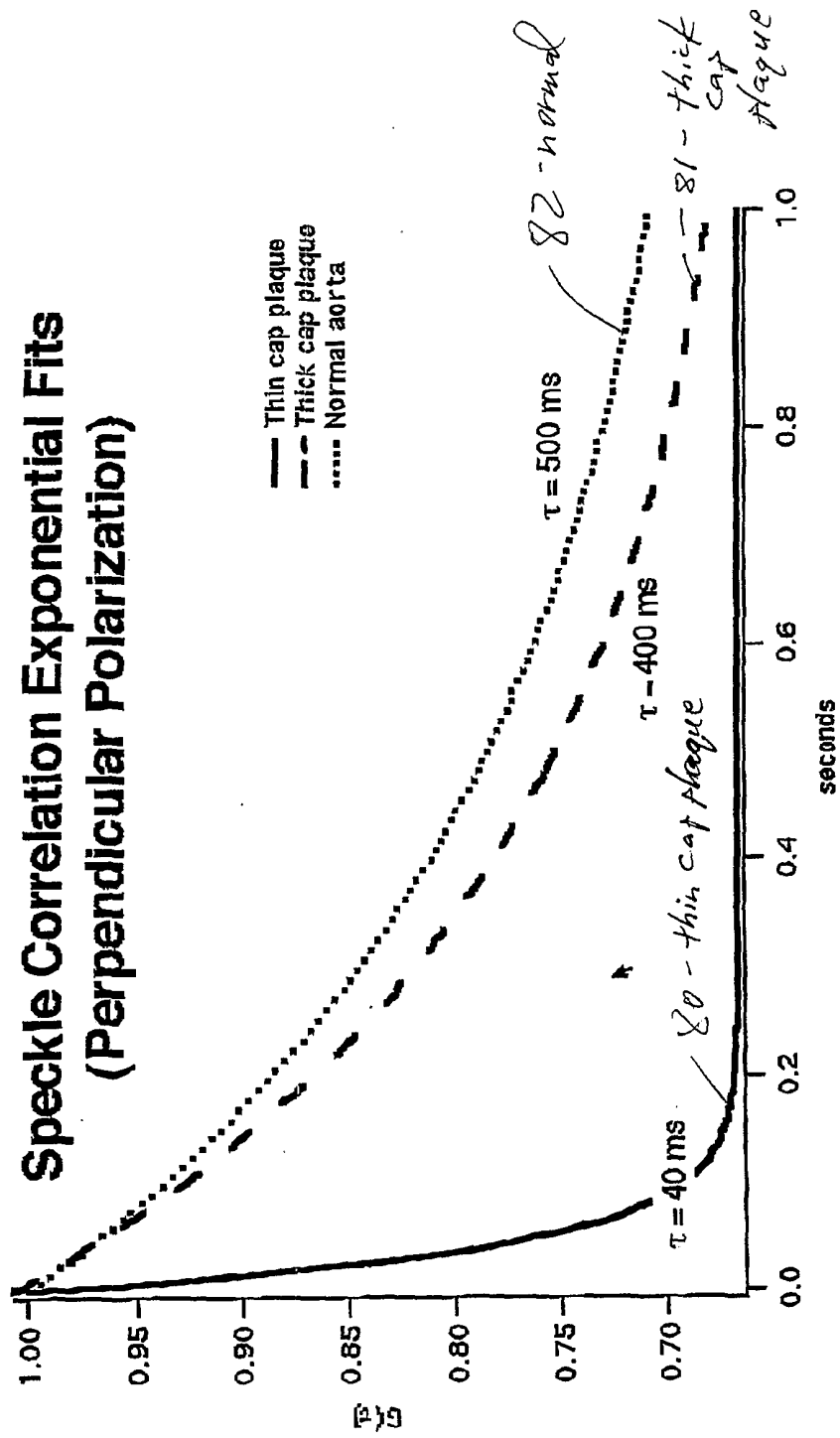

Fig. 6

Figure 7



INTERNATIONAL SEARCH REPORT

International application No.

PCT/US01/48332

A. CLASSIFICATION OF SUBJECT MATTER												
IPC(7) : A61B 8/00 US CL : 600/437, 453												
According to International Patent Classification (IPC) or to both national classification and IPC												
B. FIELDS SEARCHED												
Minimum documentation searched (classification system followed by classification symbols) U.S. : 600/437, 453												
Documentation searched other than minimum documentation to the extent that such documents are included in the fields searched												
Electronic data base consulted during the international search (name of data base and, where practicable, search terms used) EAST												
C. DOCUMENTS CONSIDERED TO BE RELEVANT												
Category *	Citation of document, with indication, where appropriate, of the relevant passages	Relevant to claim No.										
A	US 5,293,873 A (FANG) 15 March 1994, see entire document.	1-50										
---		-----										
Y		51-61										
Y	US 5,291,885 A (TANIJI et al) 08 March 1994, see entire document.	51-61										
<input type="checkbox"/> Further documents are listed in the continuation of Box C. <input type="checkbox"/> See patent family annex.												
<p>* Special categories of cited documents:</p> <table border="0"> <tr> <td>"A" document defining the general state of the art which is not considered to be of particular relevance</td> <td>"T" later document published after the international filing date or priority date and not in conflict with the application but cited to understand the principle or theory underlying the invention</td> </tr> <tr> <td>"E" earlier application or patent published on or after the international filing date</td> <td>"X" document of particular relevance; the claimed invention cannot be considered novel or cannot be considered to involve an inventive step when the document is taken alone</td> </tr> <tr> <td>"L" document which may throw doubts on priority claim(s) or which is cited to establish the publication date of another citation or other special reason (as specified)</td> <td>"Y" document of particular relevance; the claimed invention cannot be considered to involve an inventive step when the document is combined with one or more other such documents, such combination being obvious to a person skilled in the art</td> </tr> <tr> <td>"O" document referring to an oral disclosure, use, exhibition or other means</td> <td>"&" document member of the same patent family</td> </tr> <tr> <td>"P" document published prior to the international filing date but later than the priority date claimed</td> <td></td> </tr> </table>			"A" document defining the general state of the art which is not considered to be of particular relevance	"T" later document published after the international filing date or priority date and not in conflict with the application but cited to understand the principle or theory underlying the invention	"E" earlier application or patent published on or after the international filing date	"X" document of particular relevance; the claimed invention cannot be considered novel or cannot be considered to involve an inventive step when the document is taken alone	"L" document which may throw doubts on priority claim(s) or which is cited to establish the publication date of another citation or other special reason (as specified)	"Y" document of particular relevance; the claimed invention cannot be considered to involve an inventive step when the document is combined with one or more other such documents, such combination being obvious to a person skilled in the art	"O" document referring to an oral disclosure, use, exhibition or other means	"&" document member of the same patent family	"P" document published prior to the international filing date but later than the priority date claimed	
"A" document defining the general state of the art which is not considered to be of particular relevance	"T" later document published after the international filing date or priority date and not in conflict with the application but cited to understand the principle or theory underlying the invention											
"E" earlier application or patent published on or after the international filing date	"X" document of particular relevance; the claimed invention cannot be considered novel or cannot be considered to involve an inventive step when the document is taken alone											
"L" document which may throw doubts on priority claim(s) or which is cited to establish the publication date of another citation or other special reason (as specified)	"Y" document of particular relevance; the claimed invention cannot be considered to involve an inventive step when the document is combined with one or more other such documents, such combination being obvious to a person skilled in the art											
"O" document referring to an oral disclosure, use, exhibition or other means	"&" document member of the same patent family											
"P" document published prior to the international filing date but later than the priority date claimed												
Date of the actual completion of the international search 08 March 2002 (08.03.2002)		Date of mailing of the international search report 18 APR 2002										
Name and mailing address of the ISA/US Commissioner of Patents and Trademarks Box PCT Washington, D.C. 20231 Facsimile No. (703)305-3230		Authorized officer <i>Lalene Bell-Harris for</i> L Blaine Lankford Telephone No. ((703) 308-0196										