

(19) World Intellectual Property  
Organization  
International Bureau



(43) International Publication Date  
6 October 2005 (06.10.2005)

PCT

(10) International Publication Number  
**WO 2005/093337 A1**

- (51) International Patent Classification<sup>7</sup>: **F24H 9/12**
- (21) International Application Number:  
PCT/IB2005/000467
- (22) International Filing Date: 21 February 2005 (21.02.2005)
- (25) Filing Language: Italian
- (26) Publication Language: English
- (30) Priority Data:  
AN2004A000010 1 March 2004 (01.03.2004) IT
- (71) Applicant (for all designated States except US): **MERLONI TERMOSANITARI S.P.A.** [IT/IT]; 45, Viale Aristide Merloni, I-60044 Fabriano (IT).
- (72) Inventors; and
- (75) Inventors/Applicants (for US only): **SAMPAOLESI, Roberto** [IT/IT]; Merloni Termosanitari S.P.A., 45, Viale Aristide Merloni, I-60044 Fabriano (IT). **MANCINI, Angelo** [IT/IT]; Merloni Termosanitari S.P.A., 45, Viale Aristide Merloni, I-60044 Fabriano (IT).
- (74) Agent: **PREMRU, Rok**; Mar.Bre S.r.l., 2, Via San Filippo, I-60044 Fabriano (AN) (IT).
- (81) Designated States (unless otherwise indicated, for every kind of national protection available): AE, AG, AL, AM, AT, AU, AZ, BA, BB, BG, BR, BW, BY, BZ, CA, CH, CN, CO, CR, CU, CZ, DE, DK, DM, DZ, EC, EE, EG, ES, FI, GB, GD, GE, GH, GM, HR, HU, ID, IL, IN, IS, JP, KE, KG, KP, KR, KZ, LC, LK, LR, LS, LT, LU, LV, MA, MD, MG, MK, MN, MW, MX, MZ, NA, NI, NO, NZ, OM, PG, PH, PL, PT, RO, RU, SC, SD, SE, SG, SK, SL, SM, SY, TJ, TM, TN, TR, TT, TZ, UA, UG, US, UZ, VC, VN, YU, ZA, ZM, ZW.
- (84) Designated States (unless otherwise indicated, for every kind of regional protection available): ARIPO (BW, GH, GM, KE, LS, MW, MZ, NA, SD, SL, SZ, TZ, UG, ZM, ZW), Eurasian (AM, AZ, BY, KG, KZ, MD, RU, TJ, TM), European (AT, BE, BG, CH, CY, CZ, DE, DK, EE, ES, FI, FR, GB, GR, HU, IE, IS, IT, LT, LU, MC, NL, PL, PT, RO, SE, SI, SK, TR), OAPI (BF, BJ, CF, CG, CI, CM, GA, GN, GQ, GW, ML, MR, NE, SN, TD, TG).
- Published:**  
— with international search report
- For two-letter codes and other abbreviations, refer to the "Guidance Notes on Codes and Abbreviations" appearing at the beginning of each regular issue of the PCT Gazette.

(54) Title: ACCUMULATOR WATER HEATER WITH DEFLECTOR FOR COLD WATER INTAKE

SECTION A-A

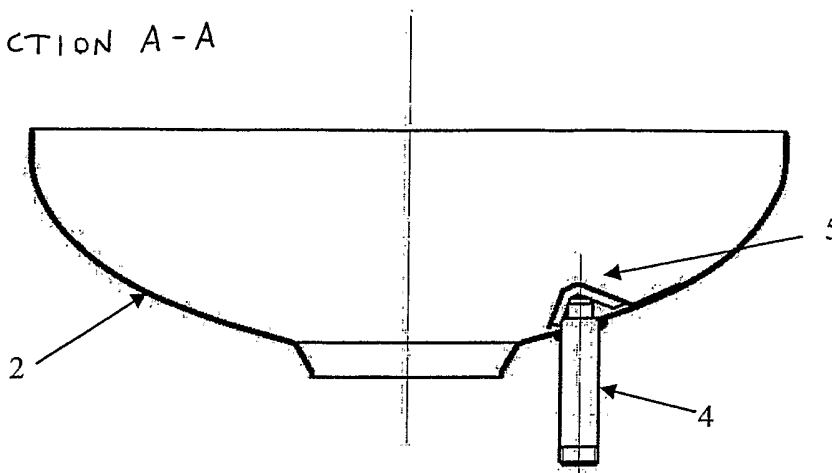

(57) Abstract: It is described a cold water inlet deflector (5) in its various variants applied on an accumulator water heater (1), and that deflects the incoming cold water flow as it enters the tank (2) in a horizontal direction. This action is able to reduce or eliminate the negative effects of so-called water "mixing", thus maximising the amount of usable water at the required temperature. The inlet water deflector (5) can be applied directly onto the tank surface (2) or onto the cold-water inlet pipe (4). The deflector (5) can be applied to accumulator water heaters (1) on both horizontal and vertical axes.

WO 2005/093337 A1

## **ACCUMULATOR WATER HEATER WITH DEFLECTOR FOR COLD WATER INTAKE**

### **DESCRIPTION**

The present patent relates to an accumulator water heater with a deflector for cold-water intake.

Accumulator water heaters currently known to the art can be gas or electrically powered.

- 5 These generally comprise a tank, a cold water intake pipe that is inserted in the lower part of the water heater, an outlet pipe for the heated water that should be at a temperature of approximately 40-45° in order to be usable, taken from the uppermost part of the tank.

- Electric water heaters are equipped with a flange mounted with one or more electric  
10 resistances, a thermostat sheath containing one or more temperature sensors, and lastly an anti-corrosion device generally composed of a magnesium anode.

The flange most commonly used is circular in shape and mounted on the exterior of the tank; however, it can often also be oval-shaped and mounted externally or on the surge tank.

- 15 This flange can be removed for maintenance operations.

The electric resistances mounted on the flange are adapted to heat the cold water as it enters, and can be either accordion or spiral type electric resistances in order to obtain a compromise between the need for adequate spiral length and the possibility of insertion and extraction of the flange on which the electric resistance is mounted.

- 20 On the other hand the thermostat sheath contains the temperature sensors.

Said sensors may be electronic, bulb-type, or more commonly, rods composed of two materials with a different thermal dilatation coefficient, generally a brass rod with an invar core, that provides average temperature calculation along the length of the rod. However, the water heaters currently known to the art present several disadvantages.

5 In particular, said water heaters present the well-known problem of so-called "mixing".

The cold water that is introduced into the tank at the time the hot water is removed tends to mix with the water already contained in the tank, provoking a drop in the water temperature lower than that required for normal use.

10 This results in a reduction of the quantity of the water that can be used before heating up, and therefore a reduction in performance and an increase in the delay period before the water is re-heated.

According to known art, the system used to reduce the mixing effect is to introduce the cold water in a direction as horizontal as possible and at very low speed.

15 This tends to create a layer of cold water at the bottom of the tank limiting its mixing with the hot water and trying to prevent any vortex or turbulence.

These systems are partly made possible through the use of deflectors that are positioned above the end of the inlet pipe to prevent the cold water from being introduced in a vertical direction.

20 Generally these deflectors have a spherical or ellipsoid cover shape.

Alternatively, inlet pipes with the end part closed and with side openings for water distribution can also be used.

These systems have not provided satisfactory results by any means.

25 The possible use of a large number of inlet sections and diffusers to distribute the cold water on the bottom surface of the tank is not feasible because of the very high costs involved.

The aim of the present invention is to resolve at least part of the disadvantages in currently known accumulator water heaters, and in particular, those disadvantages described above.

30 This aim is achieved through a water heater compliant with the description in claim 1, or through a deflector compliant with the description in claim 18.

Further advantages can be obtained through the application of the additional characteristics described in the subordinate claims.

A possible embodiment of the present patent, compliant with the claims herein, will be described below with reference to the appended drawings in which:

- 5           - fig.1 is a plane view of the water heater;
- fig. 2 is a cross section of the water heater according to the line A-A in figure 1;
- fig. 3 is a view from above of the deflector according to a first embodiment;
- 10          - fig. 4 is a cross section of the deflector according to the line B-B in figure 3;
- fig. 5 is a cross section of the deflector according to the line A-A in figure 4;
- fig. 6 is a side view of the deflector according to a second embodiment;
- 15          - fig. 7 is a cross section of the deflector according to a third embodiment according to the line A-A;
- fig. 8 is a cross section of the deflector according to the line B-B in figure 7.

20   Throughout, the reference numeral 1 in the drawings indicates an accumulator water heater comprising a tank 2, equipped with a closure element 3, a cold-water inlet pipe 4, and a hot water outlet pipe 6.

In the case of electric water heaters, the closing element 3 is composed of a flange mounted with heating means, such as electric resistances, means for controlling the accumulated water temperature, and anti-corrosion means.

25   Flange 3 may be circular and mounted externally, or as in this case, it can be oval and mounted on the surge tank.

The inlet pipe 4 introduces the cold water into the lower part of tank 2.

30   Preferably, the outlet pipe 6 enters the lower part of the tank and terminates at the upper end to take in the water heated to the required user temperature.

A deflector 5 is set over the inlet pipe to deflect the cold-water flow in a horizontal

direction as it enters the tank.

According to a first embodiment shown in figures 3, 4, and 5, the deflector 5 has a “roof tile” shape.

5 More precisely the deflector 5 has a first surface 11 slanting in an upwards direction, a second section 12, practically horizontal, and a third surface 13 slanting downwards.

The deflector also has a fin 14, preferably less wide than the other surfaces, that extends in a practically horizontal direction to enable the deflector to be anchored to the bottom of tank 2, most commonly by welding.

10 The deflector 5 is therefore fixed to the water heater tank 2, by the fin 14, so that the surfaces that form the characteristic “roof tile” structure are positioned over the cold water inlet pipe 4.

When the deflector is welded to the tank, the free edge of surface 11 is set adjacent to the surface of tank 2.

15 The deflector 5 also has two side edges 15 adjacent to the surfaces 11, 12 and 13, slanting downwards and with chamfered edges.

The said side edges 15 reinforce the structure providing the deflector 5 with extra rigidity and resistance.

20 According to a second embodiment of the finding shown in figure 6, the deflector 5 has the form of the external surface of a half-cylinder.

According to a third embodiment shown in figure 7, the deflector 5 is fixed directly to the inlet pipe 4 by means of an insert 16 having a width approximately equal to the internal diameter of pipe 4, to provide anchoring through shrink fitting on the inlet pipe 4.

25 The water entering the tank separated by insert 16 is deflected sideways by two surfaces 17 very similar to the external surface of a half cylinder with a radius which increases as it extends outwards from the insert 16.

In the third embodiment, the deflector 5 is preferable manufactured from moulded plastic material.

30 According to another embodiment, the deflector 5 shown in figure 7 can also be fixed to the tank by means of a fin 14 similar to that described in the first two

embodiments.

In this case the deflector is preferably manufactured from moulded sheet metal.

The cold-water flow is prevented from moving in a vertical direction inside the tank 2, by the deflector 5, thus limiting the distribution to the bottom of the tank because  
5 of the predominantly horizontal water flow.

This contributes towards maximizing the amount of usable water at the required temperature by reducing the negative "mixing" effects.

In the embodiments described above, the deflector 5 can be applied to both vertical and horizontal axis water heaters, and therefore can be mounted both on the top  
10 cover of the tank as well as on the screw attachment of the tank.

Preferably the width of deflector 5, and therefore the section inside which the water is "directed" horizontally is approximately twice the size of the inlet pipe 4 diameter.

Preferably the distance between the outlet opening and the deflector surface of deflector 5 is approximately equal to half the diameter of the inlet pipe 4.

**CLAIMS**

- Claim 1. Accumulator water heater (1), comprising a tank (2) equipped with
- a cold water inlet pipe (4) adapted to introduce water into the lower part of the tank (2),
  - 5 – a deflector (5) positioned over said inlet pipe (4) adapted to deflect the incoming water flow direction,
  - an outlet pipe for hot water (6) adapted to take up the water from the top part of said tank (2),
- characterised in that said incoming water deflector (5) is adapted to deflect
- 10 the inlet water flow in a basically horizontal direction.
- Claim 2. Accumulator water heater (1), according to claim 1, characterised in that said incoming water deflector (5) has a “roof tile” form.
- Claim 3. Accumulator water heater (1), according to claim 2, characterised in that
- 15 said incoming water deflector (5) has a first surface slanting in an upwards direction (11), a second horizontal surface (12) and a third surface slanting in a downwards direction (13).
- Claim 4. Accumulator water heater (1), according to claim 3, characterised in that said incoming water deflector (5) has two side edges (15) slanting in a downward direction.
- 20 Claim 5. Accumulator water heater (1), according to claims 3 or 4, characterised in that the free edge of said first slanting surface (11) is adjacent to the internal surface of the said tank (2).
- Claim 6. Accumulator water heater (1), according to claim 1, characterised in that
- 25 said incoming water deflector (5) has the form of the external surface of a half-cylinder.
- Claim 7. Accumulator water heater (1), according to any one of the previous claims, characterised in that said incoming water deflector (5) has a fin (14) adapted to be welded to the surface of said tank (2).
- Claim 8. Accumulator water heater (1), according to claim 1, characterised in that
- 30 said incoming water deflector (5) has two sides that are generally similar to the external surfaces of a half cylinder (17) with a radius that increases at it

extends outwards from the centre of said inlet pipe (4).

- 5 Claim 9. Accumulator water heater (1), according to claim 8, characterised in that said incoming water deflector (5) has an insert (16) having a width that is generally and/or basically equal to the internal diameter of the cold water inlet pipe (4) to fix the deflector (5) to the inlet water pipe (4).
- Claim 10. Accumulator water heater (1), according to claims 8 or 9, characterised in that said incoming water deflector (5) is manufactured from a moulded plastic material.
- 10 Claim 11. Accumulator water heater (1), according to claim 8, characterised in that said incoming water deflector (5) has a fin (14) adapted to be welded to the surface of said tank (2).
- Claim 12. Accumulator water heater (1), according to claim 11, characterised in that said incoming water deflector (5) is manufactured from moulded metal sheeting.
- 15 Claim 13. Accumulator water heater (1), according to one of the previous claims, characterised in that said incoming water deflector (5) is anchored to the top cover of said tank (2) of said water heater (1) in a vertical axis.
- Claim 14. Accumulator water heater (1), according to one of the previous claims, characterised in that said incoming water deflector (5) is anchored to the screw attachment of said tank (2) of said water heater (1) in a horizontal axis.
- 20 Claim 15. Accumulator water heater (1), according to one of the previous claims, characterised in that the distance between the end of the said inlet pipe (4) and the surface of said deflector (5) is generally and/or basically equal to half of the diameter of said inlet pipe (4).
- 25 Claim 16. Accumulator water heater (1), according to one of the previous claims, characterised in that the width of said deflector (5) is equal to twice the diameter of said inlet pipe (4).
- Claim 17. Incoming cold water deflector (5) for an accumulator water heater adapted to deflect the inlet water flow in a basically horizontal direction.
- 30 Claim 18. Incoming cold water deflector (5) for an accumulator water heater

according to claim 17, characterised in that it has a "roof tile" shape.

5 Claim 19. Incoming cold water deflector (5) for an accumulator water heater according to claim 18, characterised in that it has a first side slanting in an upwards direction (11) a second horizontal section (12) and a third surface slanting in a downwards direction (13).

Claim 20. Incoming cold water deflector (5) for an accumulator water heater according to claims 18 or 19, characterised in that it has two side edges (15) slanting in a downwards direction.

10 Claim 21. Incoming cold water deflector (5) for an accumulator water heater according to claim 17, characterised in that it has the shape of the external surface of a half cylinder.

15 Claim 22. Incoming cold-water deflector (5) for an accumulator water heater according to any one of the claims between 17 and 21, characterised in that it has a fin (14) that extends in a direction that is generally and/or basically horizontal.

20 Claim 23. Incoming cold water deflector (5) for an accumulator water heater according to claim 17, characterised in that has two surfaces that are practically similar to the external surface of a half cylinder (17), with a radius that increases as it extends outwards from the centre of said inlet pipe (4).

Claim 24. Incoming cold water deflector (5) for an accumulator water heater according to claim 23, characterised in that it has an insert (16) that extends in a direction perpendicular to the axis of the half-cylinder surfaces.

25 Claim 25. Incoming cold-water deflector (5) for an accumulator water heater according to claims 23 or 24, characterised in that it is manufactured from moulded plastic material.

30 Claim 26. Incoming cold water deflector (5) for an accumulator water heater according to claim 23, characterised in that it has a fin (14) that extends in a generally and/or basically horizontal direction.

Claim 27. Incoming cold-water deflector (5) for an accumulator water heater

according to the previous claims, characterised in that it is manufactured from moulded metal plate.

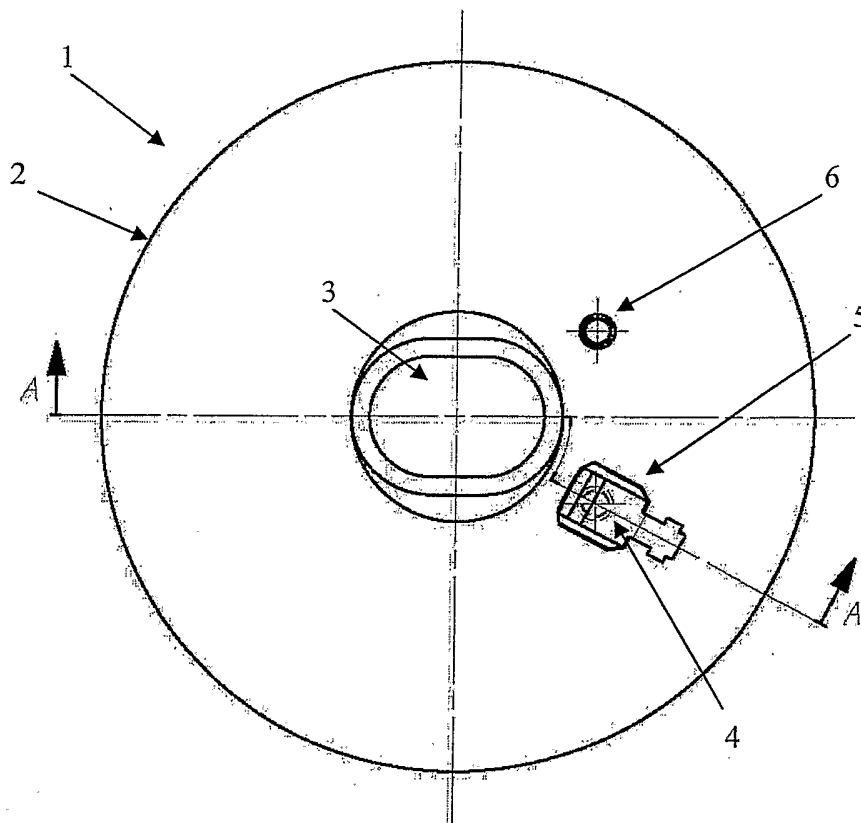

Fig. 1

SECTION A-A

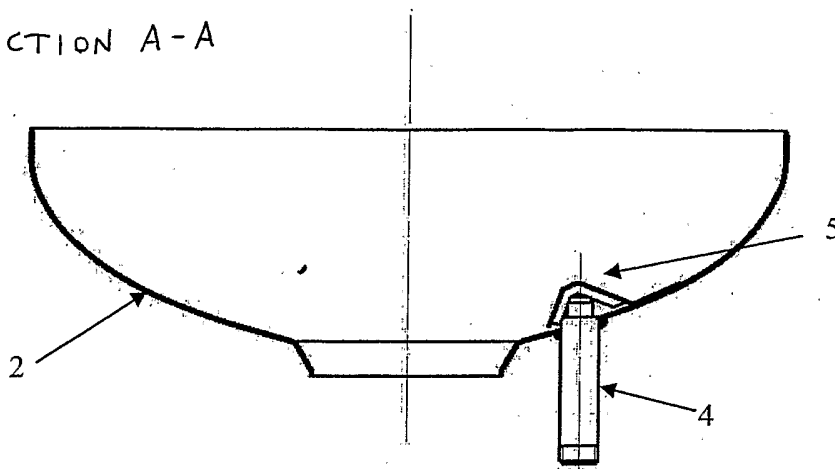

Fig. 2

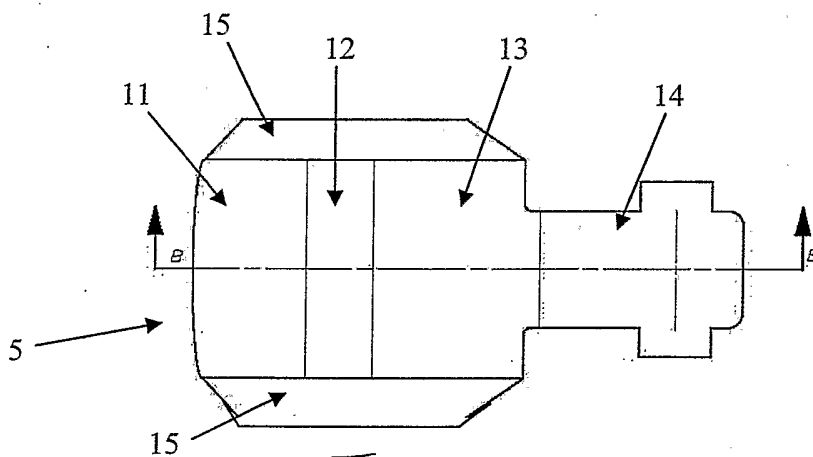

Fig. 3

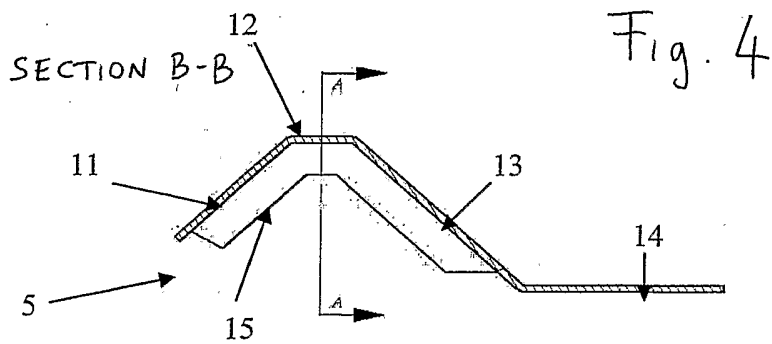

Fig. 4

SECTION A-A

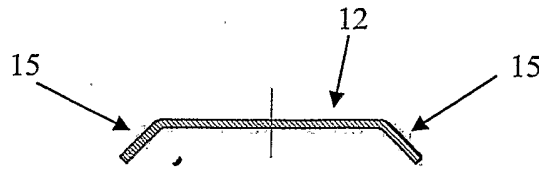

Fig. 5

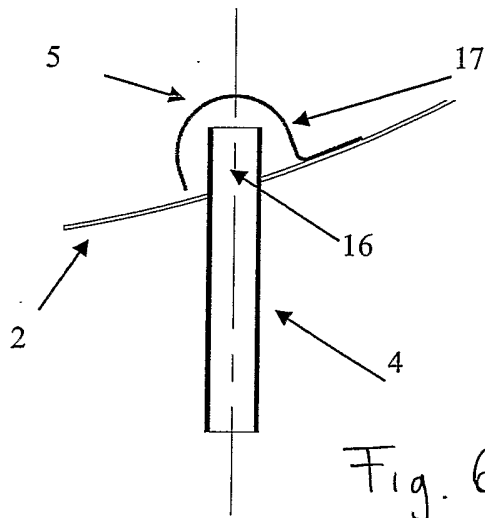

Fig. 6

Fig. 7

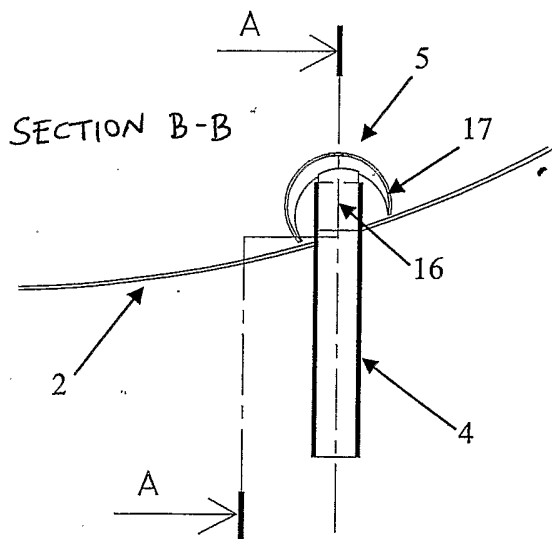
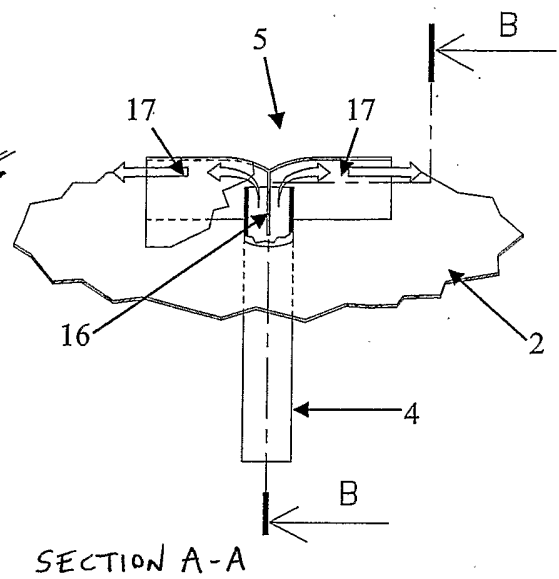

Fig. 8



## INTERNATIONAL SEARCH REPORT

Int Application No  
PCT/IB2005/000467

A. CLASSIFICATION OF SUBJECT MATTER  
IPC 7 F24H9/12

According to International Patent Classification (IPC) or to both national classification and IPC

## B. FIELDS SEARCHED

Minimum documentation searched (classification system followed by classification symbols)  
IPC 7 F24H F28D F28F

Documentation searched other than minimum documentation to the extent that such documents are included in the fields searched

Electronic data base consulted during the international search (name of data base and, where practical, search terms used)

EPO-Internal

## C. DOCUMENTS CONSIDERED TO BE RELEVANT

Category °	Citation of document, with indication, where appropriate, of the relevant passages	Relevant to claim No.
X	US 6 510 819 B1 (POLLOCK F. MARTIN ET AL) 28 January 2003 (2003-01-28) column 3, line 37 - column 4, line 52; figures 1,5,8,9	1-5, 13-22
X	GB 479 609 A (THE GENERAL ELECTRIC COMPANY LIMITED; RICHARD HARVEY; ERIC JOHN BARNES) 9 February 1938 (1938-02-09)	1-5,7, 13-22
Y	the whole document	6
X	DE 625 026 C (AKTIEBOLAGET CTC) 1 February 1936 (1936-02-01)	17-27
Y	the whole document	6

Further documents are listed in the continuation of box C.

Patent family members are listed in annex.

° Special categories of cited documents :

"A" document defining the general state of the art which is not considered to be of particular relevance  
"E" earlier document but published on or after the international filing date  
"L" document which may throw doubts on priority claim(s) or which is cited to establish the publication date of another citation or other special reason (as specified)  
"O" document referring to an oral disclosure, use, exhibition or other means  
"P" document published prior to the international filing date but later than the priority date claimed

"T" later document published after the international filing date or priority date and not in conflict with the application but cited to understand the principle or theory underlying the invention  
"X" document of particular relevance; the claimed invention cannot be considered novel or cannot be considered to involve an inventive step when the document is taken alone  
"Y" document of particular relevance; the claimed invention cannot be considered to involve an inventive step when the document is combined with one or more other such documents, such combination being obvious to a person skilled in the art.  
"&" document member of the same patent family

Date of the actual completion of the international search

15 June 2005

Date of mailing of the international search report

29/06/2005

Name and mailing address of the ISA

European Patent Office, P.B. 5818 Patentlaan 2  
NL - 2280 HV Rijswijk  
Tel. (+31-70) 340-2040, Tx. 31 651 epo nl,  
Fax: (+31-70) 340-3016

Authorized officer

Arndt, M

# INTERNATIONAL SEARCH REPORT

Information on patent family members

Inter al Application No PCT/IB2005/000467
---

Patent document cited in search report	Publication date	Publication date	Patent family member(s)	Publication date
US 6510819	B1	28-01-2003	BR 0104277 A	04-06-2002
			CA 2355807 A1	26-03-2002
			JP 2002188862 A	05-07-2002
			MX PA01009691 A	20-08-2002
			TW 533297 B	21-05-2003
GB 479609	A	09-02-1938	NONE	
DE 625026	C	01-02-1936	NONE	