

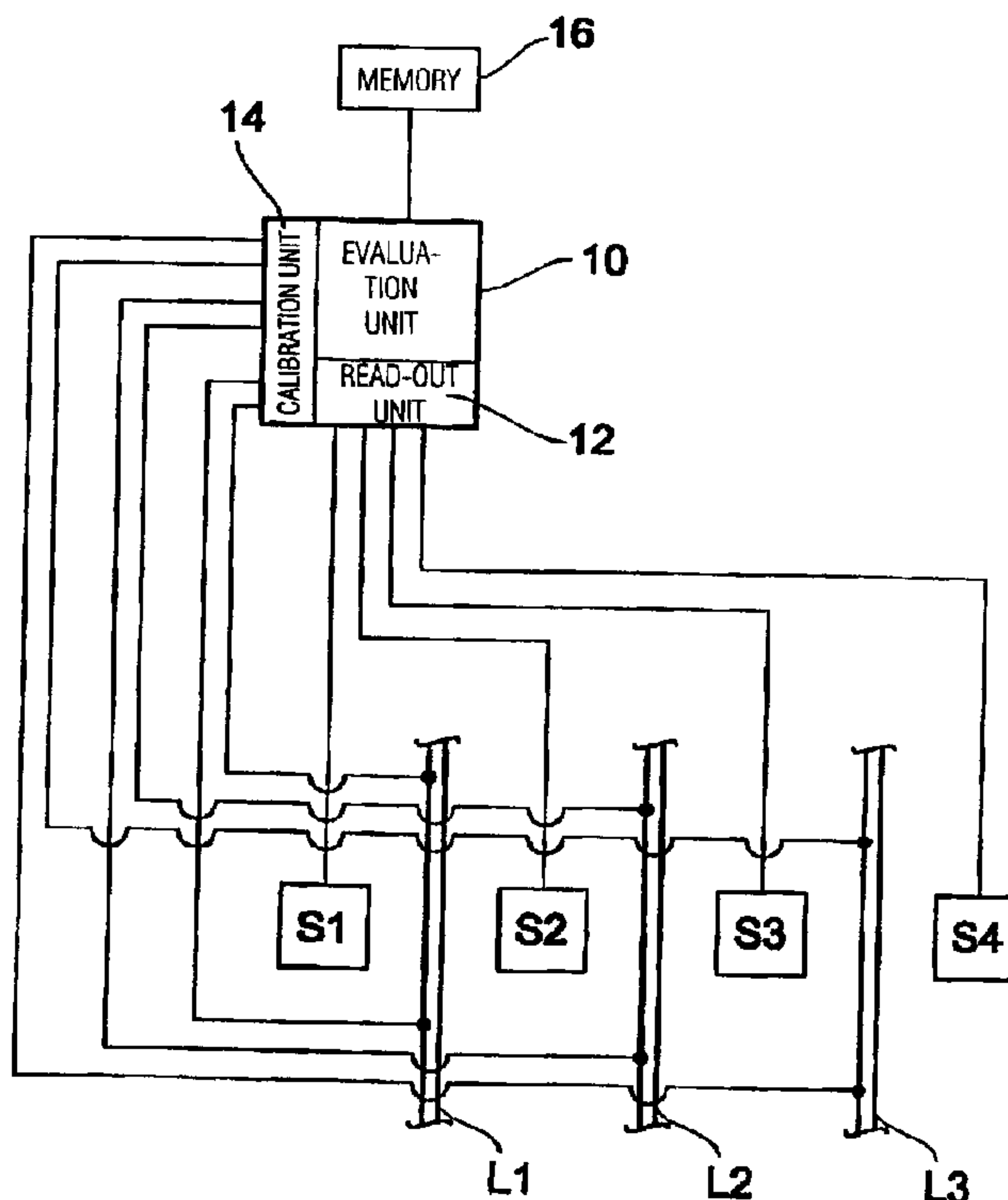

(86) Date de dépôt PCT/PCT Filing Date: 2000/01/17
 (87) Date publication PCT/PCT Publication Date: 2000/09/14
 (45) Date de délivrance/Issue Date: 2006/07/04
 (85) Entrée phase nationale/National Entry: 2001/06/21
 (86) N° demande PCT/PCT Application No.: EP 2000/000316
 (87) N° publication PCT/PCT Publication No.: 2000/054063
 (30) Priorité/Priority: 1999/03/11 (DE199 10 801.3)

(51) Cl.Int./Int.Cl. *G01R 15/24* (2006.01),
G01R 19/00 (2006.01), *G01R 15/20* (2006.01)
 (72) Inventeurs/Inventors:
HOHE, HANS-PETER, DE;
WEBER, NORBERT, DE;
SAUERER, JOSEF, DE
 (73) Propriétaire/Owner:
FRAUNHOFER-GESELLSCHAFT ZUR FORDERUNG
DER ANGEWANDTEN FORSCHUNG E.V., DE
 (74) Agent: MCCARTHY TETRAULT LLP

(54) Titre : DISPOSITIF ET PROCEDE DE MESURE D'INTENSITE
 (54) Title: DEVICE AND METHOD FOR MEASURING AN ELECTRIC CURRENT



(57) **Abrégé/Abstract:**

A current measuring device for measuring the current through one or a plurality of conductors (L1, L2, L3) of an array of n conductors, n being a natural number ≥ 2 , comprises n+1 magnetic-field-sensitive sensors (S1 to S4) which are arranged such that two respective magnetic-field-sensitive sensors are arranged adjacent a respective conductor. A unit (12) for reading out output signals of the magnetic-field-sensitive sensors is provided. Furthermore, the current measuring device is provided with a unit (10) for calculating the current through one or a plurality of conductors on the basis of the read output signals and on the basis of coefficients which describe the influence of currents flowing through each of the n conductors and of a constant magnetic field on the output signal of each of the magnetic-field-sensitive sensors.

Device and Method for Measuring an Electric CurrentAbstract

5

A current measuring device for measuring the current through one or a plurality of conductors (L1, L2, L3) of an array of n conductors, n being a natural number ≥ 2 , comprises n+1 magnetic-field-sensitive sensors (S1 to S4) which are arranged such that two respective magnetic-field-sensitive sensors are arranged adjacent a respective conductor. A unit (12) for reading out output signals of the magnetic-field-sensitive sensors is provided. Furthermore, the current measuring device is provided with a unit (10) for calculating the current through one or a plurality of conductors on the basis of the read output signals and on the basis of coefficients which describe the influence of currents flowing through each of the n conductors and of a constant magnetic field on the output signal of each of the magnetic-field-sensitive sensors.

10
15
20

Device and Method for Measuring an Electric Current

BACKGROUND OF THE INVENTION

5

Field of the Invention

The present invention relates to a device and a method for measuring an electric current and, in particular, to a device and a method for measuring the electric current flowing through one or a plurality of conductors of an array of several electric conductors which are arranged in close proximity to one another.

15

Description of Prior Art

For potential-free current measurement it is known to place two magnetic-field-sensitive sensors on both sides of an electric conductor. Such an arrangement is schematically shown in Fig. 1, where two magnetic-field-sensitive sensors 2 and 4 are arranged on both sides of an electric conductor 6. By means of the magnetic-field-sensitive sensors 2 and 4, the magnetic field generated by a current flowing through the conductor 6 is measured. The current in the conductor is determined by forming the difference between the output signals of the two magnetic-field-sensitive sensors 2 and 4; this principle permits an existing, gradient-free magnetic field to be eliminated when the current is being measured. The above-described arrangement is disadvantageous insofar as $2n$ sensors are required, when the currents in n conductors are to be measured simultaneously. The known method is also problematic when the currents through a plurality of conductors

2

are to be measured and when the conductors are arranged in closely spaced relationship with one another. This will give rise to a magnetic field gradient at the location of a conductor due to the current of a neighbouring conductor so that the current measurement will be disturbed. The influence of the magnetic field gradient caused by the current in the neighbouring conductor cannot be compensated for.

10 SUMMARY OF THE INVENTION

It is the object of the present invention to provide a device and a method for measuring the current through one or a plurality of conductors of an array of n conductors making use of a reduced number of magnetic-field-sensitive sensors, which additionally permit an exact detection of the current through one of the conductors even if the individual conductors of the conductor array are arranged in close proximity to one another.

20 This object is achieved by a current measuring device for measuring the current through one or a plurality of conductors of an array of n conductors, n being a natural number ≥ 2 , in the case of which $n+1$ magnetic-field-sensitive sensors are arranged in such a way that two respective magnetic-field-sensitive sensors are arranged adjacent a respective conductor. Furthermore, a unit for reading out output signals of the magnetic-field-sensitive sensors is provided. Finally, the current measuring device is provided with a unit for calculating the current through one or a plurality of conductors on the basis of the read output signals and on the basis of coefficients which describe the influence of currents flowing through each of the n conductors and of a constant magnetic

25

30

field on the output signal of each of the magnetic-field-sensitive sensors.

The present invention thus permits a reduction of the re-
5 quired magnetic-field-sensitive sensors from $2n$ to $n+1$, when
the current flowing through n conductors is to be detected.
In addition, the present invention permits a compensation of
influences, which are caused by closely spaced, current-
carrying conductors, on the current measurement in one con-
10 ductor. It follows that the present invention provides, on
the one hand, a relatively simple current measuring device,
which provides, on the other hand, exact results in the case
of electric conductors arranged in close proximity to one an-
other.

15

The magnetic-field-sensitive sensors are preferably Hall sen-
sors which are monolithically produced on a semiconductor
substrate together with the evaluation electronics, i.e. the
read-out unit and the calculating unit, and, preferably, to-
20 gether with a memory for storing the coefficients.

In accordance with a further aspect of the invention this ob-
ject is achieved by a method of measuring the current through
one or a plurality of conductors of an array of n conductors,
25 n being a natural number ≥ 2 , wherein the output signals of
 $n+1$ magnetic-field-sensitive sensors are first read out, two
respective ones of these sensors being arranged adjacent a
respective conductor. Subsequently, the current through one
or a plurality of the conductors is calculated on the basis
30 of the read output signals and on the basis of coefficients
which describe the influence of currents flowing through each
of the n conductors and of a constant magnetic field on the

output signal of each of the magnetic-field-sensitive sensors.

Preferred embodiments of the method according to the present invention additionally comprise the step of executing a calibration measurement so as to calculate the coefficients. In so doing, the coefficients are determined as matrix coefficients in such a way that a defined current is conducted through each of the conductors in turn while the other conductors do not carry a current. In addition, a further calibration measurement is carried out in the case of which a constant magnetic field, i.e. a gradient-free magnetic field having a known magnitude, is applied to the magnetic-field-sensitive sensors, while no current flows through the conductors. For calculating the current flowing through one or a plurality of the conductors, the sensor signals of all the magnetic-field-sensitive sensors are then linearly interconnected via a matrix operation making use of the coefficient matrix determined.

20

As has been mentioned hereinbefore, the magnetic-field-sensitive sensors are preferably Hall sensors. These Hall sensors are sensitive to perpendicularly impinging magnetic fields so that the sensors are arranged between the conductors or, displaced upwards or downwards, in the space between the conductors.

25

In addition, the present invention also permits the use of sensors which are sensitive to magnetic fields impinging parallel to the surface, e.g. field plates. These sensors are arranged in such a relation to the conductors that the magnetic field generated by the conductors impinges on the sensors substantially parallel to the surface thereof.

30

BRIEF DESCRIPTION OF THE DRAWINGS

5 In the following, preferred embodiments of the present invention will be described in detail making reference to the drawings enclosed, in which:

10 Fig. 1 shows schematically a known current measuring device;

Fig. 2 shows schematically a current measuring device according to the present invention;

15 Fig. 3 shows schematically an alternative arrangement of Hall sensors for executing a current measurement according to the present invention;

20 Fig. 4 shows an arrangement of field plates for executing a current measurement according to the present invention; and

25 Fig. 5 shows a schematic representation of the current measuring device according to the present invention.

DESCRIPTION OF PREFERRED EMBODIMENTS OF THE INVENTION

30 Fig. 2 shows schematically the array of magnetic-field-sensitive sensors according to the present invention used for measuring the current in three conductors L1, L2, L3 which are arranged in close proximity to one another. As can be

6

seen in Fig. 2, only four magnetic-field-sensitive sensors S1, S2, S3 and S4 are required for measuring the currents in the conductors L1, L2, L3. The four sensors are arranged in such a way that two respective ones of the magnetic-field-sensitive sensors, e.g. S1 and S2, are arranged adjacent a respective conductor, e.g. L1. For detecting the current through one of the conductors, the output signals of all magnetic-field-sensitive sensors S1 to S4 are now linearly interconnected via a matrix operation, the matrix coefficients being determined via a calibration measurement in such a way that a defined current is conducted through each of the conductors in turn while the other conductors do not carry a current.

In addition, a calibration measurement is carried out in the case of which the array has applied thereto a known constant magnetic field while no current flows through the conductors.

The resultant matrix of coefficients reads:

$$\begin{bmatrix} a_{11} & a_{12} & a_{13} & a_{14} \\ a_{21} & a_{22} & a_{23} & a_{24} \\ a_{31} & a_{32} & a_{33} & a_{34} \\ a_{g1} & a_{g2} & a_{g3} & a_{g4} \end{bmatrix}$$

The coefficients a_{11} to a_{14} are obtained while only the conductor L1 carries a known current, the coefficients a_{21} to a_{24} are obtained while only the conductor L2 carries a known current, and the coefficients a_{31} to a_{34} are obtained while only the conductor L3 carries a known current. The coefficients a_{g1} to a_{g4} are obtained while a known constant magnetic field is applied and while none of the conductors carries a current.

The first number of the index of a respective coefficient stands for a conductor, whereas the respective second number in the index stands for a sensor so that e.g. the coefficient a_{11} describes the influence of a current through the conductor L1 on the output signal of the sensor S1. In the case of the coefficients a_{g1} to a_{g4} the letter g stands for the respective constant magnetic field so that these coefficients describe the influence of a constant magnetic field on the output signal of the respective sensor.

Making use of the above coefficients, the output signals A_1 to A_4 of the four magnetic-field-sensitive sensors S1 to S4 are composed as follows:

$$A_1 = a_{11} \cdot I_1 + a_{21} \cdot I_2 + a_{31} \cdot I_3 + a_{g1} \cdot H_g$$

$$A_2 = a_{12} \cdot I_1 + a_{22} \cdot I_2 + a_{32} \cdot I_3 + a_{g2} \cdot H_g$$

$$A_3 = a_{13} \cdot I_1 + a_{23} \cdot I_2 + a_{33} \cdot I_3 + a_{g3} \cdot H_g$$

$$A_4 = a_{14} \cdot I_1 + a_{24} \cdot I_2 + a_{34} \cdot I_3 + a_{g4} \cdot H_g$$

wherein I_1 stands for a current through the conductor L1, I_2 stands for a current through the conductor L2, I_3 stands for a current through the conductor L3 and H_g stands for an applied constant magnetic field.

The above equations can be represented as follows in the form of a matrix or in the form of vectors:

$$\begin{bmatrix} A_1 \\ A_2 \\ A_3 \\ A_4 \end{bmatrix} = \begin{bmatrix} a_{11} & a_{12} & a_{13} & a_{14} \\ a_{21} & a_{22} & a_{23} & a_{24} \\ a_{31} & a_{32} & a_{33} & a_{34} \\ a_{g1} & a_{g2} & a_{g3} & a_{g4} \end{bmatrix} \cdot \begin{bmatrix} I_1 \\ I_2 \\ I_3 \\ H_g \end{bmatrix}$$

After an inversion of the matrix of coefficients, the individual currents I_1 to I_3 flowing through the conductors L1 to L3 can therefore be calculated as follows:

5

$$\begin{bmatrix} I_1 \\ I_2 \\ I_3 \\ H_g \end{bmatrix} = \begin{bmatrix} a_{11} & a_{12} & a_{13} & a_{14} \\ a_{21} & a_{22} & a_{23} & a_{24} \\ a_{31} & a_{32} & a_{33} & a_{34} \\ a_{g1} & a_{g2} & a_{g3} & a_{g4} \end{bmatrix}^{-1} \cdot \begin{bmatrix} A_1 \\ A_2 \\ A_3 \\ A_4 \end{bmatrix}$$

In this way, the current through each of the electric conductors L1 to L3 can be calculated precisely according to the present invention, only $n-1$ magnetic-field-sensitive sensors being necessary for this purpose, when the current through n conductors is to be measured. The above-mentioned calculating method additionally permits the detection of the constant magnetic field.

15

Fig. 3 shows a schematic representation for illustrating an alternative array of magnetic-field-sensitive sensors with respect to three conductors in which a current is to be measured. Also in this case, four sensors S1 to S4 are arranged with respect to three conductors L1 to L3 in such a way that two respective magnetic-field-sensitive sensors are arranged adjacent a respective conductor. In this case, the sensors are, however, arranged such that they are displaced perpendicularly with respect to an imaginary line extending through the conductors, the sensors being e.g. displaced upwards or downwards with respect to the conductors. Such an arrangement can e.g. be realized easily when the sensors are Hall sensors and when they are monolithically produced on a semiconductor substrate together with the conductors. The conductor tracks L1 to L3, which are shown in Fig. 3 only schematically with

30

a round cross-section, may here be e.g. conductor tracks on top of which a dielectric layer is arranged, the magnetic-field-sensitive sensors being then arranged on this dielectric layer. The arrangement shown in Fig. 3, or an arrangement of the sensors directly between the conductors is used, when the sensors are sensitive to perpendicularly impinging magnetic fields.

Fig. 4 shows an arrangement of sensors in relation to conductors in cases in which the sensors are sensitive to magnetic fields impinging parallel to the surface, as in the case of field plates by way of example. In this arrangement the field lines of a magnetic field, which is generated by currents through the conductors L1 to L3, extend parallel to the main surfaces of the sensors S1 to S4. Also in this case, only $n+1$ magnetic-field-sensitive sensors will be necessary for measuring the currents through n conductors.

A schematic general representation of a current measuring device according to the present invention is shown in Fig. 5. The arrangement of the three conductors L1 to L3 and of the four magnetic-field-sensitive sensors S1 to S4 can be seen once more in this representation. The magnetic-field-sensitive sensors S1 to S4 are each connected to an evaluation unit 10. More specifically, the sensors S1 to S4 are connected to a read-out unit 12 of the evaluation unit. In the evaluation unit 10 the above-described calculation of the current flowing through the respective conductors L1 to L3 is carried out. In addition, the evaluation unit 10 is preferably provided with a calibration unit 14 by means of which the above-described coefficients are determined. For this purpose, the calibration unit 14 is connected in a suitable manner to the respective conductors L1 to L3 so as to be able to

cause a known flow of current through these conductors. This is shown in Fig. 5 by the schematically shown conductors between the calibration unit 14 and the respective conductors L1 to L3. Furthermore, a means for generating a known constant magnetic field (not shown) is preferably provided so as to permit the coefficients a_{g1} to a_{g4} to be determined. Alternatively, each of these coefficients may be given the value 1 or some other predetermined value. In addition, the evaluation unit 10 preferably comprises a memory 16 in which the coefficients determined are stored preferably in the form of a matrix. The coefficients can either be stored in the form determined; preferably, however, the elements of the inverted matrix are first calculated from the coefficients determined, these elements being then stored in the memory 16. It is apparent that the memory 16 may be integrated in the evaluation unit 10, although it is shown separately from this evaluation unit in Fig. 5.

It follows that the present invention provides a current measuring device and a method for measuring a current, respectively, in the case of which only $n+1$ magnetic-field-sensitive sensors are required for measuring the current through n conductors. Although the figures only show conductors L1 to L3 which are arranged in juxtaposition, the present invention can also be applied to conductor arrays in which the conductors extend at right angles to one another, e.g. in a multilayered substrate; also in this case, only $n+1$ magnetic-field-sensitive sensors are required.

Claims

1. A current measuring device for measuring a current through one or a plurality of conductors of an array of n conductors, with n being a natural number and $n > 2$,
5 comprising the following features:

$n+1$ magnetic-field-sensitive sensors which are arranged in such a way that two respective magnetic-field-sensitive sensors are arranged adjacent a respective
10 conductor;

a unit for reading out output signals of the magnetic-field-sensitive sensors; and

15 a unit for calculating the current through one or a plurality of conductors on the basis of the read output signals and on the basis of coefficients which describe an influence of currents flowing through each of the n conductors and of a constant magnetic field on the out
20 put signal of each of the magnetic-field-sensitive sensors.

2. A current measuring device according to claim 1, wherein the magnetic-field-sensitive sensors are arranged such
25 that each conductor is arranged between two of said magnetic-field-sensitive sensors.

3. A current measuring device according to claim 1, wherein the magnetic-field-sensitive sensors are arranged such
30 that they are displaced perpendicularly with respect to an imaginary line extending between two conductors.

4. A current measuring device according to claim 1, wherein the magnetic-field-sensitive sensors are Hall sensors.

5. A current measuring device according to claim 4, wherein the Hall sensors, together with the read-out unit and the calculating unit, are monolithically integrated on a semiconductor substrate.

5

6. A current measuring device according to claim 1, wherein the coefficients in a form of a matrix are stored in a memory means.

10

7. A current measuring device according to claim 5, wherein the coefficients in the form of a matrix are stored in a memory means and wherein the memory means is integrated on the semiconductor substrate.

15

8. A method of measuring a current through one or a plurality of conductors of an array of n conductors, with n being a natural number and $n > 2$, comprising the following steps:

20

reading out the output signals of $n+1$ magnetic-field-sensitive sensors, two respective ones of said sensors being arranged adjacent a respective conductor;

25

calculating the current through one or a plurality of the conductors on the basis of the read output signals and on the basis of coefficients which describe an influence of currents flowing through each of the n conductors and of a constant magnetic field on the output signal of each of the magnetic-field-sensitive sensors.

30

9. A method according to claim 8, comprising in addition the step of determining the coefficients on the basis of the output signal of each of the magnetic-field-sensitive

sensors while a known flow of current is successively caused through each of the conductors, whereas no current flows through a rest of the conductors, and on the basis of the output signal of each of the magnetic-field-sensitive sensors during application of a known constant magnetic field, while no current flows through the conductors.

5
10. A method according to claim 9, comprising in addition the step of storing the coefficients.

10

11. A method according to claim 8, wherein the calculation step comprises an execution of a linear interconnection of the output signals of the magnetic-field-sensitive sensors by means of a matrix operation, the coefficients which describe the influence of currents flowing through each of the n conductors and of a constant magnetic field on the output signal of each of the magnetic-field-sensitive sensors (S1 to S4) being used as matrix coefficients.

15

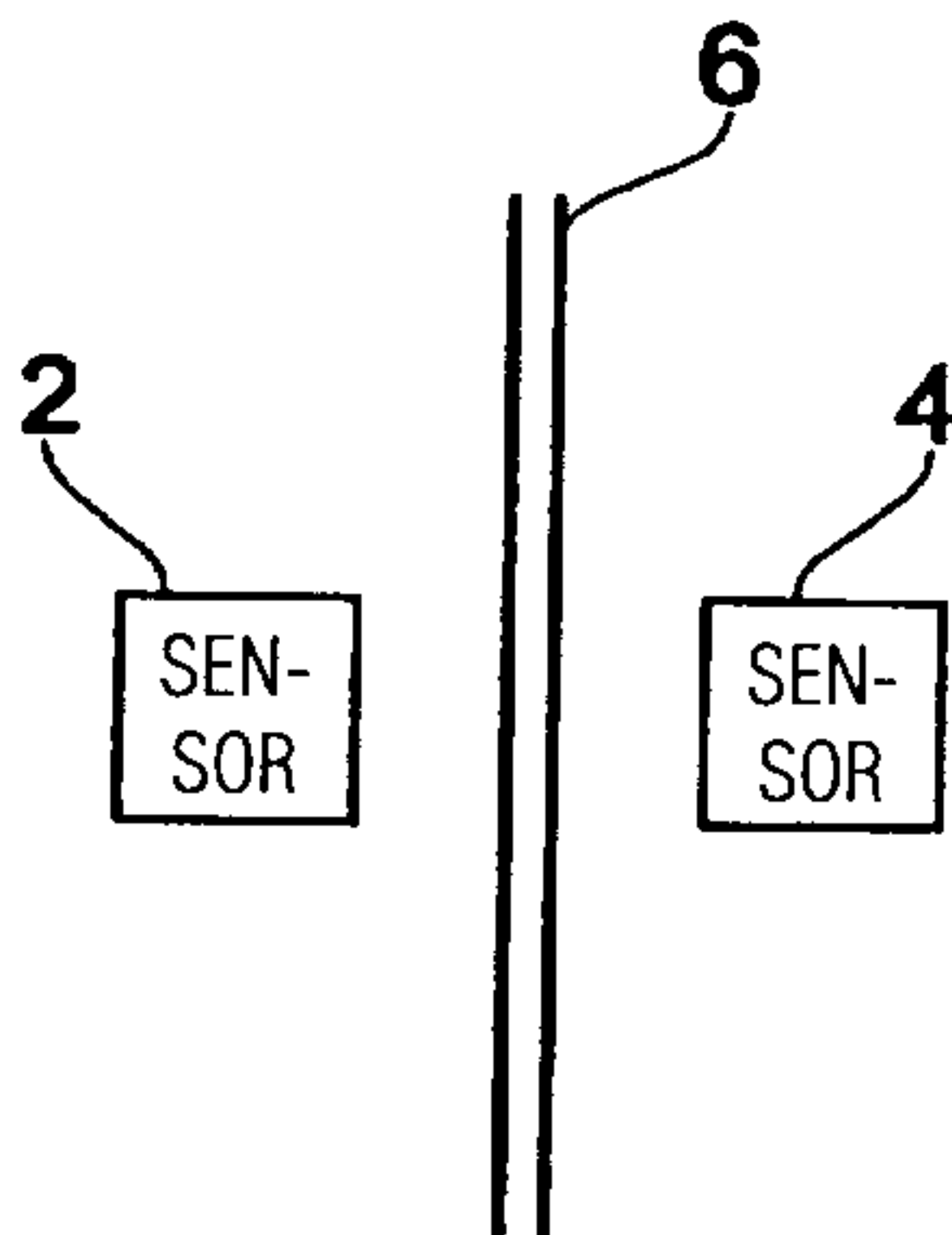

Fig. 1

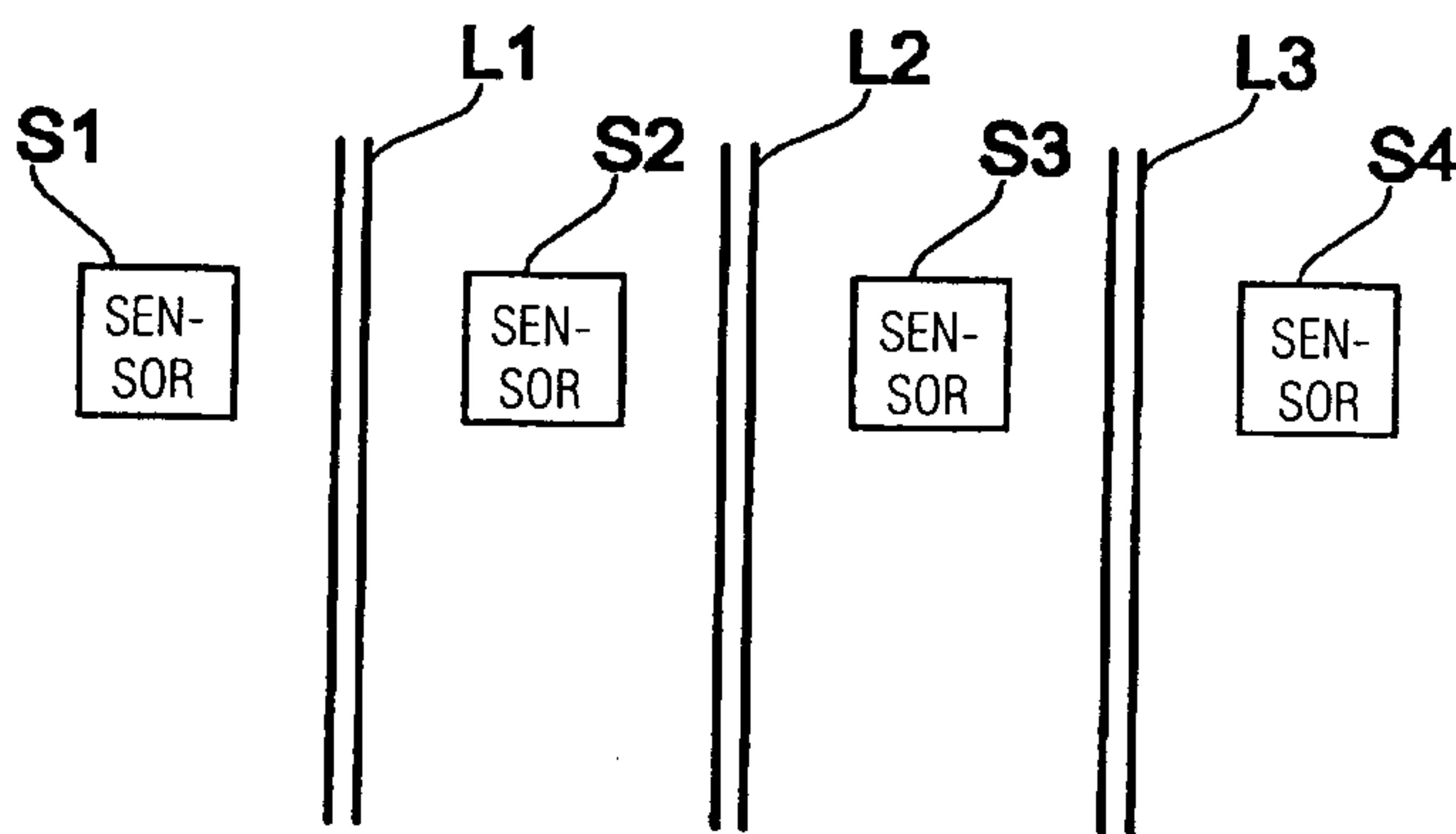

Fig. 2

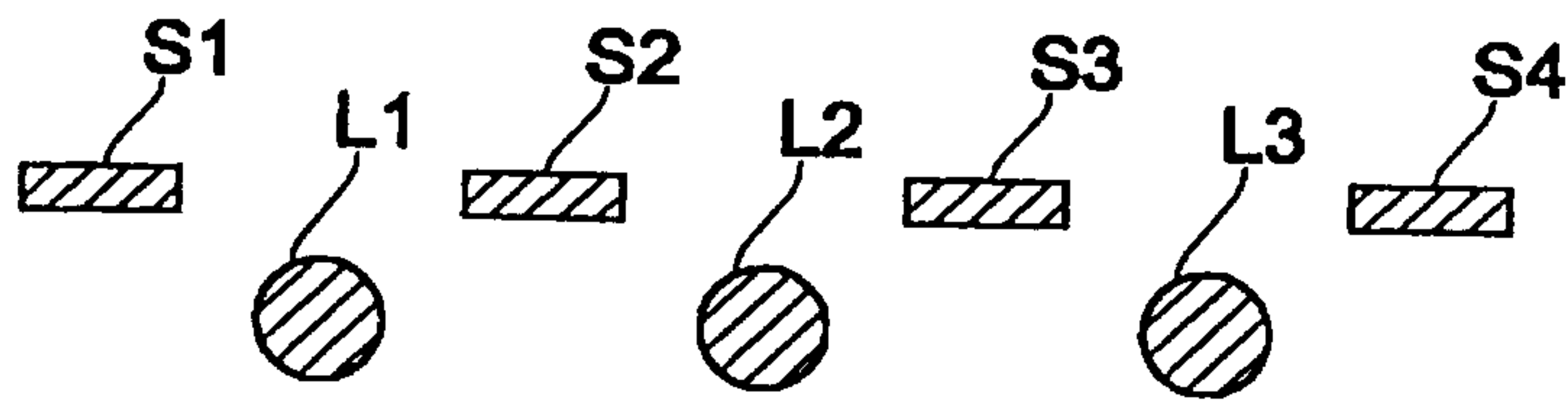

Fig. 3

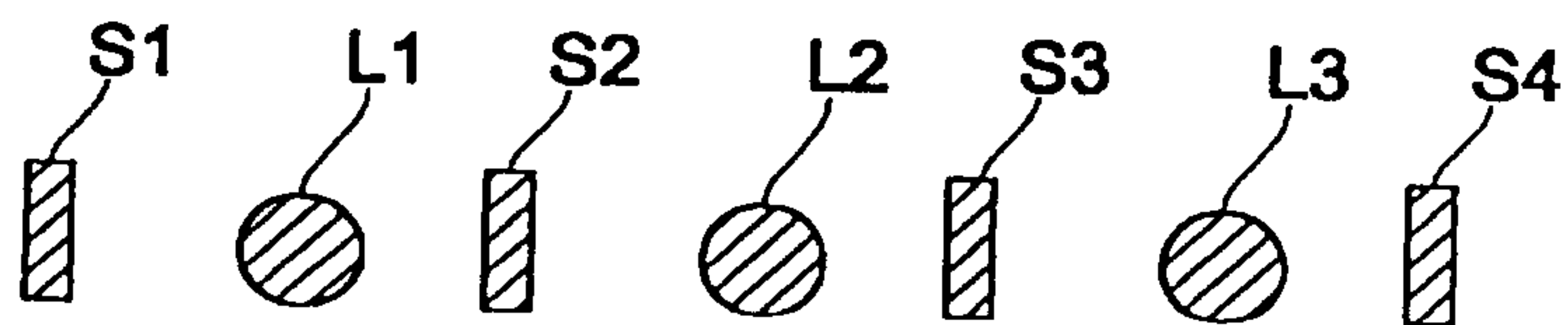

Fig. 4

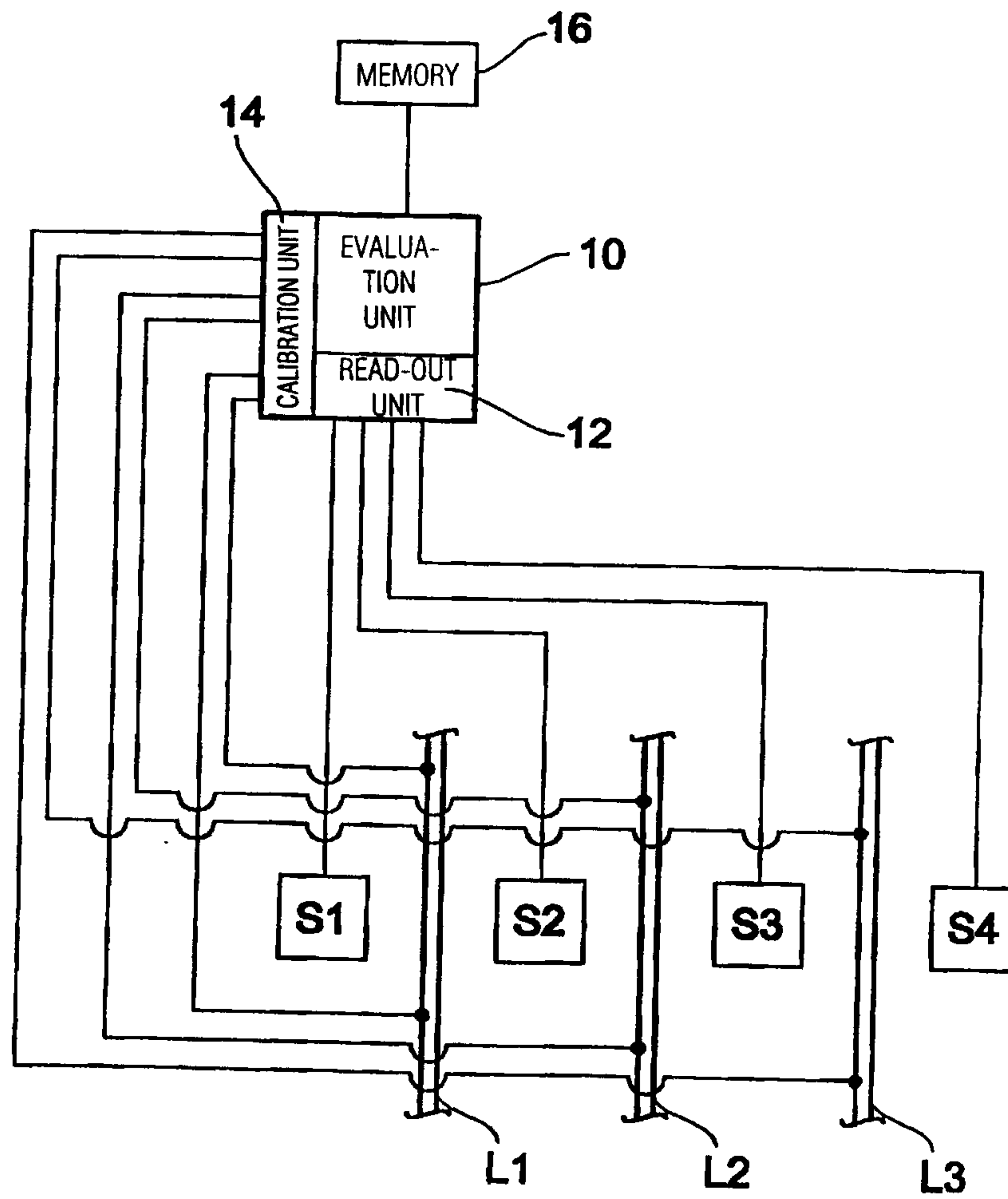

Fig. 5

