

W. CLARK.

Improvement in Machines for Winding Spool-Thread.

No. 128,951.

Patented July 16, 1872.

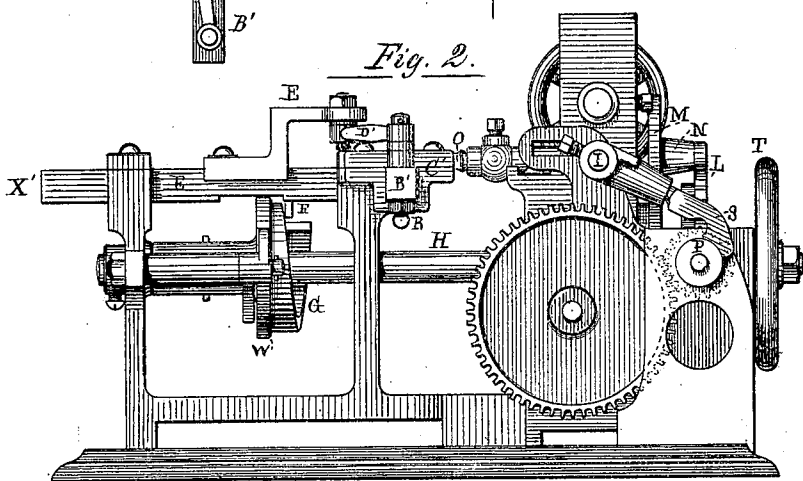
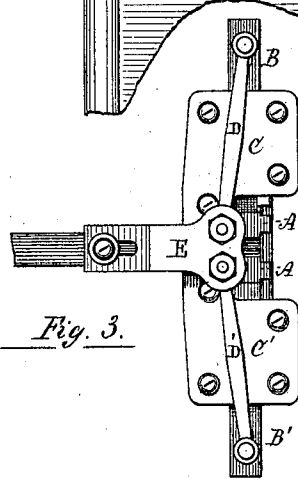
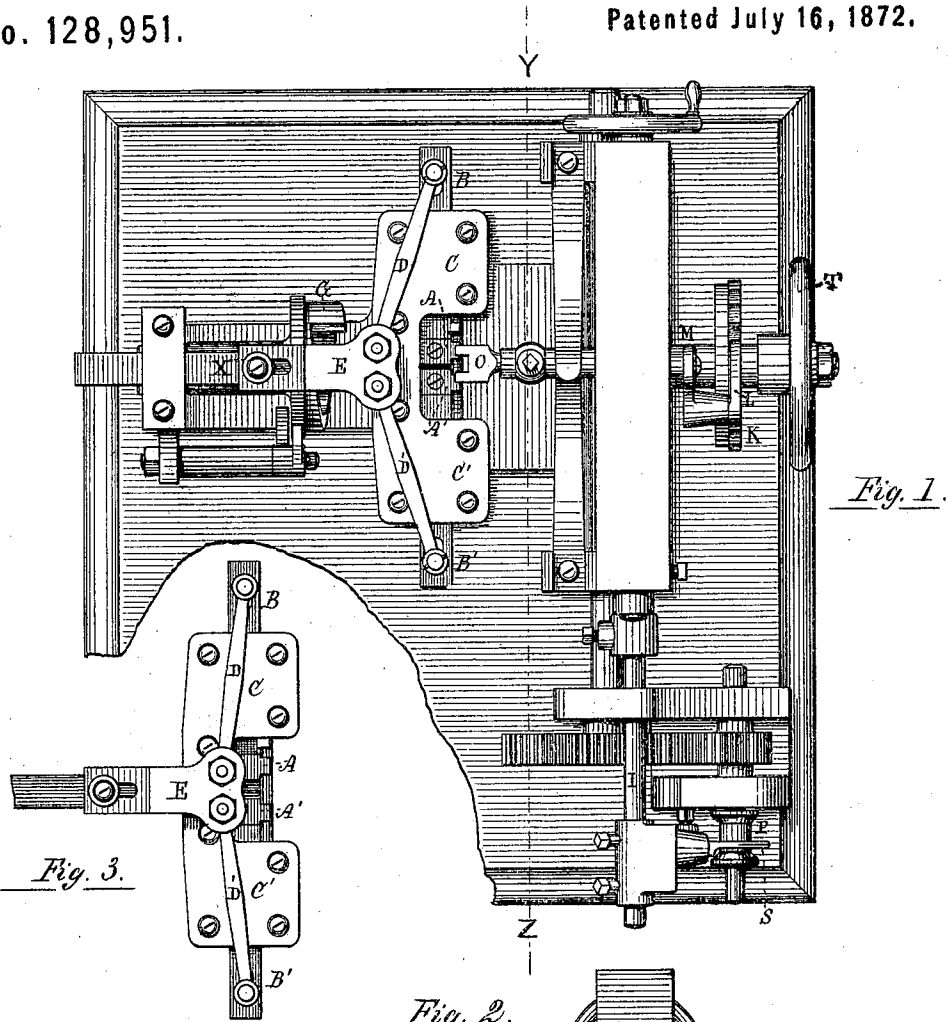

WITNESSES.

E. Eliot
Boyd Eliot

INVENTOR.

William Clark

W. CLARK.

Improvement in Machines for Winding Spool-Thread.

No. 128,951.

Patented July 16, 1872.

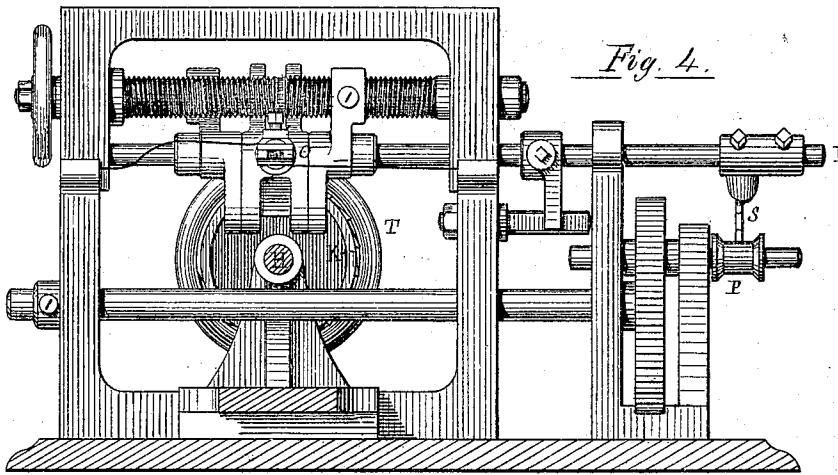

Fig. 4.

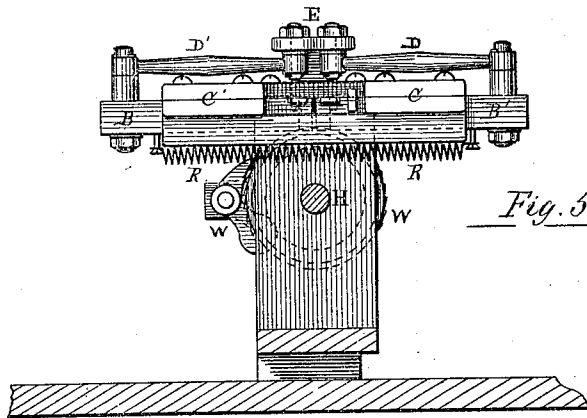

Fig. 5.

WITNESSES.

E. Eliot
Boyd Eliot

INVENTOR.

William Clark

UNITED STATES PATENT OFFICE.

WILLIAM CLARK, OF NEWARK, NEW JERSEY.

IMPROVEMENT IN MACHINES FOR WINDING SPOOL-THREAD.

Specification forming part of Letters Patent No. 128,951, dated July 16, 1872.

WILLIAM CLARK'S specification, describing certain Improvements in Machines for Winding Spool-Thread, invented by WILLIAM CLARK, of Newark, in the county of Essex and State of New Jersey.

This invention belongs to that class of machines used for the winding of thread upon spools, in which it is required that the several layers shall be graduated to meet the shape of the ends of the spools, and the object of the invention is to make the thread guide easily and quickly adapted to the various kinds of work to be done, so that threads of various sizes may be wound on the same machine and upon various-shaped spools without the interchanging of the parts of the machine or the trouble and cost of making and using a great variety of cams or graduating devices. The invention then consists in the combination, with the thread-guide of the winding-machine, of a pair of adjustable guides operated automatically by intermediate mechanism connecting said guides with the traverse-bar or guide-rod, and in such a manner that each layer of thread shall be laid upon the spool the required distance to fill the space between the heads or ends thereof, as desired.

Drawing.

Figure 1, Sheet 1, represents a plan or top view of the mechanism in this invention. Fig. 2 is an end view of the same in elevation taken from that end of the machine where the spool is placed. Fig. 3 is a plan, showing the guides expanded nearly to their greatest extent and in contrast to their position shown in Fig. 1, where they are nearly closed. Fig. 4, Sheet 2, is a view in elevation and partly in section taken from the inner side of the traversing mechanism or between the guides and the traverse-bar. Fig. 5 is a view in elevation and in the same plane of section as Fig. 4 and in opposition thereto, showing the ends of the guides. Both Figs. 4 and 5 represent a cross-section and elevation taken in the plane Y Z of Fig. 1.

The entire machine for winding thread upon spools is not here shown, but only so much as is deemed necessary to explain the improvements now presented for a patent; and it may here be explained that a variety of devices have been patented for regulating the

movement of the thread-guide or traverse-bar, which carries it, as may be seen in the English patent of Wm. Young, in which a "shaper," conformed substantially to a section of one side of the spool, is introduced to determine when and how far the traverse-bar and its thread-guide shall move. Also, the "stops" in an English patent to one Webberly, and also the "cam" or wheel of graduated teeth in the United States patent to one Conant. Reference may also be made to the English and United States patents to Weild, whose machines are very complete, and in which a tapering tongue is used to regulate the action of the traverse-bar and which answers the purpose admirably, but lacks the capacity of adjustment and therefore requires a variety of said tongues to be kept ready to adapt the machine to all kinds of shapes of spools and varieties of thread.

To meet this want the present invention is made, and the improvement is shown at A A', where two pieces of metal are firmly fastened upon two sliding-bars, B B', arranged to work in suitable bearings, C C', mounted on the frame of the machine. Said slides B B' are connected at their outer extremities by two rods or arms, D D', to a second slide, E, which moves in suitable bearings at a right angle to the first pair of slides B B' and forms thereby a combination of mechanism similar to the "toggle" or "elbow-joint." Underneath the sliding-bar E a pin or stud, F, Fig. 2, projects down sufficiently to work against the face of a scroll or cam-wheel, G, which is mounted upon a shaft, H, which extends under the right-and-left screws that operate the traverse-bar I. Upon or near the front end of said shaft H a ratchet-wheel, K, is fastened, and receives its motion from a pawl, L, which is attached to a vibrating-lever, M, one end of which is mounted upon the shaft H or concentric therewith, and is caused to vibrate by an adjustable pin, N, working in a slot in the face of a vertical block fastened upon the traverse-bar. The pin N is made adjustable in the lever M to vary the vibration of the pawl L and thereby vary the movement of the scroll or cam-wheel G. It is evident that by such a combination of parts the guides A A', when closed or nearly so, as shown in Fig. 1, will be opened or spread apart by the rotation of the

shaft H, as it is caused to move by the pawl L working from the to-and-fro motion of the traverse-bar, and therefore, as each successive layer of thread is laid upon the spool, the guides A and A' will by their spreading apart furnish a greater space for the tripping-finger O (that throws the sectional nuts alternately in contact with the right-and-left screws) to traverse, and therefore the time of winding each layer of thread will be continued just so much longer.

To what extent such an increase of motion shall be, is determined by placing the spool P upon its mandrel and dropping the thread-guide S to the starting-point for winding the thread, then turn the shaft H, by means of the hand-wheel T, until the pin F shall rest against the lowest point on the scroll-wheel or cam G, or to such a point thereon as shall hold the guides A and A' the proper distance apart for the requisite traverse of the finger O, to hold the sectional nut in contact with its screw for the first layer of thread, then adjust the pin N in the slotted lever M, to give the requisite throw to the pawl L upon the ratchet K, so that the proper expansion of the guides shall be produced at each traverse of the finger O, to carry the thread in each successive layer from end to end of the spool; then will the operation continue until the pin F drops from the face of the cam-wheel G, at which time the spool, if of the proper size, will be filled; and the winding mechanism should then stop until an empty spool is supplied to the machine. As soon as the pin F passes the highest point on the cam G, the slide E is forced back to its first position by the contraction of the spring R, which is attached to the slides B B', and which closes the guides A A' when the cam G ceases to act upon the pin F.

Since the guides A A' are acted upon by the toggle-arms D D' it is evident that the expansion of said guides will be greater at the first movement of the slide E than the second, or each succeeding one, or as the arms D D' approach more nearly a straight line; and therefore if the inner ends of the spool correspond to a straight hypotenuse of a triangle formed by the axis and outer ends of the spool, then the spreading of the guides must be regular in their expansion, and this may be accomplished by increasing the cam G to give the requisite increase of throw to the guides A A', or the teeth on the ratchet-wheel at K may

be increased to compensate for the decrease of motion from the arms D D'.

To give the proper adjustment between the beginning and ending of the operation of winding, the slides B B' are slotted at their extremities, or where the arms D D' are connected therewith, and the guides A A' may be set at any required distance apart and relatively with the cam G, so that the spools may be varied in their length as compared with their diameter, or the size of the thread, or the number of layers of the thread, and wound successfully without the interchange of parts, as required in many of the machines heretofore referred to; and another very great advantage is gained in the capacity of compensation for the wearing away of the "cams," "stops," "tongues," &c., that have to be so frequently made new in other machines.

To prevent the backward action of the pin F upon the cam G, and while the pawl L is out of contact with a tooth upon the ratchet K, a second ratchet and pawl, as at W, is provided, to hold all the parts in proper working position, and instead of said ratchets and pawls, frictional ratchets on smooth surfaces may be used, so that any throw desired may be obtained and maintained.

As already remarked, the winding operation should cease at the instant the pin F drops from the highest point of the cam G, and this may be easily accomplished by permitting the rear end of the slide E, as at X or X', to strike a lever connected with the shipping mechanism; but as these improvements are now combined with the Weild machines, already referred to, other means are provided to accomplish such an object very accurately.

I therefore claim—

1. The combination of the guides A and A' and expanding mechanism, with the traverse bar of a thread-winding machine, as described, and for the purposes set forth.

2. The combination of the guides A A', slides B B', arms D D', slide E, and cam G, as described, and for the purposes set forth.

3. The combination of a ratchet, as at K, either toothed or smooth, with the guides A A' of a winding-machine, as described, and for the purposes set forth.

WILLIAM CLARK.

Witnesses:

HERMAN MILLER,
E. N. ELIOT.