



(43) International Publication Date
11 December 2014 (11.12.2014)

- (51) International Patent Classification:
E02F 3/36 (2006.01)
- (21) International Application Number:
PCT/NO2014/050093
- (22) International Filing Date:
5 June 2014 (05.06.2014)
- (25) Filing Language:
Norwegian
- (26) Publication Language:
English
- (30) Priority Data:
20130795 6 June 2013 (06.06.2013) NO
- (71) Applicant: **HARDNOR AS** [NO/NO]; P.O. Box 1293, N-5406 Stord (NO).
- (72) Inventor: **ELDØY, Bjørn**; Eldøyvegen 59, N-5411 Stord (NO).
- (74) Agent: **ACAPO AS**; P.O. Box 1880 Nordnes, N-5817 Bergen (NO).
- (81) Designated States (*unless otherwise indicated, for every kind of national protection available*): AE, AG, AL, AM,

AO, AT, AU, AZ, BA, BB, BG, BH, BN, BR, BW, BY, BZ, CA, CH, CL, CN, CO, CR, CU, CZ, DE, DK, DM, DO, DZ, EC, EE, EG, ES, FI, GB, GD, GE, GH, GM, GT, HN, HR, HU, ID, IL, IN, IR, IS, JP, KE, KG, KN, KP, KR, KZ, LA, LC, LK, LR, LS, LT, LU, LY, MA, MD, ME, MG, MK, MN, MW, MX, MY, MZ, NA, NG, NI, NO, NZ, OM, PA, PE, PG, PH, PL, PT, QA, RO, RS, RU, RW, SA, SC, SD, SE, SG, SK, SL, SM, ST, SV, SY, TH, TJ, TM, TN, TR, TT, TZ, UA, UG, US, UZ, VC, VN, ZA, ZM, ZW.

- (84) Designated States (*unless otherwise indicated, for every kind of regional protection available*): ARIPO (BW, GH, GM, KE, LR, LS, MW, MZ, NA, RW, SD, SL, SZ, TZ, UG, ZM, ZW), Eurasian (AM, AZ, BY, KG, KZ, RU, TJ, TM), European (AL, AT, BE, BG, CH, CY, CZ, DE, DK, EE, ES, FI, FR, GB, GR, HR, HU, IE, IS, IT, LT, LU, LV, MC, MK, MT, NL, NO, PL, PT, RO, RS, SE, SI, SK, SM, TR), OAPI (BF, BJ, CF, CG, CL, CM, GA, GN, GQ, GW, KM, ML, MR, NE, SN, TD, TG).

Published:

— with international search report (Art. 21(3))

(54) Title: QUICK COUPLING FOR CONNECTION OF A TOOL TO A MACHINE

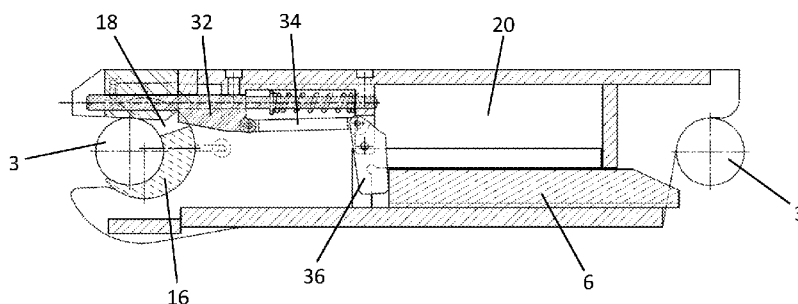

Fig. 10

(57) Abstract: Quick coupling (1) for fastening of a tool (4) to a machine (8) is described, comprising a frame (14) equipped with ordinary fastening appliances (2) for fastening to the machine (8) and a pressure cylinder (7) arranged to drive a first and a second locking device (5, 6) in opposite directions and engage with respective first and second fastening shafts (3) on the tool (4), where at least one of said locking devices (5) comprises a cradle (16) with an internal approximate U-shape that is arranged to contain the fastening shaft (3), and which is mounted to rotate eccentrically with respect to the centre axis of the fastening shaft (3) under the influence of the pressure cylinder (7). The quick coupling (1) is equipped with a locking- and securing device (30) to prevent that the cradle (16) rotates out of its engagement with the fastening shaft (3), where the locking- and securing device (30) comprises a pin (32) that is arranged to be inserted into a recess (18) on the cradle (16).



Quick coupling for connection of a tool to a machine

5

The invention relates to a quick coupling for fastening of a working tool to a machine, comprising a frame equipped with ordinary fastening devices for fastening to the machine and a pressure cylinder arranged to drive a first
10 and a second locking device in opposite directions and engage with respective first and second fastening shafts on the tool, where at least one of said locking devices comprises a cradle with an internal, approximate U-shape that is arranged to contain the fastening shaft and which
15 is mounted to rotate eccentrically with respect to the centre axis of the fastening shaft under the influence of the pressure cylinder.

The present solution describes a method to secure a quick
20 coupling to a working tool. The mounting of end pegs on a cradle shaft and the placing of the centre of a fastening shaft leads to an eccentric rotation. The rotation between bearing and the centre has a short moment arm with respect to the moment arm of a jack and the centre.

25

The mounting has an extremely favourable position for the power transfer to the fastening shaft when the pre-tension that the jack exerts after it has been activated for locking. This leads to the fastening lying steady and a
30 large reverse force being required to counteract the pre-tension from the jack.

The movement which this solution builds on is important to avoid wear. The movement of the jack stretches the fastening shafts in the longitudinal direction at the same time as it forces the coupling towards the fastening shaft
5 in both ends.

The content of the present application is a further development of NO333221B1 belonging to the same owner.

10 From other patent literature reference is made to, among others, EP 0143074 A1 and US 5692325 A and both show a quick coupling for the fastening of a tool to a machine, comprising a frame fitted on one side with ordinary fastening appliances for fastening to the machine and on
15 the opposite side with a pressure cylinder arranged to drive a first and a second locking device in opposite directions and engage with respective first and second fastening shafts on the tool and where at least one of said locking devices is formed with a cradle-like shape
20 that is arranged to contain the fastening shaft.

US 5382110 A shows a quick coupling for the fastening of a tool to a machine, comprising a frame fitted on one side with ordinary fastening appliances for fastening to the
25 machine and on the opposite side with a motor-driven gear transmission arranged to drive a locking device to engage with a fastening shaft on the tool and where said locking device is formed in a cradle-like shape that is arranged to contain the fastening shaft, and where said locking
30 device is mounted to rotate eccentrically with respect to the centre axis of the fastening shaft under the influence of the gear transmission.

Furthermore, FR 2760029 A1 shows a quick coupling for fastening of a tool to a machine, comprising a frame fitted on one side with ordinary fastening appliances for fastening to the machine and on the opposite side with an actuator and a spring with respective cradles that form a common cradle arranged to contain a fastening shaft and arranged to rotate eccentrically with respect to the centre axis of the fastening shaft.

Reference is also made to WO 2012/156672 A1, AU 2008202616 A1, EP 1318242 A2 and US 2009129858 A1 which all show examples of quick couplings for fastening of a tool to a machine.

For sale in Scandinavia today are fastening solutions with a wedge at the rear edge for locking and a more recent solution with a "standard" wedge at both ends. This type of fastening forces either one wedge or two wedges (one in each end of the cylinder) directly against the under edge of the fastening bolts on the tool. When this is taken into use the result will be that forces from the tool (the digging bucket) go through the fastening bolts and push against the wedges that are held in place by a hydraulic cylinder. This will "yield" and a completely rigid connection will not be achieved. These small movements result in wear and slack over many hours of use.

Quick couplings that use two wedges are, as mentioned, well known. A problem with the known solutions is that the tolerance during the fastening of the tool is not taken up, which leads to greater wear on the equipment. The quick coupling described in the application gives a quick coupling that drives a wedge between and straps down

between the fastening shafts on the tool and the side members of the quick coupling.

In particular one aims with the invention to provide a quick coupling with a locking- and securing device that prevents and ensures that at least one of the locking appliances that engages with the fastening shafts goes out of its engagement with the shaft.

Furthermore, one aims to provide a controlled retraction of the locking appliances without the use of dedicated actuators. This is achieved among other things in that the second locking device is arranged during the retraction to inflict an opposite acting force to push the locking device out of the recess on the cradle.

For example, a digger driver can often not see from his place in the machine, during the fitting of the tool (such as a scoop) to the machine whether the scoop is correctly fitted to the quick coupling. In some cases the scoop can "hang" on to only one of the locking devices, and when the beam is lifted the whole scoop can fall off and in the worst case lead to very serious or fatal accidents for personnel that may be in the vicinity. With locking- and securing devices according to the invention one aims to avoid such or similar accidents.

The above mentioned aims are achieved with a quick coupling for the fastening of a tool to a machine, comprising a frame equipped with ordinary fastening appliances for fastening to the machine and a pressure cylinder arranged to drive a first and a second locking device in opposite directions and engage with the

respective first and second fastening shafts on the tool
where at least one of said locking devices comprises a
cradle with an internal, approximate U-shape that is
arranged to contain the fastening shaft and which is
5 mounted to rotate eccentrically with respect to the centre
axis of the fastening shaft under the influence of the
pressure cylinder. The quick coupling is equipped with a
locking and securing device to prevent that the cradle
rotates out of its engagement with the fastening shaft,
10 where the locking- and securing device comprises a pin
that is arranged to be inserted into a recess on the
cradle.

The pin of the locking- and securing device can be
15 arranged so that it can be displaced in the frame and
which, under the influence of a pressure device, such as a
compression spring, is arranged to be pushed into the
recess on the cradle and which, under the influence of an
opposite acting force, is arranged to be pushed out of the
20 recess on the cradle.

The second locking device can, during pulling in, be
arranged to provide said force to push the pin out of the
recess on the cradle.

25

In one embodiment the pin can be suspended so that it can
be displaced on a shaft, said shaft comprising a
compression spring that is arranged to push the pin into
the recess on the cradle of the first locking device, and
30 where the pin is connected with an articulated strut
which, under the influence of the second locking device,
is arranged to permit the displacing of the pin into the
recess when the second locking device is driven out and to

pull the pin out of the recess when the second locking device is driven in.

Further features of the quick coupling are that the shaft
5 can be suspended in a forward and rear fastening arm, that
the compression spring can be arranged about the shaft and
between said fastening arms, that the pin can be formed as
a sliding sleeve that is arranged on the shaft, that the
pin can be equipped with a collar that rests against the
10 compression spring, that the pin can be arranged so that
it can be pushed in a groove in the forward fastening arm,
that the pin can be connected to a first part of the
articulated strut, that a second part of the articulated
strut can be fastened to the rear fastening arm and
15 articulately connected to the first part.

Furthermore, the cradle can, on either side, comprise an
eccentrically mounted end peg arranged in respective side
members, and the cradle can be arranged to contain the
20 fastening shaft, in the main, along the whole axial length
of the fastening shaft.

The second locking device can be a wedge that is driven by
the pressure cylinder to engage with the second fastening
25 shaft, and that the wedge is built with a platform and
extends, in the main, along the whole axial length of the
fastening shaft.

The pressure cylinder can be a hydraulic jack arranged to
30 provide a continuous pressure for both the locking
devices. Furthermore, the pressure cylinder can comprise a
safety valve arranged to trigger at a pressure drop.

The end peg can be formed as a plate that is mounted to the cradle and which lies in a rotary support in a respective side member.

5 The invention shall now be explained in more detail with the help of the enclosed figures that show an embodiment example of the invention, in which:

Figure 1 shows a quick coupling that is mounted between a tool and the arm of a digger.

10 Figure 2 shows a quick coupling.

Figure 3 shows a cradle that is part of the quick coupling.

Figure 4 shows a magnified embodiment of the quick coupling.

15 Figure 5 shows parts of the quick coupling in perspective.

Figure 6 shows a figure corresponding to figure 5, but without the one side member.

20 Figure 7 shows a further variant of a quick coupling according to the invention.

Figure 8 shows a section of a locking- and securing device according to the invention.

The quick coupling described in the application builds on 25 traditional quick couplings 1 for a tool 4 on, for example, diggers 8. As its predecessors, it has as an aim to be able to replace equipment on diggers without any manual labour with fastening or locking, and has as a task to prevent wear between the coupling 1 and the fastening 30 shafts 3.

As mentioned, normal couplings have only a one-sided or two-sided wedge 6 that locks the coupling securely to

tools 4 with the help of a hydraulically driven cylinder 7.

The present quick coupling is also hydraulically driven, but has movable locking mechanisms 5,6 at both ends of the coupling 1. One end of the coupling can, if required, use the old principle of a movable wedge 6, while the opposite end can have a cradle 16 arranged for the fastening shaft 3. The fastening shaft 3 is a fixed, integrated standard part on tools 4 for coupling of this type in various sizes and is permanently welded to side fastening points on the tool.

The quick coupling 1 comprises a frame 14 equipped with associated side members 20. The cradle 16 is arranged to rotate eccentrically with respect to its own mounting 9. This means that the end pegs 10 on the cradle shaft 16 that are mounted in the side members 20 on the quick coupling 1 are eccentrically placed with respect to the geometry 11 of the cradle for the fastening shaft 3. Furthermore, the end pegs 10 can be formed with a corresponding radius to the cradle and can lie in a correspondingly shaped rotary support in the side members 20. The end pegs 10 can be constructed as an integral part of the cradle, or as shown in figure 5 the end pegs can be constructed from a plate 10a that is mounted to the cradle and which lies in the rotary support.

A pressure cylinder in the form of, for example, a hydraulic jack 7 is fastened to the cradle 16 via a fastening strut 16a and the wedge 6, and pushes the wedge and the rotating cradle in opposite directions. The eccentric rotation of the cradle 16 with respect to the

centre of the fastening shaft 3, and also the placing of the fastenings strut 16a provide propulsion and lift in the same movement. This means that both the fastening shafts 3 on the tool 4 are forced into the geometry of an adapted radius, also the end where the traditional wedge functions. This contributes to the tool 4 being completely locked to the coupling 1 and the possibilities for slack and wear are eliminated.

10 With the present principle the forward fastening bolt 3 is wedged up against the side members 20 in the quick coupling in that the cradle 16 is rotated in its "eccentric mounting". The result is then that each end of the cradle 16 which is mounted against the side members 20 forces space until the rear fastening bolt is pressed against the machined seat. Here the wedge also comes out underneath and locks it from being able to move out of the machined seat. Here, when one starts using the tool, the forces that arise will go through the fastening bolts of the tool, via the cradle mounting and into the side members on the fastening. Enormous forces are required to be able to get the cradle to rotate back to result in some slack in the fastening. One can see this on the ratios of the moment arms.

25

The quick coupling 1 is held static with a continuous pressure from a hydraulic cylinder 7. The cylinder 7 is preferably equipped with a safety valve 12 that is triggered by a drop in pressure, this prevents the equipment from falling off at possible breaks in the hose on the digger.

30

The present quick coupling relates to a quick coupling 1 free of wear between the ordinary fastening point 2 on diggers 8 and the fastening shafts 3 on the tool 4. The coupling is, in principle, intended for tools 4 that are designed according to the standard for this type of coupling 1. The aim is to eliminate wear between the tool 4 and the quick coupling 1. The eccentrically rotating cradle 16 for the fastening shafts 3 on tools pre-stresses and stretches up the system together with the wedge 6. This takes place with help of the same power source, the hydraulic jack 7 which has freedom to move both the locking appliances simultaneously and in opposite directions. The principle builds on that there is a greater pre-tension force in the system from the jack 7 than from the load which is returned to the connection under normal use. This will mean that the system has a large efficiency to hold the position with continuous static load from the jack 7. The solution required less with respect to tolerance and can also be used on tools 4 that have been subjected to wear within realistic limits.

Figures 7-10 show in more detail a locking and securing device according to the invention. Figure 7 shows a part of the frame 14 that corresponds to the previously described frame and comprises in the same way a cradle 16 that is mounted eccentrically and which is rotated with the help of the pressure cylinder 7 connected to the fastening strut 16a. Similarly, the wedge 6 is pushed out and in with the help of the pressure cylinder 7.

30

The cradle 16 in the embodiment shown distinguishes itself from the one previously described in that it is equipped with a recess 18. The recess 18 can be a cut out groove

which can run all the way or part of the way through the material of the cradle 16. The recess 18 runs further in the longitudinal direction in the cradle 16. Furthermore, the cradle 16 can be equipped with a plate 22 that rotates
5 with the cradle, where the plate 22 can function as an indicator that sticks out of the quick coupling 1 to indicate that the cradle has rotated into place about the fastening shaft 3 and also as an indicator that the locking- and securing device 30 has engaged with the
10 cradle 16.

The figures 8, 9 and 10 show in more detail the locking- and securing device 30. The locking- and securing device 30 is preferably fastened to or adjoining one or both side
15 members 20. As can be seen, the locking- and securing device can, in one example embodiment, comprise a pin 32 that is arranged to be inserted into the recess 18. The pin 32 can, for that matter, have any shape that fits into the recess 18. Furthermore, the pin 32 can be arranged so
20 that it can glide as a sliding sleeve on a shaft 38, where the shaft 38 is suspended in a forward and rear fastening arm 44,46, for example, fastened to one of the side members 20. A compression spring 40 is arranged about the shaft 38 and pushes against a collar 42 of the pin 32. A
25 lower part of the pin (the sliding sleeve) can extend out through a groove 48 in the forward fastening arm 44 and be fastened to a first part of an articulated strut 34,36. Furthermore, the first part 34 of the strut is connected to a second part 36 of the strut which is rotary mounted
30 to the rear fastening arm 46 so that the strut parts 34,36 form an angle with respect to each other.

The figures 9 and 10 show in more detail how the locking- and securing device 30 functions. In figure 9 the pin 32 of the locking- and securing device 30 has not engaged with the recess 18 on the cradle 16, and the cradle 16 is not prevented from turning to release or to take up the fastening shaft 3. The wedge 6 is driven in and a front edge of the wedge presses against the second part of the strut 36, whereby the second part of the strut 36 rotates (clockwise as shown in the figure), so that the first part of the strut 34 pulls the pin 32 backwards (as shown in the figure). Then, the collar 42 forces the compression spring 40 so that it becomes compressed and pre-stressed. In figure 10 the pressure cylinder 7 drives the wedge 6 out and rotates the cradle 16. The second part of the strut 36 will then be free to rotate the opposite way (anticlockwise in the figure) and the pin 32 will then be pushed forward due to the influence of the first part of the strut 34 and not least the compression spring 40. Alternatively, the compression spring 40 can be arranged in a different way than that shown to generate a corresponding force, for example, in the articulated connection between the two struts 34,36.

The cradle 16 is then securely locked, as shown in figure 10 and prevented from moving. Furthermore, the wedge 6 is driven sufficiently out so that the fastening shaft 3 can glide on the upside of the wedge. If the wedge unexpectedly does not make proper contact so that the rear fastening shaft is not fastened properly, accidents will still be prevented as the forward fastening shaft lies securely in the cradle 16.

C L A I M S

1. Quick coupling (1) for fastening of a working tool
(4) to a machine (8), comprising a frame (14) equipped
5 with ordinary fastening appliances (12) for fastening to
the machine (8) and a pressure cylinder (7) arranged to
drive a first and a second locking device (5, 6) in
opposite directions and engage with respective first and
second fastening shafts (3) on the tool (4), where at
10 least one of said locking devices (5) comprises a cradle
(16) with an internal approximate U-shape that is arranged
to contain the fastening shaft (3), and which is mounted
to rotate eccentrically with respect to the centre axis of
the fastening shaft (3) under the influence of the
15 pressure cylinder (7), characterised in
that the quick coupling (1) is equipped with a locking-
and securing device (30) to prevent that the cradle (16)
rotates out of its engagement with the fastening shaft
(3), where the locking- and securing device (30) comprises
20 a pin (32) that is arranged to be inserted into a recess
(18) on the cradle (16).

2. Quick coupling (1) according to claim 1,
characterised in that the pin (32) of the
25 locking- and securing device (30) is arranged so that it
can be displaced in the frame (14) and which under the
influence of a pressure device (40), such as a compression
spring, is arranged to be displaced into the recess (18)
on the cradle (16) and which under the influence of an
30 opposite acting force is arranged to be displaced out of
the recess (18) on the cradle (16).

3. Quick coupling (1) according to claim 2,
c h a r a c t e r i s e d i n that the second locking
device (6), when being pulled in, is arranged to cause
said force to displace the pin (32) out of the recess (18)
5 on the cradle (16).

4. Quick coupling (1) according to claim 1,
c h a r a c t e r i s e d i n that the pin (32) is
suspended displaceable on a shaft (38), said shaft (38)
10 comprises a compression spring (40) that is arranged to
displace the pin (32) in the recess (18) on the cradle
(16) of the first locking device (5) and that the pin (32)
is connected with an articulated strut (34,36) which under
the influence of the second locking device (6) is arranged
15 to permit the displacement of the pin (32) in the recess
(18) when the second locking device (6) is driven out, and
to pull out the pin (32) from the recess (18) when the
second locking device (6) is driven in.

20 5. Quick coupling (1) according to claim 4,
c h a r a c t e r i s e d i n
that the shaft (38) is suspended in a front and a
rear fastening arm (44,46),
that the compression spring (40) is arranged about
25 the shaft (38) and between said fastening arms (44,46),
that the pin (32) is formed as a sliding sleeve that
is arranged on the shaft (38),
that the pin (32) is equipped with a collar (42) that
rests against the compression spring (40),
30 that the pin (32) is arranged so that it can be
displaced along a groove in the forward fastening arm
(44),

that the pin (32) is connected to a first part of the articulated strut (34),

that a second part of the articulated strut (36) is fastened to the rear fastening arm (46) and is
5 articulately connected to the first part (44).

6. Quick coupling (1) according to claim 1,
c h a r a c t e r i s e d i n that the cradle (16)
comprises on either side an eccentrically mounted end peg
10 (10) arranged in respective side members (20) and that the cradle (16) is arranged to contain the fastening shaft (3), in the main, along the whole axial length of the fastening shaft.

15 7. Quick coupling (1) according to claim 1,
c h a r a c t e r i s e d i n that the second locking device (6) is a wedge that is driven in by the pressure cylinder (7) to engage with the second fastening shaft (3) and that the wedge (6) is constructed in a plate form and
20 which runs, in the main, along the whole axial length of the fastening shaft.

8. Quick coupling (1) according to claim 1,
c h a r a c t e r i s e d i n that the pressure cylinder
25 (7) is a hydraulic jack arranged to give a continuous pressure to both locking devices (5,6).

9. Quick coupling (1) according to claim 1,
c h a r a c t e r i s e d i n that the pressure cylinder
30 (7) comprises a safety valve (12) arranged to be triggered at a drop in pressure.

10. Quick coupling (1) according to claim 6,
c h a r a c t e r i s e d i n that the end peg (10) is
formed as a plate (10a) that is mounted to the cradle (16)
and which lies in rotational support in respective side
5 member (20).

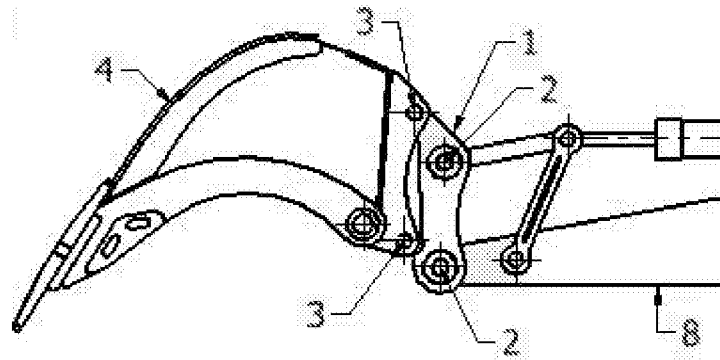

Fig. 1

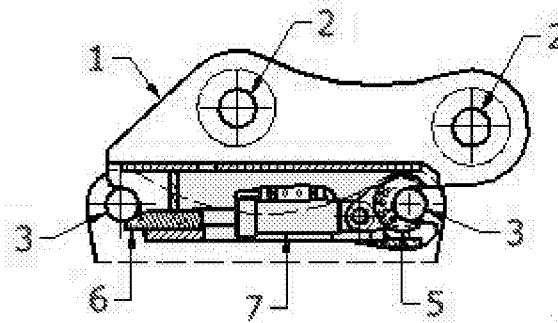

Fig. 2

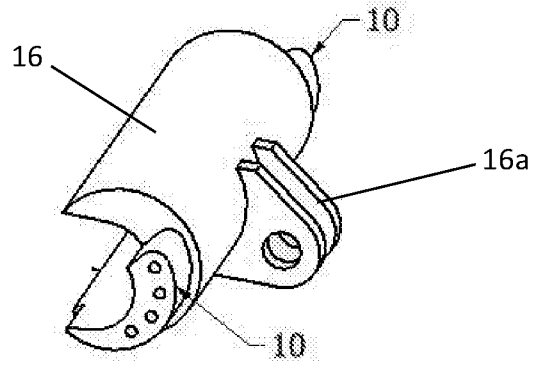

Fig. 3

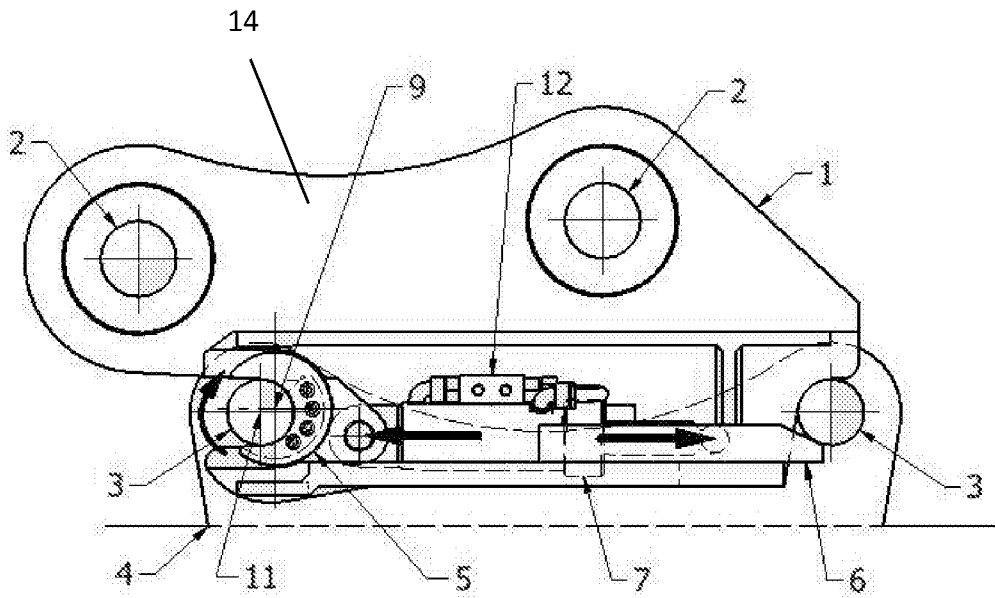

Fig. 4

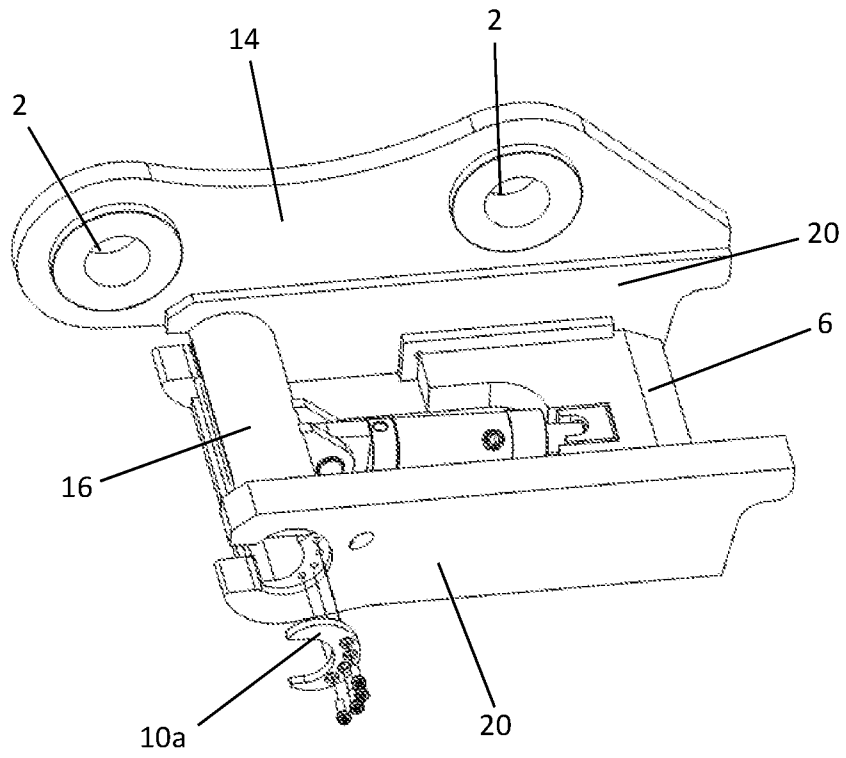

Fig. 5

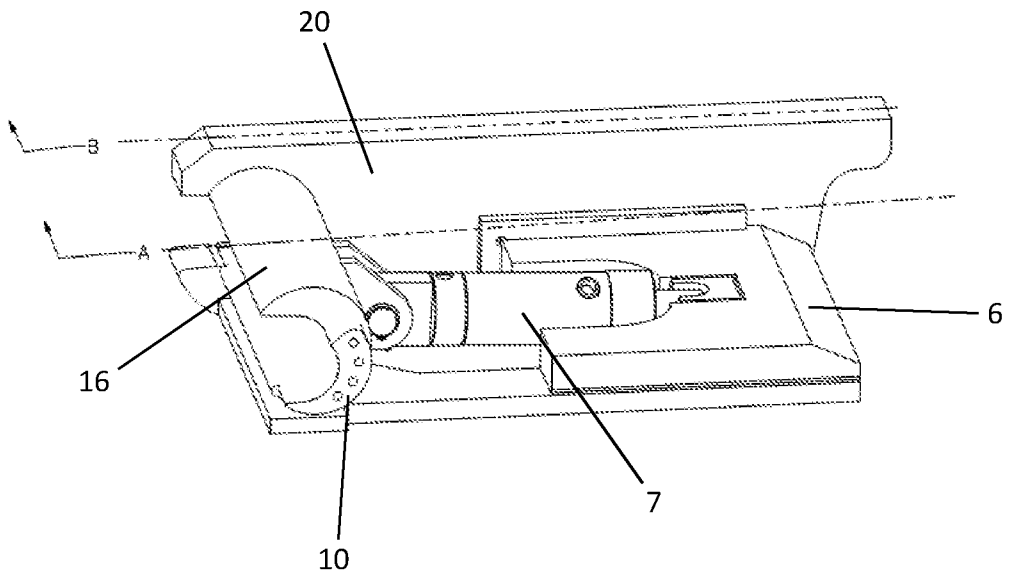
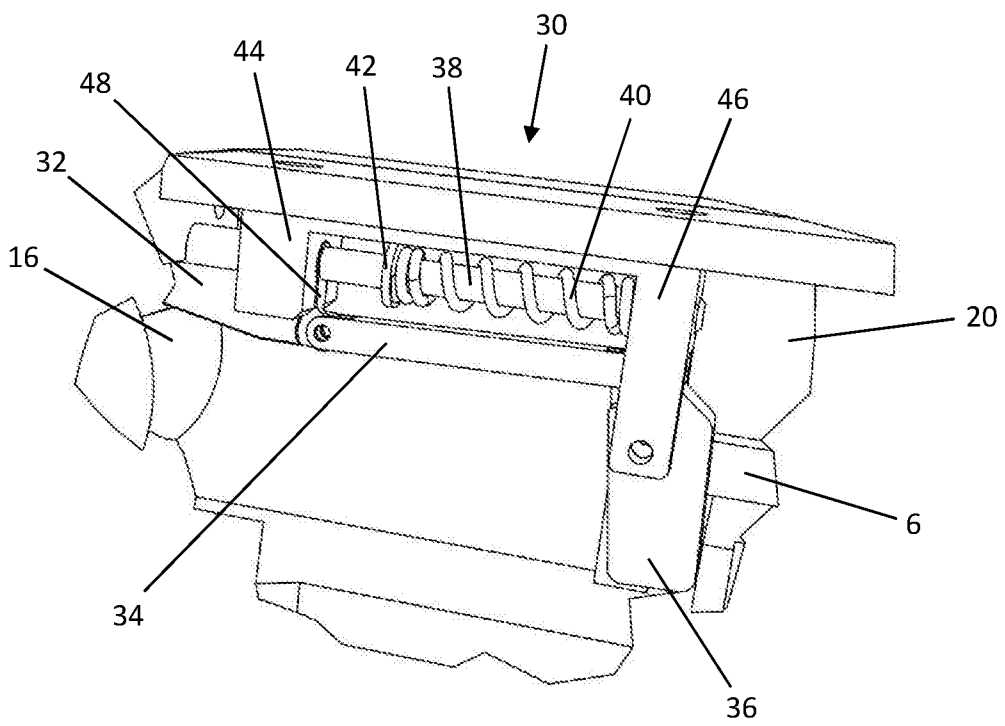
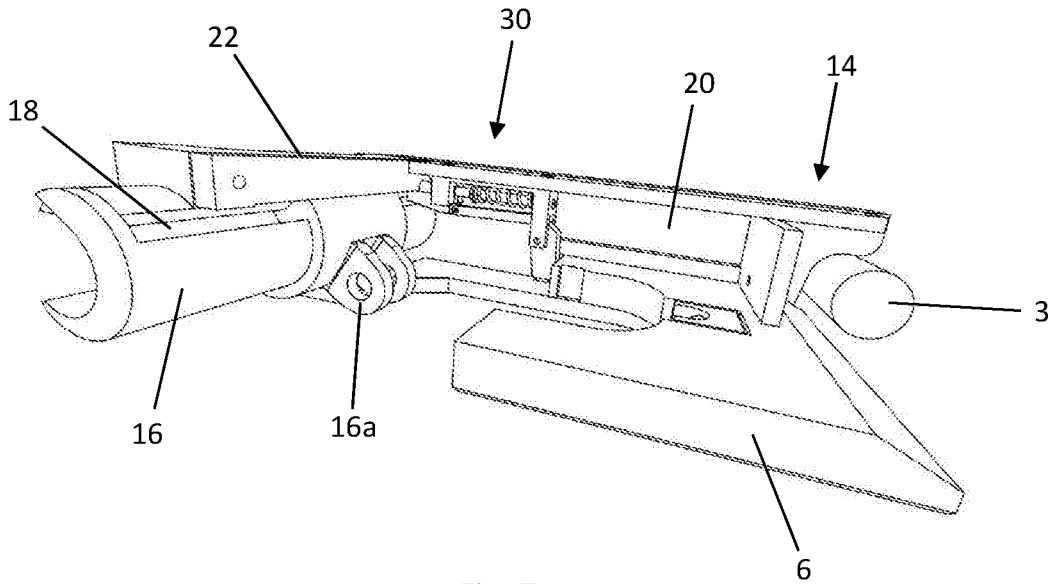

Fig. 6



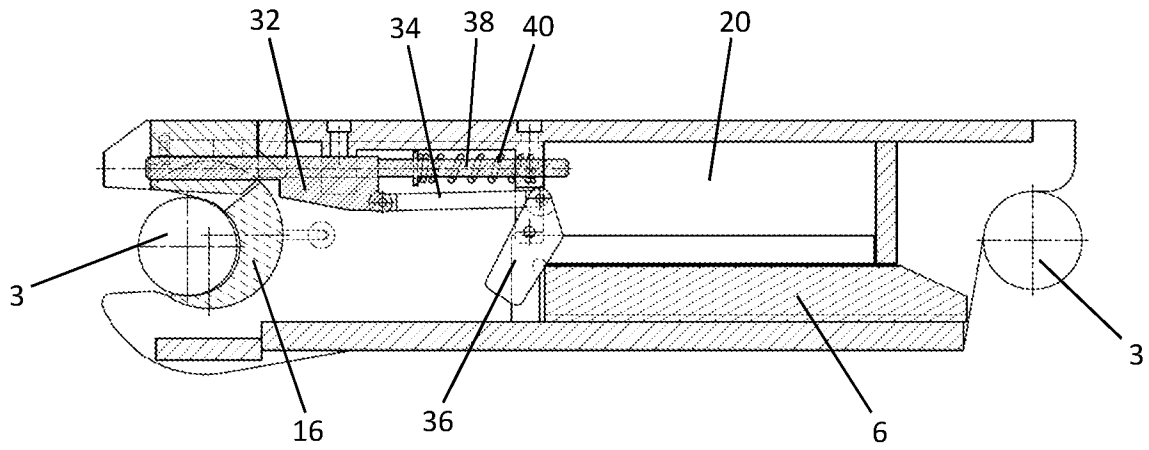

Fig. 9

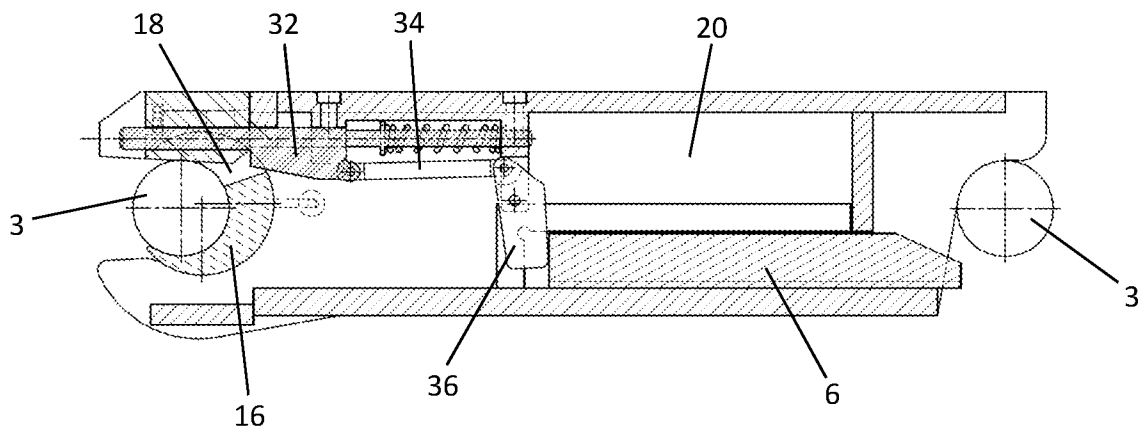

Fig. 10

INTERNATIONAL SEARCH REPORT

International application No.
PCT/NO2014/050093

A. CLASSIFICATION OF SUBJECT MATTER

IPC: see extra sheet

According to International Patent Classification (IPC) or to both national classification and IPC

B. FIELDS SEARCHED

Minimum documentation searched (classification system followed by classification symbols)

IPC: E02F

Documentation searched other than minimum documentation to the extent that such documents are included in the fields searched

SE, DK, FI, NO classes as above

Electronic data base consulted during the international search (name of data base and, where practicable, search terms used)

EPO-Internal, PAJ, WPI data

C. DOCUMENTS CONSIDERED TO BE RELEVANT

| Category* | Citation of document, with indication, where appropriate, of the relevant passages | Relevant to claim No. |
|-----------|---|-----------------------|
| X | WO 2012156672 A1 (SHADOWFICTION LTD ET AL), 22 November 2012 (2012-11-22); page 9, line 4 - page 12, line 11; figures 3-5,8-9 | 1-2 |
| Y | | 6-10 |
| A | -- | 3-5 |
| Y | NO 333221 B1 (HARDNOR AS), 15 April 2013 (2013-04-15); whole document | 1-2, 6-10 |
| A | -- | 3-5 |



Further documents are listed in the continuation of Box C.



See patent family annex.

* Special categories of cited documents:

"A" document defining the general state of the art which is not considered to be of particular relevance

"E" earlier application or patent but published on or after the international filing date

"L" document which may throw doubts on priority claim(s) or which is cited to establish the publication date of another citation or other special reason (as specified)

"O" document referring to an oral disclosure, use, exhibition or other means

"P" document published prior to the international filing date but later than the priority date claimed

"T" later document published after the international filing date or priority date and not in conflict with the application but cited to understand the principle or theory underlying the invention

"X" document of particular relevance; the claimed invention cannot be considered novel or cannot be considered to involve an inventive step when the document is taken alone

"Y" document of particular relevance; the claimed invention cannot be considered to involve an inventive step when the document is combined with one or more other such documents, such combination being obvious to a person skilled in the art

"&" document member of the same patent family

Date of the actual completion of the international search

23-09-2014

Date of mailing of the international search report

24-09-2014

Name and mailing address of the ISA/SE

Patent- och registreringsverket
Box 5055
S-102 42 STOCKHOLM
Facsimile No. + 46 8 666 02 86

Authorized officer

Mariana Eddin

Telephone No. + 46 8 782 25 00

INTERNATIONAL SEARCH REPORT

International application No.
PCT/NO2014/050093

C (Continuation). DOCUMENTS CONSIDERED TO BE RELEVANT

| Category* | Citation of document, with indication, where appropriate, of the relevant passages | Relevant to claim No. |
|-----------|--|-----------------------|
| A | US 20090007465 A1 (ROBL TROY CURTIS ET AL), 8 January 2009 (2009-01-08); paragraphs [0024]-[0025], [0028]-[0029]; figures 1-4 -- | 1-10 |
| A | GB 2467380 A (MILLER INTERNAT LTD), 4 August 2010 (2010-08-04); page 18, paragraph [0003] - page 21, paragraph [0001]; figures 2,4; claims 1, 22, 26 -- | 1-10 |
| A | US 20100124453 A1 (SIKORSKI ROBERT ET AL), 20 May 2010 (2010-05-20); paragraph [0025]; figures 6-7 -- | 1-2, 6-10 |
| A | GB 2330570 A (MILLER RONALD KEITH ET AL), 28 April 1999 (1999-04-28); abstract; figure 13 -- ----- | - |

Continuation of: second sheet
International Patent Classification (IPC)
E02F 3/36 (2006.01)

INTERNATIONAL SEARCH REPORT
Information on patent family members

International application No.
PCT/NO2014/050093

| | | | | | |
|----|----------------|------------|----|----------------|------------|
| WO | 2012156672 A1 | 22/11/2012 | EP | 2710192 A1 | 26/03/2014 |
| | | | GB | 2506777 A | 09/04/2014 |
| | | | WO | 2012156673 A1 | 22/11/2012 |
| NO | 333221 B1 | 15/04/2013 | NO | 20093409 A | 25/05/2011 |
| | | | SE | 1051226 A1 | 25/05/2011 |
| | | | SE | 535735 C2 | 27/11/2012 |
| US | 20090007465 A1 | 08/01/2009 | AU | 2008275755 A1 | 15/01/2009 |
| | | | CN | 101688381 B | 02/01/2013 |
| | | | EP | 2167738 B1 | 14/05/2014 |
| | | | JP | 2010532438 A | 07/10/2010 |
| | | | JP | 5150724 B2 | 27/02/2013 |
| | | | US | 7984575 B2 | 26/07/2011 |
| | | | WO | 2009009000 A3 | 22/05/2009 |
| GB | 2467380 A | 04/08/2010 | GB | 2467383 B | 20/11/2013 |
| | | | US | 20100192425 A1 | 05/08/2010 |
| | | | US | 8112914 B2 | 14/02/2012 |
| US | 20100124453 A1 | 20/05/2010 | US | 8262310 B2 | 11/09/2012 |
| | | | WO | 2010059948 A1 | 27/05/2010 |
| GB | 2330570 A | 28/04/1999 | AT | 259450 T | 15/02/2004 |
| | | | AU | 4527199 A | 27/03/2000 |
| | | | DE | 69914774 T2 | 09/12/2004 |
| | | | DK | 1112413 T3 | 01/06/2004 |
| | | | ES | 2216524 T3 | 16/10/2004 |
| | | | JP | 2002524673 A | 06/08/2002 |
| | | | JP | 3962213 B2 | 22/08/2007 |
| | | | US | 6422805 B1 | 23/07/2002 |
| | | | US | 6481124 B1 | 19/11/2002 |
| | | | WO | 0014342 A1 | 16/03/2000 |