



INTERNATIONAL APPLICATION PUBLISHED UNDER THE PATENT COOPERATION TREATY (PCT)

<p>(51) International Patent Classification⁵ : G01N 33/48, 33/49, 33/86 G01N 15/05</p>	<p>A1</p>	<p>(11) International Publication Number: WO 93/12422</p> <p>(43) International Publication Date: 24 June 1993 (24.06.93)</p>
<p>(21) International Application Number: PCT/DK92/00382</p> <p>(22) International Filing Date: 18 December 1992 (18.12.92)</p> <p>(30) Priority data: 2031/91 19 December 1991 (19.12.91) DK</p> <p>(71) Applicant (for all designated States except US): NOVO NORDISK A/S [DK/DK]; Novo Allé, DK-2880 Bagsværd (DK).</p> <p>(72) Inventors; and</p> <p>(75) Inventors/Applicants (for US only) : HAUCH, Ole [DK/DK]; Ved Ørehøj 2, lejl. 2, DK-2900 Hellerup (DK). KNUDSEN, Jens, Bjerre [DK/DK]; Enebovænge 13, DK-3520 Farum (DK). PLUM, Thomas, Munk [DK/DK]; Skodsborgvej 414, 3. t.v., DK-2942 Skodsborg (DK).</p>		<p>(74) Common Representative: NOVO NORDISK A/S; Patent Department, EIT, Novo Allé, DK-2880 Bagsværd (DK).</p> <p>(81) Designated States: AU, BB, BG, BR, CA, CS, FI, HU, JP, KP, KR, LK, MG, MN, MW, NO, NZ, PL, RO, RU, SD, UA, US, European patent (AT, BE, CH, DE, DK, ES, FR, GB, GR, IE, IT, LU, MC, NL, PT, SE), OAPI patent (BF, BJ, CF, CG, CI, CM, GA, GN, ML, MR, SN, TD, TG).</p> <p>Published <i>With international search report.</i></p>
<p>(54) Title: METHOD AND APPARATUS FOR QUANTITATION OF RELEVANT BLOOD PARAMETERS</p>		
<p>(57) Abstract</p> <p>A method for quantitation of blood parameters comprises the steps provision of a sample of plasma, serum or blood, entering the sample into a cuvette with an internal dimension less than 1 mm, illuminating the sample by a light source, measuring and recording the changes of light properties caused by the sample as a function of time, calculating parameters of the recorded light signal/time curve such as slopes, extreme values, and the time distance between such extreme values, and interpreting the parameters as blood parameters. For the measurements an apparatus is used comprising a cuvette (16, 17) with an internal dimension less than 1 mm, a light source (7, 9), means (8, 10) for measuring currently a light signal from the sample, means for recording the measured light signal values, and means for calculating parameters of the thereby defined light signal versus time graph.</p>		

FOR THE PURPOSES OF INFORMATION ONLY

Codes used to identify States party to the PCT on the front pages of pamphlets publishing international applications under the PCT.

AT	Austria	FR	France	MR	Mauritania
AU	Australia	GA	Gabon	MW	Malawi
BB	Barbados	GB	United Kingdom	NL	Netherlands
BE	Belgium	GN	Guinea	NO	Norway
BF	Burkina Faso	GR	Greece	NZ	New Zealand
BG	Bulgaria	HU	Hungary	PL	Poland
BJ	Benin	IE	Ireland	PT	Portugal
BR	Brazil	IT	Italy	RO	Romania
CA	Canada	JP	Japan	RU	Russian Federation
CF	Central African Republic	KP	Democratic People's Republic of Korea	SD	Sudan
CG	Congo	KR	Republic of Korea	SE	Sweden
CH	Switzerland	KZ	Kazakhstan	SK	Slovak Republic
CI	Côte d'Ivoire	LJ	Liechtenstein	SN	Senegal
CM	Cameroon	LK	Sri Lanka	SU	Soviet Union
CS	Czechoslovakia	LU	Luxembourg	TD	Chad
CZ	Czech Republic	MC	Monaco	TG	Togo
DE	Germany	MG	Madagascar	UA	Ukraine
DK	Denmark	ML	Mali	US	United States of America
ES	Spain	MN	Mongolia	VN	Viet Nam
FI	Finland				

Method And Apparatus For Quantitation Of Relevant Blood Parameters.

The provision of a blood sample for quantitation of various blood parameters is a routine by many medical investigations. Commonly, a sample of
5 some ml is taken and sent to a laboratory where the relevant parameters such as coagulation time, haematocrit, sedimentation rate, haemoglobin percentage, etc are quantified.

To obtain a sample of some ml it is necessary to pass a cannula into a vein to make the necessary amount of blood flow into a vessel. The vessel must
10 then be carefully labelled and sent to the laboratory wherefrom the determined data will issue later.

By this procedure the blood sample when taken must be added an anticoagulant to prevent the blood from coagulating on its way to the laboratory. In the laboratory the effect of the anticoagulant is neutralized to make the sample
15 equate a sample of fresh blood.

It is wanted to provide a method and an apparatus making it possible to decide the relevant parameters on the basis of fresh blood, the measuring beginning practically at the very moment the blood sample leaves the patient's body and being ended about 30 minutes later. The apparatus should be handy and
20 portable to an extent making it possible to allocate the apparatus to the patient so that the blood sample may be passed into the apparatus, which may then be placed at the bedside until the result is ready. Further, the method should make it possible to perform the measurement on a blood sample which may be provided by simply pricking a finger or an earlobe to obtain a sample not larger than 25 μ l, i.e. a sample
25 which could be provided without help from a professional to puncture a vein.

A method of measuring the coagulation time for a blood sample is known, which method comprises the steps of entering the sample into a capillary element and measuring the coagulation time as the time elapsing from the moment when the blood sample enters the photometer measuring the translucence, which
30 moment is indicated by a sudden fall of the translucence, until the moment when the

translucence reaches a maximum after this sudden fall.

However, it has appeared that the development of the properties of light passing through or being scattered or reflected by a blood sample beyond the time of the occurrence of the first translucence maximum reveals interesting information
5 of other relevant blood parameters.

According to the invention, a method for quantitation of relevant blood parameters comprises the following steps:

- provision of a sample of plasma, serum or whole blood,
- entering the sample into a cuvette with an internal dimension less than
10 1 mm,
- illuminating the sample by a light source,
- measuring and recording the changes of light properties caused by the sample as a function of time,
- calculating parameters of the recorded light signal/time curve,
- 15 - interpreting the parameters such as slopes and time spaces between extremes and/or other well-defined points of the obtained light signal/time curve.

A light signal/time curve may have a course with a first sharp extreme value corresponding to the moment when the sample is introduced in the measuring
20 part of the cuvette. If for example the light signal is the translucence of the sample, this extreme value is a minimum. From this minimum the translucence will rise to a maximum being the second extreme value from which it descends again to a relatively flat minimum representing a third extreme value, whereupon it rises again to a fourth extreme value, a high maximum from which it finally descends almost
25 linearly.

The recording of the curve may be made by frequent storing, e.g. once a second, of connected values for measured light signal and time elapsed from a starting moment, mainly defined by the first sudden change in the light signal corresponding to the entering of the sample. These recordings make it possible to
30 define the extreme values and to calculate slopes in different positions on the curve.

However, when only the time elapsed between two incidents is needed, the recording of the intermediate light signal values may be omitted.

The time elapsing from the starting moment until a well-defined point in relation to the second extreme value is taken as an expression of the coagulation
5 time.

The slope of the curve when passing from the first extreme value to the second extreme value may be taken as an expression of the sedimentation rate.

The difference between the first extreme value and the following second extreme value is taken as an expression of the haematocrit value.

10 The slope of the curve when passing from a well-defined point in relation to the second extreme value to a well-defined point in relation to the third extreme value is taken as an expression of the fibrinogen concentration and the platelet-related coagulation activity. As the slope of the curve varies, this value may be more precisely defined as e.g. the slope of its inflection, or the slope may be
15 calculated as the difference between the second extreme value and a third extreme value or between well-defined points in relation to the extreme values divided by the time difference between these two extremes or points.

The time it takes for the light signal curve to pass the third extreme value is calculated as the time interval from the moment when the light signal value
20 passes a set value differing by a predetermined amount from this third extreme value when approaching this value, until the moment when the light signal value passes again this set value after having passed the third extreme value, and this calculated time is taken as an expression of the activity of the fibrinolytic system.

The slope of the light signal curve when passing from a well-defined
25 point in relation to its third extreme value to a well-defined point in relation to its fourth extreme value is taken as an expression of the rate of fibrin degeneration. The difference between the value in a well-defined point in relation to the third extreme value and a well defined point in relation to the fourth extreme value may be taken as an expression of the amount of fibrin in the sample and consequently of the
30 original fibrinogen concentration.

If a reagent is added to the blood sample before the measurement is

performed, this measurement will show how the blood parameters are influenced by the reagent.

An apparatus for performing the method according to the invention comprises a cuvette with an internal dimension less than 1 mm for receiving a blood sample, a light source for illuminating the sample, means for measuring the light signal from the sample in the cuvette, means for recording the measured light signal values, means for calculating the parameters of the recorded light signal versus time curve, and means for displaying the results of this calculation.

Appropriately, the calculation means may further convert the calculated curve values to clinical chemistry quantities.

The cuvette may be a capillary tube, and more cuvettes working in parallel may be provided each having its own measuring channel. This makes it possible to make a control on the measurement by taking it as an indication that the measurement should be rejected if the measuring results from the two parallel channels deviate by more than a preset value. Further, the use of more parallel cuvettes makes it possible to directly compare two samples, e.g. one of the cuvettes may be coated by an active substance whereby a comparison of the samples in the two cuvettes gives an indication of the effect of the active substance.

The cuvettes may be disposable so that after use they may be removed from the apparatus and replaced by new ones. Also, the cuvettes may be mounted in an independent support piece which is designed to be accommodated in the apparatus and after use be removed from the apparatus and disposed of. The cuvettes mounted in the independent support piece may be capillary tubes which are so placed in the support piece that their inlet ends lie closely up against each other. This makes it possible to fill the two capillary tubes simultaneously from the same drop of blood.

The means for measuring the light signal from the samples may comprise a light source and a light sensor placed in a specific geometric relation to each other. The geometry is chosen with regard to which light signal should be measured. If transluence should be measured, connected light sources and sensors are placed opposite each other, whereas a measurement of scattered or

reflected light is preferably measured by a sensor placed so that it would receive no light directly from the light source. It should be noticed that in the last mentioned case the light signal value is low when no sample is in the cuvette to reflect the light and will suddenly rise when the sample enters the cuvette.

5 According to the invention, the apparatus may comprise a microcomputer performing the recording of the light signal values by storing at preset time intervals the measured light signal values, performing the calculations of the curve parameters on the basis of the stored values, and translating the curve parameters into blood parameters.

10 The calculated parameters may be stored in the microcomputer and may be displayed on the display on request.

In the following the invention is described with reference to the drawing, in which

15 Figure 1 shows a perspective illustration of an embodiment of an apparatus with a support element with capillary elements inserted,

Figure 2 schematically shows a cross-sectional view along the line II-II in Figure 1,

20 Figure 3 shows the support element with the capillary elements during the filling of the capillary elements,

Figure 4 shows a translucence versus time curve for a blood sample.

The apparatus shown in Figure 1 corresponds in its construction to the apparatus according to WO 89/06803 meant for determining the coagulation time 25 for a blood sample. The apparatus itself is indicated as a whole by the reference number 1. It comprises a housing 3 with a display 4 on the one side. At one end of the housing 3 there is provided an opening 5 in which a support element carrying capillary elements may be inserted.

30 Figure 2 illustrates how one or more light sources 7, 9, preferably in the form of light diodes, are mounted in the housing 3 in relation to the opening 5. Light

meters, preferably in the form of photodiodes 8, 10, are mounted opposite the light sources 7,9 on the other side of the opening 5.

The apparatus is also provided with a not shown built-in microprocessor controlling the measuring sequence and calculating the blood parameters on the basis of the translucence measured and stored at preset time intervals. The apparatus only differs from the photometer apparatus according to the WO-application by the performances of the built-in computer which should be equipped with the necessary storage capacity and should be programmed to perform the necessary calculations and controlling. Further, the apparatus should be provided with means to call forward on request the stored and calculated data on the display, which display may further be designed to display not only digits but also curves.

Figure 3 shows the support element 2 with two capillary tubes 16 and 17 during the filling of the tubes from a blood drop 21 provided by pricking a finger 20. The support element 2 comprises a support piece 6 which is preferably made from an opaque plastic. The one end of the support piece 6 is tapered to form a wedge 13 to ease the insertion in the opening 5 of the apparatus. The opposite end of the support piece 6 is provided with a pair of extensions 14 forming a finger grip for the handling of the support element. Moreover, the support element is provided with a groove 12 which together with a similar groove on the back side forms a guide for guiding the support element when inserted in the opening 5 of the apparatus. Finally, the support piece 6 is provided with a pair of windows 18 and 19, one behind each of the capillary tubes. These windows are placed so that they are in line with the light beam from the light source to the light sensor when the support element is inserted in the apparatus.

Although in the embodiment just described the capillary elements are described as being capillary tubes, other forms of capillary elements such as transparent sheets with a small distance between them may be used, just as the capillary elements may be individual and designed to be inserted into the apparatus directly without a supporting element. Also a single capillary element may be used, although two are preferred. The capillary elements may also be arranged so that

blood sampling from venous tubes or a-v shunts is facilitated.

Figure 4 shows a translucence versus time curve recorded during the coagulation sequence for a blood sample. The time elapsed is indicated as seconds along the X-axis, and the translucence is indicated as the output voltage in mV from
5 the photo sensor.

When by the capillary effect the blood sample is sucked into the capillary element inserted in the measuring apparatus, it will cover the light beam through the window 18 or 19 when it reaches the part of the capillary element lying abreast of this window. Thereby the light sensed by the corresponding sensor will
10 be damped suddenly, and a sudden fall will be seen on the translucence curve, illustrated at 41. From this minimum the translucence will slowly rise to a maximum 42, as by their gravity the blood cells are precipitated, and the translucent plasma collects above the precipitated substance. In this way the height of the maximum translucence following the first minimum is an indication of the haematocrit, i.e. the
15 maximum 42 is related to the volume of blood cells in relation to the volume of the whole blood.

At the time for the first maximum the blood starts to coagulate and the translucence falls as the fibrin threads cause dispersion of light. The time from the first minimum 41 to the first maximum 42 defines in the known way the coagulation
20 time.

From its first maximum the translucence falls until all fibrinogen is transformed into fibrin. From the minimum 43 hereby defined the translucence will rise again when the fibrinolytic system is activated. The slope of the falling curve may be taken as an indication of the fibrinogen concentration in the substrate. Also the
25 height of the first maximum 42 over the second minimum 43 may be taken as an indication of the fibrinogen value, and unlike the above mentioned slope this indication is not influenced by a possible coating of the capillary element to stimulate the formation of fibrin.

After the passage of the second minimum 43 the fibrin is by the action
30 of plasmin decomposed to fibrin split products, and the sample becomes more translucent. The second minimum is a rather flat one, and a measuring of the time

passing from the moment when the translucence passes a value a preset distance 46 over the minimum 43 until the moment when it reaches the same value during the rising after the minimum may be taken as an indication of how quickly the fibrinolytic system may be activated, i.e. the velocity of transforming plasminogen into plasmin.

5 The points on the translucence curve lying the preset distance 46 over the minimum 43 during the fall and the rise of the curve, respectively, are designated 44 and 45, respectively. As it is not possible to know at forehand the translucence value for the minimum, it is here necessary to look back into the recorded values when the appearance of the -minimum is detected.

10 The slope of the curve for the rising translucence after the second minimum 43 is seen to be proportional with the plasmin concentration, and the height of a second maximum 47 over the second minimum 43 is related to the quantity of fibrin and consequently to the original fibrin concentration.

Having passed its second maximum value, the translucence falls almost
15 linearly.

By recording the translucence at preset time intervals, data are stored making it possible to determine relevant parameters of the translucence/time-curve. In the computer such parameters may be translated into corresponding blood parameters. Another possibility is to make the computer display the curve directly,
20 as many professionals would prefer to make their evaluation from a knowledge of the course of the curve. For others it may be sufficient to know that the different parameters should be maintained within certain intervals.

The determination of the slope of the curve may be made by differentiating. As the slope varies in time, it is necessary to decide what part of the
25 curve should be used when determining this parameter. For the course from the first maximum to the second minimum and from the second minimum to the second maximum the slope of the curve may be determined as the slope of its inflection. The point of inflection may be found by differentiating the function twice.

Although in the example described the translucence of the sample is
30 measured, it is within the scope of the invention to measure the light scattered or in any other way modulated by the presence of the sample. When measuring scattered

light it is appropriate not to place the sensors opposite the light source but rather angularly displaced in relation to such a 180° position. Thereby it is avoided that the sensor receives light directly from the light source, and especially where a capillary tube is used advantage may be taken of the fact that the cylindric tube acts as a lens which may focus the light on the sensor.

It shall be noticed that the time spaces need not be defined as the time elapsing from one extreme value to the next one, but may be defined as the time space between points which are well defined in relation to these values.

CLAIMS

1. A method for quantitation of blood parameters, characterized in, that it comprises the following steps:
- provision of a sample of plasma, serum or whole blood,
 - 5 - entering the sample into a cuvette with an internal dimension less than 1 mm,
 - illuminating the sample by a light source,
 - measuring and recording the changes of light properties caused by the sample as a function of time,
 - 10 - calculating parameters of the recorded light signal/time curve,
 - interpreting the parameters as blood parameters.
2. A method according to claim 1, characterized in, that the recording is made by frequently storing connected values for measured light signal and time elapsed from a starting moment.
- 15 3. A method according to claim 1 or 2, characterized in, that the time for a first extreme value caused by the introduction of the sample into the cuvette is interpreted as the starting moment for the measurement.
- 20 4. A method according to any of the preceding claims, characterized in, that the time elapsing from a starting moment to a well defined point in relation to the second occurring extreme value is taken as an expression of the coagulation time.
5. A method according to any of the preceding claims, characterized in, that the slope of the curve when passing from the first extreme value to the second extreme value is taken as an expression of the sedimentation rate.
- 25 6. A method according to any of the preceding claims, characterized

in, that the height of the curve when passing from the first extreme value to the second extreme value is taken as an expression of the haematocrit.

7. A method according to any of the preceding claims, characterized in, that the difference between a second extreme value and a third extreme value is
5 taken as an expression of the fibrinogen concentration.

8. A method according to any of the preceding claims, characterized in, that the slope of the curve when passing from a second extreme value is taken as an expression of the fibrinogen concentration and platelet related coagulation activity.

10 9. A method according to any of the preceding claims, characterized in, that the time it takes for the light signal curve to pass a third extreme value is calculated as the time interval from the moment when the light signal value passes a set value differing by a predetermined amount from this third extreme value when approaching this value, until the moment when the light signal value again passes
15 this set value after having passed the third extreme value, and this calculated time is taken as an expression of the activity of the fibrinolytic system.

10. A method according to any of the preceding claims, characterized in, that the slope of the light signal curve when passing from a well-defined point in relation to its third extreme value to a well-defined point in relation to its fourth
20 extreme value is taken as an expression of the rate of fibrin degeneration.

11. A method according to any of the preceding claims, characterized in, that the difference between the value in a well-defined point in relation to the third extreme value and a well defined point in relation to the fourth extreme value on the light signal/time curve is taken as an expression of the amount of fibrin in the sample
25 and consequently of the original fibrinogen concentration.

12. An apparatus for quantitation of blood parameters by performing the method according to claims 1-11, characterized in, that it comprises a cuvette with an internal dimension less than 1 mm for receiving a blood sample, a light source for illuminating the sample, means for measuring the light signal from the sample in the cuvette, means for recording the measured light signal values, means for calculating the parameters of the recorded light signal versus time curve, and means for displaying the results of this calculation.

13. An apparatus according to claim 12, characterized in, that the calculation means further converts the calculated curve parameters to blood parameters.

14. An apparatus according to claim 13, characterized in, that the cuvette is a capillary element.

15. An apparatus according to claim 14, characterized in, that the cuvette is a capillary tube.

16. An apparatus according to claim 15, characterized in, that more parallel acting capillary tubes are provided.

17. An apparatus according to any of claims 12 - 16, characterized in, that the cuvette is mounted in a disposable part of the apparatus.

18. An apparatus according to any of claims 12 - 17, characterized in, that the means for measuring the light signal comprises a light source and a light sensor facing each other on opposite sides of the cuvette element.

19. An apparatus according to any of claims 12 - 18, characterized in, that it comprises a microcomputer performing the current recording by storing at preset time intervals the measured translucence values, performing the calculations

of the curve parameters on the basis of the stored values, and translating the curve parameters into blood parameters.

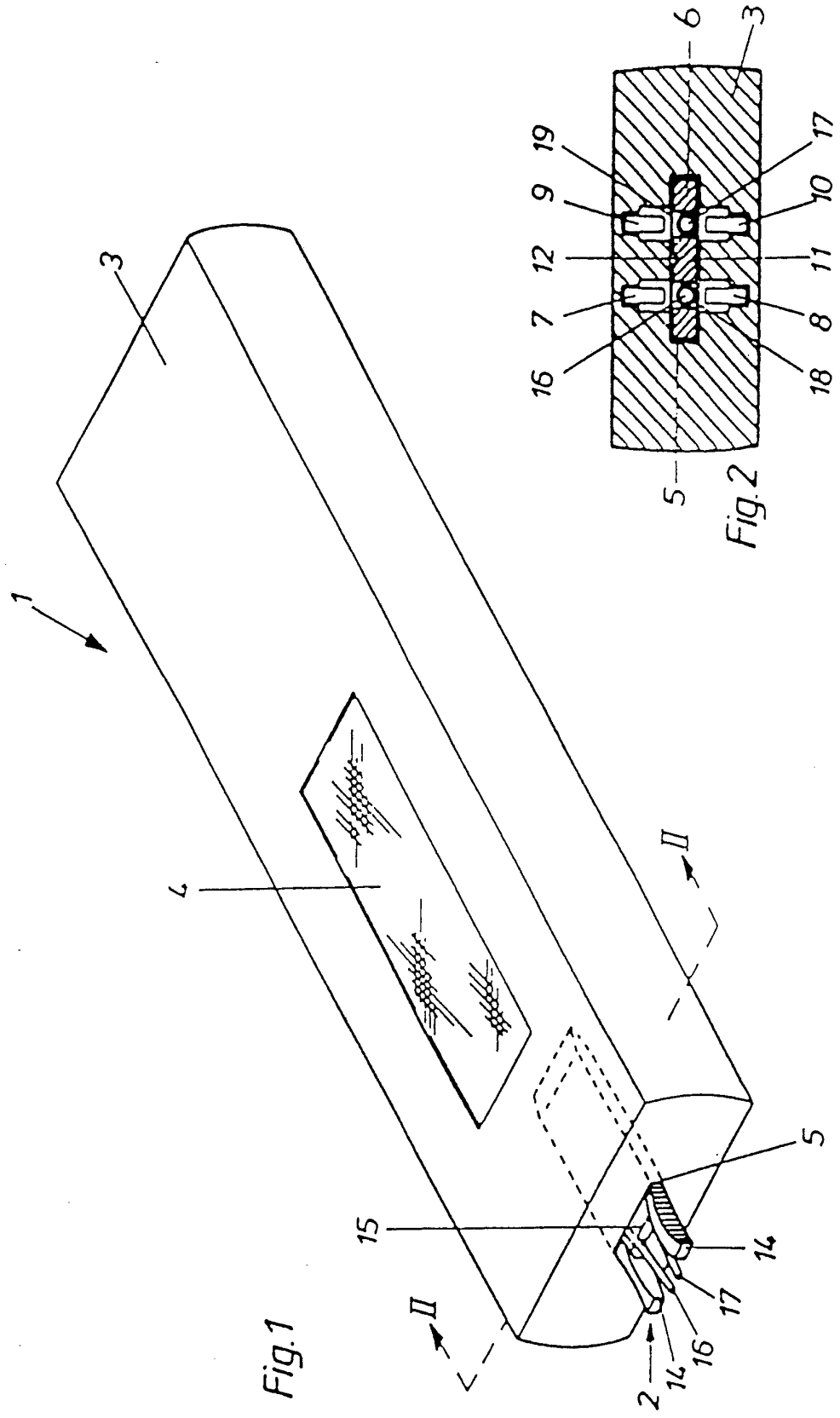

2/2
Fig.3

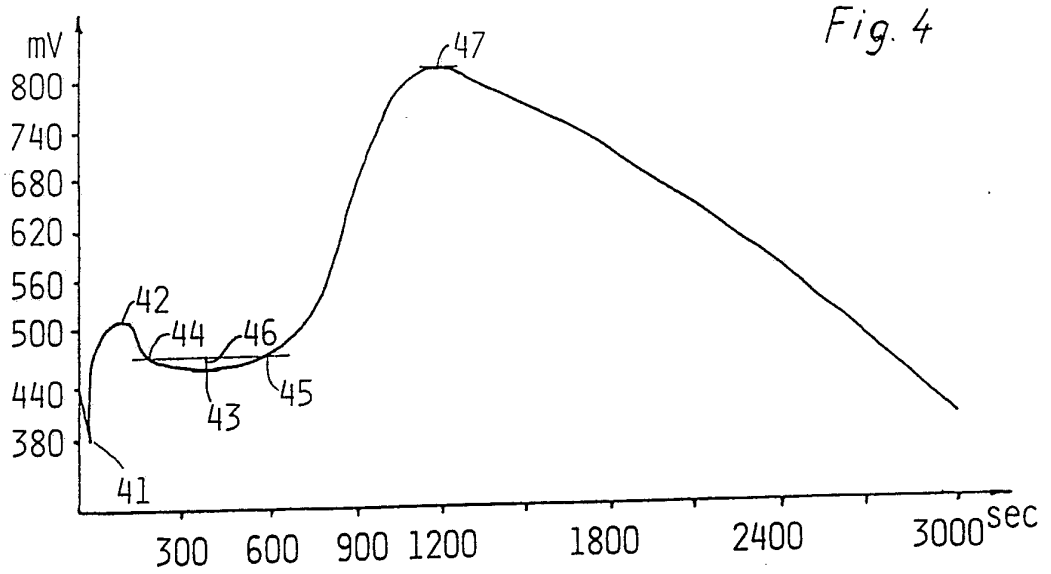
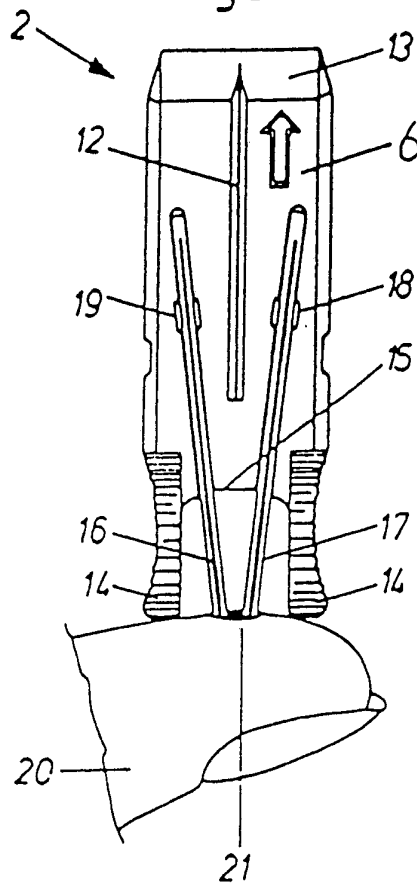

Fig. 4

INTERNATIONAL SEARCH REPORT

International application No.

PCT/DK 92/00382

A. CLASSIFICATION OF SUBJECT MATTER		
IPC5: G01N 33/48, G01N 33/49, G01N 33/86, G01N 15/05 According to International Patent Classification (IPC) or to both national classification and IPC		
B. FIELDS SEARCHED		
Minimum documentation searched (classification system followed by classification symbols)		
IPC5: G01N		
Documentation searched other than minimum documentation to the extent that such documents are included in the fields searched		
SE,DK,FI,NO classes as above		
Electronic data base consulted during the international search (name of data base and, where practicable, search terms used)		
WPI, WPIL, MEDLINE, EMBASE, ANALYTICAL ABSTRACTS		
C. DOCUMENTS CONSIDERED TO BE RELEVANT		
Category*	Citation of document, with indication, where appropriate, of the relevant passages	Relevant to claim No.
X	WO, A1, 8906803 (NORDISK GENTOFTE A/S), 27 July 1989 (27.07.89), see especially claim 1, page 6 line 27 - page 7 line 1, fig 6-7, fig 1 --	1-19
A	US, A, 4848900 (CHENG-DENG KUO ET AL.), 18 July 1989 (18.07.89), see especially the claims --	1-3,5
A	Patent Abstracts of Japan, Vol 9, No 239, P-391, abstract of JP, A, 60-93349 (MOCHIDA SEIYAKU K.K. et al.), 25 May 1985 (25.05.85) --	1-3,6
<input checked="" type="checkbox"/> Further documents are listed in the continuation of Box C. <input checked="" type="checkbox"/> See patent family annex.		
* Special categories of cited documents: "A" document defining the general state of the art which is not considered to be of particular relevance "E" earlier document but published on or after the international filing date "L" document which may throw doubts on priority claim(s) or which is cited to establish the publication date of another citation or other special reason (as specified) "O" document referring to an oral disclosure, use, exhibition or other means "P" document published prior to the international filing date but later than the priority date claimed		"T" later document published after the international filing date or priority date and not in conflict with the application but cited to understand the principle or theory underlying the invention "X" document of particular relevance: the claimed invention cannot be considered novel or cannot be considered to involve an inventive step when the document is taken alone "Y" document of particular relevance: the claimed invention cannot be considered to involve an inventive step when the document is combined with one or more other such documents, such combination being obvious to a person skilled in the art "&" document member of the same patent family
Date of the actual completion of the international search		Date of mailing of the international search report
16 March 1993		19 -03- 1993
Name and mailing address of the ISA/ Swedish Patent Office Box 5055, S-102 42 STOCKHOLM Facsimile No. +46 8 666 02 86		Authorized officer Carolina Palmcrantz Telephone No. +46 8 782 25 00

INTERNATIONAL SEARCH REPORT

International application No.

PCT/DK 92/00382

C (Continuation). DOCUMENTS CONSIDERED TO BE RELEVANT

Category*	Citation of document, with indication, where appropriate, of the relevant passages	Relevant to claim No.
A	Patent Abstracts of Japan, Vol 13, No 138, P-852, abstract of JP, A, 63-305255 (KYOTO DAIICHI KAGAKU K.K. et al.), 13 December 1988 (13.12.88) ----- -----	1-3,7-11

INTERNATIONAL SEARCH REPORT
Information on patent family members

26/02/93

International application No.
PCT/DK 92/00382

Patent document cited in search report	Publication date	Patent family member(s)	Publication date
WO-A1- 8906803	27/07/89	AU-A- 2944889 EP-A- 0403489	11/08/89 27/12/90
US-A- 4848900	18/07/89	NONE	