



(72) JUSTMANN, David Andrae, US

(71) KIMBERLY-CLARK WORLDWIDE, INC., US

(51) Int.Cl.⁶ A44B 18/00, A61F 13/62, A61F 13/56, A41F 1/00

(30) 1996/07/22 (08/681,150) US

(54) **PROCEDE DE FABRICATION D'UN DISPOSITIF DE FIXATION
MECANIQUE**

(54) **PROCESS FOR MAKING A MECHANICAL FASTENER**

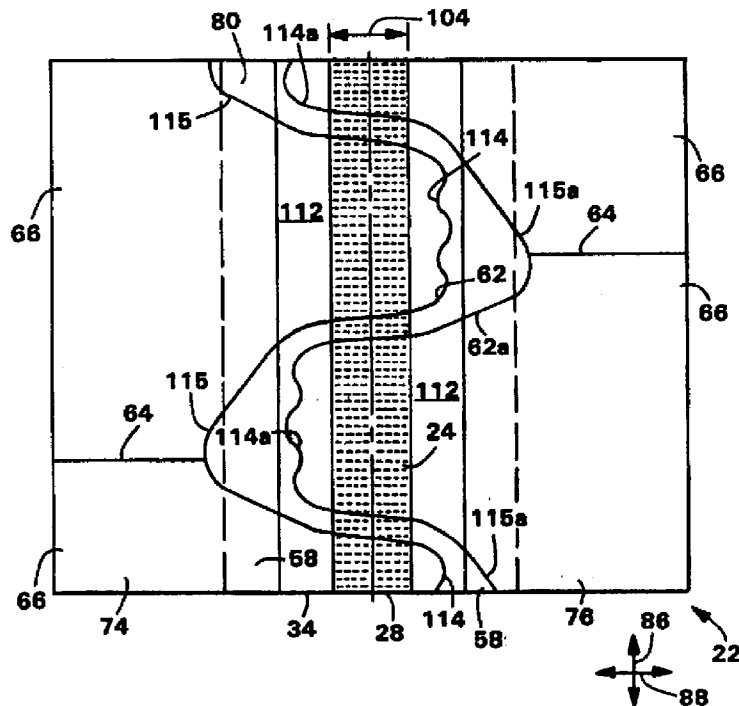

(57) Procédé de fabrication d'une pluralité d'éléments de fixation, consistant à utiliser une bande composite comprenant une bande d'un matériau à crochets. Ce matériau à crochets comprend une couche de base à crochets présentant des première et seconde parties latérales longitudinales et une pluralité de crochets incorporés à la couche de base, qui s'élèvent à partir d'un plan de base de ladite couche de base à crochets. Les crochets sont configurés de façon à s'accoupler activement avec un matériau à boucles coopérant choisi, de sorte que l'on obtienne une fixation active. La bande de matériau à crochets comprend une bande de matériau

(57) A method for forming a plurality of fastener components comprises providing a composite web which includes a web of hook material. The hook material includes a hook base layer which has first and second longitudinally extending side sections and has a plurality of hook elements which are integrally formed with the base layer and extend away from a base plane of the hook base layer. The hook elements are configured to operably engage a selected, cooperating loop material to provide an operative fastening, and the web of hook material has an extending section of carrier web material attached to extend laterally outboard from each of the



support qui y est fixée de façon à s'étendre latéralement à l'extérieur de chacune des parties latérales de la bande de matériau à crochets. Chaque partie de la bande de support comporte une bande formant panneau fixée de façon à s'étendre latéralement à l'extérieur de chaque partie de la bande de support. Cette bande composite est divisée le long d'une première et d'une deuxième ligne de séparation sinueuses qui ne se coupent pas et qui traversent plusieurs fois une largeur complète de la bande à crochets, et qui s'étendent longitudinalement le long d'une région médiane de la bande composite pour former un ruban sinueux qui peut être enlevé et séparé de la bande composite. La première ligne de séparation sinueuse comporte une première pluralité de régions à bosses situées latéralement à l'intérieur et de régions à creux situées à l'extérieur par rapport à ces dernières, qui alternent sur la longueur de la bande composite. La deuxième ligne de séparation comporte une seconde pluralité de régions à bosses situées latéralement à l'intérieur et de régions à creux situées à l'extérieur par rapport à ces dernières, qui alternent sur la longueur de la bande composite. Les régions à bosses des première et seconde lignes de séparation ne s'étendent pas jusque dans les bandes formant panneaux.

side sections of the web of hook material. Each section of carrier web material has an extending web of panel material attached to extend laterally outboard from each section of carrier web material. The composite web is divided along first and second, non-intersecting, serpentine division lines which repeatedly traverse across a complete lateral width of the hook web and extend generally longitudinally along a medial region of the composite web to provide for a serpentine strip which can be removed away and separated from the composite web. The first serpentine division line has a first plurality of laterally inboard hill regions and relatively outboard valley regions which alternate in occurrence along said longitudinal dimension of said composite web. The second serpentine division line has a second plurality of laterally inboard hill regions and relatively outboard valley regions which alternate in occurrence along the longitudinal dimension of the composite web. The hill regions of the first and second serpentine division lines do not extend into the webs of panel material.



PCT

WORLD INTELLECTUAL PROPERTY ORGANIZATION
International Bureau

INTERNATIONAL APPLICATION PUBLISHED UNDER THE PATENT COOPERATION TREATY (PCT)

<p>(51) International Patent Classification ⁶ : A61F 13/62, 13/15</p>	<p>A1</p>	<p>(11) International Publication Number: WO 98/03140 (43) International Publication Date: 29 January 1998 (29.01.98)</p>
<p>(21) International Application Number: PCT/US97/10203 (22) International Filing Date: 19 June 1997 (19.06.97) (30) Priority Data: 08/681,150 22 July 1996 (22.07.96) US (71) Applicant: KIMBERLY-CLARK WORLDWIDE, INC. [US/US]; 401 North Lake Street, Neenah, WI 54956 (US). (72) Inventor: JUSTMANN, David, Andrae; 108 Harris Way, Hortonville, WI 54944 (US). (74) Agents: YEE, Paul, Y. et al.; Kimberly-Clark Worldwide, Inc., 401 North Lake Street, Neenah, WI 54956 (US).</p>	<p>(81) Designated States: AL, AM, AT, AU, AZ, BA, BB, BG, BR, BY, CA, CH, CN, CU, CZ, DE, DK, EE, ES, FI, GB, GE, HU, IL, IS, JP, KE, KG, KP, KR, KZ, LC, LK, LR, LS, LT, LU, LV, MD, MG, MK, MN, MW, MX, NO, NZ, PL, PT, RO, RU, SD, SE, SG, SI, SK, TJ, TM, TR, TT, UA, UG, UZ, VN, ARIPO patent (GH, KE, LS, MW, SD, SZ, UG, ZW), Eurasian patent (AM, AZ, BY, KG, KZ, MD, RU, TJ, TM), European patent (AT, BE, CH, DE, DK, ES, FI, FR, GB, GR, IE, IT, LU, MC, NL, PT, SE), OAPI patent (BF, BJ, CF, CG, CI, CM, GA, GN, ML, MR, NE, SN, TD, TG).</p> <p>Published <i>With international search report. Before the expiration of the time limit for amending the claims and to be republished in the event of the receipt of amendments.</i></p>	

(54) Title: PROCESS FOR MAKING A MECHANICAL FASTENER

(57) Abstract

A method for forming a plurality of fastener components comprises providing a composite web which includes a web of hook material. The hook material includes a hook base layer which has first and second longitudinally extending side sections and has a plurality of hook elements which are integrally formed with the base layer and extend away from a base plane of the hook base layer. The hook elements are configured to operably engage a selected, cooperating loop material to provide an operative fastening, and the web of hook material has an extending section of carrier web material attached to extend laterally outboard from each of the side sections of the web of hook material. Each section of carrier web material has an extending web of panel material attached to extend laterally outboard from each section of carrier web material. The composite web is divided along first and second, non-intersecting, serpentine division lines which repeatedly traverse across a complete lateral width of the hook web and extend generally longitudinally along a medial region of the composite web to provide for a serpentine strip which can be removed away and separated from the composite web. The first serpentine division line has a first plurality of laterally inboard hill regions and relatively outboard valley regions which alternate in occurrence along said longitudinal dimension of said composite web. The second serpentine division line has a second plurality of laterally inboard hill regions and relatively outboard valley regions which alternate in occurrence along the longitudinal dimension of the composite web. The hill regions of the first and second serpentine division lines do not extend into the webs of panel material.

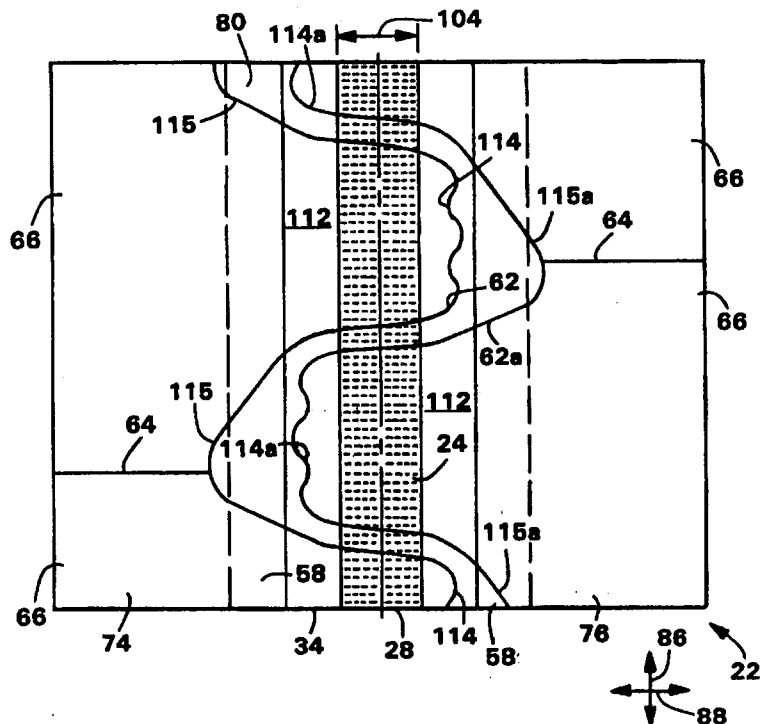

PROCESS FOR MAKING A MECHANICAL FASTENER

Field of the Invention

- 5 The present invention relates to a technique for forming a fastening system. More particularly, the invention relates to a technique for forming an article having a side panel member connected to a fastening system which incorporates a distinctive grip tab.

Background of the Invention

10

Conventional absorbent articles, such as disposable diapers, have been constructed with elasticized waistbands. Particular article designs have incorporated a stretchable outer cover composed of an elastomeric web material, such as a stretch bonded laminate which includes a layer of nonwoven fabric. Other conventional designs have included
15 elastomeric or nonelastomeric side panel members connected to the lateral side edges of an outercover composed of a polymer film material, and fasteners and fastening tabs have been connected and attached to the side panels for securing the article on a wearer. The fastener tabs can include mechanical fastening mechanisms, such as the complementary components of a hook-and-loop fastener.

20

Conventional techniques have been employed for forming articles which have fastening systems with shaped side-panel members having desired edge contours. Particular techniques have been configured to remove a continuous die-cut strip from the middle region of a web of side panel material having strips of a mechanical fastener component
25 attached thereto. Conventional processes, such as those described above, have, however, exhibited significant shortcomings when incorporated into desired, high speed manufacturing operations. For example, the process arrangements have required the use of excessive amounts of side panel material, which can be expensive and may create excessive thickness. The processes have also provided fastener web
30 constructions which have insufficient integrity or have been excessively bulky or difficult to handle during subsequent operations. As a result, it has been difficult to provide a technique for reliably and efficiently producing a mechanical fastening system which has a desired contoured shape, and desired performance characteristics. There has been a continued need for an improved manufacturing technique which can more efficiently
35 produce an article having a more reliable and lower cost fastening system.

Brief Description of the Invention

A process aspect of the invention provides a method for forming fasteners. The method includes providing a composite web which includes a web of a first mechanical fastening component. The first mechanical fastening component includes a base layer which has first and second, laterally opposed, longitudinally extending side sections, and has a plurality of first mechanical fastening elements which are integrally formed with the base layer and extend away from a base plane of the base layer. The first mechanical fastening elements are configured to operably engage a selected, cooperating second mechanical fastening component. The web of the first mechanical fastening component may have an extending section of carrier web material attached to extend laterally outboard from each of the side sections of the first mechanical fastening component web, and each section of carrier web material may include a web of panel material attached to extend laterally outboard from said each section of carrier web material. The composite web is divided along first and second, non-intersecting, serpentine division lines which repeatedly traverse across a substantially complete lateral width of the first mechanical fastening component web and extend generally longitudinally along a medial region of the composite web to provide for a serpentine strip which may be removed away from the composite web. The first serpentine division line has a first plurality of laterally inboard hill regions and relatively outboard valley regions which alternate in occurrence along the longitudinal dimension of said composite web. The second serpentine division line has a second plurality of laterally inboard hill regions and relatively outboard valley regions which alternate in occurrence along the longitudinal dimension of the composite web. Desirably, the hill regions of the first and second serpentine division lines do not extend into the webs of panel material.

In particular aspects of the invention, the composite web may be selectively segmented to provide for the plurality of fastener components, and in further aspects, the valley regions of the serpentine lines can extend into the webs of panel material. The various aspects of the invention can advantageously provide an improved technique for forming a fastener system in which a shaped fastener tab can provide a desired ease of opening while also providing a secure closure which is resistant to premature pop-opens. With the technique, the fastening system can be manufactured at high speed, and the resultant fastener tab can be more effectively and efficiently produced without leaving undesired whiskers or other poorly attached pieces. As a result, the present invention, in its various configurations, can provide an improved technique for forming an article

having a more effective and reliable fastening system. The resultant article and fastening system can have more consistent quality and can provide more dependable performance.

5 Brief Description of the Drawings

The invention will be more fully understood and further advantages will become apparent when reference is made to the following detailed description and accompanying drawings in which:

10

Fig. 1 representatively shows a schematic, perspective view of a portion of the method and apparatus of the invention;

15

Fig. 2 a schematic, perspective view of another portion of the method and apparatus of the invention;

Fig. 3 representatively shows a schematic composite web and its associated components;

20

Fig. 4 representatively shows an expanded, schematic cross-sectional, lateral end view of the composite web illustrated in Fig. 3;

Fig. 5 representatively shows an alternative configuration of the method and apparatus of the invention for making multiple composite webs;

25

Fig. 6 representatively shows a further, schematic composite web assembly and its associated components;

30

Fig. 7 representatively shows an expanded, schematic cross-sectional, lateral end view of the composite web assembly illustrated in Fig. 6.

Detailed Description of the Invention

The method and apparatus of the present invention will be described herein in
35 relationship to their use in producing a fastener system for absorbent articles, particularly disposable absorbent articles. Such articles can be placed against or in proximity to the

body of a wearer to absorb and contain various exudates discharged from the body, and are intended to be discarded after a limited period of use. The articles are not intended to be laundered or otherwise restored for re-use. While the present description will particularly be made in the context of a diaper article, it should be understood that the present invention is also applicable to other articles, such as caps, gowns, drapes, covers, adult incontinence garments, sanitary napkins, children's training pants, and the like.

In particular arrangements, the present invention can advantageously be employed to more efficiently produce a fastening system for incorporation into an absorbent article, such as a disposable diaper having a front waistband section, a rear waistband section and an intermediate section which interconnects the front and rear waistband sections. The article includes a backsheet layer, and a liquid permeable topsheet layer which is superposed on and connected to the backsheet layer. An absorbent body is located between the backsheet layer and the topsheet layer, and a fastening system is connected to the article at each laterally opposed end region of at least one of the front and rear waistband sections. Each fastening system can include a side panel member, and the side panels can optionally be constructed to be elastomerically stretchable at least along a lateral, cross-direction of the article. A fastening tab for securing the article on a wearer is connected to each of the side panels.

Articles which include elastomeric side panels and selectively configured fastener tabs are described in U.S. Patent Application Serial No. 168,615 of T. Roessler et al., entitled DYNAMIC FITTING DIAPER, and filed December 16, 1993 (attorney docket No. 10,961); and in U.S. Patent Application Serial No. 603,477 of A. Long et al., entitled MECHANICAL FASTENING SYSTEM WITH GRIP TAB, and filed March 6, 1996 (attorney docket No. 12,563). Various techniques for forming the fastening systems are described in U.S. Patent No. 5,399,219 of T. Roessler et al., entitled METHOD FOR MAKING A FASTENING SYSTEM FOR A DYNAMIC FITTING DIAPER and issued March 21, 1995 (attorney docket No. 11,186); in U.S. Patent Application Serial No. 286,086 of D. Fries, entitled A PROCESS FOR ASSEMBLING ELASTICIZED EAR PORTIONS and filed August 3, 1994 (attorney docket No. 11,169); and in U.S. Patent Application Serial No. 08/415,383 of D. Fries et al., entitled AN ASSEMBLY PROCESS FOR A LAMINATED TAPE and filed April 3, 1995 (attorney docket No. 11,950). The entire disclosures of the above-mentioned documents are incorporated herein by reference in a manner that is consistent (not in conflict) herewith.

The present invention can provide a distinctive technique for forming a fastener system having a selected, composite fastener component. The invention can further provide a distinctive technique for forming a selected article, such as an elasticized disposable diaper which includes a fastening system. With reference to Figs. 1, 2, 3 and 4, a method and apparatus of the invention, shown generally at 20, for forming a plurality of fastener components 66 includes a providing of a composite web 22 which includes a web of a first mechanical fastening component, such as a web of hook material 24. The first mechanical fastening component web includes a base layer, such as hook base layer 26, which has laterally opposed, longitudinally extending side sections 30 and 32. The base layer also has a plurality of mechanical fastening elements, such as hook elements 54, which are integrally formed with the base layer 26 and extend away from a base plane which is generally defined by the base layer. The first mechanical fastening elements are configured to operably engage a selected, cooperating second mechanical fastening component, such as a conventional loop material. The web of the first mechanical fastening component can have extending sections of the carrier web material, such as carrier web sections 38 and 40, attached to extend laterally outboard from each of the side sections 30 and 32 of the first mechanical fastening component web. In particular, carrier web section 38 extends laterally outboard from the fastening side section 30, and carrier web section 40 extends laterally outboard from the fastening side section 32. Each section 38 and 40 of carrier web material can include a web of panel material, such as panel web section 74 or 76, attached to extend laterally outboard from its associated section of carrier web material. The resulting composite web 22 is divided along a first serpentine division line 62 and a second serpentine division line 62a, which are non-intersecting. The serpentine division lines repeatedly traverse across a substantially complete lateral width 104 of the first mechanical fastening component web and extend generally longitudinally along a medial region 28 of the composite web 22 to provide for a serpentine strip 80 which can be removed away and separated from the composite web. The first serpentine division line 62 has a first plurality of laterally inboard hill regions 114 and relatively outboard valley regions 115 which alternate in occurrence along the longitudinal dimension 86 of the composite web 22. The second serpentine division line 62a has a second plurality of laterally inboard hill regions 114a and relatively outboard valley regions 115a which alternate in occurrence along the longitudinal dimension of the composite web. Desirably, the first and second serpentine division lines are substantially coextensive, and the hill regions 114 and 114a of the first and second serpentine division lines do not extend into the webs of panel material 56.

In particular aspects, the valley regions 115 and 115a of the serpentine lines can be configured to extend into the webs of panel material. In further aspects of the invention, the composite web 22 can be selectively segmented along segmenting lines 64 to provide the plurality of fastener components 66. The fastener components can then be
5 attached to side regions of an appointed article web, and the article web can be separated into a plurality of individual articles, such as diaper articles.

With respect to the shown arrangement, the first mechanical fastening component provides hook elements 54 which are configured to operably engage the selected,
10 cooperating second mechanical fastening component provided by an operable loop material. The hook material web is connected at a location between the extending sections of carrier web material 38 and 40, one of which is attached to extend laterally outboard from each of the side sections 30 and 32 of the web of hook material 24. At least the web of hook material 24 is divided along the serpentine division lines 62
15 and 62a which extend generally longitudinally along the web of hook material 24. As illustrated in the shown configurations, each of the division lines can also divide the carrier web 34 and can have portions which extend to divide the webs 56 of panel material.

20 It should be readily appreciated that the loop material may be employed as the first mechanical fastening component and that the first mechanical fastening elements may be provided by loop elements. In a corresponding, complementary fashion, the hook material may be employed as the second mechanical fastening component.

25 In the shown arrangement, the method is arranged to provide a composite web 22 having an extending, side panel web sections 74 and 76, which are constructed of an elastomerically stretchable panel material and are attached to extend laterally outboard from each of the sections 38 and 40, respectively, of the carrier web material 34. The panel material is elastomerically extensible along at least the lateral cross-direction 88 of
30 the panel material.

The shown arrangement of the method and apparatus also incorporates a single carrier web onto a surface of which a hook material web 24 is laminated and secured. As a result, the serpentine division lines 62 and 62a operably divides the hook material 24, the
35 carrier material web 34, and the panel web sections 74 and 76. Alternatively, the hook material web 24 may be positioned in-between a pair of laterally spaced apart carrier

webs 34, and operably laminated and secured to the carrier webs. Accordingly, each of the individual carrier webs has first and second, laterally opposed side regions thereof. The first side region of each carrier web is attached to the web of hook material 24, and the second side region of each carrier web is operably attached to the outboard edge
5 portion of its correspondingly associated side panel web section.

The representatively shown method and apparatus generally has a longitudinal, machine-direction 86 and a lateral, cross-direction 88. At any particular, selected location along the method and apparatus, the machine-direction is the generally length-wise
10 direction along which a particular web (or composite web) of material is moving or transported through the process. The cross-direction extends generally along the plane of the web of material, and is perpendicular to the particular machine-direction established by the method or apparatus at the selected location.

15 During the process of assembling the various described components, particular attaching or bonding mechanisms may be mentioned. It should be readily appreciated, however, many alternative mechanisms may also be employed. Such alternative techniques include, for example, ultrasonic bonding, thermal bonding, adhesive bonding, pressure bonding, laser bonding, microwave bonding and the like, as well as combinations thereof.

20 With regard to the shown configuration, the method for forming a plurality of fastener components includes providing a substantially continuous web of hook material along a selected longitudinal dimension 86. The hook material includes a hook base layer 26 which has first and second, laterally opposed, longitudinally extending side sections 30
25 and 32, and is configured with mechanical fastening elements to provide a primary fastening section of the web 24. In the representatively shown arrangements, the hook material has a plurality of hook elements 54 which are integrally formed with the base layer 26 and extend away from a base plane which is generally defined by the hook base layer. The hook elements 54 are configured to operably engage a selected, cooperating
30 loop material, such as loop material composed of an operative woven, nonwoven or knitted fabric. At least one substantially continuous web 34 of carrier material is attached to the web of hook material 24 to provide for an extending section of carrier web material which extends laterally outboard from each of the side sections 30 and 32 of the hook material web 24. A substantially continuous web of panel material 56 is attached to
35 extend laterally outboard from each extending section of carrier web material, thereby forming a composite fastener web 22. At least the web of hook material 24 is divided

along the serpentine division lines 62 and 62a, which are non-intersecting and extend generally longitudinally along the web of hook material 24. Each of the serpentine lines 62 and 62a has generally longitudinally extending portions 61 and generally laterally extending portions 63 (Fig. 3). In addition, each of the serpentine division lines

5 repeatedly traverses across a complete lateral width 104 of the web of hook material 24 and extend generally longitudinally along a medial region 28 of the composite web 22 to provide for a serpentine strip 80. The first serpentine division line 62 has a first plurality of laterally inboard hill regions 114 and relatively outboard valley regions 115 which alternate in occurrence along the longitudinal dimension 86 of the composite web 22.

10 The second serpentine division line 62a has a second plurality of laterally inboard hill regions 114a and relatively outboard valley regions 115a which alternate in occurrence along the longitudinal dimension of the composite web. Desirably, the hill regions 114 and 114a of the first and second serpentine division lines do not extend into the webs of panel material 56, and the serpentine strip 80 can be removed away from the composite

15 web. In a particular aspect the valley regions 115 and 115a of the first and second serpentine division lines are arranged to extend into the webs of panel material 56.

The various configurations of the invention can advantageously reduce the occurrence of undesired slivers or whiskers of carrier material 34 on the fastener components 66 which

20 are produced from the composite web 22. In addition, the various configurations of the invention can avoid the occurrence of an extraneous piece of panel material connected to the distal free-end of the fastener component at a location generally adjacent the region of hook material or other first mechanical fastening component. As a result, the invention can more effectively produce fastening components with better defined

25 contour-shape and improved integrity during high speed manufacturing operations.

With reference to Figs. 1, 2, 3 and 4, a supplying means, such as supply roll 57, provides a first, panel web 56 composed of a selected panel material. The panel material may be substantially nonelastomeric or may be elastomeric. In particular configurations of the

30 invention, the side panel material is composed of an elastomeric material which is elastically stretchable at least along the cross-direction 88 of the panel web 56. The panel material can, for example, be a stretch-bonded-laminate (SBL) material, a neck-bonded-laminate (NBL) material, an elastomeric film, an elastomeric foam material, or the like. For example, suitable meltblown elastomeric fibrous webs for forming panel web 56

35 are described in U.S. Patent 4,663,220 issued May 5, 1987 to T. Wisneski et al., the entire disclosure of which is hereby incorporated by reference. Examples of composite

fabrics comprising at least one layer of nonwoven textile fabric secured to a fibrous elastic layer are described in European Patent Application EP No. 0 110 010 published on April 8, 1987 as EP 0 217 032 A2, with the inventors listed as J. Taylor et al., the entire disclosure of which is hereby incorporated by reference. Examples of NBL
5 materials are described in U.S. Patent 5,226,992 issued July 13, 1993 to M. Mormon, the entire disclosure of which is hereby incorporated by reference. A particular neck-bonded-laminate (NBL) can be composed of a film of elastomer material sandwiched between two layers of spunbond material. The film can be composed of a KRATON® elastomer available from Shell Oil Company, and the spunbond layers can be composed of
10 spunbond, polypropylene fibers.

A suitable separating mechanism, such as a slit or other cutter 52, is employed to divide the panel web 56 into a first panel web section 74 and a second panel web section 76. In the illustrated configuration, for example, slit 52 can separate the panel
15 web 56 into first and second sections which have substantially equal cross-directional widths. Optionally, the separated web sections 74 and 76 can have unequal cross-directional widths, as desired. Each of the panel web sections has an inboard side edge region 58 and an outboard side edge region 60.

20 The relative positioning of the first and second web sections 74 and 76, respectively, is adjusted to a desired spacing along the cross-deckle direction 88 of the process by an operable directing means, such as provided by a spreader mechanism 78. In the illustrated embodiment, for example, the spreader mechanism can include a conventional system of turn bars which reposition and relocate the first and second webs of side panel
25 material at a desired spacing therebetween. For example, the spreader mechanism 78 can include a first pair of turn bars which are tilted and canted in a manner well known to the art to produce the desired repositioning of the first panel web section 74. The first panel web section 74 moves in an S-shaped path to pass over its first, top turn bar and then pass back and under its second, bottom turn bar to become offset by a
30 predetermined distance away from second panel web section 76.

Similarly, a conventional second set of turn bars can be tilted and canted at appropriate angles in a manner well known in the art to selectively reposition the second panel web section 76. In particular, the second panel web section can be moved in another
35 S-shaped path to pass over its first, top turn bar and then pass back and under its

second, bottom turn bar in a manner which directs the second panel web section 76 to a position that is spaced the desired distance away from first panel web section 74.

Alternative spreader mechanisms include, for example, conventional guiding roller
5 systems, such as those distributed by FIFE Corporation, a business having offices located in Oklahoma City, Oklahoma; and bowed rotating rolls, such as those distributed by Mt. Hope Machine Co., a business having offices in Taunton, Massachusetts. Examples of other spreader mechanisms include non-parallel systems of rollers or bars, bowed non-rotating bars, grooved spreader rollers, crowned rollers and the like.

10

After the spreader mechanism has generated the desired lateral, cross-directional spacing between the first panel web section 74 and the second panel web section 76, the two panel web sections are directed to a second assembling means, such as provided by a system of assembly rollers 50.

15

A second supplying means, such as supply roll 23, supplies a web of the selected, first mechanical fastening component, such as the illustrated web 24 of hook material. The hook material web includes a base layer 26, and defines a first side section 30 and a second side section 32. In addition, the base layer 26 has a first surface 46 and an
20 oppositely located second surface 48. The first surface 46 is typically appointed to be inwardly facing of the associated article, and includes a plurality of fastening elements projecting and extending therefrom. The shown arrangement of the supply roll 23 has the hook elements extending radially outwardly from the supply roll. In particular aspects of the invention, the fastening elements are integrally formed with the base layer 26 and
25 can be composed of substantially the same material as the base layer. Desired configurations include hook elements which are coextruded or otherwise integrally formed from the base layer material.

In particular aspects of the invention, the web of hook material 24 can be of the type
30 referred to as micro-hook material. A suitable micro-hook material is distributed under the designation CS200 and is available from 3M Company, a business having offices in St. Paul, Minnesota. The micro-hook material can have hooks in the shape of mushroom "caps", and can be configured with a hook density of about 1600 hooks per square inch; a hook height which is within the range of about 0.033 - 0.097 cm (about 0.013 to 0.038
35 inch); and a cap width which is within the range of about 0.025 - 0.033 cm (about 0.01 to

0.013 inch). The hooks are attached to a base film substrate having a thickness of about 0.0076- 0.01 cm (about 0.003-0.004 inch) and a Gurley stiffness of about 15 mg. Another suitable micro-hook material is distributed under the designation VELCRO CFM 29 1058, and is available from VELCRO U.S.A., Inc. , a business having offices in
5 Manchester, New Hampshire. The micro-hook material can have hooks in the shape of angled hook elements, and can be configured with a hook density of about 264 hooks per square centimeter (about 1700 hooks per square inch); a hook height which is within the range of about 0.030 - 0.063 cm (about 0.012 - 0.025 inch); and a hook width which is within the range of about 0.007 to 0.022 cm (about 0.003 to 0.009 inch). The hook
10 elements are coextruded with a base layer substrate having a thickness of about 0.0076 - 0.008 cm (about 0.003 - 0.0035 inch) and the member of hook material has a Gurley stiffness of about 12 mg.

With reference again to Figs. 1, 2, 3 and 4 , at least one carrier web 34 is delivered from
15 a suitable source, such as supply roll 35. In particular configurations of the invention, the material of carrier layer 56 can be composed of a substantially non-elastomeric material, such as polymer films, woven fabrics, nonwoven fabrics or the like, as well as combinations thereof. Alternatively, the carrier web material may be composed of a substantially elastomeric material, such as a stretch-bonded-laminate (SBL) material, a
20 neck-bonded-laminate (NBL) material, an elastomeric film, an elastomeric foam material, or the like, as well as combinations thereof. The elastomeric material is elastomerically stretchable at least along the lateral dimension 88. For example, the carrier web material may be composed of a spunbond-meltblown-spunbond (SMS) fabric having a core of meltblown fibers sandwiched between two facing layers of spunbond fibers to provide a
25 total composite basis weight within the range of about 50 - 67 g/m² (about 1.5 - 2 oz/yd²). As another example, the carrier web material may be entirely composed of a nonwoven spunbond fabric having a basis weight within the range of about 50 - 67 g/m² (about 1.5 - 2 oz/yd²).

30 As representatively shown, the carrier web 34 has a first major facing surface 42 and a second major facing surface 44. The carrier web also has a first side section 38, a second side section 40, and a medial section 36 which is interposed between the first and second side sections of the carrier web and is positioned generally along a longitudinal centerline of the carrier web. The second surface 48 of the web of hook
35 material 24 is operably bonded and laminated to the medial portion 36 of the first surface 42 of the carrier web to provide a composite fastener web 72. An operative attaching

mechanism, such as the shown adhesive applicator 82, generates an attachment for operably affixing the hook material web 24 to the associated carrier web 34, and a conventional assembly mechanism, such as a system of rollers 84, mount the hook material onto the carrier web. The applicator can be configured to generate any
5 conventional arrangement of adhesive, such as a slot coating, a bead, a spray, a swirl pattern or the like, as well as combinations thereof. Desirably, the hook material web is substantially centered along the cross-direction of the carrier web 34. The resultant assembly provides a composite web laminate in which the hook elements 54 are in a generally exposed position. The composite fastener web 72 can then be operably
10 directed and transported for further processing.

In the representatively shown configuration of the invention, suitable directing means, such as a conventional system of guiding rollers 50, transport the fastener web 72 to a position which is interposed between the panel web sections 74 and 76. A suitable
15 attaching mechanism, such as the shown system of adhesive applicator 90 and ultrasonic bonder 92, generates an attachment for affixing the composite fastener web 72 in between the laterally spaced-apart, panel web sections 74 and 76 to provide the composite web 22. More particularly, the adhesive applicator initially attaches outboard edges of the composite web 72 to associated, overlapping edges of each of
20 the panel web sections 74 and 76. The inboard edge region 58 of the first panel web section 74 attaches to the overlapping first side edge region 39 of the first side section 38 of the carrier web 34, and the inboard edge region 58 of the second panel web section 76 attaches to the overlapping second side edge region 41 of the second side section 40 of the carrier web. The shown arrangements laminate the panel webs onto
25 the first surface 42 of the carrier web 34. Alternatively, the panel webs may be laminated onto the opposite, second surface 44 of the carrier web. The sonic bonder can desirably be employed to supplement the initial attachments with sonic, thermal bonds. The sonic bonder can also generate an attachment between the hook material 24 and the carrier web 34, which together have provided the composite web 72.

30

The composite web can then be moved or otherwise directed for further processing. For example, the composite web 22 may be wound onto rolls, such as storage rolls 124, or otherwise configured for transport to another, remotely located manufacturing line which is employed to produce garments or other desired articles. Alternatively, the composite
35 base web 22 can be operably delivered directly into subsequent stages of a manufacturing line along a connecting path A.

- With reference to Fig. 2, the composite base web 22 can be operably delivered into a second separating means, such as a die cutting system 94 or the like, to longitudinally divide the composite web into a pair of composite fastener web sections 73a and 73b.
- 5 The cutter can produce a cooperating pair of periodic, substantially regularly undulating, serpentine division lines 62 and 62a which do not intersect and are positioned along an appointed medial section 36 of the composite base web 22. Each serpentine line extends generally along the machine-direction, longitudinal length dimension of the composite web 22 and includes alternately traversing, side-to-side sections thereof. The
- 10 traversing sections of the division line can optionally include retroceding portions thereof to provide for distinctively shaped fastening tabs 112. The division lines 62 and 62a separate apart appointed layers of the composite web 22 to provide the serpentine strip 80.
- 15 Each division line includes alternating portions occurring along the longitudinal direction 86 which, in the shown configurations, section both the web of hook material 24 and the carrier web material 34. In addition, each serpentine line can include alternating portions occurring along the longitudinal direction, which can be selectively arranged to extend into a one of the web sections of panel material 74 and 76. More particularly, the
- 20 serpentine line 62 can have substantially regularly occurring hill regions 114, and substantially regularly occurring valley regions 115 which alternate in occurrence with respect to the hill regions along the longitudinal direction 86. The hill regions 114 extend inboard to the medial region 28 of the composite web 22. The valley regions extend relatively outboard from the hill regions 114 and toward the outboard side edge region 60
- 25 of the first panel web section 74 which is most closely adjacent to the valley regions 115. With reference to Fig. 3, serpentine line 62 is to the left of serpentine line 62a. Accordingly, the valley regions 115 of the serpentine line 62 extend toward the left-position, first panel web section 74.
- 30 Similarly, the serpentine line 62a can have substantially regularly occurring hill regions 114a, and substantially regularly occurring valley regions 115a which alternate in occurrence with respect to the hill regions along the longitudinal direction 86. The hill regions 114a extend inboard to the medial region 28 of the composite web 22. The valley regions extend relatively outboard from the hill regions 114a and toward the
- 35 outboard side edge region 60 of the second panel web section 76 which is most closely adjacent to the valley regions 115a. Accordingly, the valley regions 115a of the

serpentine line 62a extend toward the right-position, second panel web section 76. In addition, the cooperating serpentine lines are arranged with the hill regions 114 of the serpentine line 62 positioned in a laterally opposed alignment with the valley regions 115a of the serpentine line 62a along the cross-direction 88. Similarly, the valley regions 5 115 of the serpentine line 62 positioned in a laterally opposed alignment with the hill regions 114a of the serpentine line 62a. Desirably, the hill regions 114 and 114a of the first and second serpentine division lines 62 and 62a, respectively, do not extend into their associated web sections of panel material 74 and 76, respectively. Desirably, the hill regions 114 and 114a also do not extend into their oppositely positioned web sections 10 of panel material 76 and 74, respectively. Each of the valley regions 115 and 115a of the serpentine lines, however, can be constructed and arranged to extend into their associated web sections of panel material 74 and 76, respectively, which is most closely positioned to the particular valley region.

15 Accordingly, the cooperating division lines 62 and 62a can operatively generate a substantially continuous, serpentine strip 80 having substantially regularly repeating, periodic edge contours. The strip 80 can then be readily removed away from the composite web. In the shown arrangements, a transporting system, such as a system including a guide roller 132 and/or a conventional vacuum duct system 134, operably 20 directs the serpentine strip 80 away from the composite web 22 and away from the fastener web sections 73a and 73b.

Additional details regarding the construction of suitable fastening tabs and fastening systems are, for example, described in the previously mentioned U.S. Patent Application 25 Serial No. 168,615 of T. Roessler et al., entitled DYNAMIC FITTING DIAPER, filed December 16, 1993 (attorney docket No. 10,961); and U.S. Patent Application Serial No. 603/477 of A. Long et al., entitled MECHANICAL FASTENING SYSTEM WITH GRIP TAB, filed March 6, 1996 (attorney docket No. 12,563).

30 In the shown configuration of the invention, the composite fastener web sections 73a and 73b are operably directed to a system of conventional folding boards 70 to reposition the individual fastening tabs 112 into a storage position against an appointed surface of its associated fastener web section 73a or 73b, as desired. Alternatively, the folding operation may be by-passed or omitted, and the tabs may remain unfolded.

35

A phase adjusting means, such as provided by alignment turn bars 116 and 118, operably everts the fastener web sections 73a and 73b, and repositions the lengthwise, machine-directional phasing of the fastener tabs on first fastener web section 73a relative to the fastener tabs on second fastener web section 73b. In the everting
5 operation, the fastener web sections 73a and 73b are laterally flipped and reversed such that the fastening tabs 112 are shifted from being located along the inboard edge regions of the fastener webs, and are moved to become located along the outboard edge regions of the fastener webs. The additional repositioning, phasing operation is configured to operably arrange appointed, corresponding pairs of fastening tabs 112 into a substantial
10 cross-deckle alignment along the cross-direction of the process and apparatus. Accordingly, the process and apparatus provide at least one corresponding, laterally opposed pair of fasteners, which includes a first fastener tab from the first composite fastener web section 73a and a second fastener tab from the second composite fastener web 73b. In the illustrated embodiment, the process is advantageously constructed to
15 provide a serial multiplicity of corresponding, laterally opposed pairs of the first and second fasteners.

The substantially aligned first and second fastener web sections 73a and 73b can be prepared for further attachment to other components of the desired article. In the
20 illustrated configuration, for example, the composite fastener web sections 73a and 73b are directed to an applicator 120 which deposits a suitable adhesive onto the regions of the composite fastener web sections that are appointed for further attachment. Other attaching mechanisms, such as thermal bonds, sonic bonds and the like may also be employed to supplement or replace the described adhesive attachment.

25

In further aspects of the method and apparatus of the invention, the first and second fastener web sections 73a and 73b are directed to a suitable third separating mechanism, such as a system of rotary cutters 96, for partitioning along the cross-direction of each of the fastener web sections to form a plurality of individual fastener
30 components 66. The individual fastener systems are directed to a suitable construction assembling mechanism, such as a system of assembly rollers, which can be configured to attach individual fastener systems onto a major body-facing side or outward-facing side of an article web 68, as desired.

35 For example, a phased, cut-and-place, intermittent assembling means, such as a mechanism comprising a system of conventional vacuum slip rolls 110 and rotary knife

and anvil systems 96, can be employed to connect opposed, cross-directionally aligned pairs of the fastener components 66 to laterally opposite side regions 98 of the article web 68. In the illustrated embodiment, for example, the cut-and-place assembling mechanism is constructed and arranged to operably connect a sequential plurality of the
5 paired fastener components 66 to the article web at a plurality of predetermined, spaced-apart locations along the machine-direction of the article web 68. An example of a suitable arrangement of rotary cutter and vacuum slip roll is described in U.S. Patent 4,795,510 issued January 3, 1989 to M. Wittrock et al. and entitled "PROCESS FOR APPLYING REINFORCING MATERIAL TO A DIAPER COVER MATERIAL" (attorney
10 docket No. 8366), the disclosure of which is hereby incorporated by reference in a manner that is consistent herewith.

The assembly mechanism operatively affixes the individual fastener components 66 to the opposed sides 98 of the article web 68, and opposed pairs of the individual fastener
15 components 66 are substantially aligned along the cross-direction 88 of the article web 68. In addition, ultrasonic bonders 126 may be employed to provide additional securement between the fastener components 66 and the article web 68. The article web can then be further processed and separated into a plurality of individual articles by conventional separating means.

20

In particular, the resultant article web 68 can be constructed to define an interconnected plurality of individual article segments 122, and a conventional cutting mechanism (not shown) can then separate the article web 68 along preselected division lines 100 to produce selected individual articles. The separating step can be performed by employing
25 any conventional cutting mechanism, such as a rotary cutter or the like.

The invention can further include mechanisms for providing a web of backsheet material, and for positioning at least one absorbent body at a selected location along a machine directional length of the backsheet web. A plurality of absorbent bodies can, for
30 example, be positioned at predetermined, regularly spaced locations along the length of the backsheet web. Another mechanism can then deliver a web of topsheet material to sandwich the absorbent body between the web of backsheet material and the web of topsheet material.

35 Other aspects of the invention can include a mechanism for attaching at least a pair of lengthwise extending elasticized containment flaps to the bodyside surface of the

topsheet web. Suitable containment flap configurations are described in detail in U.S. Patent 4,704,116 issued November 11, 1987 to K. Enloe and entitled DIAPERS WITH ELASTICIZED SIDE POCKET, the disclosure of which is hereby incorporated by reference in a manner that is consistent herewith. Other containment flap configurations
5 are described in U.S. Patent Application Serial No. 206,816 of R. Everett et al., entitled ABSORBENT ARTICLE HAVING AN IMPROVED SURGE MANAGEMENT and filed March 4, 1994 (attorney docket No. 11,375), the disclosure of which is hereby incorporated by reference in a manner that is consistent herewith.

10 With reference to Figs. 5, 6 and 7, another aspect of the invention can provide a system for producing a set of multiple composite webs 22. The shown method and apparatus for forming fastener components, is configured to provide first and second substantially continuous webs of a first mechanical fastening component, such as webs of hook
15 material 24a and 24b, to provide primary fastening sections of the composite webs. Each of the first mechanical fastening components includes a base layer, such as hook base layer 26, which has a first and second, laterally opposed, longitudinally extending side sections, such as side edge regions, such as side sections 30 and 32a or side sections
20 30a and 32, of the web of the first mechanical fastening component. Each of the side sections has a plurality of first mechanical fastening elements, such the shown hook elements 54, which are integrally formed with said base layer and extend away from a base plane of the hook base layer. The first mechanical fastening elements are configured to operably engage a selected, cooperating second mechanical fastening
25 component, such as a conventional loop material. At least one, substantially continuous web of carrier material, such as a carrier web 34a or 34b, can be attached to each of said first and second webs of the first mechanical fastening component. Each of the at least
30 one web of carrier material provides for an extending section of carrier web material, such as carrier side section 38 or 40, which extends laterally away from each of the side sections of each of said first and second webs of said first mechanical fastening component. In addition, each of the at least one web of carrier material provides an appointed first carrier side edge region, such as a side edge portion 39 of carrier side
35 section 38, and an appointed second carrier side edge region, such as a side edge portion 41 of carrier side section 40. A substantially continuous, relatively central web of panel material, such as panel web 75, is attached to the second side edge portion 41 of each of the at least one web of carrier material, and a relatively outboard web of panel
material, such as provided by panel web 74 or 76, is attached to extend laterally
outboard from the first side edge portion 39 of each of the at least one web of carrier

material, thereby forming a composite fastener web assembly 27.

In particular aspects, the technique of the invention can further include a dividing of the relatively central web 75 of panel material to provide first and second composite fastener
5 webs, such as composite webs 72a and 72b. In other aspects, the technique of the invention can include a dividing of at least the web of the first mechanical fastening component, such as web 24a and/or 24b, along a cooperating pair of serpentine division lines composed of a first serpentine division line 62 and a second serpentine division line 62a, which are non-intersecting with each other and extend generally longitudinally along
10 the web of the first mechanical fastening component, as presented previously in present description.

The representatively shown configuration includes a supplying means, such as supply roll 57, which provides a first, panel web 56 composed of the selected panel material.
15 The panel material may be substantially nonelastomeric or may be elastomeric, as previously described.

A suitable separating mechanism, such as a system of slitters 52 or other cutters, is employed to divide the panel web 56 into a plurality of sections. For example, the panel
20 web 56 can be separated into the first panel web section 74, the second panel web section 76, and at least a third panel web section 75. In the illustrated configuration, for example, slit 52 can partition the panel web 56 into three sections, wherein the first and second sections have substantially equal cross-directional widths, and the third section 75 has a cross-directional width which is approximately twice as large as that of
25 the first and second sections. Optionally, any or all of the separated web sections 74, 75 and 76 can have relatively equal or unequal cross-directional widths, as desired. Each of the panel web sections 74 and 76 has an inboard side edge region 58 and an outboard side edge region 60. The third, relatively middle web section 75 has first and second side edge regions 77 and 79, respectively.

30

The relative lateral positionings of the first, second and third web sections 74, 75 and 76, respectively, are desirably adjusted to a desired spacing along the cross-deckle direction 88 of the process by an operable directing means, such as provided by the spreader mechanism 78. In the illustrated embodiment, for example, the spreader
35 mechanism can include a conventional guiding system which repositions and relocates each of the first and second webs of side panel material at a desired spacing away from

the third web 75 of side panel material. For example, the spreader 78 can include any of the conventional spreader mechanisms described herein. After the spreader mechanism has generated the desired lateral, cross-directional spacings of the first and second panel web sections away from the relatively centrally located, third panel web section 75, the three panel web sections are directed to a second assembling means, such as provided by the system of assembly rollers 50.

With reference to Figs. 5 and 6, a second supplying means, such as supply roll 23, supplies a web of the selected, first mechanical fastening component, such as the illustrated web 25 of hook material. The hook material web includes a base layer 26, and defines a first side section 30, a second side section 32, and a generally central section 31. As previously mentioned, the base layer 26 has a first surface 46 and an oppositely located second surface 48. The first surface 46 is typically appointed to be inwardly facing of the associated article, and includes a plurality of fastening elements projecting and extending therefrom. The shown arrangement of the supply roll 23 has the hook elements extending radially outwardly from the supply roll. In particular aspects of the invention, the fastening elements are integrally formed with the base layer 26 and can be composed of substantially the same material as the base layer. Desired configurations include hook elements which are coextruded or otherwise integrally formed from the base layer material.

The shown configuration of the invention delivers the hook material web 25 to a suitable dividing mechanism, such as the shown slitter 102, which separates the web 25 into a set of two discrete webs 24a and 24b. The shown slitter cuts along a longitudinal centerline of the central section 31 of the hook material web to provide sections 30a and 32a, as desired for the intended configurations of the webs 24a and 24b. Alternatively, the central section 31 of the web 25 may include a constructed line of weakness which extends longitudinally along the web. The line of weakness is constructed to allow the web 25 to be selectively and reliably fractured or torn along an appointed separation line 33. The shown webs 24a and 24b are substantially identical to each other. Optionally, however, the slitter can be configured and arranged to provide webs 24a and 24b which differ from each other. After the dividing operation, the web set composed of webs 24a and 24b are directed through a conventional spreader mechanism 106 which operatively positions the webs in a desired, laterally spaced-apart configuration, as appropriate for subsequent processing operations.

At least one carrier web 34 is delivered from a suitable source, such as supply roll 35. In the shown arrangement, the carrier web 34 is divided into a set of two carrier webs 34a and 34b by a slitter 128 or other suitable separating mechanism, and the carrier webs are positioned in a desired, laterally spaced-apart relationship by a suitable spreader
5 device 130. Optionally, the set of carrier webs can be delivered from separate supply rolls. As representatively shown, each of the carrier webs 34a and 34b has a first major facing surface 42 and a second major facing surface 44. Each carrier web also provides for a first side section 38 and a second side section 40. The second surface 48 of the web 24a of hook material is operably bonded and laminated to the medial portion 36 of
10 the first surface 42 of carrier web to 34a provide a first composite fastener web 72a, and the surface 48 of the web 24b of hook material is operably bonded and laminated to the medial portion 36 of the first surface 42 of carrier web to 34b provide a second composite fastener web 72b. An operative attaching mechanism, such as the shown adhesive applicator 82, generates an attachment for operably affixing each of the hook
15 material webs 24a and 24b to its associated carrier web 34a and 34b. Desirably, each hook material web is substantially centered along the cross-direction of its corresponding carrier web 34. The resultant assemblies provides a set of two composite web laminates in which the hook elements 54 are in a generally exposed position. The assembled composite fastener webs 72a and 72b can then be operably directed and transported for
20 further processing.

In the representatively shown configuration of the invention, suitable directing means, such as the shown system of guiding rollers 84 and 50, transport the fastener webs 72a and 72b to positions which are operatively interposed between the panel web sections
25 74, 75 and 76. In particular, fastener web 72a is located to extend and span between panel web sections 74 and 75, and fastener web 72b is located to extend and span between panel web sections 75 and 76. A suitable attaching mechanism, such as the shown system of adhesive applicator 90 and ultrasonic bonder 92, generates an attachment for affixing each of the composite fastener webs 72a and 72b in between its
30 corresponding pair of laterally spaced-apart, panel web sections 74-75 and 76-75, respectively, to provide the composite fastener web assembly 27. More particularly, the adhesive applicator initially attaches the side edges of each of the composite webs 72a and 72b to corresponding, overlapping edges of its associated pair of panel web sections 74-75 and 76-75, respectively. The inboard edge region 58 of the first panel
35 web section 74 attaches to the overlapping first side edge region 38 of the carrier web 34a, and the second side edge region 40 of the carrier web 34a attaches to the first,

- overlapping side edge region 77 of panel web 75. Similarly, the inboard edge region 58 of the second panel web section 76 attaches to the overlapping first side edge region 38 of the carrier web 34b, and the second side edge region 40 of the carrier web 34b attaches to the second, overlapping side edge region 79 of panel web 75. The sonic
5 bonder 92 supplements the initial attachments with ultrasonic, thermal bonds. The sonic bonder can also be configured to generate an attachment between the hook materials 24a and 24b and the carrier webs 34a and 34b, which together have provided the composite webs 72a and 72b, respectively.
- 10 The composite web assembly 27 can then be moved or otherwise directed for further processing. For example, the composite web assembly 27 can be directed to another dividing mechanism, such as provided for by slit 108, to separate the web assembly 27 into a set of two composite webs 22a and 22b. Each of the composite webs 22a and 22b may be wound onto rolls 124 or otherwise configured for transport to another,
15 remotely located manufacturing line which is employed to produce garments or other desired articles. Alternatively, either or both of the composite base webs 22a and 22b can be operably delivered directly into subsequent stages of an associated manufacturing line (e.g. Fig. 2) along an individual connecting path A.
- 20 Having described the invention in rather full detail, it will be readily apparent that various changes and modifications can be made without departing from the spirit of the invention. All of such changes and modifications are contemplated as being within the scope of the invention as defined by the subjoined claims.

We claim:

1. A method for forming fastener components, comprising:
providing a composite web which has a longitudinal dimension and a lateral
5 dimension and includes a web of a first mechanical fastening component, said first
mechanical fastening component web including a base layer which has first and second
longitudinally extending side sections and has a plurality of first mechanical fastening
elements which are integrally formed with said base layer and extend away from a base
plane of said base layer, said first mechanical fastening elements configured to operably
10 engage a selected, cooperating second mechanical fastening component, said first
mechanical fastening component web having an extending section of carrier web
material attached to extend laterally outboard from each of said side sections of said first
mechanical fastening component web, and each section of carrier web material including
a web of panel material attached to extend laterally outboard from said each section of
15 carrier web material;
dividing said composite web along at least first and second, non-intersecting,
serpentine division lines which repeatedly traverse across a complete lateral width of said
first mechanical fastening component web and extend generally longitudinally along a
medial region of said composite web to provide for a serpentine strip, said first serpentine
20 division line having a first plurality of laterally inboard hill regions and relatively outboard
valley regions which alternate in occurrence along said longitudinal dimension of said
composite web, said second serpentine division line having a second plurality of laterally
inboard hill regions and relatively outboard valley regions which alternate in occurrence
along said longitudinal dimension of said composite web, and wherein said hill regions of
25 said first and second serpentine division lines do not extend into said webs of panel
material; and
removing said serpentine strip away from said composite web.
2. A method as recited in claim 1, wherein said valley regions of said first and
30 second serpentine division lines extend into said webs of panel material.
3. A method as recited in claim 1 further comprising a selective segmenting of said
composite web to provide for said plurality of fastener components.

4. A method as recited in claim 1, wherein each of said webs of panel material is elastomerically extensible along said lateral dimension.
5. A method as recited in claim 1, wherein method includes
5 providing a composite web which includes a web of hook material, said hook material web including a hook base layer which has first and second longitudinally extending side sections and has a plurality of hook elements which are integrally formed with said base layer and extend away from a base plane of said hook base layer, said hook elements configured to operably engage a selected, cooperating loop material, said
10 web of hook material having an extending section of carrier web material attached to extend laterally outboard from each of said side sections of said web of hook material, and each section of carrier web material including a web of panel material attached to extend laterally outboard from said each section of carrier web material;
dividing said composite web along at least first and second, non-intersecting,
15 serpentine division lines which repeatedly traverse across a complete lateral width of said web of hook material and extend generally longitudinally along a medial region of said composite web to provide for a serpentine strip, said first serpentine division line having a first plurality of laterally inboard hill regions and relatively outboard valley regions which alternate in occurrence along said longitudinal dimension of said composite web, said
20 second serpentine division line having a second plurality of laterally inboard hill regions and relatively outboard valley regions which alternate in occurrence along said longitudinal dimension of said composite web, and wherein said hill regions of said first and second serpentine division lines do not extend into said webs of panel material; and
removing said serpentine strip away from said composite web.
25
6. A method as recited in claim 5, wherein said valley regions of said first and second serpentine division lines extend into said webs of panel material.
7. A method as recited in claim 1, wherein said method is arranged to provide a
30 composite web having an extending panel web of elastomerically stretchable panel material attached to extend laterally outboard from each section of carrier web material.
8. A method as recited in claim 1, further comprising an attaching of said fastener components to appointed side regions of an article web.
35

9. A method as recited in claim 8, further comprising a sectioning of said article web into a plurality of individual articles.
10. A method as recited in claim 1, wherein said method provides said serpentine division line in a configuration which substantially avoids extending into said side sections of said web of said first mechanical fastening component.
11. A method for forming a plurality of fastener components, comprising:
providing a substantially continuous web of a first mechanical fastening component, said first mechanical fastening component including a base layer which has first and second longitudinally extending side sections and has a plurality of first mechanical fastening elements which are integrally formed with said base layer and extend away from a base plane of said hook base layer, said first mechanical fastening elements configured to operably engage a selected, cooperating second mechanical fastening component;
- attaching at least one, substantially continuous web of carrier material to said web of said first mechanical fastening component to provide for an extending section of carrier web material which extends laterally outboard from each of said side sections of said web of said first mechanical fastening component;
- attaching a substantially continuous web of panel material to extend laterally outboard from said each extending section of carrier web material, thereby forming a composite fastener web;
- dividing said composite web along at least first and second, non-intersecting, serpentine division lines which repeatedly traverse across a complete lateral width of said first mechanical fastening component web and extend generally longitudinally along a medial region of said composite web to provide for a serpentine strip, said first serpentine division line having a first plurality of laterally inboard hill regions and relatively outboard valley regions which alternate in occurrence along said longitudinal dimension of said composite web, said second serpentine division line having a second plurality of laterally inboard hill regions and relatively outboard valley regions which alternate in occurrence along said longitudinal dimension of said composite web, and wherein said hill regions of said first and second serpentine division lines do not extend into said webs of panel material; and
- removing said serpentine strip away from said composite web.

12. A method as recited in claim 11, wherein said method includes providing a substantially continuous web of hook material, said hook material including a hook base layer which has a longitudinally extending medial section located between first and second, laterally opposed, longitudinally extending side sections of said web of hook material, each of said side sections having a plurality of hook elements which are integrally formed with said base layer and extend away from a base plane of said hook base layer, said hook elements configured to operably engage a selected, cooperating loop material, said medial section having a relatively lower density of said hook elements per unit area, as compared to said side sections,
- 5
- 10 attaching at least one, substantially continuous web of carrier material to said web of hook material to provide for an extending section of carrier web material which extends laterally outboard from each of said side sections of said web of hook material;
- 15 attaching a substantially continuous web of panel material to extend laterally outboard from said each extending section of carrier web material, thereby forming a composite fastener web;
- 20 dividing said composite web along at least first and second, non-intersecting, serpentine division lines which repeatedly traverse across a complete lateral width of said web of hook material and extend generally longitudinally along a medial region of said composite web to provide for a serpentine strip, said first serpentine division line having a first plurality of laterally inboard hill regions and relatively outboard valley regions which alternate in occurrence along said longitudinal dimension of said composite web, said second serpentine division line having a second plurality of laterally inboard hill regions and relatively outboard valley regions which alternate in occurrence along said longitudinal dimension of said composite web, and wherein said hill regions of said first and second serpentine division lines do not extend into said webs of panel material; and
- 25 removing away said serpentine strip away from said composite web.
13. A method as recited in claim 11, wherein said method is arranged to attach a substantially continuous web of elastomerically stretchable panel material to extend laterally outboard from said each extending section of carrier web material, thereby forming said composite fastener web.
- 30
14. A method as recited in claim 11, wherein said method is configured to provide first and second substantially continuous webs of carrier material which are operably attached to thereby provide said sections of carrier web material which extend laterally
- 35

outboard from each of said side sections of said web of hook material.

15. A method as recited in claim 11, wherein said valley regions of said first and second serpentine division lines extend into said webs of panel material.

5

16. A method as recited in claim 11, further including a partitioning of said composite web to provide for a plurality of fastener components; and an attaching of said fastener components to appointed side regions of an article web.

10 17. A method as recited in claim 16, further comprising a sectioning of said article web into a plurality of individual articles.

18. A method for forming fastener components, comprising:

15 providing first and second substantially continuous webs of a first mechanical fastening component, said first mechanical fastening component including a base layer which has first and second, laterally opposed, longitudinally extending side sections and has a plurality of first mechanical fastening elements which are integrally formed with said base layer and extend away from a base plane of said hook base layer, said first mechanical fastening elements configured to operably engage a selected, cooperating
20 second mechanical fastening component, said medial section having a relatively lower density of said first mechanical fastening elements per unit area, as compared to said side sections,

25 attaching at least one, substantially continuous web of carrier material to each of said first and second webs of said first mechanical fastening component, each of said at least one web of carrier material providing for an extending section of carrier web material which extends laterally away from each of said side sections of each of said first and second webs of said first mechanical fastening component, and each of said at least one web of carrier material providing an appointed first carrier side edge region and an appointed second carrier side edge region;

30 attaching a substantially continuous, relatively central web of panel material to said second side edge portion of each of said at least one web of carrier material; and

attaching a relatively outboard web of panel material to extend laterally outboard from said first side edge portion of each of said at least one web of carrier material, thereby forming a composite fastener web assembly.

19. A method as recited in claim 18 further including a dividing of said relatively central web of panel material to provide first and second composite fastener webs.
20. A method as recited in claim 19 further including a dividing of at least one of said composite fastener webs along at least first and second, non-intersecting, serpentine division lines which repeatedly traverse across a complete lateral width of said first mechanical fastening component web and extend generally longitudinally along a medial region of said composite web to provide for a serpentine strip, said first serpentine division line having a first plurality of laterally inboard hill regions and relatively outboard valley regions which alternate in occurrence along said longitudinal dimension of said composite web, said second serpentine division line having a second plurality of laterally inboard hill regions and relatively outboard valley regions which alternate in occurrence along said longitudinal dimension of said composite web, and wherein said hill regions of said first and second serpentine division lines do not extend into said webs of panel material; and
- a removing of said serpentine strip away from said at least one composite fastener web.
21. A method as recited in claim 20, further comprising a segmenting of said at least one composite fastener web to form individual fastener components.

1/5

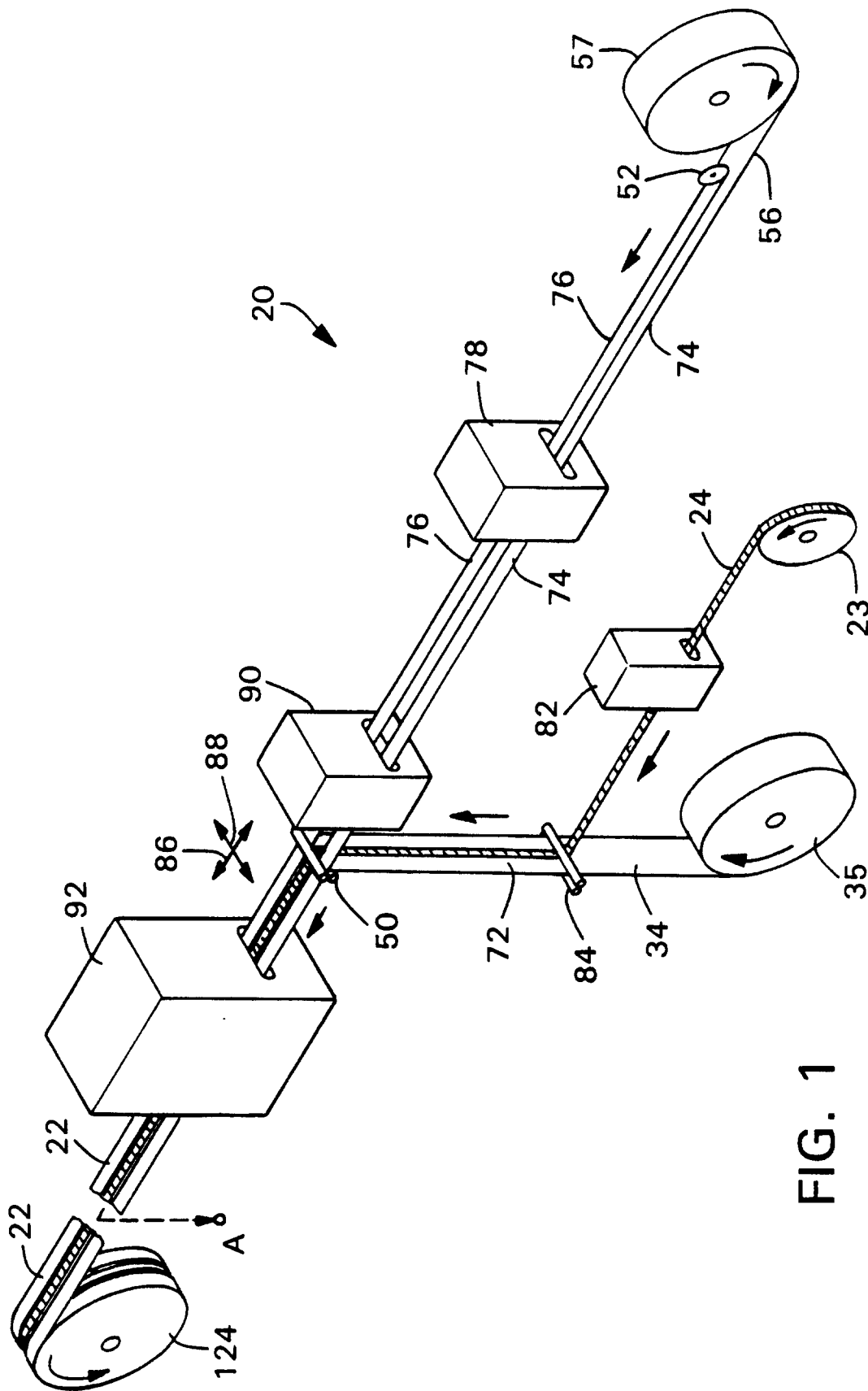

FIG. 1

3/5

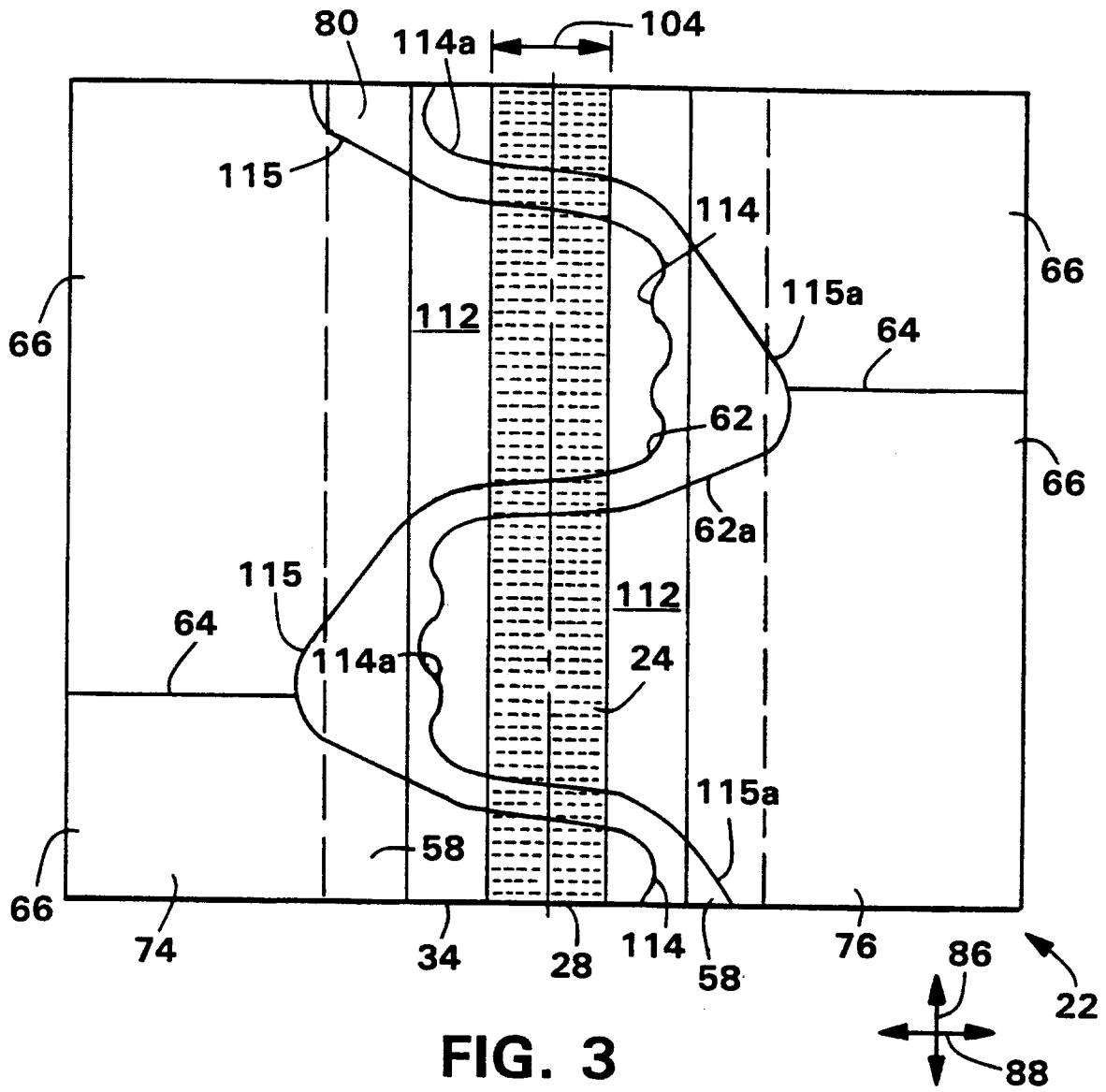

FIG. 3

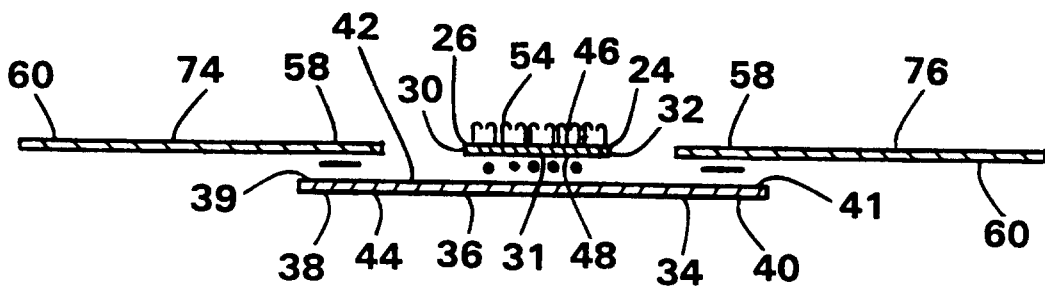

FIG. 4

4/5

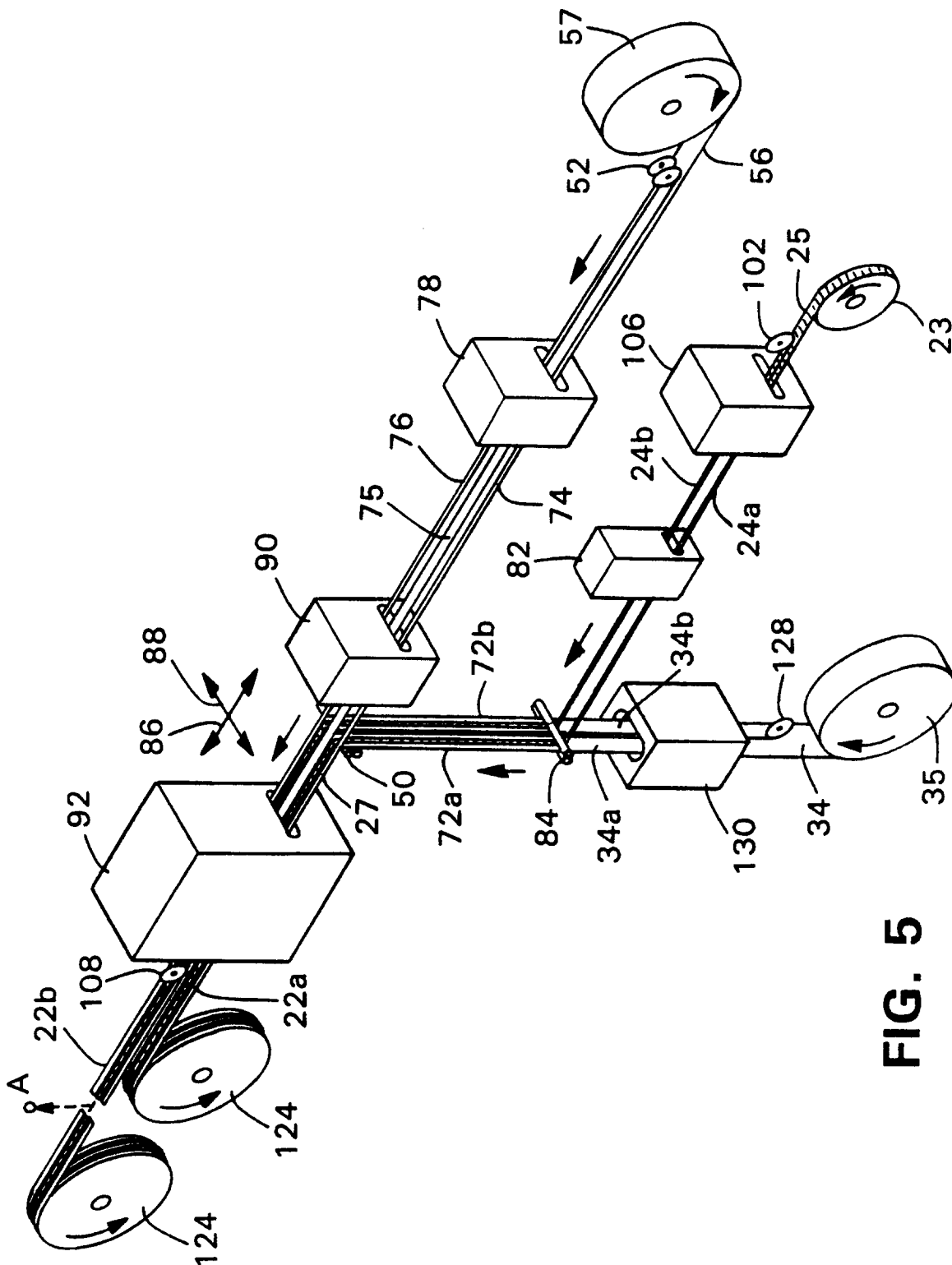

FIG. 5

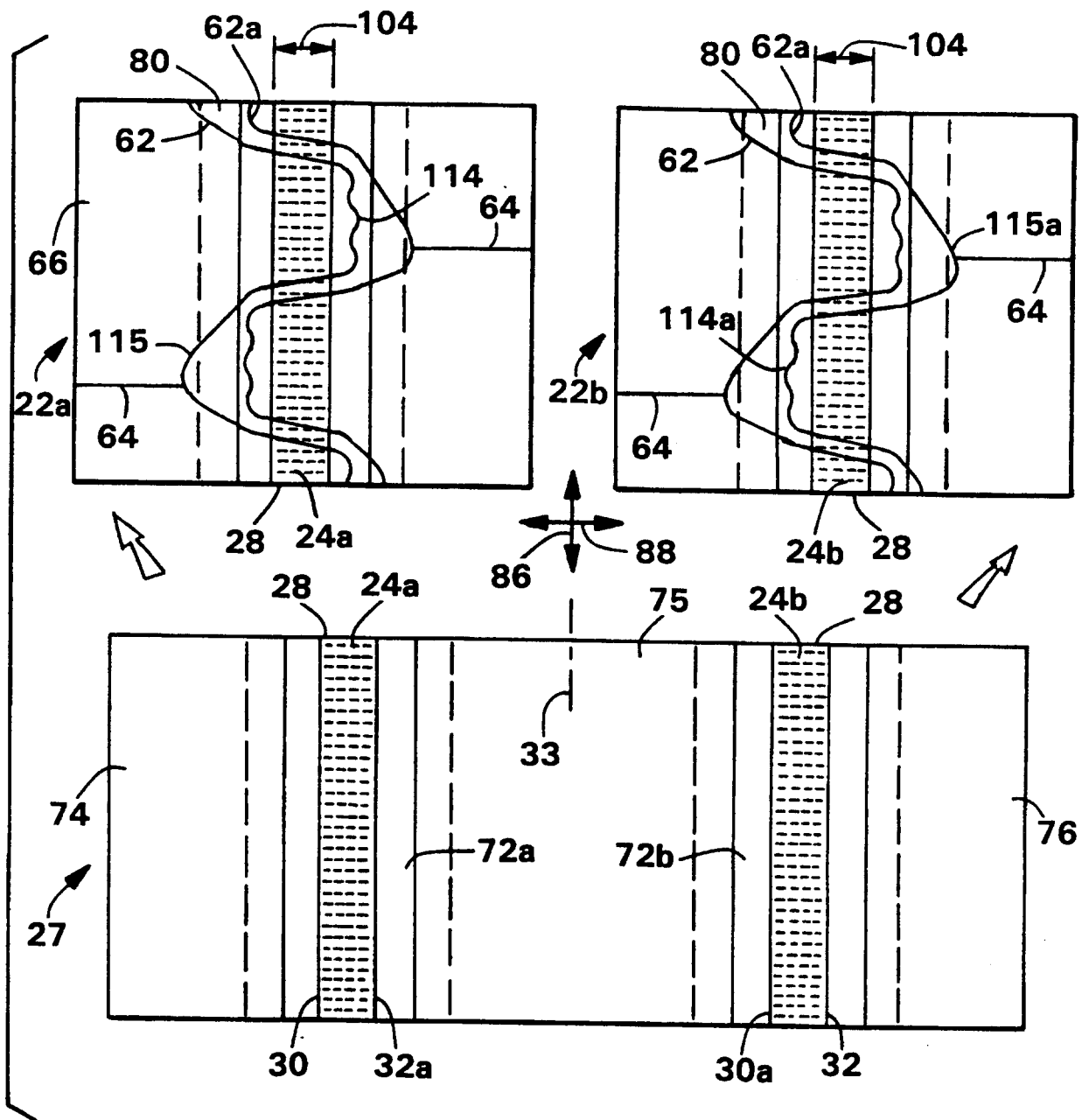

FIG. 6

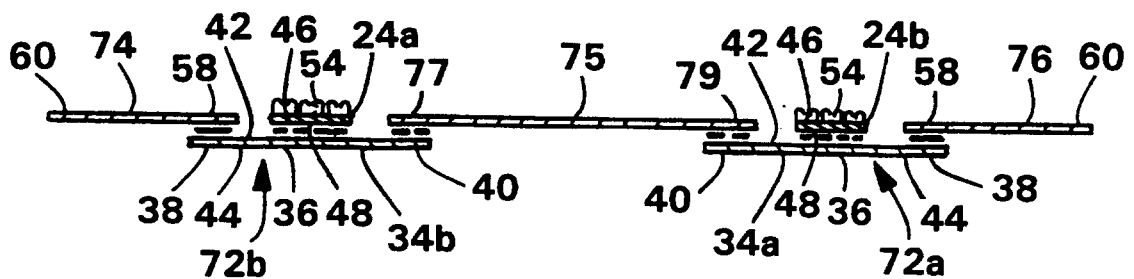

FIG. 7

