

P. PROVOST.
GRAIN DRIER.

APPLICATION FILED AUG. 18, 1905.

2 SHEETS—SHEET 1.

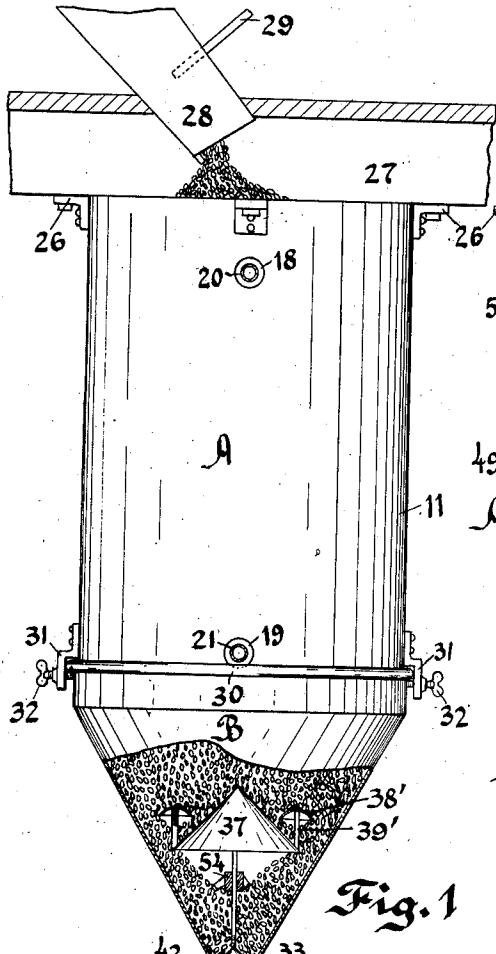

Fig. 1

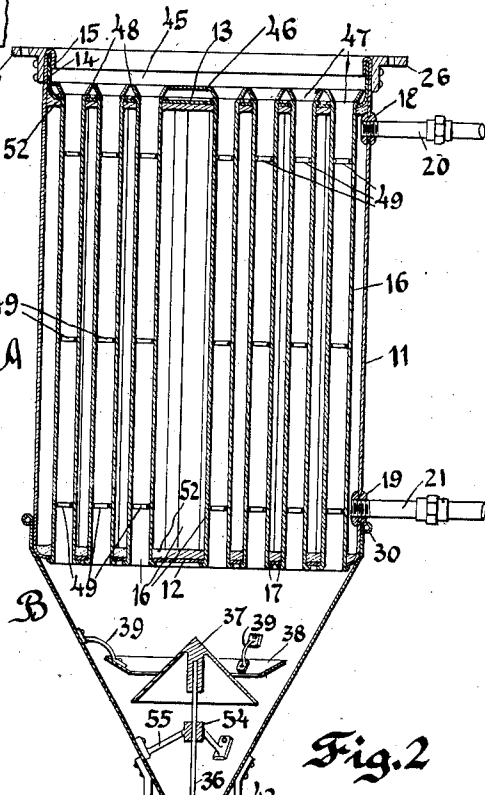

Fig. 2

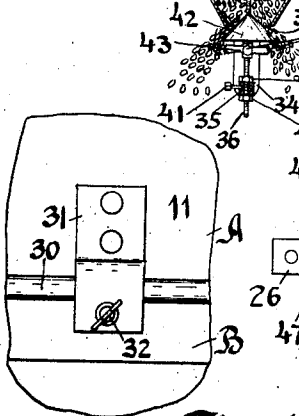

Fig. 6

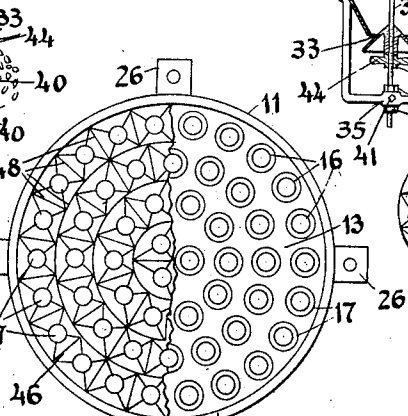

Fig. 3

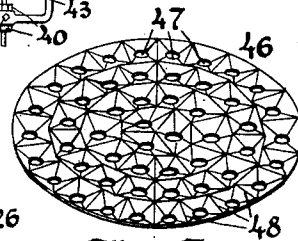

Fig. 5

Inventor

Witnesses
Jack Dougherty
Cecilia S. Bomb

Peter Provost

George W. Moore
Attorney

No. 893,812.

PATENTED JULY 21, 1908.

P. PROVOST.
GRAIN DRIER.

APPLICATION FILED AUG. 18, 1905.

2 SHEETS—SHEET 2.

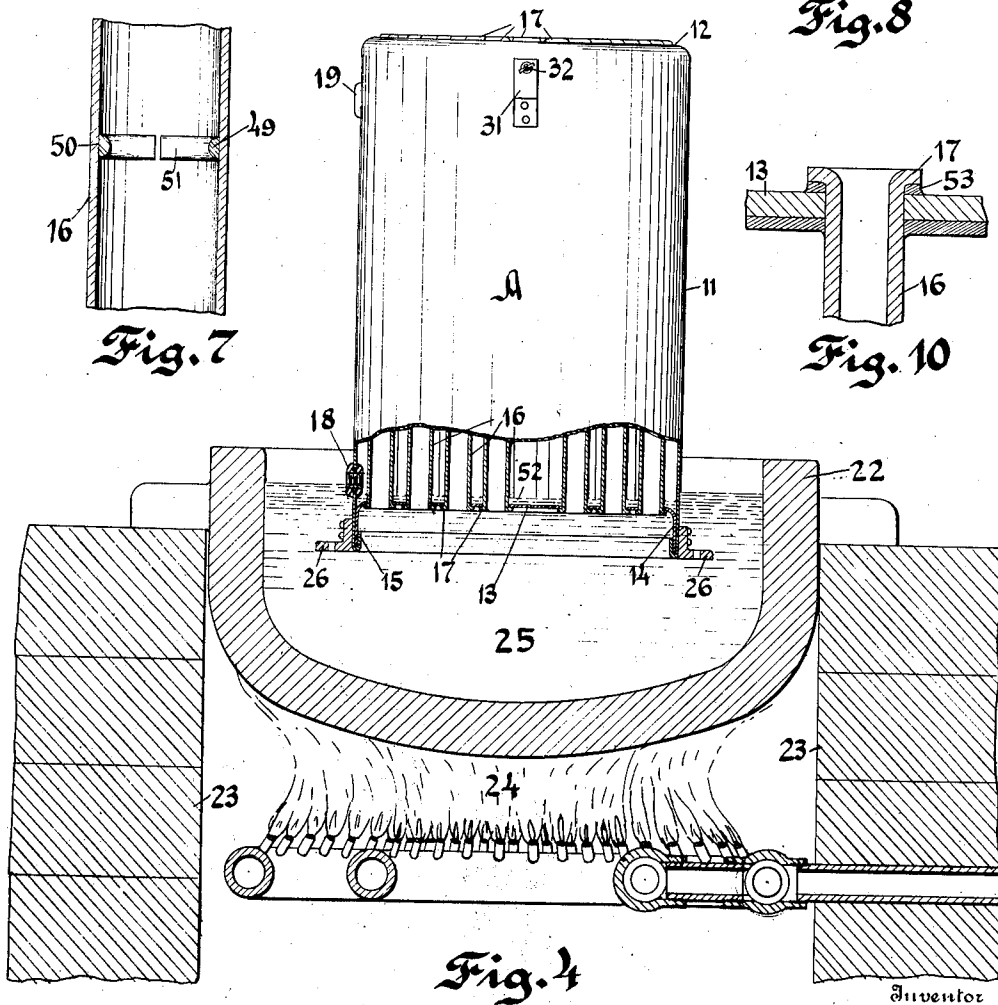
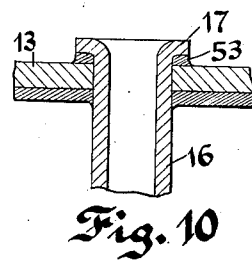
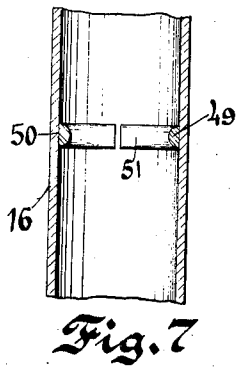
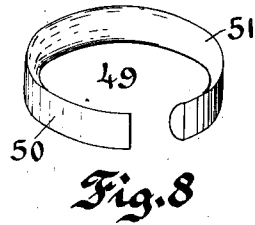
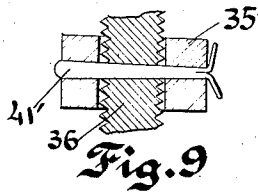

Witnesses

Jack Dougherty
Bertram H. Link

Peter Provost

George W. Moore
Attorney

UNITED STATES PATENT OFFICE.

PETER PROVOST, OF MENOMINEE, MICHIGAN, ASSIGNOR TO PROVOST MANUFACTURING COMPANY, A CORPORATION OF WISCONSIN.

GRAIN-DRIER.

No. 893,812.

Specification of Letters Patent.

Patented July 21, 1908.

Application filed August 18, 1905. Serial No. 274,684.

To all whom it may concern:

Be it known that I, PETER PROVOST, of Menominee, Michigan, have invented a Grain-Drier, of which the following is a specification.

This invention relates to a grain-drier of the type wherein the grain to be dried passes through a series of steam-heated pipes.

The object of my present invention is to improve this type of drier, first by an easier, simpler and better construction of the heating-tank for the tubes; second, by providing improved means for regulating the flow of grain through the tubes whereby it is distributed uniformly, and prevent it from passing faster through some tubes than others; third, by providing independent means for regulating the flow of grain through the apparatus as a whole; fourth, by providing means for preventing the grain from lodging on the upper surface of the heating-tank whereby they become overheated and baked; fifth, by providing a movable lower portion and means for attaching it to the heating-tank; and sixth, by providing novel means for choking the tubes through which the grain passes, which present superior advantages to the means heretofore employed.

My invention comprises the process of constructing my invention, and such special features of construction as will be hereinafter specifically described and pointed out in the claims.

My invention may best be understood from a consideration of the following description, reference being had to the accompanying drawings, in which

Figure 1 is a side elevation of my drier as mounted for use, the discharge cone at the lower end thereof being shown in section. Fig. 2 is a longitudinal section through the apparatus in a plane at right angles to that of Fig. 1. In this figure the regulator has a slightly different form from that of Fig. 1. Fig. 3 is a plan view of the apparatus, the funnel-plate being half broken away, Fig. 4 is a side elevation of a drier-tank in process of immersion according to my invention, Fig. 5 is a perspective view of the funnel-plate, Fig. 6 is a front elevation of one of the clamping-ears, Fig. 7 is a longitudinal section on an enlarged scale through one of the tubes showing a choke-ring in position therein, Fig. 8 is a perspective view of a choke ring, Fig. 9 is a section on an enlarged scale

through the stirrup supporting the regulating cone showing one way of permanently securing the latter. Fig. 10 is a longitudinal section on an enlarged scale on one end of a drier-tube to show the method of sealing the joint between it and the tank-head.

In these drawings each reference character refers always to the same part.

My improved heater consists of two principal parts, to wit, a heating-tank A and a discharge-cone B, which are fitted together in the manner shown in the drawing. The heating-tank in my present invention is not formed in the manner formerly employed by bending a sheet into a cylinder, but consists of a sheet of metal drawn through dies into cup-shaped form and designated 11, so that it has no seams or rivets which leak or interfere with the connection of the discharge-cone thereto. As so formed the sheet 11 has a continuous and integral bottom-portion 12 and its top-portion 13 is formed in a similar manner by pressing a sheet into a shallower cup-shaped form forming flanges 14 thereon, which fit closely inside the cylindrical portion of the body-piece 11, and when fitted therinto the upper edge of the latter is turned inwardly to form an overlap 15, which grips the edges of the top-piece 13 securely, and prevents it from coming out. Before putting together, the bottom 12 and top 13 are drilled or punched with a number of apertures to receive a plurality of tubes 16, whose ends pass through the bottom 12 and top 13 respectively, and are turned over or expanded as shown at 17. Two holes are bored in the sides of the cylindrical body-portion 11 near the top and bottom thereof, and lined with tubular rivets 18 and 19 to receive induct and educt pipes 20 and 21 for the heating fluid, which is generally but not necessarily steam.

I do not depend on the tightness of the joints or upon calking thereof to prevent leakage of steam. The absolute prevention of all leakage to the exterior of the tank is absolutely necessary to success, for the slightest leakage of steam would reduce the grain to a pulpy or partly digested condition and spoil it for flour-making purposes. To this end I put the heating-tank through a special process to tighten the joints as will now be explained.

In Fig. 4 is shown a melting-pot 22 sup-

110

ported on walls 23 inclosing a furnace 24 whereby a bath of metal 25, which may be either solder or preferably brass, tin or some other metal that will alloy directly with the metal of the tank, is kept in a melted condition. Unless the metal will alloy directly with that of the tank, it will be necessary to coat the tank first with an intermediary composition whereby the melted metal is caused to adhere thereto. Into this metal bath the tank A is immersed first at one end and then at the other until the melted metal runs through one of the orifices 18, 19 and covers the end of the tank to a slight depth, say one-eighth to one-quarter of an inch. It is clear that by so doing the metal will become heated up to the alloying temperature and that the joints and places for leakage in the tubes and members of the tank will be hermetically sealed, and further the layer of metal 52 on the bottom of the tank, which is then on removing the latter from the bath left to harden in a horizontal position, will add to the strength of the tank and particularly to the tightness of the joints.

I further prefer to secure the joints between the tube-ends and the tank-heads by a peculiar method of expanding the former, which is clearly illustrated in Fig. 10. The expanded portion 17 is turned over to form an annular flange substantially parallel with the head 12 or 13, but leaving a small crevice or space between the two so as to admit a ring 53 of the fused metal surrounding the tube on the outside, and additionally preventing any leakage of steam there-through. It will be understood that the annular crevice is sufficiently small to hold a metal-ring 53 in place by capillarity after the tank-head has been removed from the bath 25, and until the ring 53 has had time to harden.

When, as is at present customary, the tank is made of iron, and the tubes of copper, great difficulty has been found in practice in procuring and maintaining an absolute tightness of the joints, especially under high pressure of steam. The reason for this lies in the electrolysis and corrosion at the joints of the iron, which is brought about by the action of water of condensation collecting upon them, so that even when the joints are absolutely tight at the beginning, they soon cease to be so. By applying the blanket of solder over the entire surface, as heretofore described, these joints are protected completely from such electrolytic corrosion, in fact, from corrosion of any kind; and where, as is usual, the soldering alloy is electropositive to iron, it will also protect the entire tank against corrosion on well known principles.

The tank so formed is provided at its upper end with ears 26 whereby it is secured to

an overhead object, more particularly to the floor-beams 27 (Fig. 1) of the floor above, through which projects a duct 28, through which the grain flows from a receiving-bin above, and may be regulated by any suitable means such as a slide 29.

The discharge-cone B is preferably of conical sheet-metal having a roll 30 around its upper margin, which surrounds and closely incloses the lower end of the tank as shown, and downwardly projecting clamping-ears 31 are secured to the tank and have thumb-screws 32 projecting therethrough, which engage under the roll 30. While I do not limit myself necessarily to any number of clamping-ears, it is preferable in most situations to use but two as shown in Fig. 1, arranged at opposite sides of the tank, and to enable this to be done and still hold the discharge-cone B perfectly central, the latter is so constructed that when the roll 30 is in position to be clamped by the screws 32, the inner face of the conical portion abuts closely against the end of the tank, thus absolutely preventing any wobbling of the discharge-cone and causing it to be maintained strictly concentric with the tank. This novel construction is simpler than that previously used, and presents the advantage of enabling the ready removal of the discharge-cone from any of a series of driers mounted closely side by side, in which position three or more clamping-ears could not be conveniently manipulated.

The discharge-cone B is truncated at the lower end to form a discharge-orifice 33, below which is mounted a stirrup 34 secured to the sides of the cone and having in its center an apertured boss 35 supporting a screw-stem 36, which projects upward axially within the discharge-cone and has mounted on its upper end a regulating-cone 37. Above and surrounding the cone 37 is mounted a secondary regulating-ring 38 as shown in Fig. 2, and 38' as shown in Fig. 1. This regulating-ring may have either of the two mountings shown in Figs. 1 and 2, respectively, or it may be omitted altogether according to the size of the apparatus. The form of Fig. 2, in which the regulating-ring is in the form of a reversed cone supported by brackets 39 from the sides of the discharge-cone, is found best adapted to the larger sizes; the form 38' in Fig. 1, which is in the form of a double-pitched ring supported on posts 39' from the margin of the cone 37, is found best adapted to the intermediate sizes; while on the smallest sizes no regulating-ring is found necessary and it is omitted. The screw-stem 36 is adjusted in position by means of a pair of lock-nuts 40, which engage the threads of the stem on opposite sides of the boss 35, and when the height of the cone 37 has been properly adjusted it is fixed by means of a set-screw 41 binding the screw-stem from the

side. The stem 36 is braced by a tubular guide 54 within the cone B and supported from the latter by legs 55.

The devices just described are intended to regulate the flow of grain through the different tubes so that all tubes do the same amount of work and the grain does not fall faster in some tubes than in others, and this function is very successfully accomplished by it. Each apparatus is tested before leaving the factory and the regulating-cone 37 adjusted to proper position and then fixed permanently. It may be found preferable to remove the lock-nuts altogether and to replace the set-screw 41 by a split-pin 41', as shown by the enlarged view, Fig. 9.

To regulate the discharge from the cone B, I employ a conical plug 42 loosely mounted on the stem 36 and supported by a hand-nut 43 engaging the threads thereof and having handles 44 for turning the same. It is clear that by rotating the nut 43 the plug 42 will be raised and lowered and permit the grain to flow out at a greater or less rate, or will cut it off altogether.

It will be seen that when the grain is discharged into the upper end of the tank 11, it is received within the basin 45 of the top-piece 13. As the openings within the tubes 16 do not cover the entire bottom of this basin, places are left where grain might accumulate and become overheated or baked. To avoid this I introduce a novel funnel-plate 46, illustrated in perspective in Fig. 5, and shown in section and partial plan in Figs. 2 and 3 respectively. This plate consists of a piece of sheet-metal having holes 47 punched therein, corresponding to the openings of the tubes 16 and having the remaining portion drawn up into ridges 48 between the holes, so as to leave only sloping surfaces leading from the ridges to the holes, down which the grain slides and is carried through the holes 47. Whatever grains might remain for a short period on the ridges themselves are held out of contact with the steam-heated surface and thus are prevented from being overheated.

A special feature of my improved drier is the novel method of choking the tubes whereby grain is caused to flow more slowly through them. Heretofore this has been accomplished by working the metal of the tubes into a neck at regular intervals, and this had the disadvantages that it was difficult and rather expensive to perform, weakened the tubes, and made them less durable because the necks so formed would become worn out rapidly owing to the friction of the grain thereagainst, and then the tube had to be replaced. Moreover, these necks had a permanent spacing and could not be moved or increased in number as required by different circumstances. In my improved form no necks are formed in the tubes, nor are

they altered in any way, but I insert within them a number of choke-rings 49 made of spring-metal, one of which is shown in perspective in Fig. 8. Each choke-ring has preferably a flat cylindrical outer surface 50 resting against the inner side of the tube, and a curved or tortuous inner surface 51 which projects within the tube to the requisite extent and so chokes it. It is obvious that these choke-rings may be arranged in any number and spacing desired, may be of any size required, and when worn out by friction can be replaced without injury to the tube itself.

It will be readily understood that various modifications of my invention might be devised by those skilled in the art, and I therefore do not limit myself to the precise construction as shown, but reserve the right to the principles involved therein broadly as set forth in the claims.

Having thus described my invention, what I claim as new and desire to secure by Letters Patent is:

1. In a grain-drier, the combination of a tank having seamless and continuous bottom and sides, a closed top and a plurality of tubes arranged for the passage of grain therethrough, means for admitting a heating fluid to the interior of said tank, and a discharge-cone having regulating devices attached to the bottom of said tank.

2. In a grain-drier, the combination of a tank having seamless and continuous bottom and sides, a closed top, and a plurality of tubes arranged for the passage of grain therethrough, means for admitting a heating fluid to the interior of said tank, and a discharge-cone having a cylindrical upper end fitting around the base of said tank, said cone having regulating device therein.

3. In a grain-drier, the combination of a tank having seamless and continuous bottom and sides and a cover closing the open end thereof, a plurality of tubes arranged for the passage of grain therethrough connecting the top and bottom and opening on the exterior of said tank, a layer of fusible metal, covering the joints between said tubes, cover and tank, and means for admitting a heating fluid to the interior of said tank.

4. A drier-tank comprising an integral seamless and continuous body-piece comprising a cylindrical portion and a head, a cup-shaped integral head fitting in the open end thereof, said body-portion having its edges bent over and inclosing the edges of said head-piece, a plurality of longitudinal tubes fixed at their ends in the respective heads of said tank, and a layer of fusible metal alloying with the metal of said tank covering the joints on one of the heads thereof.

5. In a grain-drier, in combination with a discharge-cone having an opening at its lower end, an upright cone within said cone, means for raising and lowering said upright

cone, and a regulating-ring above and surrounding said upright cone.

6. In a grain drier, in combination with a discharge-element comprising an inverted cone having an opening at its lower end, a support below said open lower end, an upright screw-stem mounted on said support, an upright regulating-cone mounted on said screw-stem interiorly of said discharge-cone, and means engaging the thread of said screw-stem for vertically adjusting the same.

7. In a grain drier, in combination with a discharge-element comprising an inverted cone having an opening at its lower end, a support below said open lower end, an upright screw-stem mounted on said support, an upright regulating-cone mounted on said screw-stem interiorly of said discharge-cone, means engaging the thread of said screw-stem for vertically adjusting the same, a conical plug mounted on said screw-stem, and means engaging the thread of said screw-stem for regulating the height of said plug.

8. In a grain-drier, in combination with a discharge-element comprising an inverted cone having an opening at its lower end, a support below said open lower end, an upright screw-stem mounted on said support, a conical plug loosely mounted on said screw-stem below the orifice at the lower end of said discharge-cone and adapted to close the latter, and a hand-nut engaging the thread of said screw-stem and forming a support for said plug whereby the height of the latter is adjusted.

9. In a grain-drier, in combination with a discharge-element comprising an inverted cone having an opening at its lower end, a support below said open lower end, an upright screw-stem mounted on said support, an upright regulating-cone mounted on said screw-stem interiorly of said discharge-cone, means engaging the thread of said screw-stem for vertically adjusting the same, and a regulating-ring above and surrounding said regulating-cone.

10. In a grain-drier, a discharge-element comprising an inverted cone having an opening in its lower end, in combination with a stirrup depending from the sides of said cone below said opening and having a vertical aperture concentric therewith, a vertical screw-stem mounted in said aperture and vertically adjustable therein, means for vertically adjusting said stem, means for fixing said stem in position with respect to said stirrup, and a regulating-element mounted on said stem interiorly of said cone.

11. In a grain-drier, a discharge-element comprising an inverted cone having an opening in its lower end, in combination with a stirrup depending from the sides of said cone below said opening and having a vertical aperture concentric therewith, a vertical screw-stem mounted in said aperture and vertically

adjustable therein, means for vertically adjusting said stem, means for fixing said stem in position with respect to said stirrup, a regulating-element mounted on said stem interiorly of said cone, and a secondary regulating-element above and surrounding said first-named regulating element.

12. In a grain-drier, a discharge-element comprising an inverted cone having an opening in its lower end, in combination with a stirrup depending from the sides of said cone below said opening and having a vertical aperture concentric therewith, a vertical screw-stem mounted in said aperture and vertically adjustable therein, means for vertically adjusting said stem, means for fixing said stem in position with respect to said stirrup, a regulating-element mounted on said stem interiorly of said cone, and a discharge-regulating-element adapted to partially or wholly close the aperture in said cone, said last-named element being adjustably mounted on said stem.

13. A grain-drier comprising a heating-tank having a plurality of vertical tubes adapted for the passage of grain therethrough, a discharge-element comprising an inverted cone having a margin telescoping over the lower end of said tank, a plurality of bracket-shaped ears secured to said tank above said margin and overlapping the latter, and a plurality of devices carried by said ears adapted to clamp against said margin and hold it in place.

14. A grain-drier comprising a substantially cylindrical heating-tank having a plurality of longitudinal tubes adapted for the passage of grain therethrough, a discharge-element comprising an inverted cone secured over the lower end of said tank and having a discharge-orifice at the lower end, and a vertically adjustable regulating-element within said cone adapted to cause the grain passing through said tubes to be evenly distributed among said tubes.

15. A grain-drier comprising a substantially cylindrical heating-tank having a plurality of longitudinal tubes adapted for the passage of grain therethrough, a discharge-element comprising an inverted cone secured over the lower end of said tank and having a discharge orifice at the lower end, a vertically adjustable regulating-element within said cone adapted to cause the grain passing through said tubes to be evenly distributed among said tubes, and a secondary annular regulating-element above and surrounding said first-named element.

16. A grain-drier comprising a substantially cylindrical heating-tank having a plurality of longitudinal tubes adapted for the passage of grain therethrough, a discharge-element comprising an inverted cone secured over the lower end of said tank and having a discharge-orifice at the lower end, a vertically

adjustable regulating-element within said cone adapted to cause the grain passing through said tubes to be evenly distributed among said tubes, a secondary annular regulating-element above and surrounding said first-named element, and a vertically adjustable plug adapted to partially or wholly close the orifice in said discharge-cone.

17. A grain-drier comprising a substantially cylindrical heating-tank having a plurality of vertical tubes, a discharge-element comprising an inverted cone inclosing the lower end of said tank and having a discharge-orifice at its lower end, a vertically adjustable upright regulating-cone mounted within said discharge-cone, and a conical plug adapted to regulate the discharge through said orifice.

18. A grain-drier comprising a substantially cylindrical heating-tank having a plurality of vertical tubes therein, a discharge-regulating-element comprising an inverted cone inclosing the lower end of said tank and having a discharge-orifice at its lower end, an upright screw-stem mounted concentrically and passing through said orifice, an upright regulating-cone mounted on the upper end of said screw-stem, a secondary regulating-ring above and surrounding said regulating-cone, means for adjusting the height of said screw-stem, a conical plug mounted on said screw-stem, and a nut engaging said stem and supporting said conical plug.

19. In a grain-drier, in combination with a heating-tube adapted for the passage of grain therethrough, a movable choke-ring on the interior of said tube.

20. In a grain-drier, in combination with a tube adapted for the passage of grain there-through, a spring-ring adapted to choke the tubular passage and springing against the sides thereof.

21. In a grain-drier, the combination of a heating-tank having a plurality of tubes adapted for the passage of grain there-through, and a plurality of movable choke-rings mounted in said tubes.

22. In a grain-drier, the combination of a heating-tank having a plurality of tubes adapted for the passage of grain there-through, and a plurality of spring-rings choking the tubular passages and held in place by spring-pressure thereagainst.

23. In a grain-drier, in combination with a heating-tank having a plurality of tubes adapted for the passage of grain there-through and fixed at their upper ends in the head of said tank, a funnel-plate fitting over said tank-head comprising a sheet having holes registering with the tubular openings and having its surface formed into ridges with sides sloping downwardly toward said openings, whereby grain alighting on the surface of said plate is caused to slide into one of said openings.

24. A grain-drier comprising a heating-tank having a plurality of vertical tubes, movable choke-rings within said tubes, a funnel-plate above the upper end of said tubes having holes registering with the tubular openings and sides sloping upwardly from said openings, a discharge-cone inclosing the lower end of said tank and having a discharge-orifice at its lower end, an upright regulating-cone vertically adjustable within said discharge-cone, and a plug adapted to regulate the flow of grain through said orifice.

25. In a grain-drier, a heating-tank having a plurality of tubes whose ends pass through one head thereof, said tubes having ends flanged outwardly exterior to said head and the flanges slightly separated therefrom, and rings of metal alloying with said tubes and head filling the annular crevices between said flanges and head.

26. In a grain-drier, a heater comprising a tank having a plurality of tubes whose ends pass through holes in the heads thereof, said tubes having their outer ends expanded to form flanges surrounding the orifices and separated by annular crevices, and a layer of said metal covering the interior surface of said head and the joints of the tubes.

27. A grain-drier comprising a cylindrical drying-element through which grain is adapted to pass, a conical discharge-element having a cylindrical margin telescoping over the end of said drier-element, and a pair of ears on said drying-element adapted to seize and maintain said discharge-element in such position that the conical-portion abuts closely against the end of said drying-element.

28. A grain-drier comprising a cylindrical drying-element, a conical discharge-element adapted to regulate the flow of grain there-through and having a cylindrical margin telescoping over the end of said drying-element, said discharge-element having a roll or bead formed on the edge of said cylindrical margin, and a pair of ears on opposite sides of said drying-element adapted to grasp and hold said bead when said discharge-element telescopes over said drying-element as aforesaid and the latter abuts against the conical-portion of said discharge-element.

29. In a grain-drier, the combination of a discharge-element comprising an inverted cone having an orifice at its lower end, a support beneath said orifice and concentric therewith, a vertical stem mounted and adjustable in said support, a regulating-element mounted on said stem within said cone, and a guide-piece surrounding said stem below said regulating-element within said cone and supported from the walls of the latter.

30. In a grain-drier, the combination of a discharge-element comprising an inverted cone having an orifice at its lower end, a sup-

port beneath said orifice and concentric therewith, a vertical stem mounted and adjustable in said support, a regulating-element mounted on said stem within said cone, a
 5 guide-piece surrounding said stem below said regulating-element within said cone and supported from the walls of the latter, and a secondary regulating-element comprising a ring mounted within said cone concentric
 10 with said first-named regulating-element and over the latter.

31. In a grain-drier, a tube-joint comprising a tube-end having its margin expanded to form a flange, a metal sheet
 15 through which said tube-end passes and the surface of which is slightly separated from said flange so as to form an annular crevice, and a ring of metal filling said crevice and alloying with said tube-end and sheet.

32. In a grain-drier, a tube-joint comprising a tube-end having its margin expanded to form a flange, a metal sheet through which
 20 said tube-end passes and the surface of which is slightly separated from said flange so as to form an annular crevice, a ring of metal filling said crevice and alloying with said tube-end and sheet, and a layer of metal covering
 25 the interior of the line of junction between said tube-end and sheet.

33. In a grain-drier, in combination with

a discharge-cone having an opening at its lower end, a support carried thereby below said open end, a grain-deflector within said cone adjustably mounted on said support, and a flow-regulating plug in said open end
 35 and likewise adjustably mounted on said support.

34. In a grain drier, in combination with a discharge-cone having an opening at its lower end, a support mounted on said discharge-cone below said open end, a vertical stem rising from said support into the interior of said cone, a grain-deflector mounted on said support, means for vertically adjusting said grain-deflector from the exterior
 40 of said cone, and a regulating plug for said lower end adjustably mounted on said stem.

35. In a grain-drier, the combination of a heating-tank having passageways for grain, a distributing-cone covering the lower end
 50 of said tank, an adjustable grain-deflector within said cone, and means operated from the exterior of the apparatus at a point below said tank for regulating said grain-deflector.

In witness whereof I have hereunto set my
 55 hand this 12th day of August, 1905.

PETER PROVOST.

In presence of—

OVIDIA TROSDAHL,
 W. A. PEN GILLY.