



- (51) **International Patent Classification:**  
A47C 23/04 (2006.01) A47C 31/00 (2006.01)
- (21) **International Application Number:**  
PCT/US2024/012790
- (22) **International Filing Date:**  
24 January 2024 (24.01.2024)
- (25) **Filing Language:** English
- (26) **Publication Language:** English
- (30) **Priority Data:**  
63/481,504 25 January 2023 (25.01.2023) US
- (71) **Applicant: SEALY TECHNOLOGY, LLC** [US/US];  
One Office Parkway, Trinity, North Carolina 27370 (US).
- (72) **Inventors: SWITZER, Stephen;** c/o Sealy Technology LLC, One Office Parkway, Trinity, North Carolina 27370 (US). **GHANEI, Hamid;** c/o Sealy Technology LLC, One Office Parkway, Trinity, North Carolina 27370 (US). **CHANDLER, Kelly;** c/o Sealy Technology LLC, One Office Parkway, Trinity, North Carolina 27370 (US). **MICKLOS, James;** c/o Sealy Technology LLC, One Office Parkway, Trinity, North Carolina 27370 (US).

(74) **Agent: WRIGHT, Terry L.** et al.; c/o Stites & Harbison, PLLC, 400 West Market Street, Suite 1800, Louisville, Kentucky 40202 (US).

(81) **Designated States** (*unless otherwise indicated, for every kind of national protection available*): AE, AG, AL, AM, AO, AT, AU, AZ, BA, BB, BG, BH, BN, BR, BW, BY, BZ, CA, CH, CL, CN, CO, CR, CU, CV, CZ, DE, DJ, DK, DM, DO, DZ, EC, EE, EG, ES, FI, GB, GD, GE, GH, GM, GT, HN, HR, HU, ID, IL, IN, IQ, IR, IS, IT, JM, JO, JP, KE, KG, KH, KN, KP, KR, KW, KZ, LA, LC, LK, LR, LS, LU, LY, MA, MD, MG, MK, MN, MU, MW, MX, MY, MZ, NA, NG, NI, NO, NZ, OM, PA, PE, PG, PH, PL, PT, QA, RO, RS, RU, RW, SA, SC, SD, SE, SG, SK, SL, ST, SV, SY, TH, TJ, TM, TN, TR, TT, TZ, UA, UG, US, UZ, VC, VN, WS, ZA, ZM, ZW.

(84) **Designated States** (*unless otherwise indicated, for every kind of regional protection available*): ARIPO (BW, CV, GH, GM, KE, LR, LS, MW, MZ, NA, RW, SC, SD, SL, ST, SZ, TZ, UG, ZM, ZW), Eurasian (AM, AZ, BY, KG, KZ, RU, TJ, TM), European (AL, AT, BE, BG, CH, CY, CZ, DE, DK, EE, ES, FI, FR, GB, GR, HR, HU, IE, IS, IT, LT, LU, LV, MC, ME, MK, MT, NL, NO, PL, PT, RO, RS, SE, SI, SK, SM, TR), OAPI (BF, BJ, CF, CG, CI, CM, GA, GN, GQ, GW, KM, ML, MR, NE, SN, TD, TG).



WO 2024/158917 A2

(54) **Title:** SUPPORT CUSHIONS INCLUDING ELECTRICALLY CONDUCTIVE FABRIC

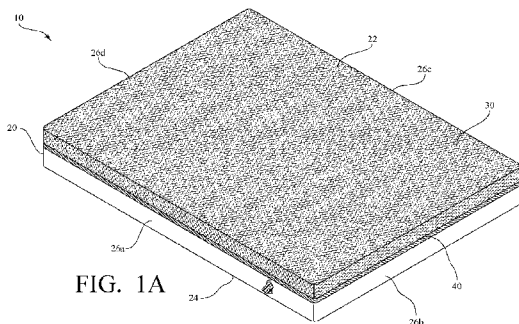

FIG. 1A

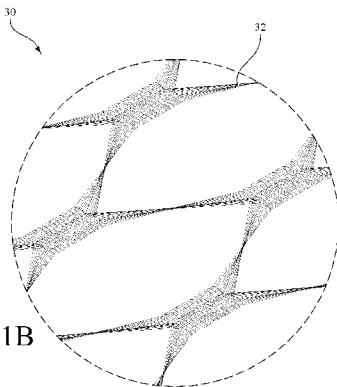

FIG. 1B

(57) **Abstract:** A support cushion comprises a body support portion having a first surface and a second surface opposite the first surface. An electrically conductive fabric is positioned atop the support cushion and draws heat away from the surface of the support cushion, or a plurality of thermoelectric elements are positioned and configured to selectively provide heating or cooling at the surface of the body support portion. Methods of making a support cushion are also provided and include metalizing a fabric substrate with a first metal, and applying the metalized fabric substrate to a body support cushion. The electrically conductive fabric and thermoelectric elements can also be included in a method of controlling the surface temperature of a support cushion, whereby an electrical current is supplied in a first direction to decrease the surface temperature of the support cushion, and a second direction to increase the surface temperature of the support cushion.

**Declarations under Rule 4.17:**

- *as to applicant's entitlement to apply for and be granted a patent (Rule 4.17(ii))*
- *as to the applicant's entitlement to claim the priority of the earlier application (Rule 4.17(iii))*

**Published:**

- *without international search report and to be republished upon receipt of that report (Rule 48.2(g))*

## **SUPPORT CUSHIONS INCLUDING ELECTRICALLY CONDUCTIVE FABRIC**

### **RELATED APPLICATIONS**

[0001] This application claims priority from U.S. Provisional Application Serial No. 63/481,504, filed January 25, 2023, the entire disclosure of which is incorporated herein by this reference.

### **TECHNICAL FIELD**

[0002] The present invention relates to support cushions including an electrically conductive fabric. In particular, the present invention relates to support cushions including an electrically conductive fabric that is positioned and configured to passively or actively dissipate heat away from the surfaces of the support cushions and into the surrounding environment.

### **BACKGROUND**

[0003] An aspect of successful and restful sleep is individual sleep comfort. Medical research suggests that sleep deprivation (“sleep debt”) can have significant negative impacts on longevity, productivity, and overall mental, emotional, and physical health. Chronic sleep debt has been linked to weight gain and, more specifically, has been observed to not only affect the way the body processes and stores carbohydrates, but has also been observed to alter hormone levels that affect appetite. Moreover, sleep debt may result in irritability, impatience, inability to concentrate, and moodiness, which has led some researchers to suggest a link between sleep debt and worksite accidents, traffic incidents, and general afternoon inattentiveness. Furthermore, sleep disorders have been linked to hypertension, increased stress hormone levels, and irregular heartbeat, and additional research has recently suggested that a lack of sleep can affect immune

function, resulting in increased susceptibility to illness and disease, e.g., cancer. In all, researchers have now suggested that sleep debt costs the United States billions of dollars annually in lost productivity due to these various effects. Accordingly, a support cushion that improves sleep comfort and lowers individual sleep debt would be both highly desirable and beneficial.

### SUMMARY

**[0004]** The present invention includes support cushions comprising an electrically conductive fabric. In particular, the present invention includes support cushions comprising an electrically conductive fabric that is positioned and configured to passively or actively dissipate heat away from the surfaces of the support cushions and into the surrounding environment, and that thereby improves sleep comfort by providing a means to dissipate heat away from the surface of the support cushion.

**[0005]** In some exemplary embodiments of the present invention, a support cushion is provided that comprises a body support portion having a first surface and a second surface opposite the first surface. An electrically conductive fabric is positioned atop the body support portion and is configured to draw heat away from the first surface of the support cushion. The electrically conductive fabric, to provide such heat dissipation, comprises a first metal bonded to a substrate. In certain embodiments, the substrate of that electrically conductive fabric is nylon, while the first metal comprises silver.

**[0006]** In some embodiments of the body support cushions of the present invention, the body support cushion includes four sides defining a perimeter of the support cushion, and a second metal extends along at least a portion of the perimeter with the second metal connected to the first metal of the electrically conductive fabric. In some such embodiments, the second metal is comprised of a strip of a metal foil that extends around the perimeter of the support cushion and

that, in some embodiments, is sewn to the electrically conductive fabric. In some embodiments, the electrically conductive fabric is in the form of a stretched knit fabric, and the substrate is a thread or yarn

**[0007]** To allow heat to be effectively and efficiently transferred away from the surface of the support cushion, in some embodiments, the first metal has a first thermal conductivity and the second metal has a second thermal conductivity. The first thermal conductivity and the second thermal conductivity are each higher than a thermal conductivity of the body support portion and, in turn, creates a system in which heat is drawn from the surface of the support cushion towards the second metal and then is allowed to dissipate into the surrounding environment. In some embodiments of such a passive system, the first metal comprises silver and the second metal comprises tin.

**[0008]** With regard to the body support portion of an exemplary support cushion of the present invention, in some embodiments, the body support portion is dimensionally-sized to support a user lying in a supine or prone position and, in certain embodiments, is comprised of a visco-elastic foam. In other embodiments, however, the body support portion is comprised of a plurality of coiled springs positioned between the first surface and the second surface, either by themselves or in addition to an amount of flexible foam. In some such embodiments that make use of a plurality of coiled springs in an exemplary support cushion, the coiled springs are operably connected to the first metal of the electrically conductive fabric.

**[0009]** Further provided, in some implementations of the present invention are methods for making a support cushion including an electrically conductive fabric. In some implementations, a method of making a support cushion is provided that comprises an initial step of metalizing a fabric substrate with a first metal to create an electrically conductive fabric, and then a second

step of applying the metalized fabric substrate to the body support cushion. For instance, in certain embodiments, the fabric substrate is metalized by applying a silver solution to a fabric substrate that includes a nylon, and then reducing the silver solution such that the silver in the solution bonds to the nylon and creates the electrically conductive fabric. In some embodiments, such a silver solution comprises silver nitrate.

**[0010]** Similar to the support cushions described above, in certain implementations of an exemplary method of making a support cushion in accordance with the present invention, the support cushion is made to further include a second metal that is connected to the first metal of the electrically conductive fabric. Again, in some such embodiments, the second metal comprises a strip of a metal foil extending around the perimeter of the support cushion, or comprises a plurality of coil springs that are included in the body support cushion, such that the first metal can have a first thermal conductivity and the second metal can have a second thermal conductivity that are each greater than a thermal conductivity of the body support cushion to thereby allow heat to be dissipated away from the body support cushion.

**[0011]** Still further provided, in some embodiments of the support cushions of the present invention, are support cushions that rather than relying on passive mechanisms to dissipate heat away from a surface of the support cushion, instead rely on more active mechanisms to dissipate heat. For example, in some embodiments, a support cushion made in accordance with the present invention includes a body support portion having a first surface and a second surface opposite the first surface, and a plurality of thermoelectric elements that are positioned and configured to selectively provide heating or cooling at the first surface of the body supporting portion. Each of the plurality of thermoelectric elements, in some embodiments, are comprised of an electrically conductive fabric that includes a first metal bonded to a substrate.

**[0012]** To dissipate heat away from the surface of the support cushion in such an active system, the electrically conductive fabric of each of the plurality of thermoelectric elements extends across the first surface of the body support portion. The body support portion then also includes a plurality of columnar voids, with each columnar void including at least a portion of the thermoelectric elements. A base portion of the support cushion is positioned below and spaced apart from the second surface of the body support portion, and is separated from the body support portion by an air conduit that includes an inlet and an outlet. A portion of the thermoelectric elements extend into the air conduit and a fan is operably connected to the outlet of the air conduit to allow any heat pulled from the first surface to the second surface of the body support portion to be dissipated out of the air conduit and away from the support cushion. In some embodiments of the active systems, a power supply is included to supply an electrical current to the thermoelectric elements, along with a controller to control the electrical current supplied to the thermoelectric elements from the power supply.

**[0013]** With further regard to the active systems described herein, in some implementations, methods of controlling the surface temperature of a support cushion with an active system are further provided. In some implementations, a method of controlling the surface temperature of a support cushion with an exemplary active system comprises an initial step of providing a support cushion that includes a body support portion and a plurality of thermoelectric elements including an electrically conductive fabric comprising a first metal bonded to a substrate. An electrical current is then supplied to the plurality of thermoelectric elements, such that the electrical current is supplied in a first direction to decrease the surface temperature of the body support portion, and such that electrical current is supplied in a second direction to increase the surface temperature of the body support portion.

[0014] Further features and advantages of the present invention will become evident to those of ordinary skill in the art after a study of the description, figures, and non-limiting examples in this document.

### **BRIEF DESCRIPTION OF THE DRAWINGS**

[0015] **FIG. 1A** is a perspective view of a support cushion including an electrically conductive fabric and made in accordance with the present invention, and with a portion of the lower part of cover of the support cushion removed to show the underlying foam included in the support cushion;

[0016] **FIG. 1B** is a partial view of the electrically conductive fabric included in the support cushion shown in FIG. 1A;

[0017] **FIG. 2A** is a perspective view of another support cushion including an electrically conductive fabric and made in accordance with the present invention, and with a portion of the lower part of the cover of the support cushion removed to show the underlying springs included in the support cushion;

[0018] **FIG. 2B** is a partial view of the electrically conductive fabric included in the support cushion shown in FIG. 2A and showing the electrically conductive fabric connected to the underlying springs included in the support cushion;

[0019] **FIG. 3** is a perspective view of another support cushion including a plurality of thermoelectric elements comprised, in part, of an electrically conductive fabric and made in accordance with the present invention;

[0020] FIG. 4 is a cross-sectional view of another support cushion including a plurality of thermoelectric elements comprised, in part, of an electrically conductive fabric and made in accordance with the present invention; and

[0021] FIG. 5 is a cross-sectional view of another support cushion including a plurality of thermoelectric elements comprised, in part, of an electrically conductive fabric and made in accordance with the present invention.

### DESCRIPTION OF EXEMPLARY EMBODIMENTS

[0022] The present invention includes support cushions comprised of an electrically conductive fabric. In particular, the present invention includes support cushions comprised of an electrically conductive fabric that is positioned and configured to passively or actively dissipate heat away from the surfaces of the support cushion and into the surrounding environment. By making use of the electrically conductive fabrics, the support cushions of the present invention thus allow a user to improve their sleep comfort by avoiding an increase in the surface temperature of the support cushion that would otherwise affect the user's sleep.

[0023] Referring first to FIG. 1A, in one exemplary embodiment of the present invention, a support cushion in the form of a mattress assembly 10 is provided that includes a body support portion 20 having a first surface 22, which is usually an upper surface of the body support portion 20, and a second surface 24, which is generally the lower surface of the body support portion 20 and is opposite the first surface 22. The body support portion 20 of the mattress assembly 10 also additionally includes four sides 26a, 26b, 26c, 26d that define a perimeter of the mattress assembly 10. The mattress assembly 10 further includes an electrically conductive fabric 30 that is comprised of a first metal bonded to an underlying substrate. The electrically

conductive fabric 30 is positioned atop the body support portion 20 of the mattress assembly 10 and, along with a second metal that is in the form of a metal strip 40 extending around the perimeter of the mattress assembly 10, is configured to draw heat away from the first surface 22 of the mattress assembly 10, as described in further detail below.

**[0024]** As perhaps shown best in the partial view of the electrically conductive fabric 30 in FIG. 1B, the electrically conductive fabric 30 included in the exemplary mattress assembly 10 is a stretched knit or woven fabric that is comprised of a plurality of individual yarns 32, with each yarn 32 coated with the first metal before being assembled into the knit or woven configuration. In particular, in the electrically conductive fabric 30, the yarn 32 making up the electrically conductive fabric 30 is comprised of a nylon that is first coated with silver before being arranged in the knit or woven configuration. In this way, by coating the yarn 32 in such a manner, it has been observed that the electrically conductive fabric 30 is imparted with a degree of durability and stretch-ability that allows the electrically conductive fabric 30 to not only be stretched across a bed and effectively utilized on such a surface, but is also able to withstand damage that may be caused by typical wear and tear. In contrast to mattress assemblies that incorporate wire-based systems into a mattress to provide heating and/or cooling, the stretch knit configuration and construction of the present invention, which makes use of the metallized coated yarns 32 to form the electrically conductive fabric 30, do not readily break or come apart and continue to be capable of conducting electricity or heat after being subjected to repeated articulation, bouncing, or other tests to its durability that are encountered during normal use of the mattress assembly 10.

**[0025]** As would be recognized by those skilled in the art, numerous methods can be used to coat or otherwise incorporate a metal into an underlying substrate including, but not limited to,

printing, padding, direct coating, vapor deposition, and the like. Such methods can be used to apply a metal to a substrate in a variety of different patterns and configurations. To coat the nylon comprising the yarn 32 with silver in the electrically conductive fabric 30, however, the nylon is typically first coated with a silver nitrate solution that then undergoes a reduction reaction to create an ionic bond between the nylon and the silver. In this regard, in some embodiments, a chemical plating solution can be utilized in which silver nitrate, a reducing agent, and certain complexing agents (e.g., an alkali, a buffer, and a stabilizer) are typically used to control and promote the autocatalytic process for the production of the coated yarns. Such reagents for a reduction reaction that allow for the production of the silver-coated nylon yarns can include stannous chloride, hydrochloric acid, silver nitrate, sodium hydroxide, and an ammonium solution. Of course, as would be also appreciated by those skilled in the art, a variety of other activators and reagents can also be selected for a particular reaction and can be selected depending on the particular metal utilized and the materials included in the underlying substrate (e.g., the yarn) without departing from the spirit and scope of the subject matter described herein. Without wishing to be bound by any particular theory or mechanism, however, it is believed that by making use of a metalizing process that coats an underlying substrate such as the silver/nylon reduction reaction described above, an electrically conductive fabric can be produced that is more durable than a printed or padded application as the ionic bond created during the reaction allows for a bond that is more durable to abrasion and that will not lose its adhesion to the substrate over time, as is often the case with other coating applications or with printing.

**[0026]** Referring still to FIGS. 1A-1B, to effectively assist in drawing heat away from the first surface 22 of the body support portion 20, the second metal extending along the perimeter of the mattress assembly 10 is generally connected to the first metal of the electrically conductive

fabric 30. In the exemplary mattress assembly 10, the metal strip 40 is formed from a metal foil that allows the metal strip 40 to be sewn directly to the electrically conductive fabric 30. In this way, and while the use of wire connectors, clips, soldering, and the like can also be used to operably connect the electrically conductive fabric 30 to the metal strip 40 and are contemplated to be within the scope of the present invention, the sewing of the electrically conductive fabric 30 directly to the metal strip 40 allows electrical current and heat to be efficiently transmitted or otherwise easily conducted from the electrically conductive fabric 30 to the metal strip 40, such that the heat can be transferred and then dissipate into the surrounding environment.

**[0027]** To allow heat to be effectively and efficiently transferred from the upper surface 22 of the mattress assembly 10, such as what may occur when a user is resting on the upper surface 22 of the mattress assembly 10 for a period of time, the first metal included in the electrically conductive fabric 30 generally has a first thermal conductivity and the second metal comprising the metal strip 40 generally has a second thermal conductivity with both the first thermal conductivity and the second thermal conductivity being higher than the foam or other similar insulating material used to produce the body support cushion 20, as described in further detail below. As such, when a user rests on the upper surface 22 of the body support cushion 20 and heat accumulates at the upper surface 22, heat is then drawn from the upper surface 22, through the first metal in the electrically conductive fabric 30, and towards the second metal in the metal strip 40 extending around the perimeter of the mattress assembly 10. Once the heat transfers to the metal strip 40, it is then able to dissipate into the surrounding environment and away both from the first surface 22 of the body support portion 20 and from the user resting on that first surface 22. In this way, the exemplary mattress assembly 10 thus provides a passive system in which heat can be dissipated away from the sleeping surface of the mattress assembly 10 through

the course of a given sleep period without the use of electricity or other external input into the mattress assembly 10.

**[0028]** With further regard to the first and second metals included in an exemplary support cushion of the present invention, in the exemplary mattress assembly 10, the first metal included in the electrically conductive fabric 30 is silver while the second metal included in the metal strip 40 comprises tin, both of which are generally more thermally conductive than the foam or other similar insulating material used to produce the body support cushion 20. The silver in the electrically conductive fabric 30 and the tin in the metal strip 40 thus allows for the creation of a thermal gradient or heat sink in which heat is conducted from the insulating body support cushion to the silver in the electrically conductive fabric 30 and then to the tin of the metal strip 40 where it is then exposed to and released into the surrounding environments from the sides 26a, 26b, 26c, 26d of the mattress assembly 10. Of course, it is further contemplated that other metals, including, but not limited to copper, nickel, aluminum, and the like, can also be incorporated into an exemplary support cushion to allow for a thermal gradient to be established and can readily be selected for a particular application without departing from the spirit and scope of the subject matter described herein. In some embodiments, it is contemplated that the first metal and the second metal, as well as their associated thermal conductivities, are the same.

**[0029]** Turning now to the body support cushion or portion 20 itself, the body support portion 20 of the mattress assembly 10 is generally comprised of a continuous layer of flexible foam that is capable of suitably distributing pressure from a user's body or portion thereof across the body supporting portion 20, but that may be prone to retaining heat given the nature of the foam. Such flexible foams include, but are not limited to, latex foam, reticulated or non-reticulated visco-elastic foam (sometimes referred to as memory foam or low-resilience foam),

reticulated or non-reticulated non-visco-elastic foam, polyurethane high-resilience foam, expanded polymer foams (e.g., expanded ethylene vinyl acetate, polypropylene, polystyrene, or polyethylene), and the like. In the embodiment shown in FIG. 1, the body support portion 20 is comprised of a visco-elastic foam that has a low resilience as well as a sufficient density and hardness, which allows pressure to be absorbed uniformly and distributed evenly across the body supporting portion 20 of the mattress assembly 10. Generally, such visco-elastic foams have a hardness of at least about 10 N to no greater than about 80 N, as measured by exerting pressure from a plate against a sample of the material to a compression of at least 40% of an original thickness of the material at approximately room temperature (i.e., 21°C to 23°C), where the 40% compression is held for a set period of time as established by the International Organization of Standardization (ISO) 2439 hardness measuring standard. In some embodiments, the visco-elastic foam has a hardness of about 10 N, about 20 N, about 30 N, about 40 N, about 50 N, about 60 N, about 70 N, or about 80 N to provide a desired degree of comfort and body-conforming qualities.

**[0030]** The visco-elastic foam described herein for use in the mattress assembly 10 can also have a density that assists in providing a desired degree of comfort and body-conforming qualities, as well as an increased degree of material durability. In some embodiments, the density of the visco-elastic foam used in the body supporting portion 20 has a density of no less than about 30 kg/m<sup>3</sup> to no greater than about 150 kg/m<sup>3</sup>. In some embodiments, the density of the visco-elastic foam used in the body supporting portion 20 of the mattress assembly 10 is about 30 kg/m<sup>3</sup>, about 40 kg/m<sup>3</sup>, about 50 kg/m<sup>3</sup>, about 60 kg/m<sup>3</sup>, about 70 kg/m<sup>3</sup>, about 80 kg/m<sup>3</sup>, about 90 kg/m<sup>3</sup>, about 100 kg/m<sup>3</sup>, about 110 kg/m<sup>3</sup>, about 120 kg/m<sup>3</sup>, about 130 kg/m<sup>3</sup>, about 140 kg/m<sup>3</sup>, or about 150 kg/m<sup>3</sup>. Of course, the selection of a visco-elastic foam having a

particular density will affect other characteristics of the foam, including its hardness, the manner in which the foam responds to pressure, and the overall feel of the foam, but it is appreciated that a visco-elastic foam having a desired density and hardness can also readily be selected for a particular application or mattress assembly as desired.

[0031] Additionally, it is appreciated that the body supporting portions of the mattress assemblies of the present invention need not be comprised of a continuous layer of flexible foam at all, but can also take the form of more traditional mattresses, including spring-based mattresses, without departing from the spirit and scope of the subject matter described herein. For instance, and referring now to FIGS. 2A-2B, in another exemplary embodiment of the present invention, a mattress assembly 110 is provided that includes a body support portion 120 that has a first surface 122 and a second surface 124 opposite the first surface 122, and that additionally includes four sides 126a, 126b, 126c, 126d that define a perimeter of the mattress assembly 110. Like the mattress assembly 10 shown in FIGS. 1A-1B, the mattress assembly 110 also includes an electrically conductive fabric 130 that is comprised of a first metal bonded to an underlying substrate. In the mattress assembly 110, however, the body support portion 120 is not primarily comprised of a flexible foam, but is instead comprised of a plurality of open coil springs 140. In this way, rather than connecting the electrically conductive fabric 130 to a metal strip extending around the perimeter of the mattress assembly 110, the electrically conductive fabric 130 is connected directly to the open coil springs 140 (e.g., by one or more coated conductive yarns or wires 141 (as shown in FIG. 2B) or by ribbons comprising a portion of the electrically conductive fabric 130), which, like the first metal included in the electrically conductive fabric 130, are generally more thermally conductive than first surface 122 of the body support portion 120, particularly when the first surface 122 of the body support cushion 120 is

comprised of a layer of foam or other insulating padding. In this way, the connection of the electrically conductive fabric 130 to the open coil springs 140 thus allows a thermal gradient to be established in a manner similar to that described above with reference to the mattress assembly 10 shown in FIG. 1. In particular, by making use of the above described conductive fabric 130 connected to the open coil springs 140, heat can be transferred from the first surface 122 of the mattress assembly 110 to the electrically conductive fabric 130 and then to the open coil springs 140 upon a user resting on the first surface of the body support portion 120 for a period of time and upon heat accumulating at that first surface 122. Once the heat is transferred to the open coil springs 140, the heat is able to dissipate inside of the mattress assembly 110 and away from the user.

[0032] Referring now to FIG. 3, while the embodiments shown in FIGS. 1A-1B and FIGS. 2A-2B provide passive systems that allow heat to be dissipated away from a surface of a support cushion, by making use of the electrically conductive fabrics described herein, the support cushions of the present invention also provide a means to actively heat or cool a support cushion through the application of an electrical current to the electrically conductive fabrics. For example, in another exemplary embodiment of the present invention, and as shown in FIG. 3, a support cushion in the form of a mattress assembly 210 is provided that includes a body support portion 220 comprised of a flexible foam and having a first surface 222, a second surface 224 opposite the first surface 222, and four sides 226a, 226b, 226c, 226d that define a perimeter of the mattress assembly 210. The mattress assembly 210 further includes an electrically conductive fabric 230 including a metal coating a substrate (e.g., silver bonded to a nylon yarn) similar to what is described above with reference to FIGS. 1A-1B and FIGS. 2A-2B, but instead of configuring the electrically conductive fabric to be utilized in a passive manner, the

electrically conductive fabric 230 is included as part of a plurality of thermoelectric elements 231 in the form of Peltier elements. Specifically, in the mattress assembly 210, the electrically conductive fabric 230 is in the form a strip that extends and is distributed across the entire upper surface 222 of the body support portion 220, such that the Peltier elements 231 and, more particularly, the electrically conductive fabric 230 is configured to selectively provide heating or cooling at the first surface 222 of the body support portion 220.

**[0033]** The Peltier elements 231, which are included in the mattress assembly 210 and which may also be referred to as Peltier devices, Peltier heaters or heat pumps, solid-state refrigerators or thermoelectric heat pumps, are solid-state active heat pumps which transfer heat from one portion of the body support portion 220 of the mattress assembly 210 to another portion of the body supporting portion 220 by flowing an amount of electrical current through the Peltier elements 231 to produce a Peltier effect or, in other words, the presence of heat at an electrified junction of two different metals. In the Peltier elements 231 shown in FIG. 3, the junctions of two different metals are positioned along a side of 226a of the body support portion 220 and are in the form of a n-type semiconductor or element 232 and a p-type semiconductor or element 234. In these Peltier elements 231, when an amount of electrical current flows in a first direction along a strip of the electrically conductive fabric 230 through the n-type element 232, crosses a metallic interconnect 233 that is also formed of a strip of electrically conductive fabric, and passes into the p-type element 234, a Peltier effect is created whereby electrons in the n-type elements 232 move in the opposite direction of the current and holes in the p-type element 234 move in the direction of current, such that both remove heat from the first surface 222 of the body supporting portion 220 of the mattress assembly 210 and toward the side 226a of the body supporting portion 220 where it is then be dissipated into the surrounding environment. In this

way, by making use of the strips of electrically conductive fabric 230 in place of the wires typically found in a Peltier-type system, the strips of electrically conductive fabric 230 not only allow for the creation of a grid of p-type and n-type semiconductors that allow a user to selectively cool the first surface 222 of the body support portion 220, but the strips of electrically conductive fabric 230 provide an improved alternative to the wires of typical Peltier systems that are prone to breakage and reduce the overall feel and comfort of a mattress assembly. Further, with the inclusion of the Peltier elements 231, upon flowing an amount of electrical current in a second (e.g., opposite) direction through the Peltier elements 231 and the n-type elements 232 and p-type elements 234, the Peltier effect can be reversed and the Peltier elements 231 can be used to heat the first surface 222 of the body supporting portion 220 by drawing heat toward the first surface 222 of the body supporting portion 220.

**[0034]** As a refinement of the active systems of the present invention, although the electrically conductive fabric 230 included in the Peltier elements 231 shown in FIG. 3 are arranged with the strips of electrically conductive fabric 230 positioned atop and spanning the width of the first surface 222 of the body support portion 220, it is contemplated that the electrically conductive fabric 230 can also be used in various other arrangements of thermoelectric elements. For instance and referring now to FIG. 4, in another exemplary support cushion in the form of a mattress assembly 310 of the present invention, the Peltier elements 331 substantially span the width of a body support portion 320 of the mattress assembly 310 such that a strip of the electrically conductive fabric 330 forming each of the Peltier elements 331 is positioned above and adjacent to the first surface 322 of the body support portion 320, and the metallic interconnects 333 of the Peltier elements 331 are positioned below and adjacent to the second surface 324 of the body support portion 320.

**[0035]** To allow the Peltier elements 331 to pass through the body support portion 320, the body support portion 320 includes a plurality of columnar voids 326 where parts of the body support portion 320 have been removed to allow a portion of the Peltier elements 331, including the n-type elements 332 and the p-type elements 334, to be positioned in and pass through the body supporting portion 320 and to allow heat to be transferred from one surface of the body supporting portion 320 to the other. In other words, the Peltier elements 331 and the electrically conductive fabric 330 are positioned adjacent to the body supporting portion 320 and direct the transfer of heat from one surface of the body support portion 320, through the body support portion 320, and to the other surface of the body support portion 320 where it can then be dissipated into the surrounding environment.

**[0036]** Referring now to FIG. 5, as a further refinement to the active systems described herein, in another embodiment, a mattress assembly 410 is provided that includes the same components as those described with reference to FIG. 4. In particular, the mattress assembly 410 includes the Peltier elements 431 that substantially span the width of a body support portion 420, with a strip of electrically conductive fabric 430 forming each of the Peltier elements 431 and with the metallic interconnects 433 from of the Peltier elements 431 positioned below and adjacent to the second surface 424 of the body support portion 420. A plurality of columnar voids 426 are also included and pass through the body support portion 420 to allow the Peltier elements 431 to pass through the body support portion 420. In addition to those components, however, and to assist in conveying air across the metallic interconnects 433 (e.g., to dissipate heat) the metallic interconnects 433 are housed within an air conduit 470 that includes a space mesh and extends from an air inlet 472 to an air outlet 474. The air conduit 470 is then positioned above a base support portion or cushion 460 and, in operation, a fan 480 positioned at

the air outlet 474 is used to draw air through the air conduit 474, across the metallic interconnects 433 and thereby dissipate heat (or cold) into the surrounding environment.

[0037] Referring now generally to FIGS. 3-5, regardless of the particular arrangement of electrically conductive fabrics 230, 330, 430 in the Peltier elements 231, 331, 431, each mattress assembly 210, 310, 410 of the present invention further includes a power supply 290, 390, 490 for supplying electrical current to the plurality of Peltier elements 231, 331, 431, as well as a controller 280, 380, 480 for controlling the amount and direction of the electrical current that is supplied to the plurality of Peltier elements 231, 331, 431. By including a controller 280, 380, 480 in the mattress assemblies 210, 310, 410, the amount and direction of electrical current supplied to the Peltier elements 231, 331, 431 can be controlled to provide a desired amount of heating or cooling to the first surface 222, 322, 422 of each mattress assembly 210, 310, 410. For example, the controller 280, 380, 480 can be configured to automatically control the electrical current supplied to Peltier elements 231, 331, 431, such that electrical current can be supplied to the Peltier elements 231, 331, 431 to heat or cool the first surface 222, 322, 422 of each body support portion 220, 320, 420 when the first surface 222, 322, 422 of the body support portion 220, 320, 420 reaches a particular temperature, such as after a user has been lying on the body support portion 220, 320, 420 for an extended period of time. As another example, the controllers 280, 380, 480 can also be configured to allow the electrical current to be supplied to the Peltier elements for a predetermined time period, such as for an 8-hour sleeping period.

[0038] Each of the exemplary support cushions described herein can also be used as part of a method of controlling a surface temperature of the support cushion. In some implementations, a method of controlling the surface temperature of a support cushion is provided in which a passive system described herein is utilized and in which an electrically conductive fabric

including a first metal is provided and applied to a body support cushion, onto which a second metal is attached or otherwise included. In other implementations, such as with the active systems described herein, a support cushion is first provided that includes a body support portion and a plurality of thermoelectric elements that include and make use of an electrically conductive fabric comprising a first metal bonded to a substrate. An electrical current is then supplied to the plurality of thermoelectric elements such that the electrical current is supplied in a first direction to decrease the surface temperature of the body support portion, and such that electrical current is supplied in a second direction to increase the surface temperature of the body support portion.

**[0039]** Lastly, although the support cushions shown in FIGS. 1-5 are in the form of mattress assemblies 10, 110, 210, 310, 410, and are generally dimensionally-sized to support a user lying in a supine or prone position, it is contemplated that the features described herein are equally applicable to head pillows, seat cushions, seat backs, neck pillows, leg spacer pillows, mattress toppers, overlays, and the like. As such, the phrase “body support” or “body supporting” is used herein to refer to any and all such objects having any size or shape, and that are capable of or are generally used to support the body of a user or a portion thereof.

**[0040]** One of ordinary skill in the art will recognize that additional embodiments are also possible without departing from the teachings of the present invention or the scope of the claims which follow. This detailed description, and particularly the specific details of the exemplary embodiments disclosed herein, is given primarily for clarity of understanding, and no unnecessary limitations are to be understood therefrom, for modifications will become apparent to those skilled in the art upon reading this disclosure and may be made without departing from the spirit or scope of the claimed invention.

## CLAIMS

What is claimed is:

1. A support cushion, comprising:  
a body support portion having a first surface and a second surface opposite the first surface; and  
an electrically conductive fabric positioned atop and configured to draw heat away from the first surface of the body support portion, the electrically conductive fabric comprising a first metal bonded to a substrate.
2. The support cushion of claim 1, wherein the substrate comprises nylon.
3. The support cushion of claim 1, wherein the first metal comprises silver.
4. The support cushion of claim 1, wherein the body support portion includes four sides defining a perimeter of the support cushion, and  
wherein the support cushion further comprises a second metal extending along at least a portion of the perimeter, the second metal connected to the first metal of the electrically conductive fabric.
5. The support cushion of claim 4, wherein the second metal comprises a strip of a metal foil extending around the perimeter of the support cushion.

6. The support cushion of claim 5, wherein the strip of metal foil is sewn to the electrically conductive fabric.
7. The support cushion of claim 4, wherein the first metal has a first thermal conductivity and the second metal has a second thermal conductivity, and wherein the first thermal conductivity and the second thermal conductivity are each higher than a thermal conductivity of the body support portion.
8. The support cushion of claim 7, wherein the first metal comprises silver and wherein the second metal comprises tin.
9. The support cushion of claim 1, wherein the electrically conductive fabric is in the form of a stretched knit fabric, and wherein the substrate is a thread or yarn.
10. The support cushion of claim 1, wherein the body support portion is comprised of a visco-elastic foam.
11. The support cushion of claim 1, wherein the body support portion comprises a plurality of coiled springs positioned between the first surface and the second surface, and  
wherein the plurality of coiled springs are operably connected to the first metal of the electrically conductive fabric.

12. The support cushion of claim 1, wherein the body support portion is dimensionally-sized to support a user lying in a supine or prone position.
13. A method of making a support cushion, comprising:  
metalizing a fabric substrate with a first metal; and  
applying the metalized fabric substrate to a support cushion.
14. The method of claim 13, wherein metalizing the fabric substrate comprises applying a silver solution to a fabric substrate including a nylon, and reducing the silver solution such that the silver in the solution bonds to the nylon.
15. The method of claim 14, wherein the silver solution comprises silver nitrate.
16. The method of claim 14, wherein the support cushion includes a second metal, the second metal connected to the first metal of the electrically conductive fabric.
17. The method of claim 16, wherein the second metal comprises a strip of a metal foil extending around the perimeter of the support cushion, or a plurality of coil springs included in the support cushion.
18. The method of claim 16, wherein the first metal has a first thermal conductivity and the second metal has a second thermal conductivity, and wherein the first thermal conductivity and

the second thermal conductivity are each greater than a thermal conductivity of the support cushion.

19. A support cushion, comprising:

a body support portion having a first surface and a second surface opposite the first surface; and

a plurality of thermoelectric elements positioned and configured to selectively provide heating or cooling at the first surface of the body support portion, each of the plurality of thermoelectric elements including an electrically conductive fabric comprising a first metal bonded to a substrate.

20. The support cushion of claim 19, wherein the electrically conductive fabric of each of the plurality of thermoelectric elements extends across the first surface of the body support portion.

21. The support cushion of claim 19, wherein the body support portion includes a plurality of columnar voids, and wherein each columnar void includes at least a portion of the thermoelectric elements.

22. The support cushion of claim 21, wherein the support cushion further includes a base portion positioned below and spaced apart from the second surface of the body support portion, the base portion separated from the body support portion by an air conduit including an inlet and an outlet, and

wherein a portion of the thermoelectric elements extend into the air conduit.

23. The support cushion of claim 22, further comprising a fan operably connected to the outlet of the air conduit.
24. The support cushion of claim 19, further comprising a power supply for supplying an electrical current to the thermoelectric elements, and a controller for controlling the electrical current supplied to the thermoelectric elements from the power supply.
25. A method of controlling the surface temperature of a support cushion, comprising:  
providing a support cushion including a body support portion and a plurality of thermoelectric elements including an electrically conductive fabric comprising a first metal bonded to a substrate; and  
supplying an electrical current to the plurality of thermoelectric elements such that the electrical current is supplied in a first direction to decrease the surface temperature of the body support portion, and such that electrical current is supplied in a second direction to increase the surface temperature of the body support portion.

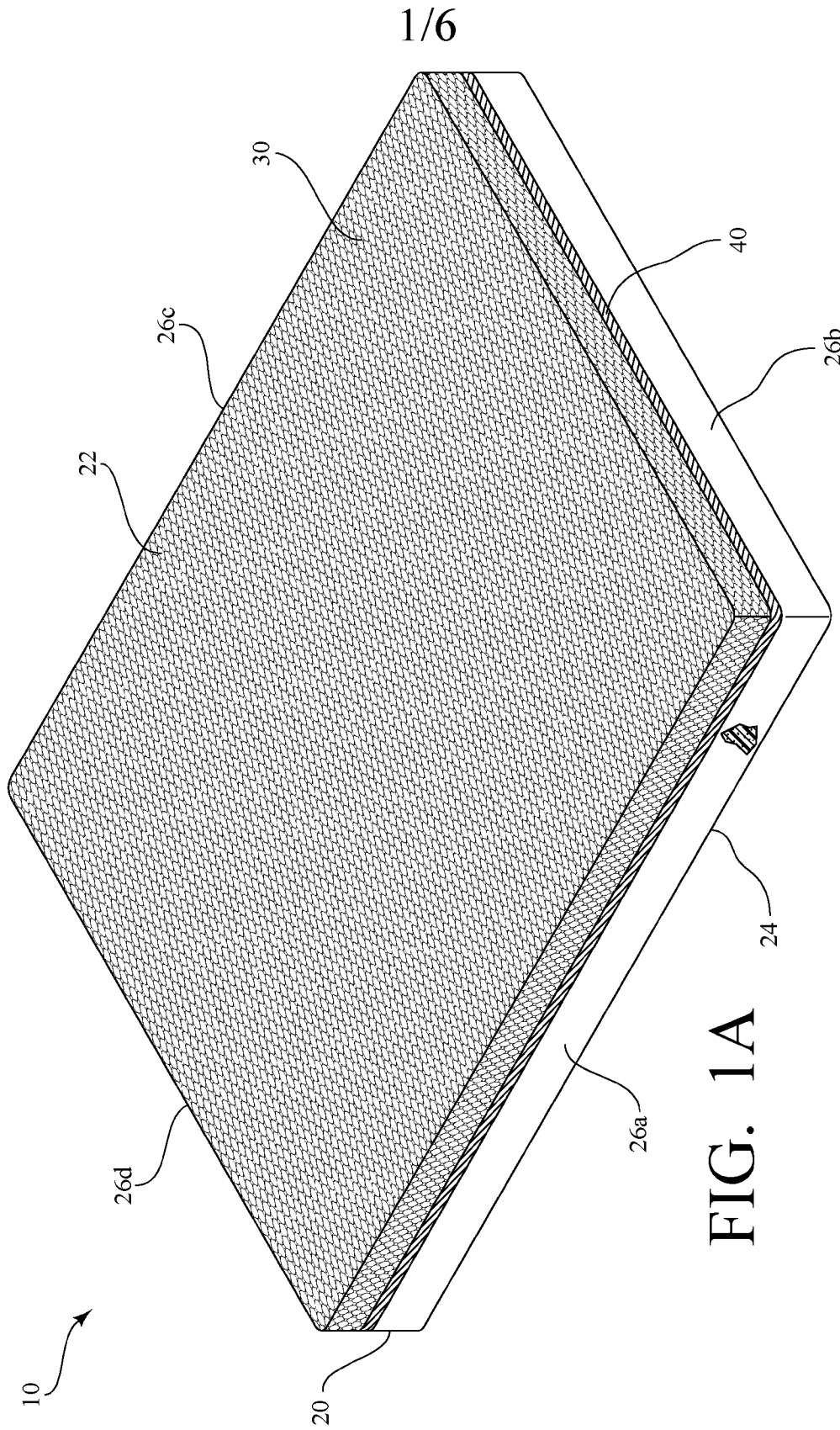

2/6

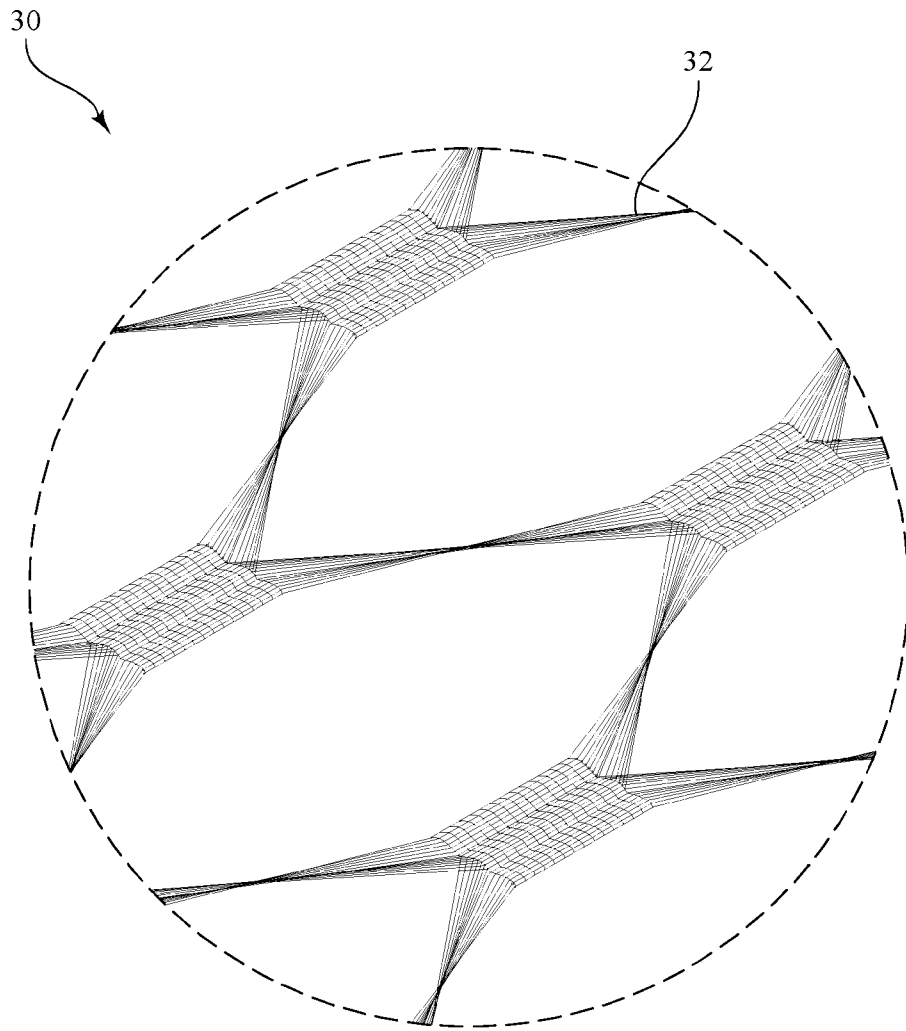

FIG. 1B

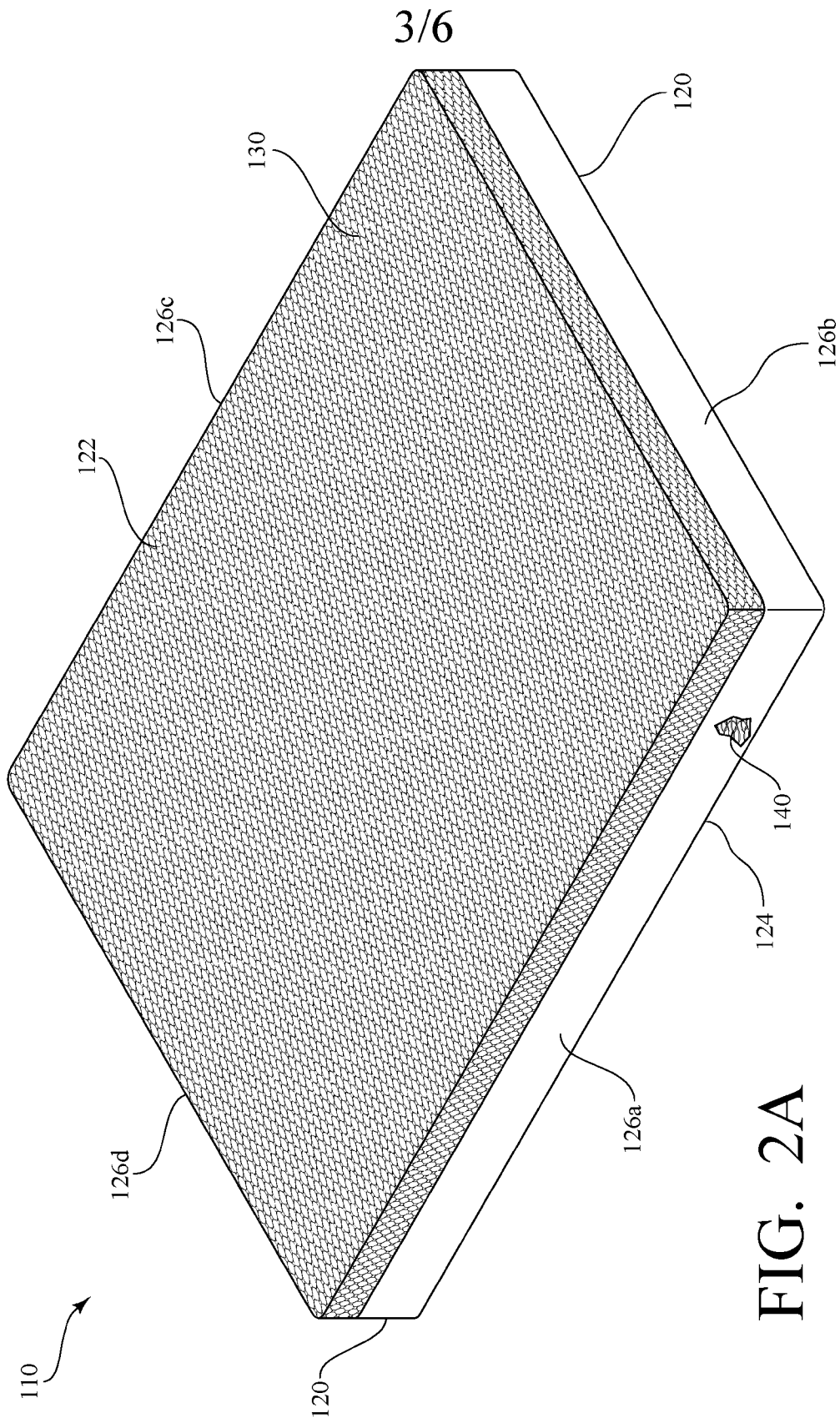

FIG. 2A

4/6

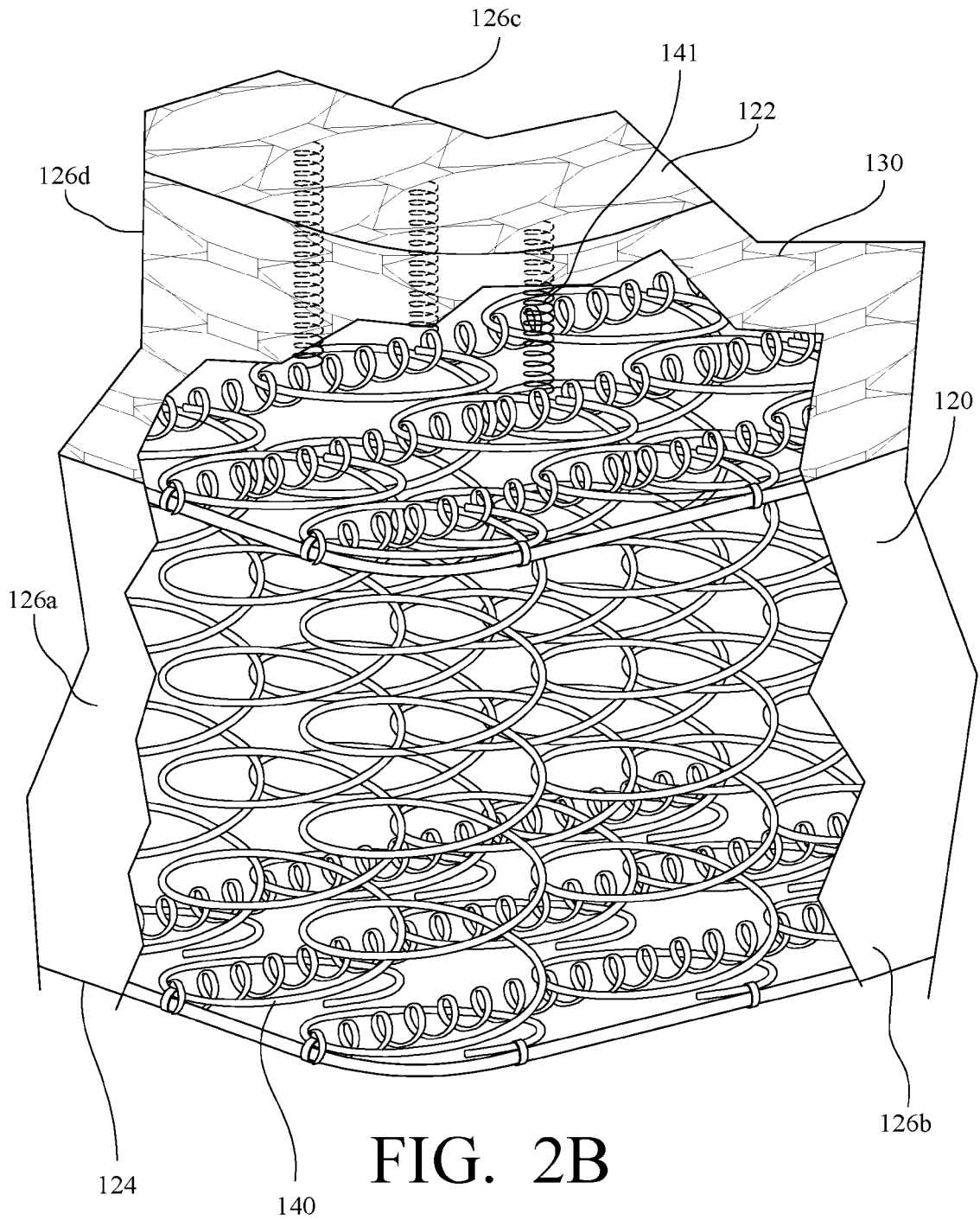

FIG. 2B

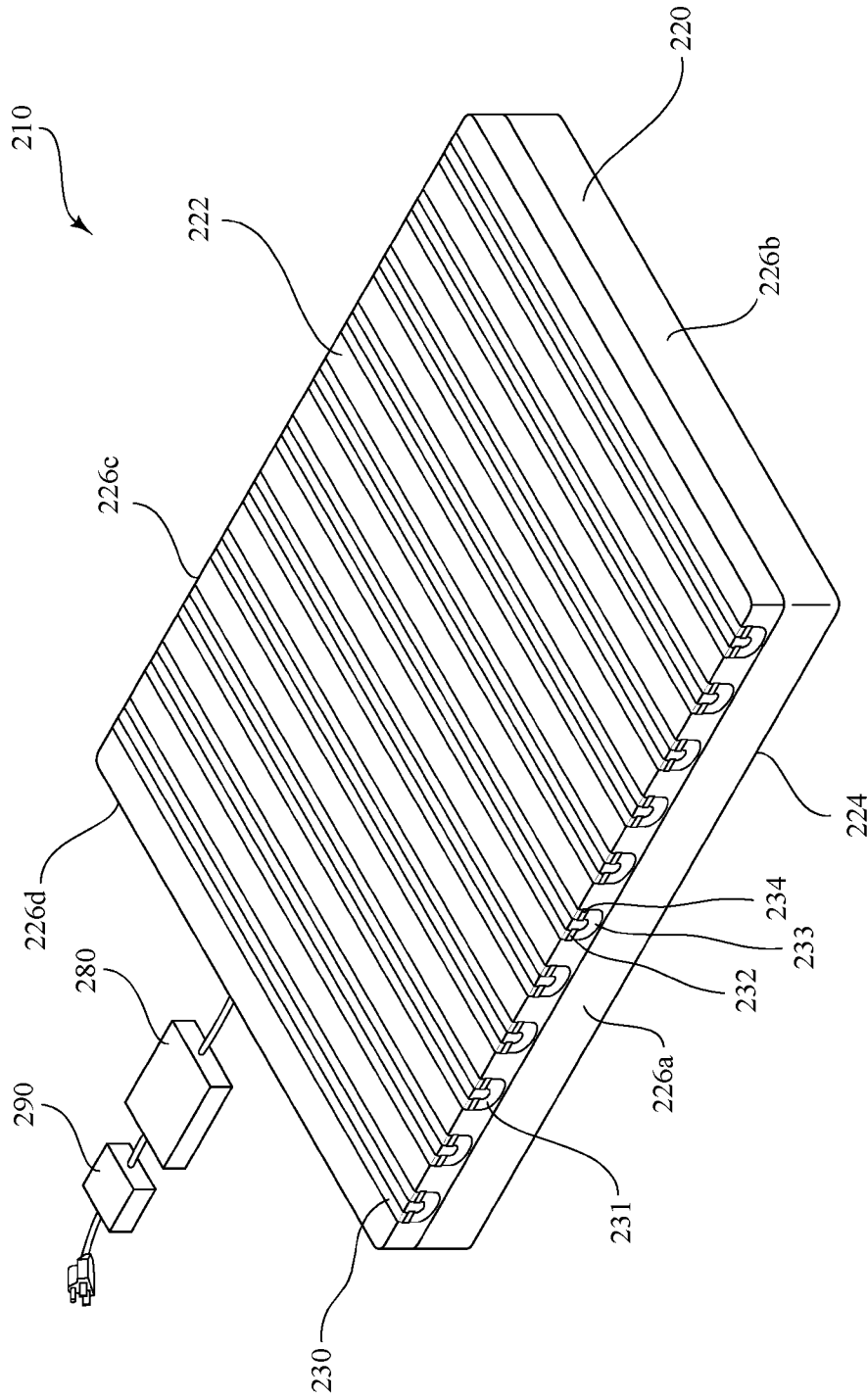

FIG. 3

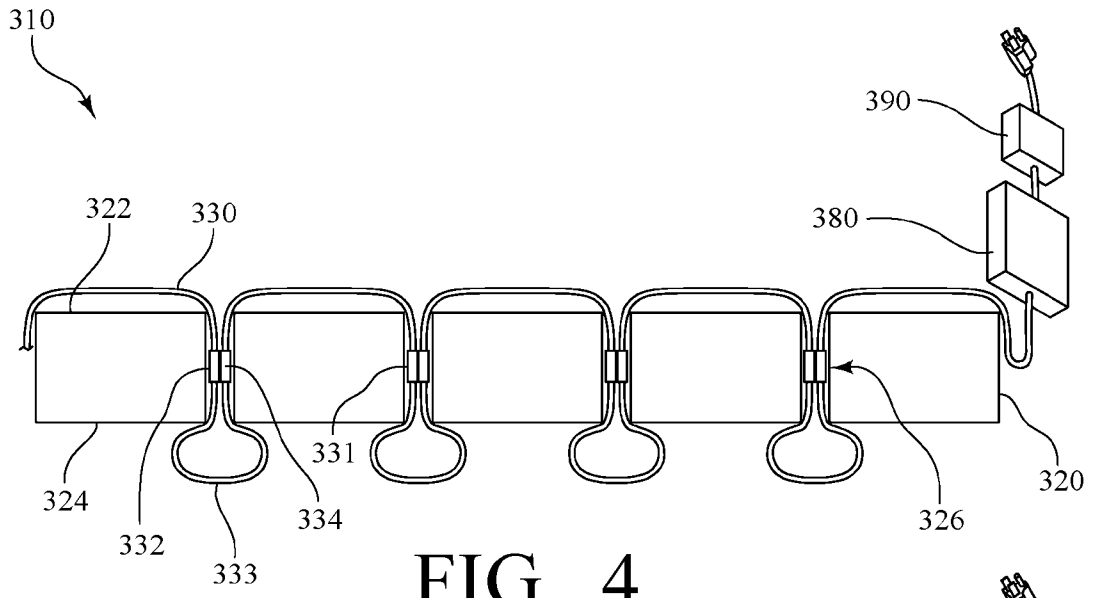

FIG. 4

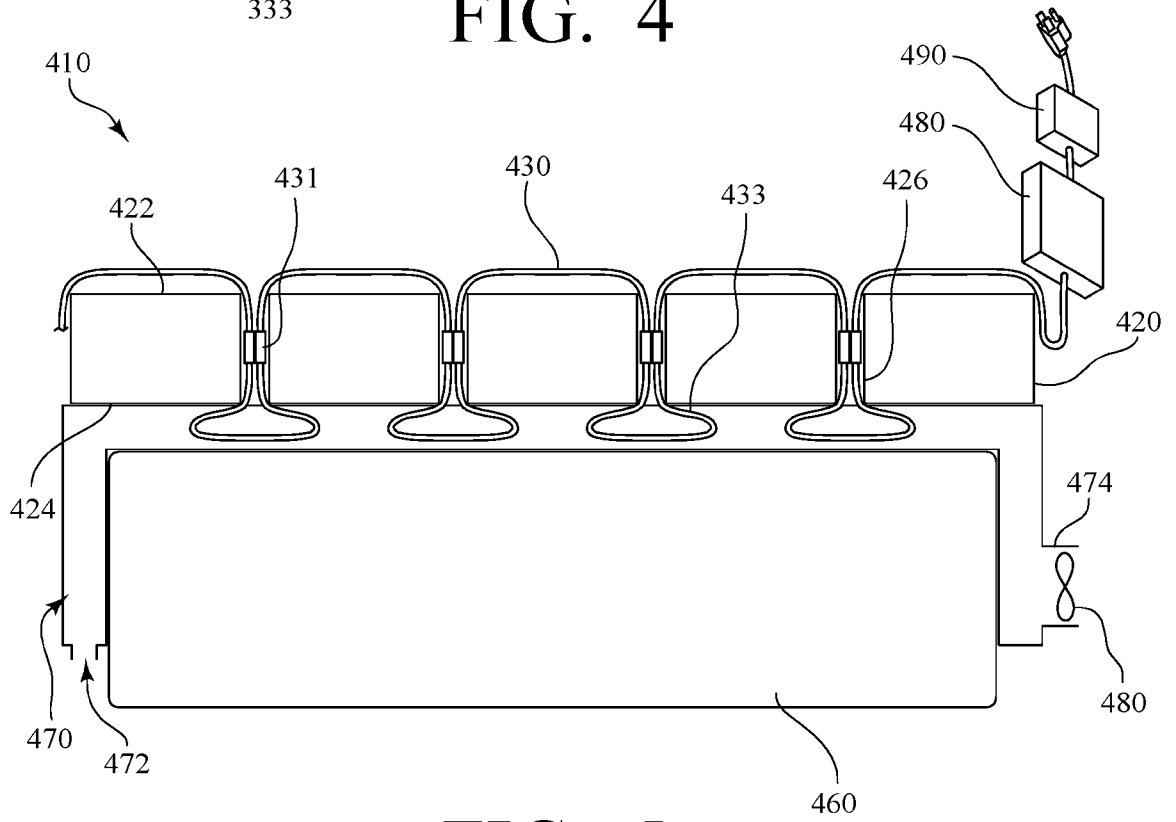

FIG. 5