

No. 678,276.

Patented July 9, 1901.

H. E. POOLE.
SWITCH OPERATING MECHANISM.

(Application filed Feb. 14, 1901.)

(No Model.)

2 Sheets—Sheet 1.

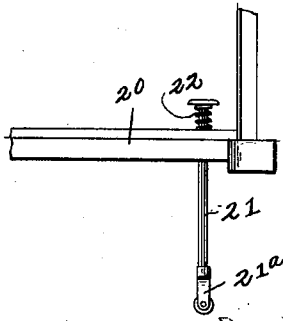
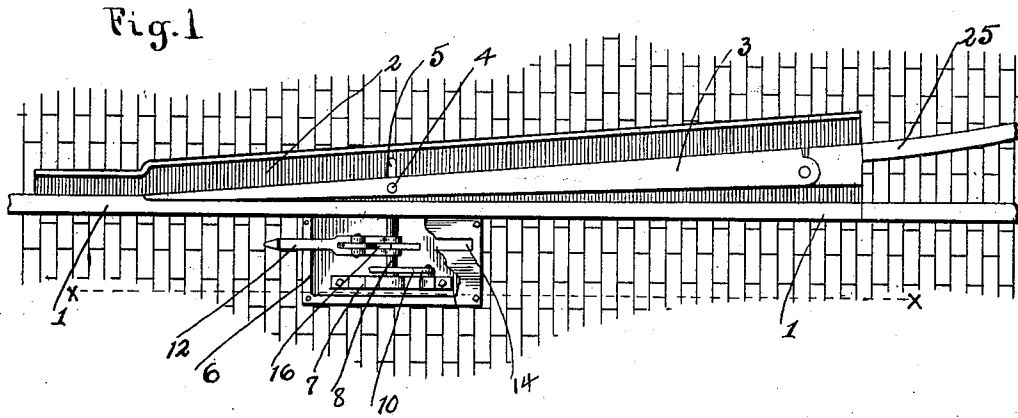

Fig. 2.

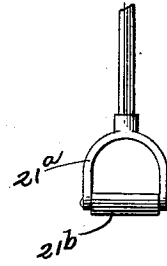

Fig. 3.

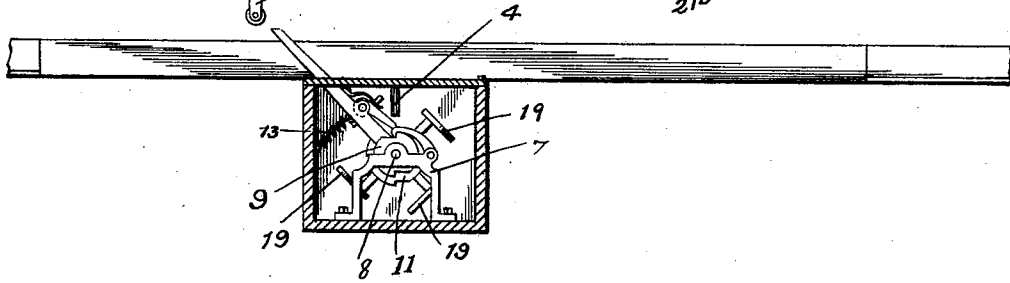

Fig. 4.

WITNESSES:

H. B. Bradshaw
J. W. Fravel

INVENTOR

Harvey E. Poole
BY
C. Shepherd
ATTORNEY

H. E. POOLE.
SWITCH OPERATING MECHANISM.

(Application filed Feb. 14, 1901.)

(No Model.)

2 Sheets—Sheet 2.

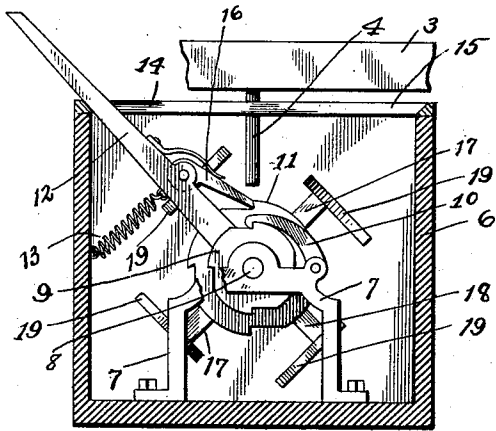

Fig. 5.

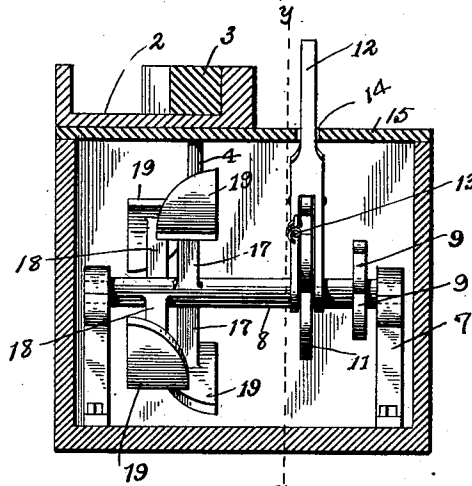

Fig. 6.

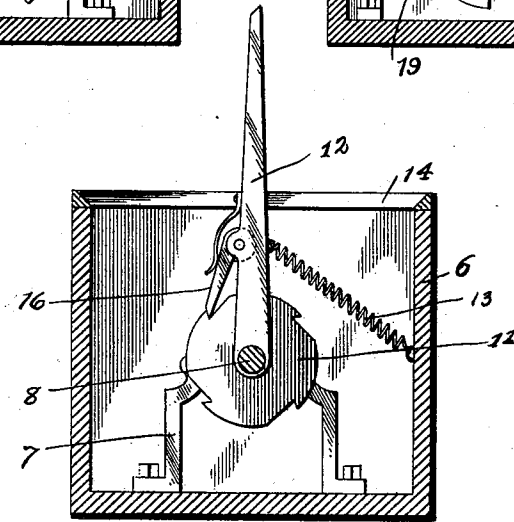

Fig. 7.

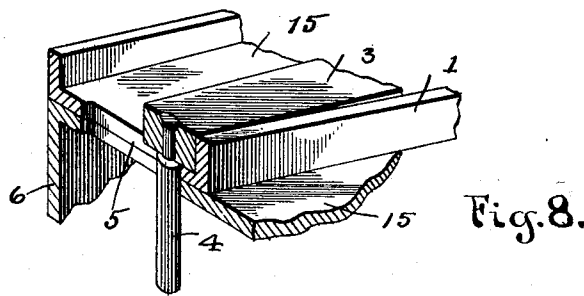

Fig. 8.

WITNESSES:

H. B. Bradshaw
A. L. Phelps

INVENTOR

Harvey E. Poole

BY

C. C. Shepherd

ATTORNEY

UNITED STATES PATENT OFFICE.

HARVEY E. POOLE, OF COLUMBUS, OHIO.

SWITCH-OPERATING MECHANISM.

SPECIFICATION forming part of Letters Patent No. 678,276, dated July 9, 1901.

Application filed February 14, 1901. Serial No. 47,285. (No model.)

To all whom it may concern:

Be it known that I, HARVEY E. POOLE, a citizen of the United States, residing at Columbus, in the county of Franklin and State of Ohio, have invented a certain new and useful Improvement in Switch-Operating Mechanism, of which the following is a specification.

My invention relates to the improvement of switch-operating mechanism for street-railways; and the objects of my invention are to provide a mechanism whereby a switch-tongue may be thrown from a moving car and to produce certain improvements in details of construction and arrangements of parts, which will be more fully pointed out hereinafter. These objects I accomplish in the manner illustrated in the accompanying drawings, in which—

Figure 1 is a plan view of a portion of a street-railway, showing my improvement in connection therewith, the cover-plate of the operating mechanism being broken away for the sake of clearness in illustration. Fig. 2 is a sectional view on line *xx* of Fig. 1. Fig. 3 is a view in elevation of the lower end of the contact-rod which depends from the car. Fig. 4 is a view in perspective of the upper end portion of the operating-lever. Fig. 5 is a side elevation of the operating mechanism, showing a portion of the switch-tongue. Fig. 6 is a view at right angles with that shown in Fig. 5. Fig. 7 is a sectional view on line *yy* of Fig. 6, showing the operating-lever in its vertical position; and Fig. 8 is a detail view, partly in perspective and partly in section, showing a portion of the switch-tongue and its depending pin.

Similar numerals refer to similar parts throughout the several views.

1 represents one of the outer rails of a railway-track, on the inner side of which is provided the usual channeled switch-tongue-supporting plate 2. Upon this switch-tongue plate is pivoted within its wider end in the usual manner the rear end of a switch-tongue 3, this tongue being provided in its forward portion with a downwardly-extending pin 4, which passes through a transverse slotted opening 5 in the plate 2 and depends within an excavation beneath said plate 2, said excavation extending, as shown, on the outer side of the track-rail. Within the pit or ex-

cavation thus formed is supported a suitable casing or framework 6, and within the latter is journaled horizontally in suitable standards 7 a shaft 8. On the outer portion of this shaft and adjacent to one of the standards 7 is carried a comparatively small ratchet-wheel 9, bearing upon the periphery of which is the toothed end of a curved pawl 10, one end of which is pivoted to the adjoining standard 7. On the inner side of the wheel 9 I provide a larger ratchet-wheel 11, which is also fixed on the shaft 8. Loosely embracing the wheel 11 and loose on the shaft 8 are the arms of a bifurcated operating-lever 12, which through the medium of a spring 13 is connected with the inner side of the casing 6 and normally retained in an inclined position at one end of a longitudinal slot 14, formed in the upper side of a street-plate 15, which covers the casing 6. The operating-lever 12 is provided on its upper side with a pivoted spring-actuated pawl 16, the lower end of which is supported in the path of and adapted to engage successively with the teeth of the ratchet-wheel 11.

In its inner portion the shaft 8 is provided with radially-arranged projecting arms, of which there are preferably four, as shown. These arms consist of outer and inner bars 17 and 18, the arms of each pair extending from opposite sides of the shaft 8 and the arms of one pair extending at right angles with the arms of the other. Upon each of the arms 17 and 18 is mounted a substantially triangular cam-body 19, the longer sides of the angle formed thereby being curved, as indicated in the drawings. As shown, the cam-bodies 19 of the arms of each pair are reversed in their positions. When the switch-tongue is in the position indicated in Fig. 1—that is, adjoining the rail 1—the depending pin 4 of said switch-tongue projects within the path of the curved sides of the inner cams 19. In order to operate my improved switch-throwing mechanism, I provide the platform 20 of a car with a downwardly-extending contact pin or rod 21, which, passing loosely through the floor of the car, has its lower end portion normally elevated above the pin of the operating-lever 12 through the medium of a spring 22, which bears between the head of said pin and the platform-floor. In constructing the con-

tact-pin 24 I preferably form the lower end thereof of the substantially stirrup shape indicated at 21^a and shown more clearly in Fig. 3 of the drawings, and this stirrup termination may be provided in its lower portion with a journaled friction-roller 21^b.

As indicated in Fig. 4 of the drawings, the upper end portion of the operating-lever may in order to more readily deflect the wheels of vehicles be of a substantially triangular form in cross-section.

As shown in Fig. 2 of the drawings, the upper end of the operating-lever normally projects but slightly above the level of the track-rail. In order to illustrate the operation of my device, I will assume that the switch-tongue 3 has its point thrown into connection with the rail 1 in the manner indicated in Fig. 1 of the drawings, in which position said tongue will serve to change the course of the car-wheels from the rail 1 to the switch-rail 25, and I will also assume that it is desired to continue the wheels of the car upon the track-rails 1. As the car approaches the switch the motorman or car-operator depresses the contact-pin 21 until its lower end portion is in position to engage the projecting end of the lever 12 and force the latter over to the opposite side of the casing 6 through the slotted opening 15. Owing to the engagement of the pawl 16 with one of the teeth of the ratchet 11, it is obvious that the shaft 8 will be partially rotated in its bearings, together with the radial arms 17 and 18. This movement of said arms 17 results in the curved face or edge of one of the cam-heads 19 coming into contact with the outer side of the switch-tongue pin 4 and in the latter being forced inwardly until the switch-tongue is out of contact with the rail 1, thus providing a clear track for the coming car-wheels. As the lower

end of the contact-rod 21 loses its engagement with the operating-lever it is obvious that the spring 13 will operate to immediately return said operating-lever to its normal position. In this latter operation the shaft will be prevented from reversed rotation through the slipping of the pawl 16 over the teeth of the wheel 11 and the engagement of the pawl 10 with a tooth of the wheel 9. It being desired by the operator of the next succeeding car moving in the same direction to run onto the switch-rail, the operating-lever is thrown in the manner above described, with the result that one of the cams 19 of one of the shaft-arms 18 has its curved edge brought into contact with the switch-tongue pin and the latter is forced toward the rail.

From the construction and operation described it will be seen that simple and reliable means are provided for throwing the switch-tongue of a railway-switch and that the parts are so arranged and constructed as to insure a positive operation thereof.

Having now fully described my invention, what I claim, and desire to secure by Letters Patent, is—

In a switch-operating mechanism, the combination with railway-track rails, a pivoted switch-tongue and a depending tongue-pin, of a shaft journaled beneath the trackway, inner and outer sets of arms on said shaft, cam-heads on said arms each having a curved edge portion and a lever extending from said shaft and adapted to contact with a projection from a car-platform, substantially as specified.

HARVEY E. POOLE.

In presence of—

C. C. SHEPHERD,
W. L. MORROW.