



Europäisches Patentamt
European Patent Office
Office européen des brevets



(11)

EP 1 347 085 B1

(12)

EUROPEAN PATENT SPECIFICATION

(45) Date of publication and mention
of the grant of the patent:
25.10.2006 Bulletin 2006/43

(51) Int Cl.:
D01H 4/48^(2006.01) D01H 4/02^(2006.01)

(21) Application number: **03005279.9**

(22) Date of filing: **10.03.2003**

(54) **Vortex spinning method and apparatus**

Vortex Spinnverfahren und Spinnmaschine

Méthode et dispositif de filature vortex

(84) Designated Contracting States:
CH DE LI

(30) Priority: **18.03.2002 JP 2002073711**

(43) Date of publication of application:
24.09.2003 Bulletin 2003/39

(73) Proprietor: **MURATA KIKAI KABUSHIKI KAISHA**
Minami-ku
Kyoto-shi
Kyoto 601 (JP)

(72) Inventors:
• **Baba, Kenji**
Kyoto-shi,
Kyoto (JP)
• **Shigeyama, Masazumi**
Shiga-gun,
Shiga (JP)

(74) Representative: **Liedl, Christine et al**
c/o Hansmann & Vogeser,
Albert-Rosshaupter-Strasse 65
81369 München (DE)

(56) References cited:
EP-A- 1 072 702 **US-A- 5 022 123**

EP 1 347 085 B1

Note: Within nine months from the publication of the mention of the grant of the European patent, any person may give notice to the European Patent Office of opposition to the European patent granted. Notice of opposition shall be filed in a written reasoned statement. It shall not be deemed to have been filed until the opposition fee has been paid. (Art. 99(1) European Patent Convention).

Description

Field of the Invention

[0001] The present invention relates to a spinning method and apparatus which manufactures a spun yarn by allowing a whirling air current to act on a bundle of fibers drafted by a draft device to twist the fibers.

Background of the Invention

[0002] A conventional spinning method and apparatus is known (The Unexamined Japanese Patent Application Publication (Tokkai-Hei) No. 2001-40532). According to this method and apparatus, simply by supplying a bundle of fibers drafted by a draft device to a spinning member composed of a nozzle member generating a whirling air current, a hollow guide shaft, and the like without inserting a yarn called a "seed yarn" or a "leading yarn" through the spinning member, a yarn is generated and discharged (yarn discharging spinning, described later) using the nozzle member of the spinning member and an auxiliary nozzle formed in the hollow guide shaft. Subsequently, a yarn joining device joins together the yarn generated by the spinning member and a yarn connected to a winding package to allow spinning to be started or allow spinning to be resumed after yarn breakage.

[0003] In the above described conventional spinning method and apparatus, to enhance the reliability of the yarn discharging spinning, i.e. the resumption of spinning after yarn breakage, it is necessary to allow air currents from the nozzle member and the auxiliary nozzle to sufficiently and reliably act on a bundle of fibers during the yarn discharging spinning. The spinning speed of the spinning apparatus used during the yarn discharging spinning carried out during a spinning resuming operation after yarn breakage or at the start of spinning is set taking the above point into account. Thus, disadvantageously, a normal spinning speed is limited by the spinning speed of the yarn discharging spinning. This prevents the spinning speed of the spinning apparatus from being increased.

Summary of the Invention

[0004] It is an object of the present invention to solve the problems of the above described conventional spinning method and apparatus. To accomplish this object, the present invention has the features described below.

[0005] In a spinning method of drafting supplied fibers at a predetermined total draft ratio and then spinning the fibers using a spinning member composed of a nozzle member having a nozzle hole, first, before yarn discharging spinning, the amount of fibers supplied to the spinning member per unit time in a normal spinning state is changed to the amount of fibers supplied per unit time during the yarn discharging spinning, the latter amount being different from the former amount, and after the yarn

discharging spinning has ended, the changed amount of fibers supplied is returned to the amount of fibers supplied in the normal spinning state.

[0006] Second, a yarn feeding device is provided which exerts feeding force on a yarn spun out by the spinning member, and on the basis of a timing with which the yarn feeding device starts exerting yarn feeding force, the changed amount of fibers supplied is returned to the amount of fibers supplied in the normal spinning state.

[0007] Third, the amount of fibers supplied can be changed by changing, before the yarn discharging spinning, the total draft ratio to one different from the total draft ratio used in the normal spinning state, and returning the changed total draft ratio to the total draft ratio used in the normal spinning state, after the yarn discharging spinning has ended.

[0008] Fourth, the spinning member is composed of a nozzle member having a nozzle hole and a hollow guide shaft, and for a yarn joining operation, the yarn discharging spinning is carried out by injecting a whirling air current from the nozzle member and injecting compressed air from an auxiliary nozzle formed in the hollow guide shaft, into a yarn passage to generate suction force directed from an opening formed in a tip of the hollow guide shaft, toward a yarn discharge port.

[0009] Further, in a spinning apparatus comprising a draft device which drafts supplied fibers and a spinning member composed of a nozzle member, first, the apparatus further comprises a draft device which drafts supplied fibers and fiber supply amount control means which can operate to switch the amount of fibers per unit time supplied to the spinning member by the draft device in a normal spinning state, to the amount of fibers supplied to the spinning member by the draft device during yarn discharging spinning and normal spinning state.

[0010] Second, the spinning apparatus further comprises a yarn feeding device which exerts feeding force on a yarn spun out by the spinning member, and the controls means provides such control that the changed amount of fibers supplied is returned to the amount of fibers supplied in the normal spinning state, on the basis of a timing with which the yarn feeding device starts exerting yarn feeding force.

[0011] Third, the control means is total draft ratio change control means which can change a total draft ratio of the draft device used in a normal spinning state to one for yarn discharging spinning.

[0012] Fourth, the spinning apparatus comprises a plurality of spinning units arranged in line and each comprising the draft device and spinning member, and the draft device is composed of a plurality of draft rollers rotating at different rotation speeds, and at least one of the plurality of rollers can be controlled to rotate at one of different speeds corresponding to the respective spinning units. Fifth, the roller that can be controlled to rotate at one of the different speeds corresponding to the respective spinning units is different from a front roller. Sixth, the at least one of the plurality of rollers is driven

by a motor that drives a corresponding one of the spinning units, and control means is disposed which controls the rotation speed of the motor for each spinning unit. Seventh, the motor is a stepping motor. Eighth, the spinning member is composed of a nozzle member and a hollow guide shaft, and an auxiliary nozzle is provided which injects, during yarn discharging spinning, compressed air into a passage in the hollow guide shaft to generate suction force directed from an opening formed in a tip of the hollow guide shaft, toward a yarn discharge port.

Brief Description of the Drawings

[0013]

Figure 1 is a perspective view of a spinning unit constituting a spinning apparatus according to the present invention.

Figure 2 is a schematic front view of the spinning apparatus and a yarn joining carriage according to the present invention.

Figure 3 is a side sectional view of a spinning member constituting the spinning apparatus according to the present invention.

Figure 4 is a schematic side view including a control block and other components of the spinning apparatus according to the present invention.

Figure 5 is a graph showing the relationship between the rotation speed of individual-spindle-driving motor and time during a joining operation.

Detailed Description of the Preferred Embodiments

[0014] An embodiment of the present invention will be described below. However, the present invention is not limited to the present embodiment but other embodiments are possible unless they deviate from the spirits of the present invention.

[0015] First, with reference to Figures 1 and 2, brief description will be given of a spinning unit constituting a spinning apparatus according to the present invention.

[0016] 1 is a bundle of fibers accommodated in a can 2. (D) is a 4-line draft device taken by way of example and composed of a plurality of draft rollers including a back roller 3, a third roller 4, a second roller 5 around which an apron belt 5a is installed, and a front roller 6. (S) is a spinning member described later. 7 is a yarn feeding member composed of a nip roller 7a and a delivery roller 7b. 8 is a slack tube in which a yarn discharged from the spinning member (S) that has resumed spinning is reserved. 9 is a yarn clearer.

[0017] 10 is a package wound around a bobbin 12 supported by a bobbin holder 11. The package 10 is configured so as to be rotated by having a friction roller 13 abutting against its surface. 14 is a traversing guide of a traversing device (not shown in the drawings). A winding member (W) is constituted by the bobbin 12 supported by the bobbin holder 11, the friction roller 13, the travers-

ing guide 14, and others.

[0018] The bundle of fibers 1 drawn out from the can 2 via a guide bar 15 is drafted by the draft device (D) and then enters the spinning member (S). The spinning member (S) then forms the fibers into a yarn. The yarn Y discharged by the spinning member (S) is fed toward the package 10 while being sandwiched between the nip roller 7a and the delivery roller 7b, constituting the yarn feeding member 7. Then, while being traversed by the traversing guide 14, the yarn Y is wound around the package 10 which abuts against the friction roller 13 and is rotating.

[0019] A spinning apparatus is composed of a large number of spinning units (U) arranged in line along a frame (F), the spinning units (U) each being composed of the draft device (D), the spinning device (S), the yarn feeding member 7, the slack tube 8, the yarn clearer 9, the winding member (W), and others as described above.

[0020] As shown in Figure 2, E1 is a motor box disposed at one end of the spinning apparatus, and E2 is a blower box disposed at the other end of the spinning apparatus. (A) is a yarn joining carriage configured to run on a rail (R) disposed along a longitudinal direction of the spinning apparatus. On the yarn joining carriage (A) are disposed a well-known suction nozzle (a1) as spinning member side yarn capturing means, a well-known yarn joining device (a2) such as a knotter or a splicer, a well-known suction mouth (a3) as package side yarn capturing means, and the like.

[0021] Now, the spinning member will be described with reference to Figure 3.

[0022] As shown in Figure 3, 16 is a fiber introducing block having an introduction port 16a into which the bundle of fibers 1 drafted by the draft device (D) and a needle 16b disposed on a channel for the bundle of fibers 1. The fiber introducing block 16 is fitted into an attaching hole 17a formed in a tip of the nozzle member 17. A substantially-cone-frustum-shaped space portion 17c having an inner peripheral wall 17b inclined to so as to diverge away from the fiber introducing block 16 is formed downstream of the attaching hole 17a, into which the fiber introducing block 16 has been fitted. 17d is a plurality of nozzle holes formed in the nozzle member 17 and located close to the fiber introducing block 16. 17e is a compressed air supply member in which an air passage 17e1 is formed so as to surround the nozzle holes 17d. The compressed air supply member 17e is connected to a compressed air supply source (not shown in the drawings).

[0023] 17f is a suction hole formed in a cylindrical portion 17g of the nozzle member 17. A pipe 18 connected to an air suction source (not shown in the drawings) is connected to the suction hole 17g.

[0024] 19 is a hollow guide shaft. The hollow guide shaft 19 has a cone-frustum-shaped tip portion 19a and a cylindrical portion 19c having an annular internal air passage 19b. A yarn passage 19d is formed along the axis of the hollow guide shaft 19. The internal air passage 19b and the yarn passage 19d are connected together via an auxiliary nozzle 19e. Further, a pipe 21 connected

to a compressed air supply source (not shown in the drawings) is connected to the internal air passage 19b via a connecting member 20 connected to a through-hole 19f formed in the cylindrical portion 19c. The auxiliary nozzle 19e is configured to lie closer to the tip portion 19a than the through-hole 19f formed in the cylindrical portion 19c. Compressed air from the compressed air supply source enters the internal air passage 19b via the connecting member 20 and the pipe 21. Subsequently, the compressed air is injected from the auxiliary nozzle 19e and enters the yarn passage 19d formed in the hollow guide shaft 19. The air then flows toward a yarn discharge port 19g located opposite the tip portion 19a of the hollow guide shaft 19.

[0025] The hollow guide shaft 19 is fitted into an attaching hole 22a formed in a shaft attaching member 22. The shaft attaching member 22 is configured to be merged with the nozzle member 17 by fitting its fitting portion 22b into the cylindrical portion 17g of the nozzle member 17. Further, the cone-frustum-shaped tip portion 19a of the hollow guide shaft 19 is arranged in the substantially-cone-frustum-shaped space portion 17c. The tip portion 19a is also arranged opposite the needle 16b attached to the fiber introducing block 16.

[0026] Now, brief description will be given of a process of generating the yarn Y using the spinning unit constituting the spinning apparatus configured as described above.

[0027] The bundle of fibers 1 is drawn out from the can 2 and then supplied to the draft device (D). The bundle of fibers 1 is then drafted at a predetermined total draft ratio by the draft device (D). Then, the bundle of fibers 1 is introduced into the introducing hole 16a of the fiber introducing block 16 by a sucking air current generated near the introducing hole 16a owing to the action of air injected from the nozzle hole 17d in the nozzle member 17. Subsequently, the bundle of fibers 1 is fed along the periphery of the needle 16b and enter a spinning chamber 17c1 located in the space portion 17c, formed in the nozzle member 17, and between the tip portion 19a of the hollow guide shaft 19 and the fiber introducing block 16.

[0028] The fibers constituting the bundle of fibers 1 sucked into the spinning chamber 17c1 undergo the action of a whirling air current injected from the nozzle hole 17d and whirling near the tip portion 19a of the hollow guide shaft 19. While being separated from the bundle of fibers 1, some of the fibers are reversed and wrapped around the outer periphery of tip portion 19a of the hollow guide shaft 19. Furthermore, the fibers are swung around the yarn Y being generated and is wrapped its outer periphery. The fibers are thus twisted in the direction of the whirling air current. Further, part of the twist applied by the whirling air current attempts to propagate toward the front roller 6. However, the needle 16b hinders the propagation to prevent the bundle of fibers 1 fed from the front roller 6 from being twisted by this twist. The fibers twisted by the whirling air current are sequentially formed into the truly twisted-like yarn Y, composed of a core fiber

and a wrapping fiber wound around the core fiber. Then, the yarn Y passes through the yarn passage 19d in the hollow guide shaft 19 and is then discharged from the yarn discharge port 19g. During such a normal process of generating the yarn Y, compressed air from the compressed air supply source is not supplied to the internal air passage 19b in the hollow guide shaft 19 via the pipe 21 and the connecting member 20. Consequently, the feeding of compressed air from the auxiliary nozzle 19e into the yarn passage 19d is not carried out.

[0029] In a normal spinning state, the yarn Y passes through the yarn passage 19d in the hollow guide shaft 19 and then exits the yarn discharge port 19g. The yarn Y is then fed toward the package 10 while being sandwiched between the nip roller 7a and delivery roller 7b, constituting the yarn feeding member 7. Subsequently, while being traversed by the traversing guide 14, the yarn Y is thus wound around the package 10, which abuts against the friction rollers 13 and is rotating.

[0030] Now, description will be given of a yarn joining operation performed by the spinning apparatus configured as described above.

[0031] At the start of spinning or when the yarn is broken, the back roller 3 and the third roller 4 are stopped.

Accordingly, the bundle of fibers 1 is cut between the stopped third roller 4 and the second roller 5, which is always rotated. The tip portion of the bundle of fibers 1 is gripped by the stopped third roller 4. For a yarn joining operation, the back roller 3 and the third roller 4 are re-driven to feed out the bundle of fibers 1. The bundle of fibers 1 is also supplied to the spinning member (S) via the second roller 5 and front roller 6, which are always rotationally driven. Simultaneously with the resumption of driving of the draft device (D), which has been stopped, compressed air starts to be injected from the nozzle hole 17d in the nozzle member 17 and from the auxiliary nozzle 19e in the hollow guide shaft 19. That is, during a yarn joining operation, compressed air is injected from the nozzle hole 17d in the nozzle member 17, while compressed air from the compressed air supply source is supplied to the internal air passage 19b in the hollow guide shaft 19 via the pipe 21 and the connecting member 20. Consequently, compressed air is also injected from the auxiliary nozzle 19e into the passage 19d.

[0032] While whirling, the compressed air injected from the nozzle hole 17d in the nozzle member 17 flows in the direction in which the bundle of fibers 1 is fed.

[0033] Thus, the bundle of fibers 1 introduced into the introducing hole 16a in the fiber introducing block 16 is fed to the neighborhood of the tip portion 19a of the hollow guide shaft 19 via the needle 16b, while being loosely falsely twisted by the whirling air current. Further, the compressed air injected from the auxiliary nozzle 19e flows along the yarn passage 19d formed in the hollow guide shaft 19, while forming a whirling air current. This compressed air also generates an air flow near an opening 19h formed in the tip portion 19a of the hollow guide shaft 19, the air flow flowing in a suction direction (toward

the interior of the hollow guide shaft 19). Thus, the bundle of fibers 1 can be continuously drawn into the yarn passage 19d in the hollow guide shaft 19.

[0034] The falsely twisted bundle of fibers 1 fed to the neighborhood of the opening 19h formed in the tip portion 19a of the hollow guide shaft 19, is sucked into the yarn passage 19d through the opening 19h. Then, in the yarn passage 19d, the bundle of fibers 1 is exposed to the whirling air current generated by the compressed air injected from the auxiliary nozzle 19e. The loosely falsely twisted bundle of fibers 1 is spun into a fasciated-fibers-like yarn (fasciated yarn) by the whirling air current generated in the spinning chamber 17c1 by the compressed air injected from the nozzle hole 17d in the nozzle member 17 as well as the whirling air current generated in the yarn chamber 19d in the hollow guide shaft 19 by the compressed air injected from the auxiliary nozzle 19e in the hollow guide shaft 19. At the same time, the yarn is discharged from the yarn discharge port 19g in the hollow guide shaft 19.

[0035] The term "yarn discharging spinning" refers to the state in which after yarn breakage, the back roller 3 and the third roller 4 are re-driven to restart feeding the bundle of fibers 1 to spin a fasciated-fibers-like yarn using the compressed air injected from the nozzle hole 17d in the nozzle member 17 as well as the compressed air injected from the auxiliary nozzle 19e formed in the hollow guide shaft 19, as described above.

[0036] Once an appropriate time has passed after the above described yarn discharging spinning, the compressed air stops being fed from the compressed air supply source to the internal air passage 19b in the hollow guide shaft 19, and the compressed air stops being injected from the auxiliary nozzle 19e into the yarn passage 19d. Then, the whirling air current in the hollow guide shaft 19 disappears to bring the apparatus into a normal spinning state.

[0037] Spinning of the yarn Y is resumed as described above. The yarn Y is sucked into the well-known suction nozzle (a1), which is disposed in the yarn joining carriage (A) stopped at the position of the spinning unit U that is to perform a yarn joining operation and is rotationally movable to the neighborhood of the yarn discharge port 19g in the hollow guide shaft 19, by its upward rotational movement. Subsequently, as the suction nozzle (a1) rotationally moves downward, the yarn Y is introduced into the well-known yarn joining device (a2), disposed in the yarn joining carriage (A). While being guided toward the yarn joining device (a2) by the suction nozzle (a1), the yarn Y is sandwiched between the nip roller 7a and the delivery roller 7b, constituting the yarn feeding member 7. On the other hand, the terminal portion of the yarn Y wound around the package 10 is sucked into the well-known suction mouth (a3), disposed in the yarn joining carriage (A). Subsequently, as the suction mouth (a3) rotationally moves upward, the terminal portion of the yarn Y is introduced into the yarn joining device (a2). Then, the yarn Y generated by the spinning member (S)

and the yarn Y drawn out from the package 10 are both introduced into the yarn joining device (a2). The yarn joining device (a2) is then driven to join both yarns Y to complete the yarn joining operation. The extra yarn Y generated during the yarn joining operation is reserved in the slack tube 8.

[0038] Now, with reference to Figures 2 and 4, description will be given of operations and driving control of the draft device (D), spinning member (S), yarn feeding member 7, yarn clearer 9, and winding member (W), and others.

[0039] M1 is a individual-spindle-driving motor arranged for each spinning unit U to drive the back roller 3 and the third roller 4. The back roller 3 and the third roller 4 are rotationally driven using an endless belt (b1) extended between a pulley 3a attached to the back roller 3 and a pulley 4a attached to the third roller 4 and a pulley (m1) attached to an output shaft of the individual-spindle-driving motor M1. The individual-spindle-driving motor M1 is configured to have its rotation speed controlled by a central control device C1 as a higher controller via a motor driver MD1. In this case, the individual-spindle-driving motor M1 may be a stepping motor. This eliminates the need for a rotation detector such as an encoder to enable control using an open loop.

[0040] M2 is a common motor that rotationally drives the second roller 5 via a transmission T1 and that rotationally drives the front roller 6, the delivery roller 7b, constituting the yarn feeding member 7, and the friction roller 13. This single common motor M2 is disposed in the motor box E1 and shared by the plurality of spinning units U, constituting the spinning apparatus. The common motor M2 is configured to be controlled, via a motor driver MD2, by a central control device C2 as a higher controller disposed in the motor box E1. Then, if the common motor M2 is accelerated or decelerated via the motor driver MD2 according to a command from the central control device C2, the second roller 5, the front roller 6, the yarn feeding member 7, and the friction roller 13 are controlled to synchronize with one another while maintaining a predetermined rotation speed ratio. Since the back roller 3, the third roller 4, the second roller 5, and the front roller 6 rotate at different rotation speeds, it is possible to perform a drafting operation at a predetermined total draft ratio.

[0041] The thickness (yarn count) of the yarn generated depends mainly on the amount of fibers discharged from the front roller 6 and supplied to the spinning member (S). With the conventional spinning apparatus, even during a yarn joining operation in the spinning apparatus, the same amount of fibers as that used for the normal yarn generating operation is supplied to the spinning member (S) by the draft device (D).

[0042] However, if an inappropriate amount of fibers are supplied during yarn discharging spinning for a yarn joining operation, the yarn discharging spinning may fail. For example, it is assumed that yarn breakage occurs while a spun yarn Y of a smaller yarn count is being gen-

erated. Then, when the above described yarn discharging spinning is carried out by supplying the spinning member (S) with the same amount of fibers as that used for a normal operation of generating a yarn of a smaller yarn count, the amount of fibers is small and insufficient to bundle the fibers in generating a fasciated yarn for the yarn spinning discharging. Thus, the yarn generation for the yarn discharging spinning may fail. For example, if the yarn discharging spinning is carried out at high speed, the fibers are not sufficiently bundled because they are exposed to a whirling air current only a short time and for the above described reason.

[0043] Consequently, the yarn generated is not strong enough to endure being spun out downward. In contrast, it is assumed that yarn breakage occurs while a spun yarn of a larger yarn count is being generated. Then, when the above described yarn discharging spinning is carried out by supplying the spinning member (S) with the same amount of fibers as that used for a normal operation of generating a yarn of a larger yarn count, the amount of fibers so large that the opening 19h in the hollow guide shaft 19 of the spinning member (S) may be filled with the fibers. Thus, the yarn generation for the yarn discharging spinning may fail.

[0044] Referring mainly to Figure 4 and Figure 5, showing the relationship between the rotation speed of the individual-spindle-driving motor M1 and time during a yarn joining operation, description will be given of a yarn joining operation according to an embodiment of the present invention which operation improves the success rate of the above described yarn discharging spinning.

[0045] If the yarn Y generated has a defective part such as a thicker portion such as a slab or a thinner portion, the defective portion is detected by the yarn clearer 9. The yarn Y the defective portion of which has been detected is cut by the cutter. A part of the cut yarn Y which is connected to the package 10 is wound around the package 10. A yarn defective-part detection signal from the yarn clearer 9 is inputted to the central control device C1 as shown in Figure 4. On the basis of this yarn defective-part detection signal, the central control device C1 stops driving of the individual-spindle-driving motor M1 via the motor driver MD1. Then, the back roller 3 and the third roller 4 stops rotating to cut the bundle of yarns 1 between the second roller 5, which are always rotated, and the third roller 4 (time T1 in Figure 5). The bundle of fibers 1 fed out from the second roller 5 and the front roller 6, which are always rotated, is supplied to the spinning member (S), which is still being driven. The bundle of fibers 1 is then formed into a yarn Y. The yarn Y generated is sucked into a duct (not shown in the drawings) for removal, the duct being located immediately upstream of the cutter. Subsequently, compressed air stops being injected from the nozzle hole 17d formed in the nozzle member 17, constituting the spinning member (S), to stop the operation of the spinning member (S). Further, the package 10 is separated from the friction roller 13 to stop rotating.

[0046] Subsequently, the above described yarn discharging spinning is carried out. However, for example, if yarn breakage occurs while a spun yarn Y of a smaller yarn count is being generated, when the above described yarn discharging spinning is carried out by supplying the spinning member (S) with the same amount of fibers as that used for a normal operation of generating a yarn of a smaller yarn count, the yarn discharging spinning may fail because of the small amount of fibers. Accordingly, in the present embodiment, in resuming the spinning process, the central control device C1 increases the rotation speed of the individual-spindle-driving motor M1, which rotationally drives the back roller 3 and the third roller 4, via the motor driver MD1 compared to the normal spinning. This reduces the total draft ratio and increase the amount of fibers supplied to the spinning member (S). This is because during the normal spinning, the second roller 5 rotates faster than the back roller 3 and the third roller 4 and because during the normal spinning, the front roller 6 rotates faster than the second roller 5. In particular, the difference in rotation speed between the second roller 5 and the front roller 6 is set to be larger than the other differences.

[0047] According to a command from the central control device C1, the back roller 3 and the third roller 4 are re-driven to feed out the bundle of fibers 1, the tip of which is gripped by the third roller 4, which is stopped (time T2 in Figure 5). Further, as described above, according to a command from the central control device C1, the back roller 3 and the third roller 4 are rotated faster than in the normal spinning state to reduce the total draft ratio of the draft device (D). Thus, fibers the amount of which is larger than that used for the normal yarn generating process are supplied to the spinning member (S) via the second roller 5 and the front roller 6 (time T3 in Figure 5). Substantially simultaneously with the resumption of driving of the draft device (D), which has been stopped, compression air restarts to be injected from the nozzle hole 17d formed in the nozzle member 17, constituting the spinning member (S). Further, compressed air is injected from the auxiliary nozzle 19e formed in the hollow guide shaft 19. Thus, yarn discharging spinning is carried out as described above. As a result, the central control device C1 operates as fiber supply amount control means and total draft ratio change control means for switching the amount of fibers supplied per unit time and the total draft ratio, respectively, between the yarn discharging spinning and the normal spinning.

[0048] The yarn Y generated by the yarn discharging spinning is discharged from the yarn discharge port 19g in the hollow guide shaft 19. The yarn Y is sucked into the suction nozzle (a1), which is disposed in the yarn joining carriage (A) and is positioned close to the yarn discharge port 19g, by its upward rotational movement, and the yarn Y is thus captured (time T4 in Figure 5). Subsequently, as the suction nozzle (a1) rotationally moves downward, the yarn Y sucked and captured by the suction nozzle (a1) is introduced into the yarn joining

device (a2), disposed in the yarn joining carriage (A). While being guided toward the yarn joining device (a2) by the suction nozzle (a1), the yarn Y is sandwiched between the nip roller 7a and the delivery roller 7b, constituting the yarn feeding member 7, and the yarn Y then starts being fed and is thus stably fed out (time T5 in Figure 5).

[0049] Further, concurrently with the above described operation performed by the suction nozzle (a1) to introduce the yarn Y into the yarn joining device (a2), a suction port in the suction mouth (a3), also disposed in the yarn joining carriage (A), is moved closer to the package 10 being rotated by a reversing roller (not shown in the drawings) in the direction opposite to a winding direction. The yarn Y wound around the package 10 is thus sucked. Furthermore, the suction mouth (a3) is rotationally moved upward to introduce the yarn Y into the yarn joining device (a2). Then, the yarn Y generated by the spinning member (S) and the yarn Y drawn out from the package 10 are introduced into the yarn joining device (a2). The yarn joining device (a2) is then driven to join both yarns Y to complete the yarn joining operation (time T8 in Figure 5). The extra yarn Y generated during the yarn joining operation is temporarily reserved in the slack tube 8. Further, a thicker portion of the yarn generated on the basis of the changed total draft ratio is disposed of during the yarn joining operation performed by the yarn joining device (a2). Consequently, such a thicker portion is not wound around the package 10.

[0050] Also during the above described yarn discharging spinning, the second roller 5, front roller 6, yarn feeding member 7, and friction roller 13, rotationally driven by the common motor M2, are controlled to synchronize with one another as in the case with the normal spinning process.

[0051] During the above described yarn discharging spinning process, the changed total draft ratio is more preferably returned to the normal total draft ratio after the yarn feeding member 7 as a yarn feeding device has started exerting force for feeding the yarn Y (time T5 in Figure 5), particularly after the yarn discharging spinning has completed (time T6 in Figure 5). As a result, the yarn count is changed after the yarn feeding member 7 has started feeding the yarn stably. Therefore, the end of the spun-out yarn can be more reliably fed out downstream. The yarn discharging spinning is carried out between the above described time T2 and T6. Subsequently, at the time T6, the compressed air stops being injected from the auxiliary nozzle 19e. Then, the normal true-twisting-like spinning process is resumed. Further, the central control device C1 detects the time elapsing after the start of the yarn discharging spinning to determine whether or not the timing has been reached with which the yarn feeding member 7 starts exerting force for feeding the yarn Y. On the basis of this detection, via the motor driver MD1, the rotation of the individual-spindle-driving motor M1 is returned to the rotation speed for the normal yarn generating process (time T7 in Figure 5). Alternatively,

to determine the timing for the time t7 in Figure 5, a yarn detecting sensor may be disposed in the suction nozzle (a1) to eliminate the need for the central control unit C1 to detect that the yarn feeding member 7 has started exerting force for feeding the yarn Y. This enables the apparatus to more reliably detect that the yarn discharging spinning has succeeded and that the yarn spun out by this spinning has been successfully captured. Alternatively, instead of causing the central control device C1 to detect the above described elapsed time, it is possible to return, during the yarn discharging spinning, the changed total draft ratio to the normal total draft ratio when or immediately after the suction nozzle (a1) positioned close to the yarn discharge port 19g starts to rotationally move downward after sucking and capturing the yarn Y discharged from the yarn discharge port 19g in the hollow guide shaft 19. This arrangement enables the minimization of length of a thicker portion of the yarn generated (between time t3 and time t7 in Figure 5) on the basis of the changed total draft ratio. This serves to avoid the situation in which part of such a thicker portion fails to be disposed of and is used for joining and thus wound around the package 10.

[0052] On the other hand, during a normal yarn generating process, if yarn breakage occurs while a spun yarn Y of a larger yarn count is being generated, when the above described yarn discharging spinning is carried out by supplying the spinning member (S) with the same amount of fibers as that used for a normal operation of generating a yarn of a larger yarn count, the amount of fibers so large that the opening 19h in the hollow guide shaft 19, constituting the spinning member (S), may be filled with the fibers. Thus, the yarn discharging spinning may fail. In such a case, in resuming the spinning process, the central control device C1 reduces the rotation speed of the individual-spindle-driving motor M1 via the motor driver MD1. This raises the total draft ratio and reduces the amount of fibers supplied to the spinning member (S). This operation is the same as that in the above described embodiment except that the amount of fibers supplied to the spinning member (S). Its detailed description is thus omitted.

[0053] As described above, the success rate of the yarn discharging spinning can be improved by controlling the rotation speeds of the back roller 3 and third roller 4, constituting the draft device (D), to change the total draft ratio of the draft device (D) to properly adjust the amount of fibers supplied to the spinning member (S).

[0054] Further, the total draft ratio is changed by controlling the rotation speeds of the back roller 3 and the third roller 4 without controlling the rotation speed of the front roller 6. Consequently, the spinning speed of the yarn Y remains unchanged. This allows the success rate of the yarn discharging spinning to be improved even if the spinning speed of the normal spinning is high speed. It is unnecessary to change the rotation speed of the second roller 5, front roller 6, yarn feeding member 7, or friction roller 13, i.e. the rotation speed of the common

motor M2, which executes synchronous control, even when the spinning speed is changed. Therefore, the yarn discharging spinning can be stably carried out. It is also possible to simplify the control of the spinning apparatus.

[0055] The above described embodiment shows the example in which during the yarn discharging spinning, the rotation speed of the individual-spindle-driving motor M1, which rotationally drives the back roller 3 and the third roller 4, is changed according to a command from the central control device C1. However, the back roller 3 and the third roller 4 may be rotationally moved by the common motor M2, disposed in the motor box E1, whereas the front roller 6 may be rotationally moved by the individual-spindle-driving motor M1. In this case, the total draft ratio of the draft device (D) can be increased by increasing the rotation speed of the individual-spindle-driving motor M1 and thus the rotation speed of the front roller 6. In contrast, the total draft ratio of the draft device (D) can be reduced by reducing the rotation speed of the individual-spindle-driving motor M1 and thus the rotation speed of the front roller 6. This is because during the normal spinning, the second roller 5 rotates faster than the back roller 3 and the third roller 4, and because during the normal spinning, the front roller 6 rotates faster than the second roller 5. In particular, the difference in rotation speed between the second roller 5 and the front roller 6 is set to be larger than the other differences.

[0056] Thus, in particular, when the yarn Y of a smaller yarn count is spun, if during the yarn discharging spinning, the rotation speed of the individual-spindle-driving motor M1 is lowered to reduce the draft ratio of the draft device (D), then a yarn of a large yarn count is obtained during the yarn discharging spinning, and the spinning speed can be reduced. It is thus possible to allow whirling air currents from the nozzle hole 17d and auxiliary nozzle 19e to more reliably act on the bundle of fibers. Therefore, the success rate of the yarn discharging spinning can be further improved.

[0057] As described above, if the rotation speed of the front roller 6 is changed to change the total draft ratio of the draft device (D), then the resulting spinning speed (yarn generation speed) of the spinning member (S) differs from the one used in the normal spinning state. Accordingly, in such a case, the motor driver MD1 may give a command to change the rotation speeds of the second roller 5, yarn feeding member 7, and friction roller 13 so as to control the second roller 5, the yarn feeding member 7, and the friction roller 13 so as to synchronize with one another.

[0058] The spinning member (S) need not be composed of the nozzle hole 17d and the hollow guide shaft 19 in which the auxiliary nozzle 19e are formed. For example, a fasciated yarn may be generated using two nozzles that whirling air currents in different directions. Alternatively, a fasciated yarn may be generated using one nozzle and a pair of twisting rollers.

[0059] The present invention is configured as described above and thus produces the effects described

below.

[0060] Before the yarn discharging spinning, the amount of fibers supplied per unit time in the normal spinning state is changed to the amount of fibers supplied per unit time during the yarn discharging spinning, the latter amount being different from the former amount. Therefore, the success ratio of the yarn joining increases.

[0061] The yarn feeding device is provided which exerts feeding force on a yarn spun out by the spinning member, and on the basis of the timing with which yarn feeding device starts exerting yarn feeding force, the changed amount of fibers supplied is returned to the amount of fibers supplied in the normal spinning state. Consequently, the yarn count is changed after the yarn feeding member has started feeding the yarn stably. This enables the spun-out yarn to be more reliably fed out downstream.

[0062] At least one of the plurality of draft rollers constituting the draft device and rotating at different speeds is driven by the motor that drives each spinning unit. The control means is disposed which controls the rotation speed of the motor for each spinning unit. Consequently, it is possible to change the total draft ratio of the spinning unit which needs the yarn discharging spinning without influence on other spinning units which perform the normal spinning.

Claims

1. A spinning method of drafting supplied fibers (1) at a predetermined total draft ratio and then spinning the fibers using a spinning member (S) composed of a nozzle member (17) having a nozzle hole (17d), the method being **characterized in that** before yarn discharging spinning, the amount of fibers supplied to said spinning member (17) per unit time in a normal spinning state is changed to the amount of fibers supplied per unit time during the yarn discharging spinning, the latter amount being different from the former amount, and after the yarn discharging spinning has ended, the changed amount of fibers supplied is returned to the amount of fibers supplied in the normal spinning state.
2. A spinning method according to Claim 1, **characterized in that** a yarn feeding device is provided which exerts feeding force on a yarn spun out by said spinning member, and on the basis of a timing with which the yarn feeding device starts exerting yarn feeding force, said changed amount of fibers supplied is returned to the amount of fibers supplied in the normal spinning state.
3. A spinning method according to Claim 1 or Claim 2, **characterized in that** said amount of fibers supplied can be changed by changing, before the yarn discharging spinning, the total draft ratio to one different

from the total draft ratio used in the normal spinning state, and returning said changed total draft ratio to the total draft ratio used in the normal spinning state, after the yarn discharging spinning has ended.

4. A spinning method according to any one of Claim 1 to Claim 3, **characterized in that** said spinning member is composed of a nozzle member having a nozzle hole and a hollow guide shaft, and for a yarn joining operation, the yarn discharging spinning is carried out by injecting a whirling air current from said nozzle member and injecting compressed air from an auxiliary nozzle formed in the hollow guide shaft, into a yarn passage to generate suction force directed from an opening formed in a tip of the hollow guide shaft, toward a yarn discharge port.
5. A spinning apparatus comprising a draft device (D) which drafts supplied fibers and a spinning member (S) composed of a nozzle member (17), the apparatus being **characterized by** further comprising fiber supply amount control means which can operate to switch the amount of fibers per unit time supplied to the spinning member by the draft device in a normal spinning state, to the amount of fibers supplied to the spinning member by the draft device during yarn discharging spinning and normal spinning state.
6. A spinning apparatus according to Claim 5, **characterized by** further comprising a yarn feeding device which exerts feeding force on a yarn spun out by said spinning member, and in that said control means provides such control that the changed amount of fibers supplied is returned to the amount of fibers supplied in the normal spinning state, on the basis of a timing with which the yarn feeding device starts exerting yarn feeding force.
7. A spinning apparatus according to Claim 5 or Claim 6, **characterized in that** said control means is total draft ratio change control means which can change a total draft ratio of said draft device used in a normal spinning state to one for yarn discharging spinning.
8. A spinning apparatus according to Claim 7, **characterized by** comprising a plurality of spinning units arranged in line and each comprising said draft device and spinning member, and in that the draft device is composed of a plurality of draft rollers rotating at different rotation speeds, and at least one of said plurality of rollers can be controlled to rotate at one of different speeds corresponding to the respective spinning units.
9. A spinning apparatus according to Claim 8, **characterized in that** the roller that can be controlled to rotate at one of the different speeds corresponding to the respective spinning units is different from a

front roller.

10. A spinning apparatus according to Claim 8 or Claim 9, **characterized in that** said at least one of said plurality of rollers is driven by a motor that drives a corresponding one of the spinning units, and control means is disposed which controls the rotation speed of said motor for each spinning unit.
11. A spinning apparatus according to Claim 10, **characterized in that** said motor is a stepping motor.
12. A spinning apparatus according to any one of Claim 5 to Claim 11, **characterized in that** said spinning member is composed of a nozzle member and a hollow guide shaft, and an auxiliary nozzle is provided which injects, during yarn discharging spinning, compressed air into a passage in the hollow guide shaft to generate suction force directed from an opening formed in a tip of the hollow guide shaft, toward a yarn discharge port.

Patentansprüche

1. Spinnverfahren, bei dem zugeführte Fasern (1) mit einem bestimmten Gesamtstreckverhältnis gestreckt und dann die Fasern mittels eines Spinnlements (S), das aus einem Düsenelement (17) mit einer Düsenöffnung (17a) besteht, gesponnen werden, **dadurch gekennzeichnet, dass** vor dem Fadenanspinnen die Menge der dem Spinnlement (17) pro Zeiteinheit in einem normalen Spinnzustand zugeführten Fasern auf die Menge Fasern, die pro Zeiteinheit während des Fadenanspinnens zugeführt werden, geändert wird, wobei letztere Menge von ersterer Menge verschieden ist, und nachdem das Fadenanspinnen beendet ist, die geänderte Menge Fasern, die zugeführt werden, auf die Menge Fasern, die im normalen Spinnzustand zugeführt werden, zurückgestellt wird.
2. Spinnverfahren nach Anspruch 1, **dadurch gekennzeichnet, dass** eine Fadenvorschubvorrichtung vorgesehen ist, die eine Vorschubkraft auf einen vom Spinnlement gesponnenen Faden ausübt und auf der Grundlage eines Zeitpunktes, bei dem die Fadenvorschubrichtung beginnt, die Fadenvorschubkraft auszuüben, die geänderte Menge Fasern, die zugeführt werden, auf die Menge Fasern, die im normalen Spinnzustand zugeführt werden, zurückgestellt wird.
3. Spinnverfahren nach Anspruch 1 oder 2, **dadurch gekennzeichnet, dass** die Menge Fasern, die zugeführt werden, **dadurch** geändert werden kann, dass vor dem Fadenanspinnen das Gesamtstreckverhältnis auf eines geändert wird, das von dem Ge-

samtstreckverhältnis verschieden ist, das im normalen Spinnzustand verwendet wird, und das geänderte Gesamtstreckverhältnis auf das Gesamtstreckverhältnis, das im normalen Spinnzustand verwendet wird, nach Beendigung des Fadenanspinnens zurückgestellt wird.

4. Spinnverfahren nach einem der Ansprüche 1 bis 3, **dadurch gekennzeichnet, dass** das Spinnenelement aus einem Düsenelement besteht, das eine Düsenöffnung und einen hohlen Führungsschaft hat, und für einen Fadenverbindungs Vorgang das Fadenanspinnen **dadurch** durchgeführt wird, dass ein Wirbelluftstrom aus dem Düsenelement und Druckluft aus einer Hilfsdüse, die im hohlen Führungsschaft ausgebildet ist, in einen Kanal eingeblasen werden, um eine Saugkraft zu erzeugen, die von einer Öffnung am vorderen Ende des hohlen Führungsschafts zu einer Fadenaustrittsöffnung gerichtet ist.
5. Spinnvorrichtung, bestehend aus einem Streckwerk (D), das zugeführte Fasern verstreckt, und einem Spinnenelement (S) mit einem Düsenelement (17) **gekennzeichnet durch** eine Faserzufuhrmengen-Steuereinrichtung, die die Menge Fasern pro Zeiteinheit, die dem Spinnenelement **durch** das Streckwerk im normalen Zustand zugeführt werden, auf die Menge Fasern umschalten kann, die dem Spinnenelement vom Streckwerk während des Fadenanspinnens und des normalen Spinnzustandes zugeführt werden.
6. Spinnvorrichtung nach Anspruch 5, **gekennzeichnet durch** eine Fadenvorschubvorrichtung, die eine Vorschubkraft auf einen vom Spinnenelement gesponnenen Faden ausübt, und **dadurch**, dass die Steuereinrichtung eine solche Steuerung durchführt, dass die geänderte Menge zugeführter Fasern auf die Menge von Fasern, die im normalen Zustand zugeführt werden, auf der Grundlage des Zeitpunktes, bei dem die Fadenvorschubvorrichtung beginnt, die Fadenvorschubkraft auszuüben, zurückgestellt wird.
7. Spinnvorrichtung nach Anspruch 5 oder 6, **dadurch gekennzeichnet, dass** die Steuereinrichtung eine Gesamtstreckverhältnis-Änderungssteuereinrichtung ist, die das Gesamtstreckverhältnis des Streckwerks, das im normalen Spinnzustand verwendet wird, auf eines zum Fadenanspinnen ändern kann.
8. Spinnvorrichtung nach Anspruch 7, **gekennzeichnet durch** mehrere Spinnstellen, die in einer Linie angeordnet sind und von denen jede ein Streckwerk und ein Spinnenelement aufweist, und **dadurch**, dass das Streckwerk aus mehreren Streckrollen besteht, die sich mit unterschiedlichen Drehgeschwindigkeiten drehen, und wenigstens eine der Rollen so ge-

steuert werden kann, dass sie mit einer von verschiedenen Geschwindigkeiten entsprechend den jeweiligen Spinnstellen dreht.

- 5 9. Spinnvorrichtung nach Anspruch 8, **dadurch gekennzeichnet, dass** die Rolle, die so gesteuert werden kann, dass sie mit einer von verschiedenen Geschwindigkeiten entsprechend den jeweiligen Spinnstellen dreht, keine vordere Rolle ist.
- 10 10. Spinnvorrichtung nach Anspruch 8 oder 9, **dadurch gekennzeichnet, dass** wenigstens eine der Rollen von einem Motor angetrieben wird, der eine entsprechende der Spinnstellen antreibt, und eine Steuereinrichtung vorhanden ist, die die Drehgeschwindigkeit des Motors für jede Spinnstelle steuert.
- 11 11. Spinnvorrichtung nach Anspruch 10, **dadurch gekennzeichnet, dass** der Motor ein Schrittmotor ist.
- 20 12. Spinnvorrichtung nach einem der Ansprüche 5 bis 11, **dadurch gekennzeichnet, dass** das Spinnenelement aus einem Düsenelement und einem hohlen Führungsschaft besteht, und eine Hilfsdüse vorgesehen ist, die während des Fadenanspinnens Druckluft in einen Kanal im hohlen Führungsschaft einbläst, um eine Saugkraft zu erzeugen, die von einer Öffnung, die am vorderen Ende des hohlen Führungsschafts ausgebildet ist, zu einer Fadenaustrittsöffnung gerichtet ist.

Revendications

- 35 1. Procédé de filage d'étirage de fibres (1) à un rapport d'étirage total prédéterminé et ensuite filage des fibres utilisant un organe de filage (S) composé d'un organe à filière (17) ayant une trou de filière (17a), le procédé étant **caractérisé en ce qu'**avant le préfilage, la quantité de fibres amenées audit organe de filage (17) par unité de temps en un état normal de filage est modifiée en quantité de fibres alimenté par unité de temps pendant le filage de décharge de fil, cette dernière quantité étant différente de la première et à la fin du préfilage, la quantité modifiée de fibres alimentées est ramenée à la quantité de fibres alimentées à l'état normal de filage.
- 40 2. Procédé de filature selon la revendication 1, **caractérisé en ce qu'**un dispositif d'alimentation de fil est prévu qui exerce une force d'alimentation sur un fil par ledit organe de filage et sur la base d'une programmation temporelle avec laquelle le dispositif d'alimentation de fil commence à exercer une force d'alimentation de fil, ladite quantité modifiée de fibres alimentées est ramenée à la quantité de fibres alimentées à l'état normal de filage.
- 50
- 55

3. Procédé de filage selon la revendication 1 ou la revendication 2, **caractérisé en ce que** ladite quantité de fibres alimentées peut être changée par modification avant le préfilage, le rapport total d'étirage à une valeur différente du rapport d'étirage total utilisé dans l'état normal de filage et en ramenant ledit rapport d'étirage modifié total au rapport d'étirage total utilisé à l'état normal de filage après que le préfilage soit terminé. 5
4. Procédé de filage selon l'une des revendications 1 à 3, **caractérisé en ce que** ledit organe de filage est composé d'un organe de filière ayant un trou de filière et un arbre de guidage creux et pour une opération de jonction de fil, le préfilage est effectué par injection d'un courant d'air tourbillonnaire provenant du dit organe de filière et par injection d'air comprimé provenant d'une filière auxiliaire formée dans l'arbre de guidage creux, à l'intérieur d'un passage de fil pour générer une force d'aspiration dirigée depuis une ouverture formée dans une extrémité de l'arbre de guidage creux en direction d'un orifice d'évacuation de fil. 10
5. Appareil de filage comprenant un dispositif d'étirage (D) qui étire les fibres alimentées et un organe de filage (S) composé d'un organe de filière (17), l'appareil étant **caractérisé en ce qu'il** comprend en outre des moyens de commande de quantité alimentée de fibres qui peuvent commuter la quantité de fibres alimentées par unité de temps à l'organe de filage par le dispositif d'étirage à l'état de filage normal à la quantité de fibres alimentées à l'organe de filage par le dispositif d'étirage pendant le préfilage et l'état normal de filage. 15
6. Appareil de filage, selon la revendication 5, **caractérisé en ce qu'il** comprend en outre un dispositif d'alimentation de fil qui exerce la force d'alimentation sur un fil filé par ledit organe de filage et **en ce que** ledit moyen de commande assure une telle commande de sorte que la quantité changée de fibres alimentées est ramenée à la quantité de fibres alimentées dans l'état de filage normal sur la base d'une programmation avec laquelle le dispositif de filage de fil commence à exercer une force d'alimentation de fil. 20
7. Appareil de filage selon la revendication 5 ou la revendication 6, **caractérisé en ce que** ledit moyen de commande est un moyen de commande de modification de rapport total d'étirage qui peut changer un rapport d'étirage total dudit dispositif d'étirage utilisé à l'état normal de filage à un rapport correspondant pour le préfilage. 25
8. Appareil de filage selon la revendication 7, **caractérisé en ce qu'il** comprend une pluralité d'unités de filage alignées qui comprennent chacune ledit dispositif d'étirage et l'organe de filage et **en ce que** le dispositif d'étirage est composé d'une pluralité de rouleaux d'étirage tournant à des vitesses de rotation différentes et au moins l'un desdits plusieurs rouleaux peut être commandé pour tourner à l'une des vitesses différentes correspondant aux unités respectives de filage. 30
9. Appareil de filage selon la revendication 8, **caractérisé en ce que** le rouleau qui peut être commandé pour tourner à une des vitesses différentes correspondant aux vitesses respectives de filage est différent d'un rouleau frontal. 35
10. Appareil de filage selon la revendication 8 ou la revendication 9, **caractérisé en ce que** l'un desdits rouleaux est entraîné par un moteur qui entraîne une unité correspondante de filage et le moyen de commande est disposé de manière à commander la vitesse de rotation dudit moteur pour chaque unité de filage. 40
11. Dispositif de filage selon la revendication 10, **caractérisé en ce que** ledit moteur est un moteur pas à pas. 45
12. Dispositif de filage selon l'une des revendications 5 à 11, **caractérisé en ce que** ledit organe de filage est composé d'un organe de filière et d'un arbre de guidage creux et une filière auxiliaire est prévue qui injecte pendant le préfilage, l'air comprimé dans un passage dans l'arbre de guidage creux pour générer la force d'aspiration dirigée depuis une ouverture formée dans une extrémité de l'arbre de guidage creux en direction de l'orifice de décharge du fil. 50

FIG. 1

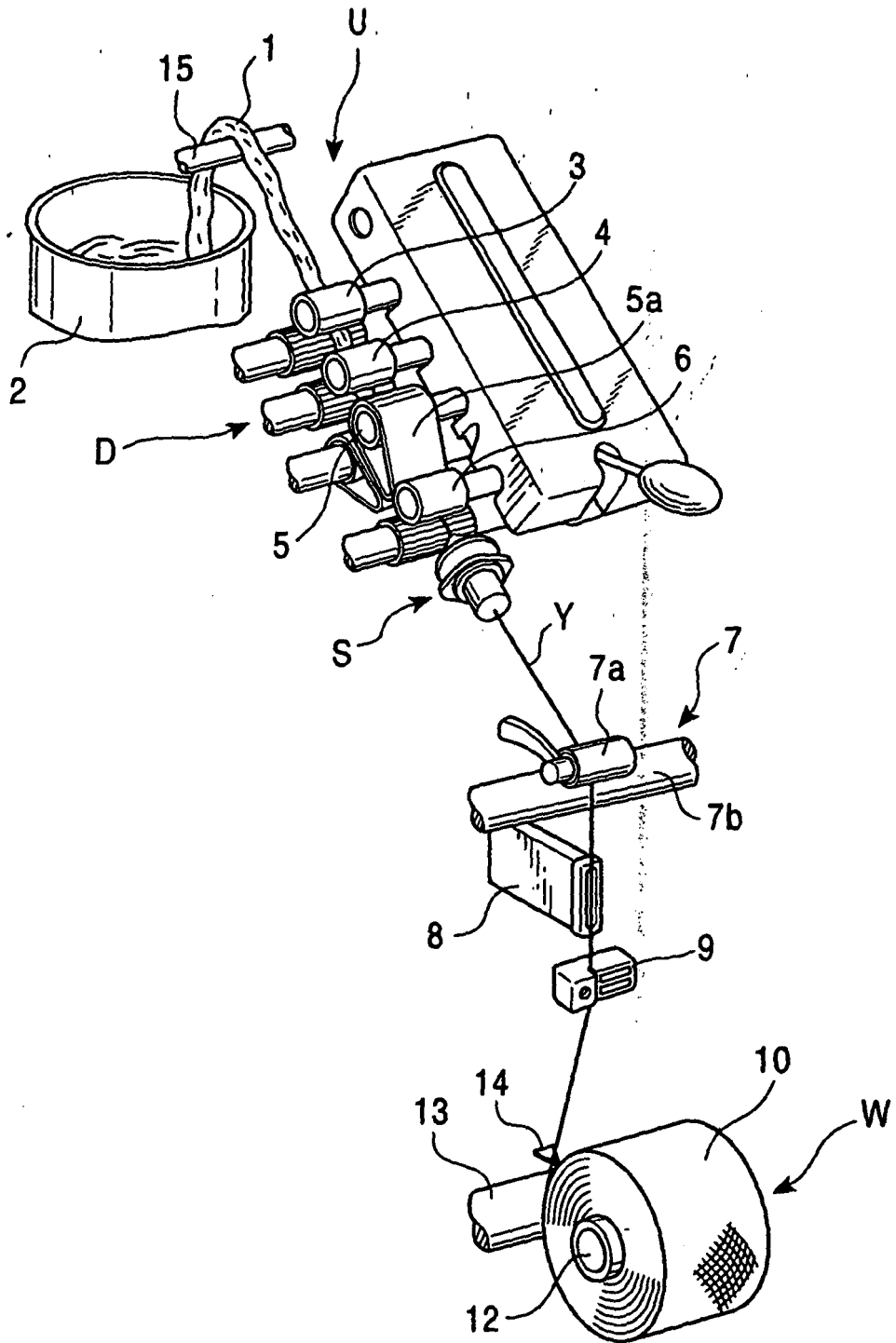

FIG. 2

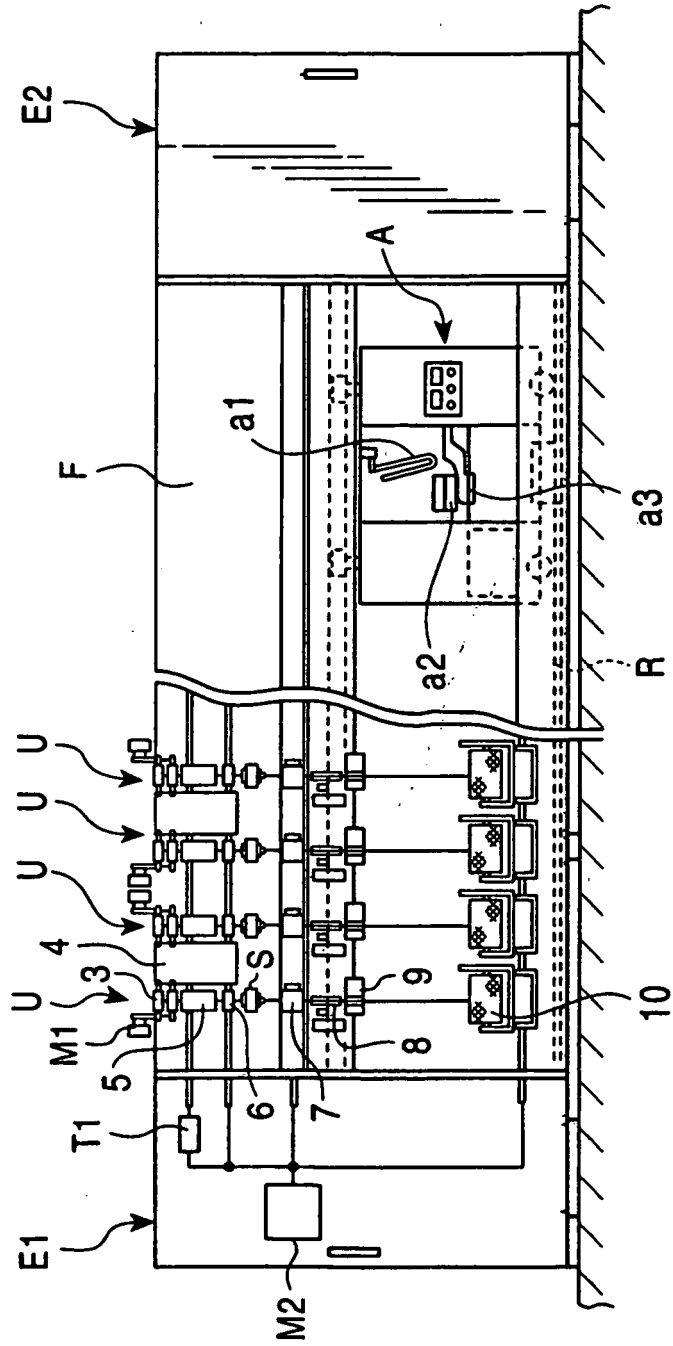

FIG. 3

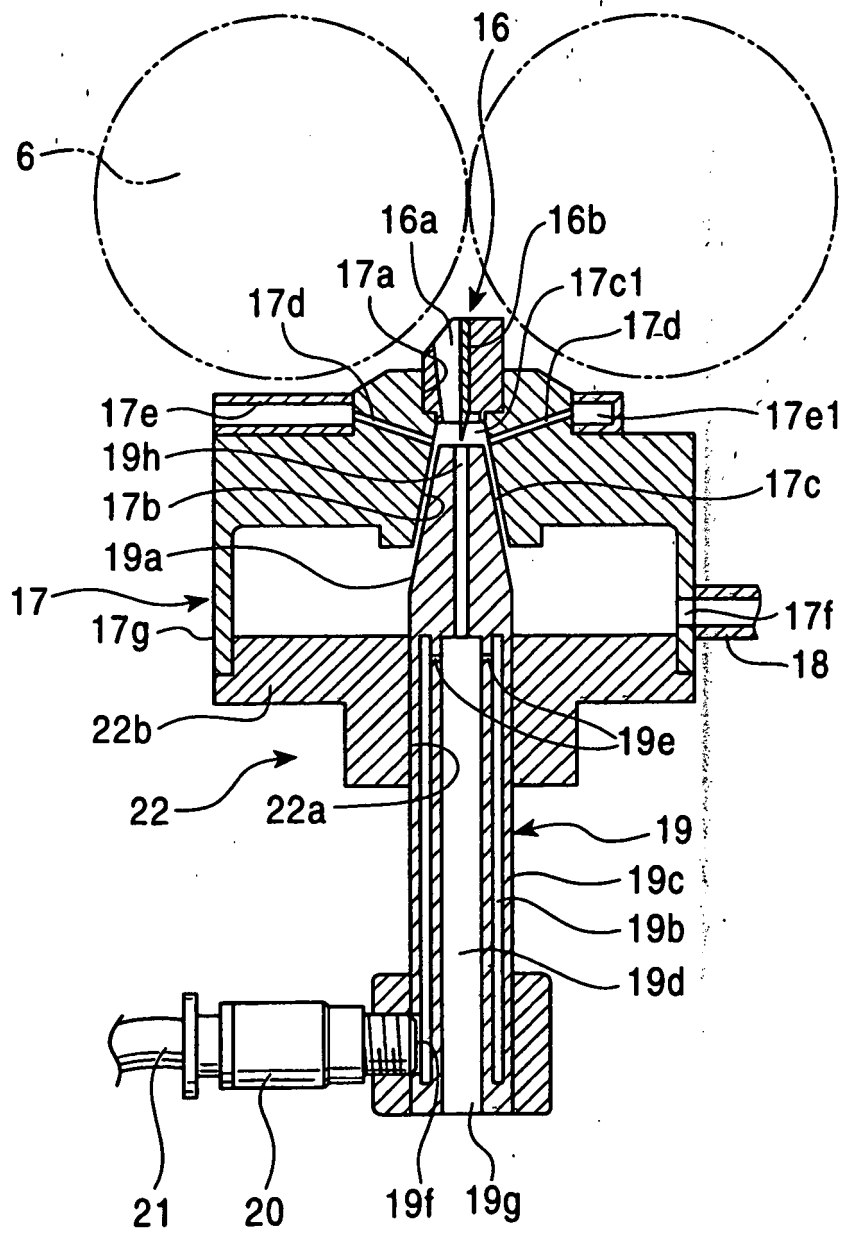

FIG. 4

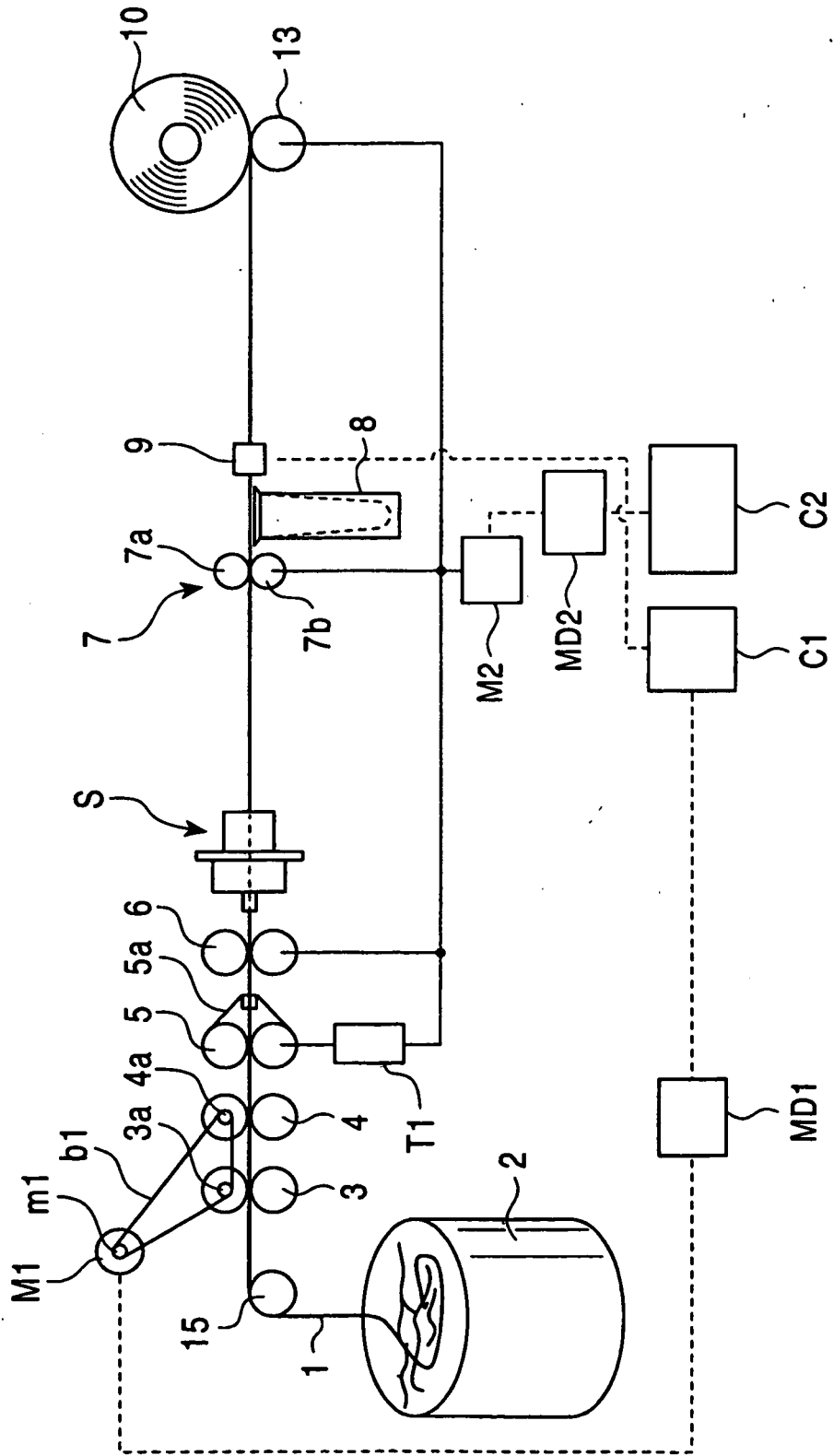

FIG. 5

