

(No Model.)

2 Sheets—Sheet 1.

S. G. DERHAM.
FILTER.

No. 526,027.

Patented Sept. 18, 1894.

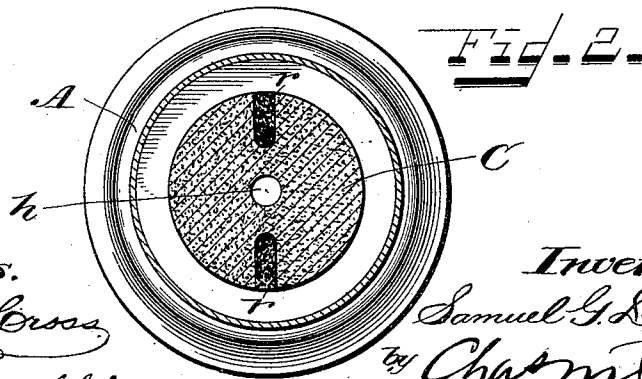
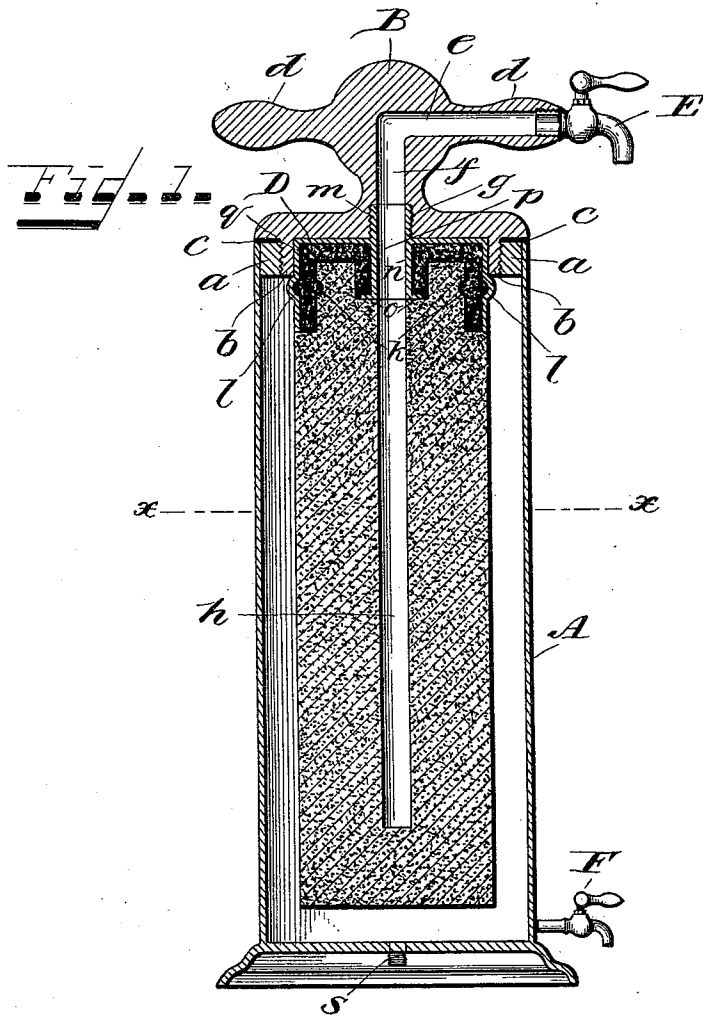

Witnesses.
J. Thomson Cross
Bernard H. Kaufeld

Inventor:
Samuel G. Derham
 by *Chas. M. Beck*
 his Attorney.

(No Model.)

2 Sheets—Sheet 2.

S. G. DERHAM.
FILTER.

No. 526,027.

Patented Sept. 18, 1894.

FIG. 3.

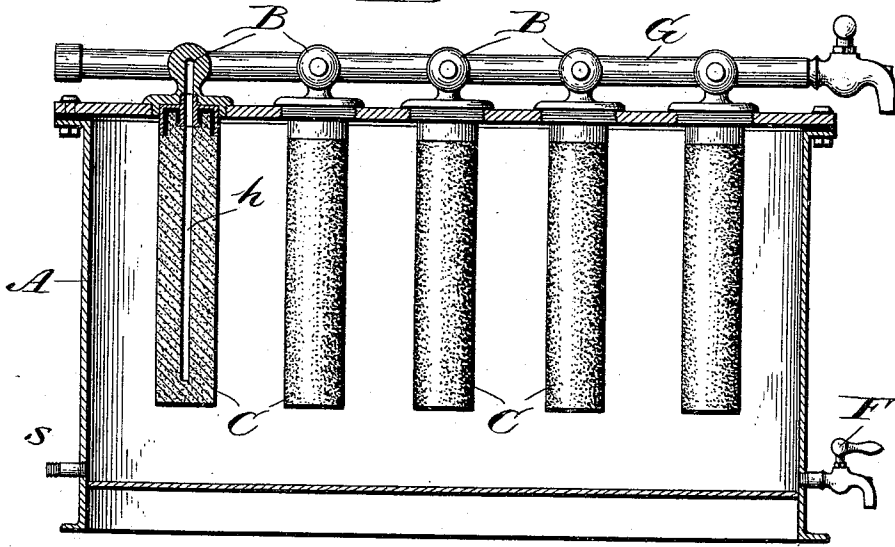
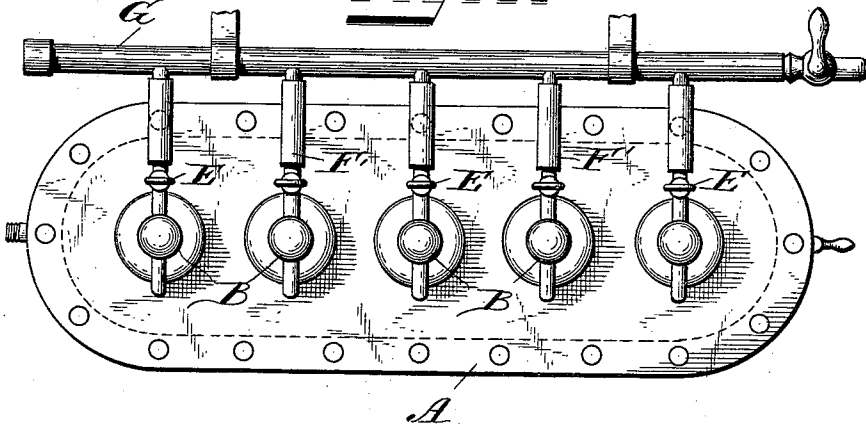

FIG. 4.



Witnesses.
J. Thomson Cross
Bernard Krausfeld.

Inventor:
Samuel G. Derham
by Chas. M. Peck
his Attorney.

UNITED STATES PATENT OFFICE.

SAMUEL G. DERHAM, OF CINCINNATI, OHIO, ASSIGNOR OF ONE-HALF TO
HENRY VERHAGE, OF SAME PLACE.

FILTER.

SPECIFICATION forming part of Letters Patent No. 526,027, dated September 18, 1894.

Application filed March 15, 1894. Serial No. 503,711. (No model.)

To all whom it may concern:

Be it known that I, SAMUEL G. DERHAM, a citizen of the United States, residing at Cincinnati, in the county of Hamilton and State of Ohio, have invented certain new and useful Improvements in Filters, of which the following is a full, clear, and exact description, reference being had to the accompanying drawings, forming part of this specification.

My invention relates to pressure filters of that class employing tubular filtering media, usually tripoli, and it has for its object the improved and simplified construction of the same.

The novelty of my invention will be hereinafter set forth and specifically pointed out in the claims.

In the accompanying drawings:—Figure 1, Sheet 1, is a central sectional elevation of one form of filter embodying my invention. Fig. 2, Sheet 1, is a transverse section on the dotted line $x-x$ of Fig. 1. Fig. 3, Sheet 2, is a sectional elevation of another form of filter embodying my invention. Fig. 4, Sheet 2, is a plan view of the filter of Fig. 3.

The same letters of reference are used to indicate identical parts in all the figures.

Referring to Figs. 1 and 2, A is the filtering chamber of metal and tubular in form. It has at its upper open end an inturned boss interiorly threaded to receive the exteriorly threaded flange b projecting from the under side of the combined cover and head piece B whose cover portion is of the same diameter as the filtering chamber and fits thereon, when screwed down, with an interposed rubber gasket c . The top of the head B is spherical with two laterally projecting handles d by which the head and cover are conveniently grasped in screwing and unscrewing the same. One of these handles has a bore e through it extending to the center of the spherical portion of the head and communicating with a central vertical bore f through the cover, whose lower end is enlarged and threaded as at g .

The filtering medium is a cylindrical block C of tripoli or other sufficiently porous stone or composition having a vertical central bore h which at its upper end is enlarged, as at i , and the outer side at the top is rabbeted off

as at j and with a circumferential groove k . To support and suspend the stone C in the chamber A, I provide a metal cap D with an external downturned flange of the same diameter as the stone and with a bead l in it opposite the groove k when the cap is applied and secured to the stone. Integral with and projecting up from the cap at its center is an exteriorly threaded nipple m to screw into and engage the threads at g in the bore f of the cover, and projecting down from the cap is another nipple n in line with the nipple m and having its lower end outwardly flanged as at o . The opening p through the cap and both nipples is coincident with and of the same size as the bores h f . When the cap is applied to the stone, Portland or other cement q , is first applied to the top of the stone and the cap is forced down into it and covers it, while plastic, and when it hardens the cap is securely locked to the stone by reason of the flange o , the groove k and bead l which form dove-tailing locks, as will be readily understood. It will thus be seen that the stone with the cap thus secured to it and provided with the nipple m can be readily screwed into and be unscrewed from the cover and the outer upper part of the cap fits up snugly into the flange b of the cover thus making both a secure and water-tight joint.

To secure the stone against breakage, I cut vertical grooves r , Fig. 2, in its outer side and extending its entire length, which grooves are filled with cement. If desired, cement may also be applied to the bottom of the stone. I have only shown two grooves in Fig. 2, but there may be more if desired.

The water to be filtered is taken into the chamber A at any convenient point, as at s , and passing through the stone escapes through the bores h , p , f and e , the latter of which has secured in it a faucet E for drawing off the filtered water.

E is a drain cock in the chamber A, for drawing off impurities in cleansing the filtering chamber.

In Figs. 3 and 4 I have shown the application of a series of stones to one large filtering chamber of oblong shape, though any other shape may be employed. The construction of the stones, the heads B, and their connec-

- tion together, is identically the same as before described. The cover of the large chamber has through it as many threaded apertures as there are stones and the heads B are
- 5 screwed into these apertures. The faucets E, normally open, are connected by pipes F', in this instance rubber tubing, to nipples *t* on a common discharge pipe G supported in any suitable manner.
- 10 In case of the breakage of any of the stones, its faucet E would be closed without stopping the operation of the filter, until a new stone with its cap attached was procured, when the pressure would be shut off from the filter, the
- 15 head carrying the broken stone unscrewed, its cap unscrewed and the new stone with its cap screwed into the removed head and then inserted into the chamber and screwed to place, as will be readily understood.
- 20 Having thus fully described my invention, I claim—
1. In a filter, the combination of a filtering chamber, a head piece screwed thereon and having an outlet for the filtered water, and a

filtering stone with a central bore and provided with a metal suspending cap locked thereto and having a threaded nipple to screw into said head and communicating with said bore and outlet for filtered water, substantially as described.

2. In a filter, the stone C having the bore *h*, the metal cap D having the threaded nipple *m* and secured to the stone by cement, in combination with the handled head B having the bores *e f*, and the filtering chamber, substantially as described.

3. In a filter, the combination of a series of suspended filtering stones in a filtering chamber, removable heads B containing outlets for the filtered water, and supporting and communicating with the stones, a faucet E for each head, the discharge pipe G and pipes F' connecting each faucet with the pipe G, substantially as described.

SAMUEL G. DERHAM.

Witnesses:

J. THOMSON CROSS,
BERNARD J. HAUSEFELD.