

[54] **TREATMENT OF CONTINUOUS FABRIC WEBS**

[72] Inventor: **Kurt Bruckner**, Michelstadt, Germany

[73] Assignee: **Bruckner-Apparatebau Michelstadt GmbH**, Erbach/Odenwald, Germany

[22] Filed: **March 3, 1971**

[21] Appl. No.: **120,530**

[52] U.S. Cl. ....8/151, 34/13, 34/62, 68/18 C, 68/20

[51] Int. Cl. ....F23b 7/00, F26b 21/04

[58] Field of Search.....8/137, 151; 68/18 C, 19.1, 68/20; 34/13, 62, 72

2,798,280 7/1957 Franklin.....26/18.5  
 3,158,886 12/1964 Grimes.....68/18 C X  
 3,525,163 8/1970 Boylan et al.....34/13

*Primary Examiner*—Walter A. Scheel

*Assistant Examiner*—Philip R. Coe

*Attorney*—Marshall & Yeasting

[57] **ABSTRACT**

The web is wet with a solvent, dried in a stream of circulating air in a drying chamber, and then cooled. A secondary stream of air is withdrawn from the circulating air, cooled in a condenser to recover solvent, reheated, and returned to the circulating air. The web leaving the drying chamber is precooled in a separate chamber by means of the secondary air stream, after such stream is cooled and before it is reheated.

[56] **References Cited**

**UNITED STATES PATENTS**

2,115,630 4/1938 Von Gruber-Rehenburg et al. ....8/151 X

**3 Claims, 1 Drawing Figure**

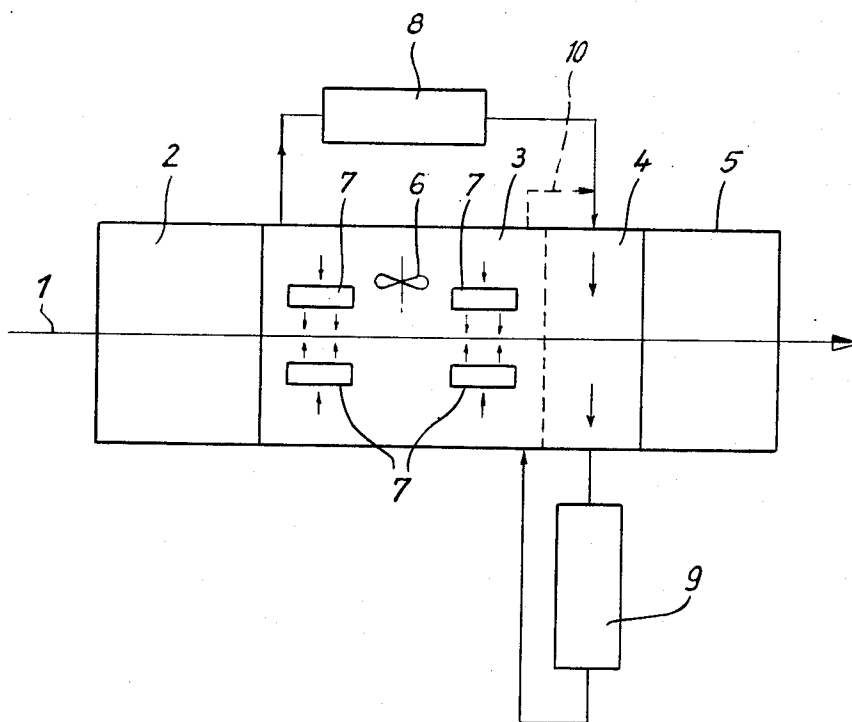

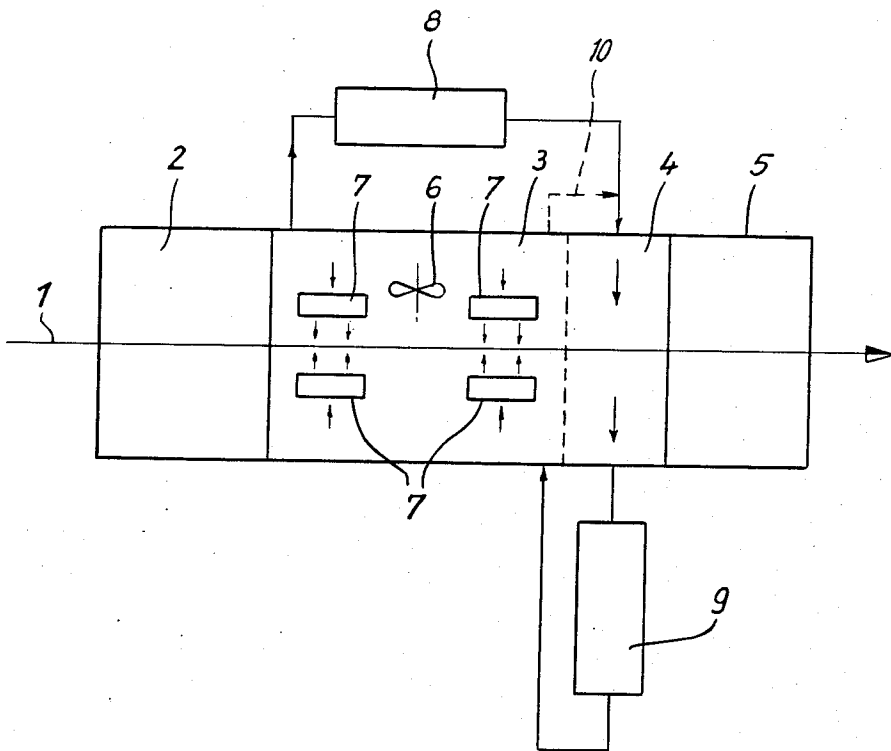

## TREATMENT OF CONTINUOUS FABRIC WEBS

### BACKGROUND OF THE INVENTION

This invention relates to a method of treating a continuous fabric web which is first subjected to wet treatment in a solvent, then dried in a stream of circulating air and then cooled, wherein there is withdrawn from the stream of circulating air a secondary air stream from which the vaporized solvent is recovered by condensation, whereupon this secondary air stream is again heated and returned to the main air stream.

This invention also relates to apparatus for carrying out this method.

During textile finishing a web of fabric must often be subjected to a wet treatment. While in the past an aqueous solution of the treating medium was generally used, organic solvents have recently been increasingly used. Thus in the dyeing of textile fabrics for instance, chlorinated hydrocarbons are used as the solvents.

In view of their cost, these solvents are usually recovered after use. This is generally effected as follows:

The stream of circulating air used for drying the web of fabric is enriched with vaporized solvents. A secondary air stream is withdrawn from this drying air stream and undergoes a condensation cycle. This secondary air stream is thus first cooled to condense the solvent, and is then re-heated before being fed back into the drying zone.

### SUMMARY OF THE INVENTION

The object of this invention is to provide an improved method of the type described above, by means of which the energy consumption is reduced.

According to the invention this object is achieved in that the secondary air stream which has been cooled in order to condense the solvent, before being re-heated, is used for cooling the fabric web.

In general the fabric web has to be cooled from the drying temperature, usually over 100° C, down to room temperature. This requires a considerably cooling effect.

The invention makes use of the recognition that the secondary air stream which has been cooled to condense the solvent can itself be employed as a cooling medium which can be effectively used in cooling the fabric web. Thus while hitherto the secondary air stream after being cooled in order to condense the solvent was immediately re-heated so that it could be fed back into the drying zone, according to the invention it is first used as a cooling medium. In this way the energy requirements can be considerably reduced.

### BRIEF DESCRIPTION OF THE DRAWING

The drawing is a diagram of an apparatus for practicing the invention.

### DESCRIPTION OF THE PREFERRED EMBODIMENT

The fabric web 1 passes in sequence through a wet treatment zone 2, a drying zone 3, a pre-cooling zone 4 and a main (or subsequent) cooling zone 5.

In the wet treatment zone the fabric web 1 is subjected to any desired wet treatment in a solvent, preferably organic.

In the drying zone 3 the fabric web 1 is dried by hot air circulation, the air being circulated by one or more fans 6 inside the drying zone 3 and heated by a number of radiators 7.

5 Superimposed on this circulation of drying air is a secondary air stream by which a certain amount of air is continuously fed to a cooler 8. Through the cooling of this air stream the solvent contained therein is condensed and thus recovered.

10 Before the secondary air stream which has been cooled in cooler 8 is re-heated in a heater 9 and returned to the drying zone 3, it comes into contact, in the pre-cooler zone 4, with the hot fabric web and effectively cools the latter.

15 The further cooling of the fabric web 1 to about room temperature then takes place in the main cooling zone 5 with the aid of a separate cooling medium.

20 In order to prevent the secondary air stream which has been cooled in the cooler 8 from causing condensation phenomena on its entry into the pre-cooling zone 4, part of the uncooled circulating drying air stream can be added to the cooled secondary air stream (via pipe 10 shown in dotted lines).

25 In order to prevent solvent vapors from leaving the circulation system (including the pre-cooler zone 4 traversed by the cooled air stream), the pre-cooler zone 4 is to a large extent sealed in a gas-tight manner from the main cooling zone 5.

30 The secondary air stream withdrawn from the drying zone 3 for the purpose of condensing the solvent is preferably taken adjacent to the entry of fabric web 1, and is returned to the drying zone 3 adjacent to the fabric web outlet.

I claim:

35 1. A method of treating a continuous fabric web in a closed system, comprising the steps of wetting the web with a solvent, drying the web in a stream of circulating air in a drying chamber, and then cooling the web, a secondary stream of air being withdrawn from the circulating air, cooled in a condenser to recover solvent, reheated, and returned to the circulating air, wherein the improvement comprises the step of pre-cooling the web leaving the drying chamber, in a separate chamber by means of the secondary air stream, after such stream is cooled and before it is reheated.

40 2. A method according to claim 1 wherein a portion of the secondary stream of air is caused to bypass the cooling condenser in order to prevent undesired subsequent condensation.

50 3. Apparatus for treating a continuous fabric web, comprising a wet treatment chamber in which the web is wetted by a solvent, a drying chamber in which the solvent is evaporated from the web by hot air circulation, a secondary air circulation system for withdrawing 55 air from the drying chamber, including a cooling condenser through which the air is passed, and a heater for reheating the secondary air stream, which is connected to return the reheated air stream to the drying chamber, wherein the improvement comprises a separate chamber which is entered by the fabric web 60 leaving the drying chamber, which is connected in circuit with the secondary air stream between the condenser and the heater, and which is provided with a restricted outlet for the fabric web to minimize loss of the secondary air.

\* \* \* \* \*