

H. A. STEEN.
 LIQUID RHEOSTAT.
 APPLICATION FILED SEPT. 6, 1910.

1,030,850.

Patented June 25, 1912.

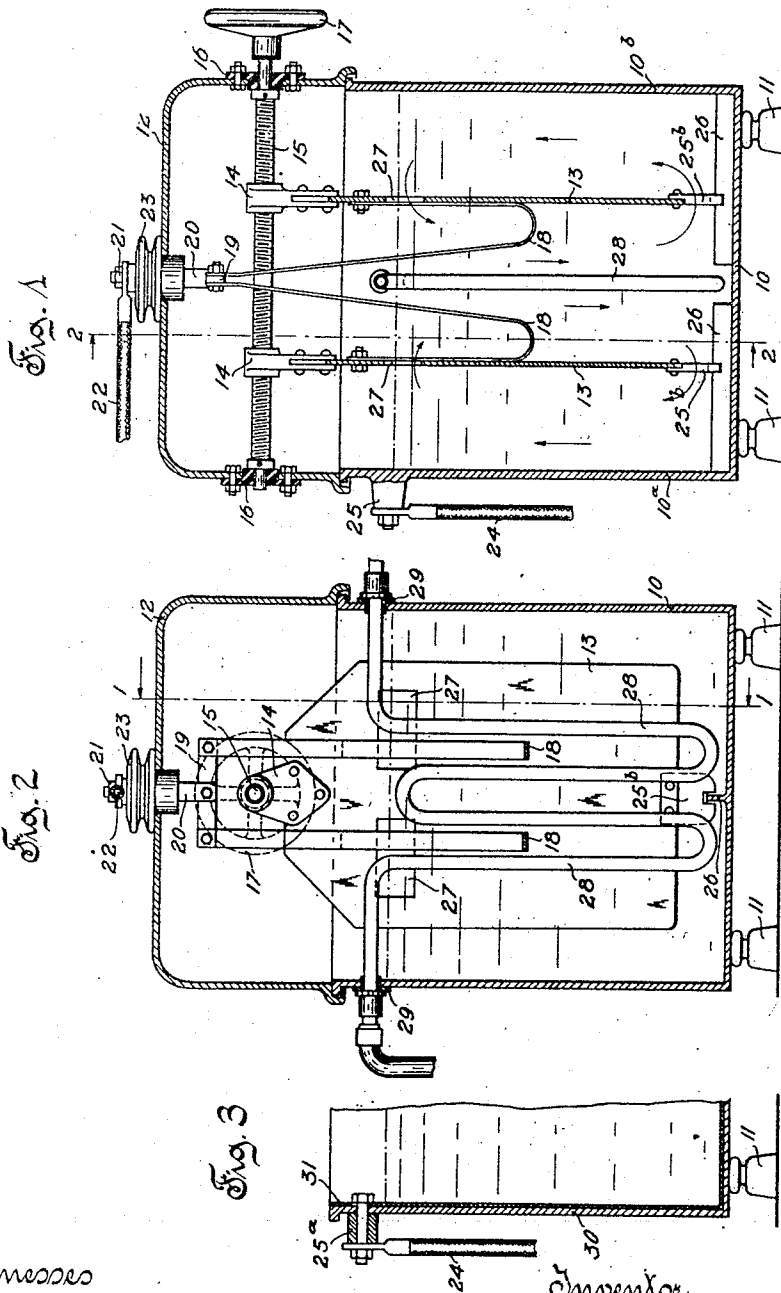

Witnesses
 Rob. E. Lora
 Chas. L. Byron.

Inventor
 Haldan A. Steen
 By Chas. E. Lora
 Attorney

UNITED STATES PATENT OFFICE.

HALFDAN A. STEEN, OF MILWAUKEE, WISCONSIN, ASSIGNOR TO ALLIS-CHALMERS COMPANY, A CORPORATION OF NEW JERSEY.

LIQUID RHEOSTAT.

1,030,850.

Specification of Letters Patent.

Patented June 25, 1912.

Application filed September 6, 1910. Serial No. 580,535.

To all whom it may concern:

Be it known that I, HALFDAN A. STEEN, a subject of the King of Norway, residing at Milwaukee, in the county of Milwaukee and State of Wisconsin, have invented certain new and useful Improvements in Liquid Rheostats, of which the following is a full, clear, and exact specification.

My invention relates to liquid rheostats. It is the object of my invention to improve the construction of liquid rheostats; and to provide one which is cheap, compact, durable, easy to manipulate, inspect, and repair, and not likely to get out of order.

A main feature of my invention is that one electrode is furnished by walls of the receptacle for the liquid, these walls being either integral parts of such receptacle if the latter is of metal, or interior linings of sides of the receptacle, if the latter be of concrete or other insulating material; while the other electrode is formed by plates immersed in the liquid and movable, preferably simultaneously, toward and away from such walls respectively. Preferably, the first electrode is furnished by two opposite walls of the receptacle and the second by two plates which are movable in opposite directions by a common operating device.

Another feature, which may be used either with the first or independently thereof, consists in providing artificial cooling means which will both diminish the heating of the rheostat and aid in the circulation of the liquid therein.

The various novel features of my invention will appear from the description and drawings and will be particularly pointed out in the claims.

Figure 1, is a section of a rheostat embodying my invention, the section being taken substantially on the line 1--1 of Fig. 2; Fig. 2 is a section taken substantially on the line 2--2 of Fig. 1, and Fig. 3 shows a fragmentary view showing a modification in which the receptacle for the liquid is of insulating material having walls lined with metal.

In the arrangement shown in Figs. 1 and 2, there is a metal receptacle or tank 10 which contains the liquid of the rheostat and furnishes one electrode of the latter. This tank which may be supported on insulators 11, has a removable, preferably metallic, cover 12, which carries the movable elec-

trode. This movable electrode comprises two plates 13 which depend from nuts 14 fitting on a right and left hand threaded rod 15 journaled in insulating blocks 16 in the cover 12 and operated by a hand wheel 17. The plates 13 are connected, by flexible conducting strips 18, to a bar 19 at the lower end of the rheostat terminal 20, the upper end of which furnishes a binding post 21 for connection to the leading-in conductor 22. The terminal 20 is supported in an insulator 23 mounted in the top of the cover 12. The other leading-in conductor 24 is connected to a binding post 25, mounted on or integral with the tank 10.

By turning the wheel 17, the plates may be moved in opposite directions along the rod 15, so that they simultaneously approach or recede from walls 10^a and 10^b respectively of the tank 10, thus decreasing or increasing the resistance of the rheostat. The plates 13 preferably have guides to prevent them from turning with the rod 15 when the latter is rotated, these guides here consisting of small plates 25^b of insulating material fastened to the bottoms of the plates 13 and slotted to fit over ridges 26 extending upward from the bottom of the tank 10. These ridges are shown integral with the tank, though it is not necessary that they be so. If it is necessary to inspect or repair the rheostat the cover 12 may be removed, carrying with it the whole operating mechanism and the movable electrode.

The liquid between the two plates 13 and the walls 10^a and 10^b respectively tends to become heated by the passage of the current, while that between the plates 13 has no such tendency. To equalize the heating of the liquid, the plates 13 are provided with openings 27 about on a level with the surface of the liquid, and the heating of the liquid between the plates 13 and the walls 10^a and 10^b produces a circulation of the liquid as indicated by the arrows in Fig. 1. This circulation is upward between the two plates 13 and the walls 10^a and 10^b, inward through the openings 27, downward between the plates 13, and outward beneath the lower edges of the plates 13. This circulation may be increased and the temperature of the liquid materially reduced by providing a cooling coil 28 in the space between the plates 13, a circulation of suitable cooling fluid being maintained through this coil.

Where the coil enters and leaves the tank 10 it is surrounded by insulating bushings 29, to prevent the coil 28, if a conductor, from becoming part of the electrode furnished by the tank 10.

If the receptacle for the liquid of the rheostat is made of some insulating material such as concrete 30 (Fig. 3), walls thereof may be lined with metal 31. This lining may be either a complete shell, lining the whole interior of the tank, or plates mounted on those walls of the tank toward and from which the plates 13 are movable. The lining 31 is connected to the binding post 25^a, to which the leading-in conductor 24 is connected, in any suitable fashion.

My invention is here shown in one of its simplest embodiments, and many modifications may be made in it without departing from the spirit and scope of my invention. All such I aim to cover in the following claims.

What I claim as new is:

1. In a liquid rheostat, a liquid-containing receptacle, walls of which furnish one electrode of the rheostat, a plurality of electrically connected plates located within the receptacle and forming another electrode thereof, and transmitting means adapted to move said plates toward and away from said respective walls.

2. In a liquid rheostat, a liquid-containing receptacle, walls of which furnish one electrode of the rheostat, a plurality of electrically connected plates located within the receptacle and forming another electrode thereof, and transmitting means adapted to move said plates simultaneously toward and away from said respective walls.

3. In a liquid rheostat, a liquid-containing receptacle, walls of which furnish one electrode of the rheostat, a plurality of electrically connected plates located within the receptacle and forming another electrode thereof, and transmitting members for moving such plates toward and away from said respective walls.

4. In the liquid rheostat, a liquid-containing receptacle, opposite walls of which form one electrode of the rheostat, a pair of electrically connected plates located within the liquid of the rheostat and forming another electrode thereof, and threaded means adapted to move said plates toward and away from said opposite walls respectively.

5. In the liquid rheostat, a liquid-containing receptacle, opposite walls of which form one electrode of the rheostat, a pair of electrically connected plates located within the liquid of the rheostat and forming another electrode thereof, and transmitting means for simultaneously moving said plates toward and from said opposite walls respectively.

6. In a liquid rheostat, a liquid-containing

receptacle, walls of which furnish one electrode of the rheostat, a plurality of electrically connected members located within the receptacle and forming another electrode thereof, said members being movable toward and away from said respective walls, said members having openings which permit a circulation of the liquid from one side to the other of the members and vertically in the spaces on the two sides of the members.

7. In a liquid rheostat, a liquid-containing receptacle walls of which furnish one electrode of the rheostat, a plurality of electrically connected members located within the receptacle and forming another electrode thereof, said members being movable toward and away from said respective walls, said members having openings which permit a circulation of liquid from one side to the other of the members and vertically in the spaces on the two sides of the members, and a cooling coil in the liquid in the space between the members.

8. A liquid rheostat including two relatively movable electrodes, one of such electrodes having an opening which permits the liquid to circulate from one side thereof to the other near the top and bottom of the liquid.

9. A liquid rheostat including two relatively movable electrodes, one of such electrodes having openings which permit the liquid to circulate from one side thereof to the other near the top and bottom of the liquid, and means for cooling the liquid on that side of such electrode which is remote from the other electrode.

10. A liquid rheostat having electrodes, the resistance of the liquid between which may be varied, and means for causing a circulation of the liquid through one of said electrodes and into and out of the space between such electrodes.

11. A liquid rheostat having electrodes, the resistance of the liquid between which may be varied, and a cooling coil in the liquid of the rheostat but exterior to the space between such electrodes.

12. In a liquid rheostat, an electrode immersed in liquid and having openings whereby the liquid may pass from one side thereof to the other both near the top and near the bottom of the liquid, and a second electrode on one side of said first electrode.

13. In a liquid rheostat, an electrode immersed in liquid and having openings whereby the liquid may pass from one side thereof to the other both near the top and near the bottom of the liquid, a second electrode on one side of said first electrode, and a cooling coil on the other side of said first electrode.

14. In a liquid rheostat, a receptacle containing a liquid and itself furnishing one electrode of the rheostat, one or more plates

depending into the liquid in said receptacle and movable relative to the latter, said plate or plates having openings to provide for circulation of said liquid, and a removable cover for said rheostat from which said plates are supported.

15. In a liquid rheostat, a receptacle containing liquid, a removable cover for said receptacle, a plurality of relatively movable plates supported by said cover and depending into the liquid to form an electrode of the rheostat, said plates being movable with respect to and removable with the cover.

16. In a liquid rheostat, two electrodes each comprising a pair of electrically connected plates, the four plates being arranged substantially in line with those of one electrode between those of the other, and means for moving the plates of one electrode relatively to each other and simultaneously toward or from the adjacent plates respectively of the other.

17. In a liquid rheostat, two electrodes, one of which comprises two electrically connected plates which are simultaneously movable toward or away from the other electrode but in opposite directions.

18. In a liquid rheostat, an electrode comprising a pair of electrically connected plates simultaneously movable in opposite directions, and another electrode comprising two plates arranged on opposite sides of the first two plates and substantially in line therewith in the direction of movement.

19. In a liquid rheostat, a liquid-contain-

ing-receptacle, and a pair of electrode plates at all times parallel within said receptacle, said plates being movable relatively to each other during the normal operation of the rheostat and movable relatively to the receptacle.

20. In a liquid rheostat, a liquid-containing-receptacle forming an electrode, and a pair of parallel connected electrode plates within said receptacle, and means for moving said plates toward and from each other and relatively to the receptacle.

21. In a liquid rheostat, a liquid-containing-receptacle forming an electrode, a plurality of parallel connected electrode plates within said receptacle, and unitary operating means for simultaneously moving said plates toward or from an intermediate point between such plates.

22. In a liquid rheostat, a receptacle containing a liquid and having portions of conducting material, a plurality of conducting plates immersed in said liquid and respectively forming a portion of a circuit including said liquid and different portions of said receptacle, said conducting plates being adapted to be moved relatively to said receptacle and relatively to each other.

Milwaukee, Wisconsin, August 23, 1910.

In testimony whereof I affix my signature, in the presence of two witnesses.

HALFDAN A. STEEN.

Witnesses:

CHAS. L. BYRON,
ROB. E. STOLL.