

(No Model.)

2 Sheets—Sheet 1.

C. F. PIKE.
ORE WASHER OR CONCENTRATOR.

No. 458,958.

Patented Sept. 1, 1891.

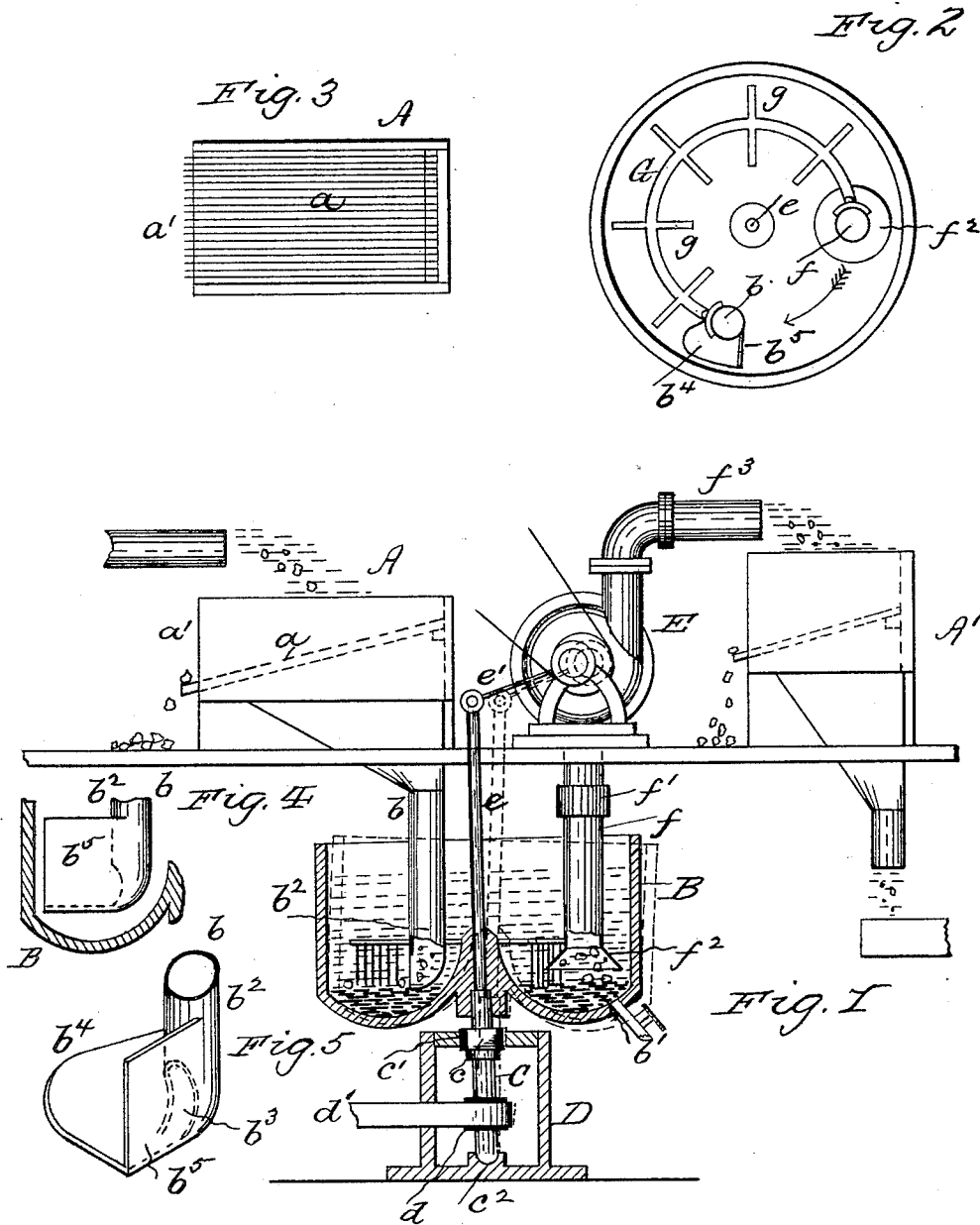

WITNESSES:
Chas. A. Huntington
Wm. K. Jones.

INVENTOR
Charles F. Pike.
By *S. J. Vandervoorn*
Attorney

(No Model.)

2 Sheets—Sheet 2.

C. F. PIKE.
ORE WASHER OR CONCENTRATOR.

No. 458,958.

Patented Sept. 1, 1891.

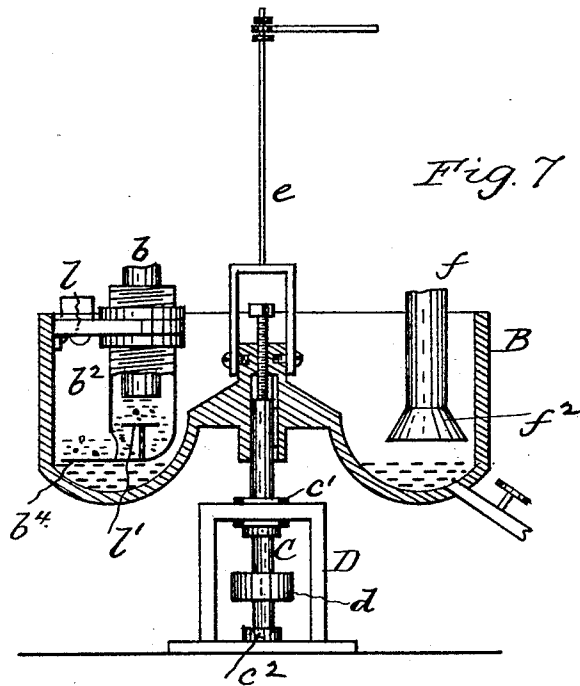
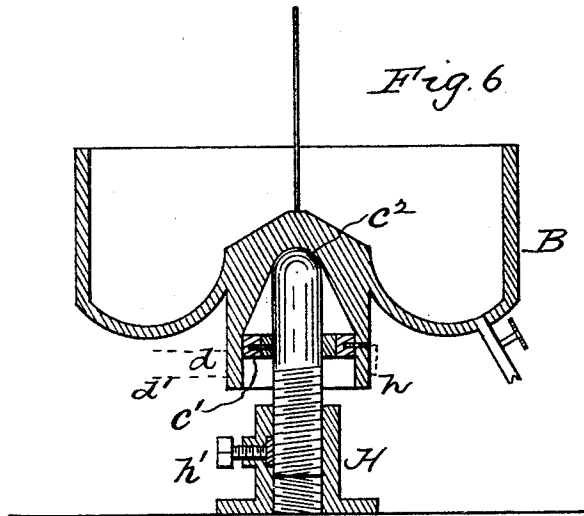

WITNESSES:

Wm. A. Byington
G. K. Jones

INVENTOR

Charles F. Pike

By S. J. VanStavorn
ATTORNEY

UNITED STATES PATENT OFFICE.

CHARLES F. PIKE, OF PHILADELPHIA, PENNSYLVANIA.

ORE WASHER OR CONCENTRATOR.

SPECIFICATION forming part of Letters Patent No. 458,958, dated September 1, 1891.

Application filed December 20, 1890. Serial No. 375,313. (No model.)

To all whom it may concern:

Be it known that I, CHARLES F. PIKE, a citizen of the United States, residing at Philadelphia, in the county of Philadelphia and State of Pennsylvania, have invented certain new and useful Improvements in Amalgamators; and I do hereby declare the following to be a full, clear, and exact description of the invention, such as will enable others skilled in the art to which it appertains to make and use the same.

My invention has relation to ore-amalgamators, which are particularly adapted for washing or concentrating scale gold or ore, wherein the gangue is supplied to a receiver containing mercury or analogous material; and it has for its object to more economically, rapidly, and thoroughly wash or concentrate scale or fine gold, so as to make the apparatus especially adapted for use in placer-mining, and also for treating dredged or raised river-bottom material containing fine ore. To this end the gangue as it enters the receiver is brought to a state of rest upon the mercury in the receiver, and the latter is agitated in any suitable manner to separate the ore from the gangue and the latter is forcibly raised by a suction-pump and discharged from the receiver.

My invention accordingly consists of the combinations, constructions, and arrangements of parts, as hereinafter more particularly described in the specification and pointed out in the claims.

Reference is had to the accompanying drawings, wherein—

Figure 1 is an elevation, partially in section, of an amalgamator apparatus embodying my improvements, the lower part of the supply-pipe for the receiver being broken away for the purpose of more clearly showing the rakes or fingers for distributing the gangue over the surface of the mercury in the receiver. Fig. 2 is a plan of the receiver, showing said supply-pipe distributor and also the suction-pump pipe. Fig. 3 is a plan of the grating-box for the receiver. Fig. 4 is a detail sectional elevation showing more plainly the construction of the lower end of the supply-pipe for the receiver. Fig. 5 is a perspective of said pipe end. Figs. 6 and 7 are sectional

elevations showing different modifications of construction for the receiver.

A in Figs. 1 and 3 represents a grate-box, in which the grating *a* is preferably inclined and may be flat, as shown in Fig. 3, or of any other suitable form, as desired, so as to have an open end *a'* for the waste or screenings to pass from, and an open bottom provided with a pipe or conduit *b*, leading into the receiver B, the bottom of which may be of any suitable configuration. In the drawings I have shown this bottom is in the form of an annular rounding, with central conical surface for the reception of a supply of mercury, (indicated at *b'*.)

The receiver B is secured to a spindle C, which has an upper bearing *e* in an elastic or rubber box *e'* in the top of the support D, and also a step-bearing *e²* in the bottom of said support. The spindle C is provided with a pulley *d* and belt, chain, or other power-transmitting device *d'*, suitably actuated, as desired. The belt and pulley *d' d* rotate the receiver B, and as its spindle C has its upper bearing in the elastic box *e'* the receiver is susceptible of being gyrated at the same time that it is rotated. This gyratory movement is effected in any suitable manner. In Fig. 1 I have shown a yielding or elastic rod *e*, which passes through the receiver and is stepped in the driving-shaft *l*, having a link connection *e'* with an eccentric located on the shaft of a suction, centrifugal, or coal pump E, from which pump extends a pipe *f*, having a slip-joint *f'* and a lower flaring or funnel-shaped end *f²*. This pipe *f* passes into the receiver B, so that its end *f²* is adjacent to the surface of the mercury *b'*, and by providing the slip-joint *f'* said pipe end *f²* may be adjusted to and from the surface of the mercury, as desired. The bottom *b²* of pipe *b* is provided, preferably, with a side opening *b³*, a horizontal laterally-projecting plate *b⁴*, having at one edge an upwardly-projecting plate *b⁵*. The plate *b⁴* normally rests upon the top of the mercury *b'*, with its outer edge approximating the inner wall of the receiver B, as shown more plainly in Fig. 2. The supply escaping from the exit-opening *b³* of pipe *b* falls upon plate *b⁴*, and the vertical plate *b⁵* prevents such supply passing off of plate *b⁴*

in a direction the reverse of that of the rotation of the receiver, said supply being passed into the receiver on the side opposite to that in which the pump-pipe *f* is located. The pump *E* is of a kind which admits of the passage through it of a large bulk or volume of material, the same being a valveless or centrifugal pump and is commercially termed a "coal-pump." The discharge end *f*² of the pump preferably empties into a subsequent grate-box *A'*, which preferably connects with an amalgamating apparatus of any suitable construction.

In the receiver shown in Fig. 2 between the supply-pipe *b* and the suction-pipe *f* and connected to said pipes is a curved or other suitably-formed bar *G*, having radially-arranged rakes or fingers *g* for distributing the gangue over the surface of the mercury as the receiver rotates.

In Fig. 6 I have shown the receiver provided with a hollow nipple or step-bearing *h* on its under side, which bearing also serves as the wheel or pulley *d* for the band or belt *d'*, the spindle *C* entering such nipple and having an elastic box-bearing *c'* therein, as well as the step-bearing *c*². The spindle *C* is screw-threaded into a bracket *H*, provided with a set-screw *h'* for holding it and the receiver *B* in their adjusted positions, the receiver in this case being vertically adjusted to and from the ends of pipes *b f* instead of adjusting the pipe *f*, as hereinbefore described, and the receiver *B* only is gyrated instead of it and its spindle, as shown in Fig. 1.

In Fig. 7 a modification is shown wherein the spindle *C*, bracket *D*, and elastic box *c'*, as shown in Fig. 1, is used. In this case, however, the spindle *C* is connected to the receiver by a spline and has a set-screw attachment for adjusting the receiver vertically, and the gyrating-rod attachment *e* is swiveled to the receiver. In all cases where the receiver is vertically adjustable the lower end *b*² of pipe *b* is also adjustable, so as to keep its horizontal plate *b*⁴ upon the surface of the mercury *b'*, and to this end the lower portion *b*² of pipe *b* is made separate from the latter and preferably of a larger diameter, and is screw-threaded in a bracket *l*, secured within the receiver, as shown more plainly in Fig. 7. If desired, an arresting-plate *l'* may be located within the pipe end *b*². (See Fig. 7.)

The operation is as follows: The supply of gangue with water falling upon the grate *a* is deprived of any bowlders or bulky matter contained therein, while the screenings are conducted through pipe *b* to the receiver *B*. Such gangue as it emerges from the pipe-opening *b*³ falls upon the plate *b*⁴ and not into the mercury, and all splashing and flouing of the mercury is avoided. The traveling motion imparted to the gangue as it passes through the pipe *b* ceases or is arrested when the gangue falls upon the plate *b*⁴. As the vertical plate *b*³ prevents such gangue passing off of the

plate *b*⁴ in a direction contrary to that of the rotation of the receiver *B*, the gyratory movement of the latter, effected by the rod *e*, moves the gangue off of the plate *b*⁴ in the direction of the rotation of the receiver onto the top of the mercury. As the receiver rotates, the gangue comes in contact with the rakes *g*, which distribute the gangue over the surface of the mercury as it travels from pipe *b* to pipe *f*. During this movement the agitation of the gangue, produced by the rakes *g* and the gyratory movement of the receiver, separates the ore from the gangue. When the latter comes within the influence of the suction in pipe *f*, produced by the pump *E*, such gangue is raised and discharged by the pump onto the grate or sluice-box *A'*. All these operations of supplying or feeding the gangue into the receiver, arresting or stopping the traveling motion of the gangue, distributing it in the receiver and discharging it therefrom on the top of the mercury are effected without agitating the mercury to flour it, and hence there is no loss of mercury, and the separation is more thoroughly and rapidly accomplished.

As it is obvious that the novel features of my invention may be greatly varied to accomplish the foregoing described results without departing from the spirit of the same, I do not confine myself to the constructions and arrangements of parts shown and described.

What I claim is—

1. The method of extracting metals from ore, which consists in placing a layer of mercury in a vessel, rotating the vessel, depositing the ore upon the surface of the mercury at one side of the vessel, thereby causing the metal to be taken up by the mercury and the gangue floating upon the mercury to be carried to a point remote from the point of deposit, and removing the gangue by a vacuum.

2. The method of extracting metals from ore, which consists in placing a layer of mercury in a vessel, rotating and oscillating the vessel, depositing the ore upon the surface of the mercury at one side of the vessel, thereby causing the metal to be taken up by the mercury and the gangue floating upon the mercury to be carried to a point remote from the point of deposit, and removing the gangue.

3. The combination of a vessel revolvably supported on a central shaft, an ore-supply pipe having its outlet within and at one side of the vessel, said outlet provided with wings for preventing the ore from falling to the bottom of the vessel or moving circumferentially in one direction, a depending discharge-pipe arranged within the vessel at a point remote from the supply-pipe, means for removing the gangue through the discharge-pipe, and means for rotating the vessel, as set forth.

4. The combination of a vessel revolvably supported on a central shaft, an ore-supply pipe having its outlet within and at one side of the vessel, said outlet provided with wings for preventing the ore from falling to the

bottom of the vessel or moving circumferentially in one direction, a depending discharge-pipe arranged within the vessel at a point remote from the supply-pipe, means for removing the gangue through the discharge-pipe, and means for rotating and oscillating the vessel, as set forth.

5 5. The combination of a vessel revolubly supported on a central shaft, an ore-supply pipe having its outlet within and at one side of the vessel, said outlet provided with wings for preventing the ore from falling to the bottom of the vessel or moving circumferentially in one direction, a depending discharge-
 10 pipe arranged within the vessel at a point remote from the supply-pipe, distributors arranged between the supply and discharge pipes, means for removing the gangue through the discharge-pipe, and means for rotating the
 15 vessel, as set forth.
 20

6. The combination of a vessel revolubly supported on a central shaft, an ore-supply pipe having its outlet within and at one side of the vessel, said outlet provided with wings
 25 for preventing the ore from falling to the bottom of the vessel or moving circumferentially in one direction, a depending discharge-

pipe arranged within the vessel at a point remote from the supply-pipe, means for creating a vacuum in said pipe for removing the gangue, and means for rotating the vessel, as set forth. 30

7. The combination of a vessel revolubly supported upon a central shaft, an ore-supply pipe within the vessel, a depending discharge-
 35 pipe arranged within the vessel at a point remote from the supply-pipe, means for removing the gangue through the discharge-pipe, and means for rotating said vessel, substantially as set forth. 40

8. The combination of a vessel revolubly supported upon a central shaft, an ore-supply pipe within the vessel, a depending discharge-pipe arranged within the vessel at a point remote from the supply-pipe, and means for
 45 rotating and oscillating said vessel, substantially as set forth.

In testimony whereof I affix my signature in presence of two witnesses.

CHARLES F. PIKE.

Witnesses:

GEO. R. BYINGTON,
 S. J. VAN STAVOREN.